

VOLTAGE 2.0 to 56 Volts

POWER 500 mWatts

DO-35

Unit: inch (mm)

FEATURES

- Planar Die construction
- 500mW Power Dissipation
- Ideally Suited for Automated Assembly Processes

MECHANICAL DATA

- Case: Molded Glass DO-35
- Terminals: Solderable per MIL-STD-202, Method 208
- Polarity: See Diagram Below
- Approx. Weight: 0.13 grams
- Mounting Position: Any
- Ordering information
 - Suffix : " -35 " to order DO-35 Package
- Packing information
 - B - 2K per Bulk box
 - T/R - 10K per 13" plastic Reel
 - T/B - 5K per horiz. tape & Ammo box

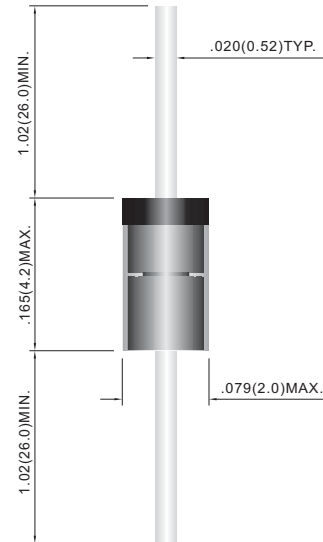

MAXIMUM RATINGS AND ELECTRICAL CHARACTERISTICS

Parameter	Symbol	Value	Units
Power Dissipation at Tamb = 25 °C	P _{TOT}	500	mW
Junction Temperature	T _J	175	°C
Storage Temperature Range	T _s	-65 to +175	°C

Valid provided that leads at a distance of 10mm from case are kept at ambient temperature.

Parameter	Symbol	Min.	Typ.	Max.	Units
Thermal Resistance Junction to Ambient Air	R _{thA}	--	--	0.3	K/mW
Forward Voltage at I _F = 100mA	V _F	--	--	1	V

Valid provided that leads at a distance of 10mm from case are kept at ambient temperature.

Part Number	CLASS	V _z @ I _{ZT}		I _Z (mA)	V _R (V)	I _R (μ A) MAX	I _{zt} (mA)	Z _{ZT} (Ω) MAX	I _{zk} (mA)	Z _{ZK} (Ω) MAX	Marking code
		Min. V	Max. V								
GDZ 2.0	A	1.88	2.10	20	0.5	120	20	140	1	2000	2A0
	B	2.02	2.20								2B0
GDZ 2.2	A	2.12	2.30	20	0.7	120	20	120	1	2000	2A2
	B	2.22	2.41								2B2
GDZ 2.4	A	2.33	2.52	20	1.0	120	20	100	1	2000	2A4
	B	2.43	2.63								2B4
GDZ 2.7	A	2.54	2.75	20	1.0	120	20	100	1	1000	2A7
	B	2.69	2.91								2B7
GDZ 3.0	A	2.85	3.07	20	1.0	50	20	80	1	1000	3A0
	B	3.01	3.22								3B0
GDZ 3.3	A	3.16	3.38	20	1.0	20	20	70	1	1000	3A3
	B	3.32	3.53								3B3
GDZ 3.6	A	3.455	3.695	20	1.0	10	20	60	1	1000	3A6
	B	3.60	3.845								3B6
GDZ 3.9	A	3.74	4.01	20	1.0	5	20	50	1	1000	3A9
	B	3.89	4.16								3B9
GDZ 4.3	A	4.04	4.29	20	1.0	5	20	40	1	1000	4A3
	B	4.17	4.43								4B3
	C	4.30	4.57								4C3
GDZ 4.7	A	4.44	4.68	20	1.0	5	20	25	1	900	4A7
	B	4.55	4.80								4B7
	C	4.68	4.93								4C7
GDZ 5.1	A	4.81	5.07	20	1.5	5	20	20	1	800	5A1
	B	4.94	5.20								5B1
	C	5.09	5.37								5C1
GDZ 5.6	A	5.28	5.55	20	2.5	5	20	13	1	500	5A6
	B	5.45	5.73								5B6
	C	5.61	5.91								5C6
GDZ 6.2	A	5.78	6.09	20	3.0	5	20	10	1	300	6A2
	B	5.96	6.27								6B2
	C	6.12	6.44								6C2
GDZ 6.8	A	6.29	6.63	20	3.5	2	20	8	0.5	150	6A8
	B	6.49	6.83								6B8
	C	6.66	7.01								6C8
GDZ 7.5	A	6.85	7.22	20	4.0	0.5	20	8	0.5	120	7A5
	B	7.07	7.45								7B5
	C	7.29	7.67								7C5
GDZ 8.2	A	7.53	7.92	20	5.0	0.5	20	8	0.5	120	8A2
	B	7.78	8.19								8B2
	C	8.03	8.45								8C2
GDZ 9.1	A	8.29	8.73	20	6.0	0.5	20	8	0.5	120	9A1
	B	8.57	9.01								9B1
	C	8.83	9.30								9C1
GDZ 10	A	9.12	9.59	20	7.0	0.2	20	8	0.5	120	10A
	B	9.41	9.90								10B
	C	9.70	10.20								10C
	D	9.94	10.44								11D
GDZ 11	A	10.18	10.71	10	8.0	0.2	10	10	0.5	120	11A
	B	10.50	11.05								11B
	C	10.82	11.38								11C

Part Number	CLASS	Vz @ Izt		IZ (mA)	VR (V)	IR(μA) MAX	Izt (mA)	ZzT(Ω) MAX	Izk (mA)	Zzk(Ω) MAX	Marking Code
		Min. V	Max. V								
GDZ 12	A	11.13	11.71	10	9.0	0.2	10	12	0.5	110	12A
	B	11.44	12.03								12B
	C	11.74	12.35								12C
GDZ 13	A	12.11	12.75	10	10	0.2	10	14	0.5	110	13A
	B	12.55	13.21								13B
	C	12.99	13.66								13C
GDZ 15	A	13.44	14.13	10	11	0.2	10	16	0.5	110	15A
	B	13.89	14.62								15B
	C	14.35	15.09								15C
GDZ 16	A	14.80	15.57	10	12	0.2	10	18	0.5	150	16A
	B	15.25	16.04								16B
	C	15.69	16.51								16C
GDZ 18	A	16.22	17.06	10	13	0.2	10	23	0.5	150	18A
	B	16.82	17.70								18B
	C	17.42	18.33								18C
GDZ 20	A	18.02	18.96	10	15	0.2	10	28	0.5	200	20A
	B	18.63	19.59								20B
	C	19.23	20.22								20C
	D	19.72	20.72								20D
GDZ 22	A	20.15	21.20	5	17	0.2	5	30	0.5	200	22A
	B	20.64	21.71								22B
	C	21.08	22.17								22C
	D	21.52	22.63								22D
GDZ 24	A	22.05	23.18	5	19	0.2	5	35	0.5	200	24A
	B	22.61	23.77								24B
	C	23.12	24.31								24C
	D	23.63	24.85								24D
GDZ 27	A	24.26	25.52	5	21	0.2	5	45	0.5	250	27A
	B	24.97	26.26								27B
	C	25.63	26.95								27C
	D	26.29	27.64								27D
GDZ 30	A	26.99	28.39	5	23	0.2	5	55	0.5	250	30A
	B	27.70	29.13								30B
	C	28.36	29.82								30C
	D	29.02	30.51								30D
GDZ 33	A	29.68	31.22	5	25	0.2	5	65	0.5	250	33A
	B	30.32	31.88								33B
	C	30.90	32.50								33C
	D	31.49	33.11								33D
GDZ 36	A	32.14	33.79	5	27	0.2	5	75	0.5	250	36A
	B	32.79	34.49								36B
	C	33.40	35.13								36C
	D	34.01	35.77								36D
GDZ 39	A	34.68	36.47	5	30	0.2	5	85	0.5	250	39A
	B	35.36	37.19								39B
	C	36.00	37.85								39C
	D	36.63	38.52								39D
GDZ 41		37.00	41.00	5	30	0.2	5	90	-	-	41
GDZ 43		40.00	45.00	5	33	0.2	5	90	--		43
GDZ 47		44.00	49.00	5	36	0.2	5	90	--		47
GDZ 51		48.00	54.00	5	39	0.2	5	110	--		51
GDZ 56		53.00	60.00	5	43	0.2	5	110	--		56

RATING AND CHARACTERISTIC CURVES

