

Features

- 402-405 MHz (10 MICS channels) and 433-434 MHz (2 ISM channels)
- High data rate (800/400/200 kbps raw data rate)
- High performance MAC with automatic error handling and flow control, typ 1.5×10^{-10} BER.
- Very few external components (3 pcs + antenna matching)
- Extremely low power consumption (5 mA, continuous TX / RX, 1 mA low power mode)
- Ultra low power wakeup circuit (250 nA)
- Standards compatible (MICS, FCC, IEC)

Applications

- Implantable Devices e.g., Pacemakers, ICD's, Neurostimulators, Implantable Insulin Pumps, Bladder Control Devices, implantable physiological monitors
- Body area network, short range device applications using the 433 MHz ISM band.

Ordering Information

ZL70101LDG1A	48 pin QFN*, for base stations** (trays, bake and drypack)
ZL70101UBJ	die, implantable grade (trays and drypack)
ZL70101LDG1 -	48 pin QFN*, for evaluation only** (not available in volume)

* Pb Free Matte Tin ** Not for implantable use

Description

The ZL70101 is a high performance half duplex RF communications link for medical implantable applications.

The system is very flexible and supports several low power wakeup options. Extremely low power is achievable using the 2.45 GHz ISM Band Wakeup-receiver option. The high level of integration includes a Media Access Controller, providing complete control of the device along with coding and decoding of RF messages. A standard SPI interface provides for easy access by the application.

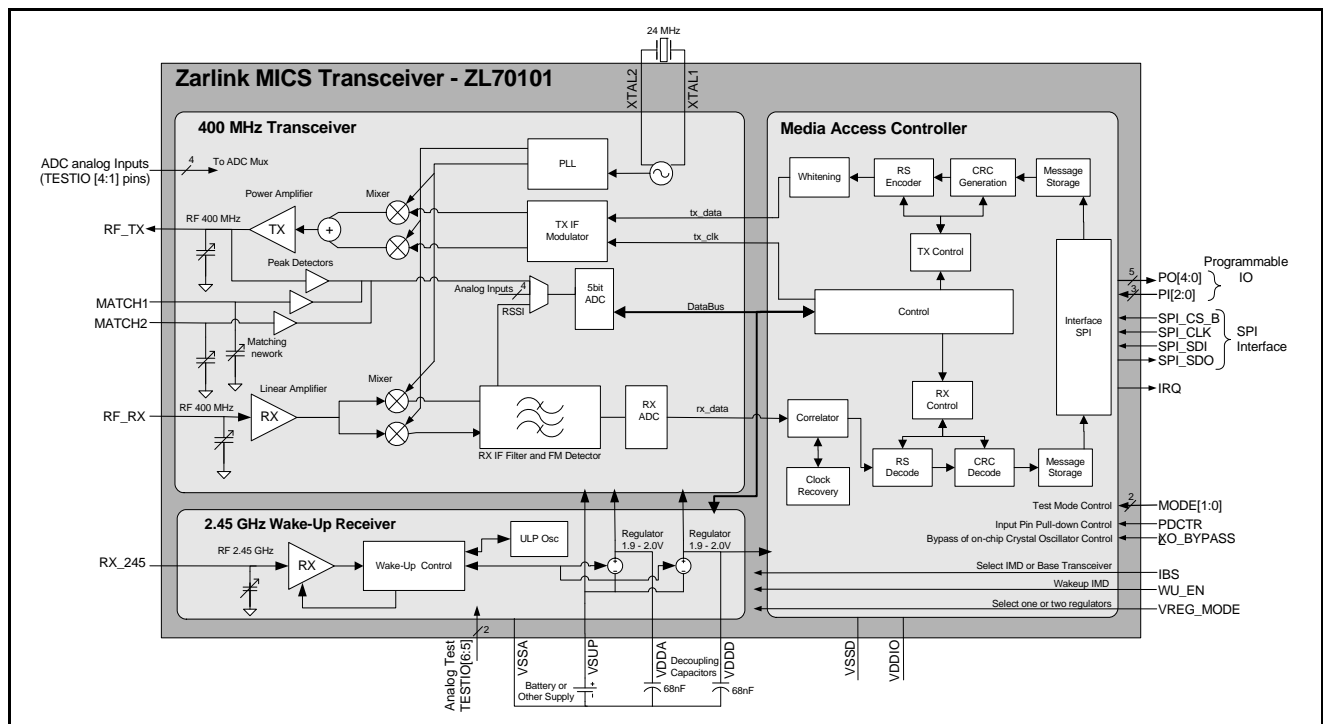

Figure 1 - ZL70101 Block Diagram

1.0 ZL70101 Functional Description

1.1 General

The ZL70101 is an ultra low power, high bandwidth RF link for medical implantable applications. It operates in the MICS (Medical Implant Communication Service) at 402-405 MHz. It uses a Reed-Solomon coding scheme together with CRC error detection to achieve an extremely reliable link. For data-blocks, a maximum BER (Bit Error Rate) of less than 1.5×10^{-10} is provided assuming a raw radio channel quality of 10^{-3} BER. An even higher quality of 2×10^{-14} BER is available using housekeeping messages, a facility fully described in the ZL70101 Design Manual.

1.2 Basic Operation and Modes

The ZL70101 transceiver is intended for operation in both an implant and base station. These systems have different requirements especially with regard to power consumption. Therefore, the ZL70101 transceiver has defined two fundamental startup modes of operation:

- Implantable Medical Device (IMD) Mode
- Base Mode

When configured as an IMD, the transceiver is usually asleep and in a very low current state. The IMD may be woken up to initiate communications by using a 2.45 GHz link or directly by the IMD processor via the WU_EN pin. This flexibility leads to the following options for waking up an IMD transceiver for communication.

- IMD transceiver woken up by specially coded 2.45 GHz wakeup message using an ultra low power sniffing method.
- IMD transceiver woken up to sniff 400 MHz link. The ZL70101 supports such a mode of operation although the 2.45 GHz wakeup system has lower power consumption.
- IMD transceiver woken to send an emergency message in which case no clear channel assessment by the Basestation is required.
- IMD transceiver woken up by a low frequency inductive link (as typically used in pacemakers/ICDs) or some alternative mechanism.

2.0 Example Configurations

The ZL70101 Transceiver device is configurable as an implant transceiver or as a base station transceiver. Typical configurations are shown in the following diagrams. Two different configurations for implants are shown, the first is optimized for few external components and the second is optimized for highest performance.

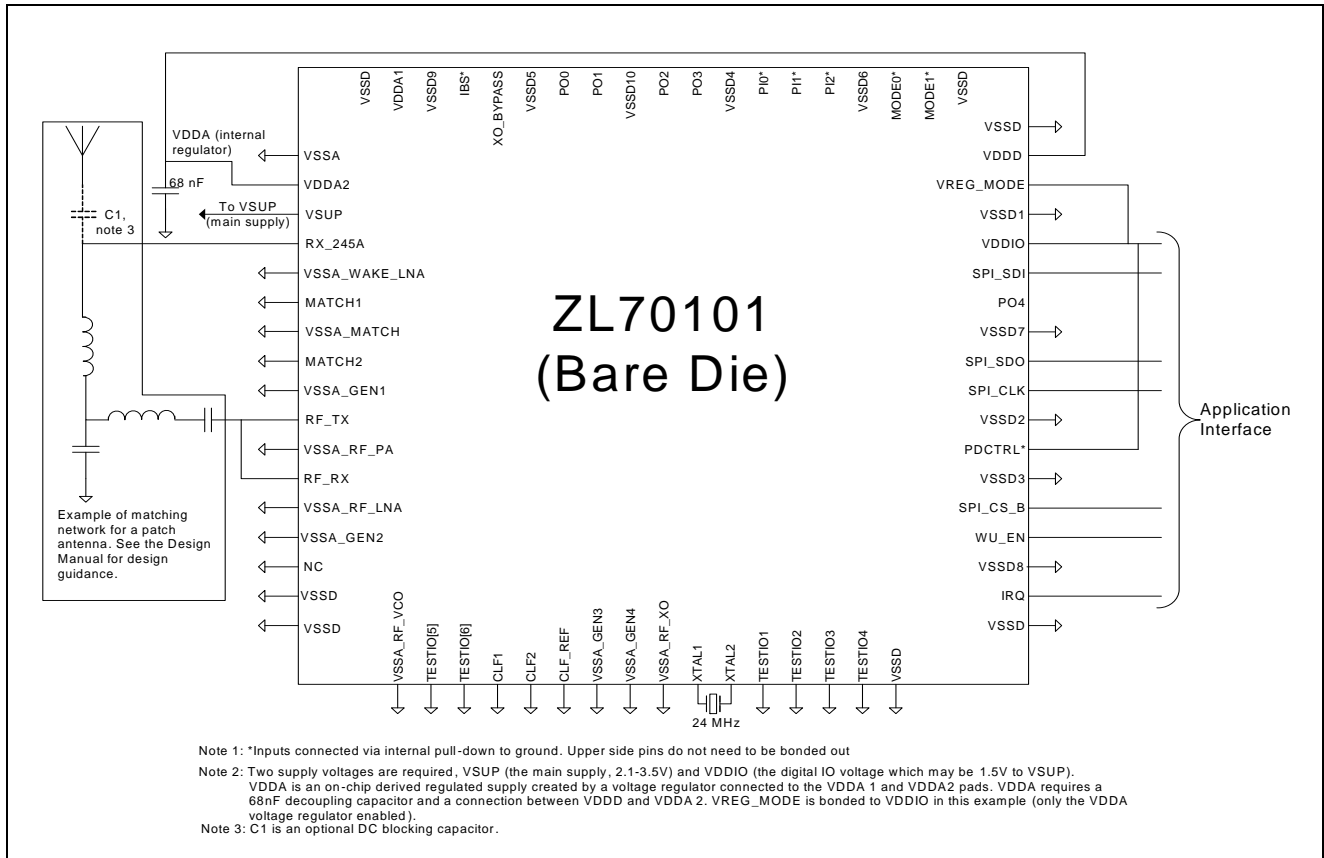

Figure 2 - ZL70101 Transceiver Configured for an Implant - Minimum External Components

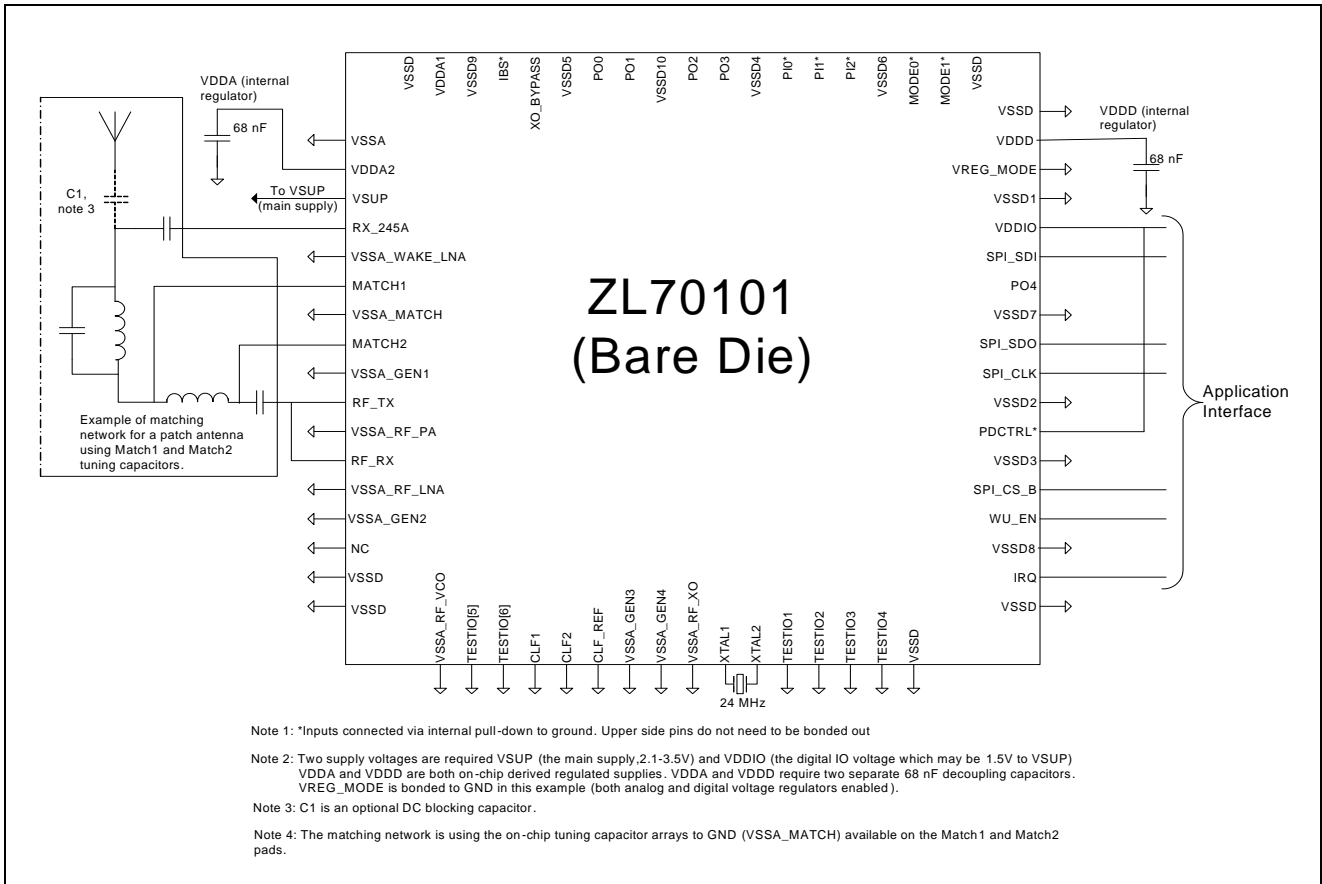

Figure 3 - ZL70101 Transceiver Configured for an Implant - Optimal Performance

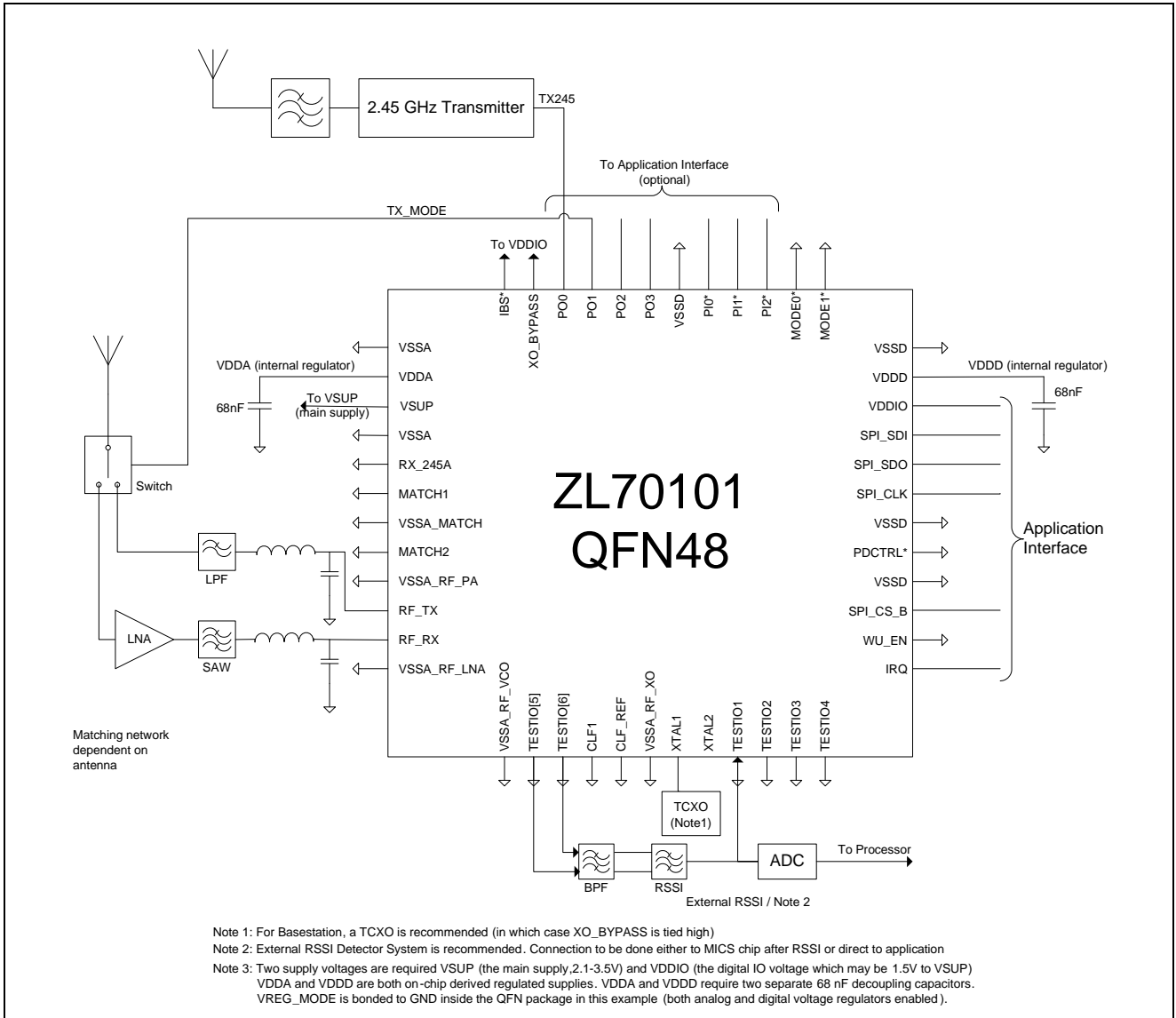

Figure 4 - ZL70101 Transceiver Configured for a Base Station

3.0 Mechanical Characteristics

3.1 48 pin QFN Package

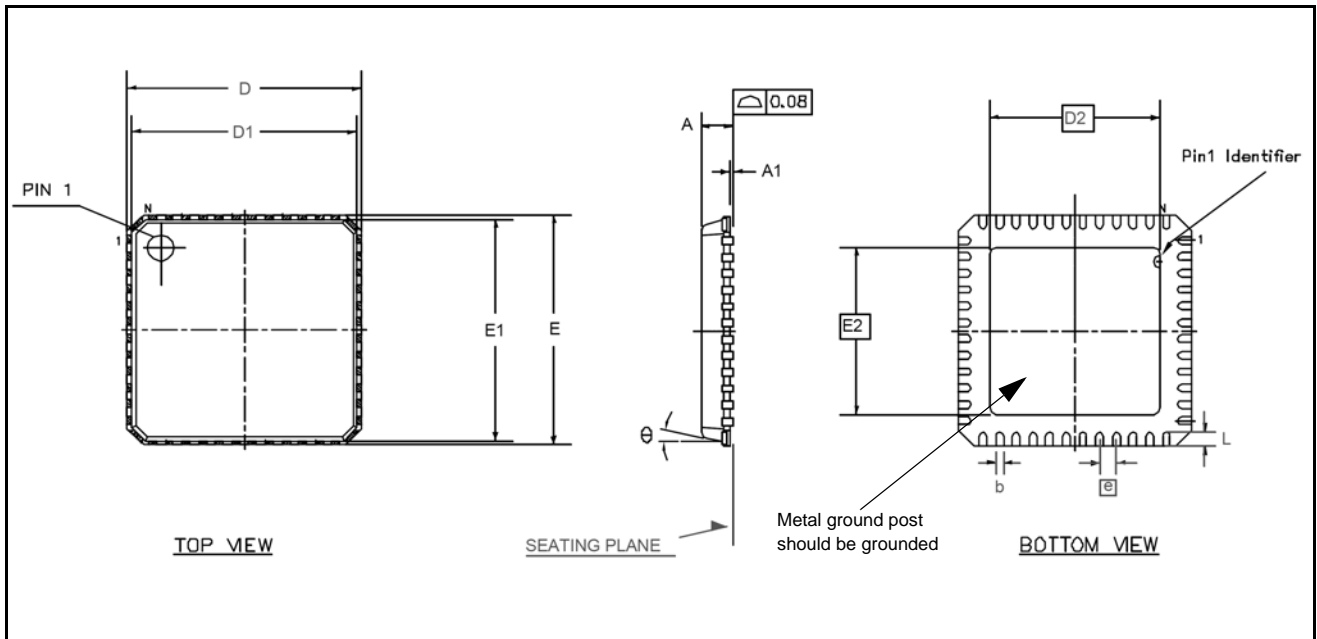

Figure 5 - 48 pin QFN Dimensions

SYMBOL	COMMON DIMENSIONS		
	MIN.	NOM.	MAX.
A	0.800	0.850	0.900
A1	0.005	0.025	0.045
b	0.180	0.230	0.300
D	6.900	7.000	7.100
D1	6.650	6.750	6.850
D2	5.10 BSC		
E	6.900	7.000	7.100
E1	6.650	6.750	6.850
E2	5.10 BSC		
N	48		
Nd	12		
Ne	12		
\square	0.50 BSC		
L	0.300	0.400	0.500
θ	10°	11°	12°

- NOTES:
1. DIMENSIONING & TOLERANCES CONFORM TO ASME Y14.5M. - 1994.
 2. N IS THE NUMBER OF TERMINALS.
Nd & Ne ARE THE NUMBER OF TERMINALS IN X & Y DIRECTION RESPECTIVELY.
 3. ALL DIMENSIONS ARE IN MILLIMETERS.
 4. LEAD COUNT IS 48
 5. PACKAGE WARPAGE MAX 0.08mm.
 6. NOT TO SCALE.

Conforms to JEDEC MO-220

4.0 Electrical Characteristics

Absolute Maximum ratings - Voltages are with respect to ground (VSS) unless otherwise stated.

	Parameter	Symbol	Min.	Max.	Unit	Notes
1	Supply voltage	VSUP	0	3.6	V	
2	Input voltage (Digital IO)	VDDIO	0	VSUP	V _{peak} rel. to VSS	
3	Unpowered Storage temperature	T _{stg}	-40	+125	°C	

Recommended Operating Conditions - Note1

	Parameter	Symbol	Min.	Typ.	Max.	Unit	Notes
4	Supply voltage	VSUP	2.1		3.5	V	
5	Input voltage (Digital IO)	VDDIO	1.5		VSUP	V	Note 2
6	Operating temperature	T _{op}	0		55	°C	

Note 1: This table lists the external conditions under which the chip shall operate according to the specifications.

Note 2: Note that VDDIO must never be higher than VSUP even during system startup.

5.0 Additional Information

5.1 Quality

Zarlink's QA procedures are based on MIL-PRF-38535 and MIL-STD 833.

ZL70101 can be delivered either as dies (ZL70101UBJ) or in a QFN package (ZL70101LDG1A), see ordering information on Page 1 for further details. The dies are suitable for implantable application but can also be used for non-implantable applications and base station applications. The QFN devices are only for non-implantable applications and base station applications.

The same chip is used for bare die and in the QFN packaged device. The QFN package and the assembly process are not qualified for implantable applications. The QFN devices can therefore not be used in implantable applications.

5.2 Technical Documentation

A Full Data sheet and a Design Manual are available for ZL70101. Please contact Zarlink for more information.



**For more information about all Zarlink products
visit our Web Site at
www.zarlink.com**

Information relating to products and services furnished herein by Zarlink Semiconductor Inc. or its subsidiaries (collectively "Zarlink") is believed to be reliable. However, Zarlink assumes no liability for errors that may appear in this publication, or for liability otherwise arising from the application or use of any such information, product or service or for any infringement of patents or other intellectual property rights owned by third parties which may result from such application or use. Neither the supply of such information or purchase of product or service conveys any license, either express or implied, under patents or other intellectual property rights owned by Zarlink or licensed from third parties by Zarlink, whatsoever. Purchasers of products are also hereby notified that the use of product in certain ways or in combination with Zarlink, or non-Zarlink furnished goods or services may infringe patents or other intellectual property rights owned by Zarlink.

This publication is issued to provide information only and (unless agreed by Zarlink in writing) may not be used, applied or reproduced for any purpose nor form part of any order or contract nor to be regarded as a representation relating to the products or services concerned. The products, their specifications, services and other information appearing in this publication are subject to change by Zarlink without notice. No warranty or guarantee express or implied is made regarding the capability, performance or suitability of any product or service. Information concerning possible methods of use is provided as a guide only and does not constitute any guarantee that such methods of use will be satisfactory in a specific piece of equipment. It is the user's responsibility to fully determine the performance and suitability of any equipment using such information and to ensure that any publication or data used is up to date and has not been superseded. Manufacturing does not necessarily include testing of all functions or parameters. These products are not suitable for use in any medical products whose failure to perform may result in significant injury or death to the user. All products and materials are sold and services provided subject to Zarlink's conditions of sale which are available on request.

Purchase of Zarlink's I2C components conveys a license under the Philips I2C Patent rights to use these components in an I2C System, provided that the system conforms to the I2C Standard Specification as defined by Philips.

Zarlink, ZL, the Zarlink Semiconductor logo and the Legerity logo and combinations thereof, VoiceEdge, VoicePort, SLAC, ISLIC, ISLAC and VoicePath are trademarks of Zarlink Semiconductor Inc.

TECHNICAL DOCUMENTATION - NOT FOR RESALE
