



**AS8413**

**HIGH PERFORMANCE  
AUTOMOTIVE SONAR INTRUSION**

**Data Sheet  
March 2001**

## Key Features

- True sonar/pulse-echo operation
- Master/slave synchronization
- Wide dynamic range
- Programmable sensitivity levels
- Self-adaptive to vehicle interiors
- Self-adaptive to temperature and environmental changes
- High sensitivity to intrusion
- Immunity to false alarms
- Detection of sabotage attempts
- Compatible with standard 40 kHz ultrasonic transducers
- Specific for systems with multiple transducers
- No adjustments needed at factory or at field
- Few external components
- Time reference: external clock or oscillator based on crystal/ceramic resonator
- Built-in self-test
- Internal power-on-reset
- Advanced CMOS technology
- Low power consumption: 0.65 to 1.0 mA
- Operation between -40°C and +85 °C
- Available in 24-pin DIP and 24-pin SOIC package

## General Description

The AS8413 is a signal processing IC designed to implement reliable, high-performance sonar intrusion detectors. It generates short 40 kHz bursts to feed an ultrasonic transducer. The resulting sonar waves are reflected on the vehicle interior and the echoes are received by another transducer. Inside the AS8413, the electrical signal is first submitted to an analog conditioning circuit, then it is digitized and processed by a DSP, whose output is analyzed by a discriminator based on fuzzy-logic techniques. Thus, true intrusion conditions can be discerned from natural phenomena and other allowable disturbances.

Synchronization between the sonar waves from 2 or more pairs of transducers is made possible by means of a master/slave configuration. Each pair is controlled by a AS8413 IC.

No adjustments are necessary at factory or at the field, as the AS8413 is self-adaptive to the physical and environmental conditions. Compact and EMI-resistant intrusion detectors are made possible, due to the small number of components.

## Block Diagram

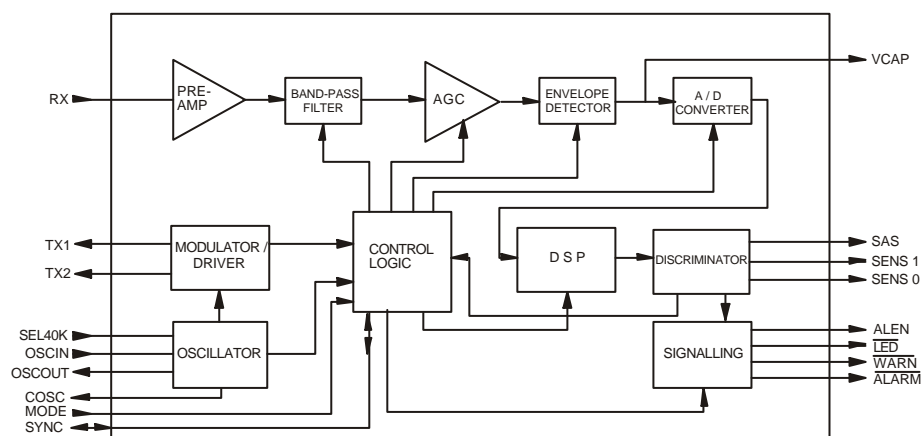

## Pin Description

AS8413		
Pin #	Name	Description
1	TX1	40-kHz burst generator - output 1.
2	OSCIN	Clock input or crystal / ceramic resonator connection.
3	OSCOU	Crystal / ceramic resonator connection. Not connected when external clock is applied.
4	COSC	Clock output to slave IC
5	VCAP	Pin for programming capacitor at the envelope detector.
6	AVDD	Analog supply voltage (+5V).
7	AGND	Analog ground.
8	RXGND	Analog ground.
9	RX	Ultrasonic echo input.
10	SEL40K	Time reference select input (SEL40K='1' to select 40 kHz or SEL 40K='0' to select 400 kHz at OSCIN).
11	ALEN	Alarm enable input (when ALEN = '0', the outputs $\overline{\text{ALARM}}$ , $\overline{\text{WARN}}$ and $\overline{\text{LED}}$ are disabled).
12	MODE	Master/slave configuration pin (MODE='0' to configure slave IC, MODE='1' To configure master IC with delayed sync and MODE open, to configure master IC without delayed sync)
13	SENS0	Sensitivity selection (least significant bit).
14	SENS1	Sensitivity selection (most significant bit).
15	SAS	SAS enable input (SAS='1' activates Self-Adjusting Sensitivity, SAS='0' keeps sensitivity fixed)
16	N.C.	(not connected)
17	$\overline{\text{TP}}$	Test / reset pin. A rising edge resets the IC. This pin should be left unconnected or tied to VDD for normal operation.
18	VDD	Digital supply voltage (+5V).
19	GND	Digital ground
20	SYNC	Synchronization pin. This pin is configured as output if pin MODE='1' and as input if MODE='0'.
21	$\overline{\text{LED}}$	Active-low signalling LED output (open drain).
22	$\overline{\text{WARN}}$	Active-low auxiliary alarm output (open drain).
23	$\overline{\text{ALARM}}$	Active-low main alarm output (open drain).
24	TX2	40-kHz burst generator - output 2.

## Pinout & Packaging

Change pinout according to Pin Description.

### Available Package(s):

- 24 pin SOIC
- (24 pin Skinny DIP)

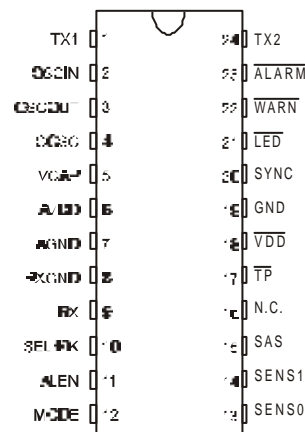

## Absolute Maximum Ratings

- Conditions:
1. All voltages referenced to GND
  2. AVDD connected to VDD
  3. AGND connected to GND

Supply Voltage	< 7V
Input Pin Voltage	-0,3 V to VDD + 0.3 V
Output Pin Voltage	-0,3 V to VDD + 0.3 V
Power dissipation	500 mW
Operating temperature under bias	-40 °C to +85 °C
Storage Temperature	-65 °C to +150 °C
Latch-up immunity	-10mA ... + 10mA

Note: Stresses above these values may cause permanent damage to the device.  
Functional operational at these values is not implied  
ESD immunity / HBM; 1500 Ohm; 100 pF

## Recommended Operating Conditions

Parameter	Symbol	Min	Typ	Max	Units
Supply Voltage (VDD, AVDD)	V <sub>DD</sub>	4.5	5.0	5.5	V
Operating Temperature Range	T <sub>O</sub>	-40	-	85	°C
Clock Frequency (SEL40K=1)	F <sub>CK</sub>	39	40	41	kHz
AC Peak Voltage at RX Input	V <sub>IN</sub>	0.1	-	10	mV

## D.C. Electrical Characteristics

(V<sub>DD</sub> = 5 V, V<sub>SS</sub> = Ground, T<sub>A</sub> = -40 °C to +85 °C)

Parameter	Symbol	Min	Typ	Max	Units	Conditions
Low Level Input Voltage	V <sub>il</sub>	-	-	1.5	V	Pins 2, 10, 13, 14, 15, 20
High Level Input Voltage	V <sub>ih</sub>	3.5	-	-	V	Pins 2, 10, 13, 14, 15, 20
Low Level Input Voltage	V <sub>il</sub>	-	-	0.5	V	Pin 12
High Level Input Voltage	V <sub>ih</sub>	4.5	-	-	V	Pin 12
Low-to-High Threshold	V <sub>t+</sub>	-	3.0	3.5	V	Pin 11 (Schmitt Trigger Input)
High-to-Low Threshold	V <sub>t-</sub>	1.4	1.8	-	V	Pin 11 (Schmitt Trigger Input)
Hysteresis	V <sub>h</sub>	0.6	-	-	V	Pin 11
Low Level Input Current	I <sub>il</sub>	-1	-	-	µA	Pins 10, 11, 13, 14, 15 (V <sub>DD</sub> =5 V)
High Level Input Current	I <sub>ih</sub>	-	-	1	µA	Pins 10,11, 13, 14, 15 (V <sub>DD</sub> =5V)
Input Resistance	R <sub>in</sub>	-	200	-	kΩ	Pin 9

Low Level Output Voltage	Vol	-		0.5	V	Pins 1, 20, 24	I <sub>ol</sub> =3 mA
		-		0.5	V	Pins 22,23	I <sub>ol</sub> =4 mA
		-		0.5	V	Pins 21	I <sub>ol</sub> =12mA
High Level Output Voltage	Voh	4.0	-	-	V	Pins 1, 20, 24	I <sub>oh</sub> =-3 mA
Low Level Output Voltage	V <sub>ol</sub>	-	-	0.4	V	Pin 4 (SEL40K= 0)	I <sub>ol</sub> =100uA
		-	-	1.5	V	Pin 4 (SEL40K= 1)	I <sub>ol</sub> =10 uA
High Level Output Voltage	V <sub>oh</sub>	4.6	-	-	V	Pin 4 (SEL40K= 0)	I <sub>oh</sub> =-100 uA
		3.5	-	-	V	Pin 4 (SEL40K= 1)	I <sub>oh</sub> =-10 uA
High-Z Output Current	I <sub>oz</sub>	-	-	10	µA	Pins 21, 22, 23	V <sub>o</sub> =5V
Total Supply Current	I <sub>dd</sub>	-	0.65	1.0	mA	SEL40K= 1	crystal or clock
		-	1.0	1.6	mA	SEL40K= 0	ceramic resonator C1=C2=100pF

### A.C. Electrical Characteristics

(V<sub>DD</sub> = 5 V, V<sub>SS</sub> = Ground, T<sub>A</sub> = 25°C)

Parameter	Symbol	Min	Typ	Max	Units	Conditions
Power-on-reset width	t <sub>por</sub>	50	-	70	ms	SEL40K= 0, resonator / clock
		500	-	530		SEL40K= 1, clock
		500	-	800		SEL40K= 1, crystal
Self-test delay (incl. t <sub>por</sub> )	t <sub>std</sub>	1.3	-	1.4	s	SEL40K= 0, resonator / clock
		1.7	-	1.9		SEL40K= 1, clock
		1.7	-	2.1		SEL40K= 1, crystal
Fault indication pulse width	t <sub>stw</sub>	4.3	-	4.6	s	
SYNC pulse width	t <sub>sync</sub>	-	0.6	-	ms	
SYNC period	T <sub>sync</sub>	-	44.4	-	ms	
ALARM low pulse width	t <sub>al</sub>	200	-	-	ms	Pins 22, 23
LED low pulse width	t <sub>onn</sub>	-	89	-	ms	narrow = no detection
	t <sub>onw</sub>	-	977	-	ms	wide = detection
LED low pulse width	t <sub>off</sub>	-	888	-	ms	

### System Description

Ultrasonic intrusion detectors are very popular in vehicle security systems, due to their low cost, good area coverage and easiness of installation. The AS8413 uses the sonar principle to build a high-performance intrusion detector that follows the requirements of the OEM automotive industry. Additionally, the IC supports the use of two or more pairs of sensors. As very short ultrasonic bursts are sent, the power needed to drive the transmitter is reduced. Interference and signal cancellation effects, present in systems with continuous transmission, are virtually eliminated.

Fig. 1 shows the pulse/echo timing generated by the AS8413. The basic concept behind the AS8413 is the detection of changes in the relative position of objects in side the vehicle, by monitoring successive echo patterns with a discriminator based on fuzzy-logic. Despite the higher complexity of this approach, that demands both analog and digital signal processing, the solution is made cost-effective with the use of a single IC and a small number of external components

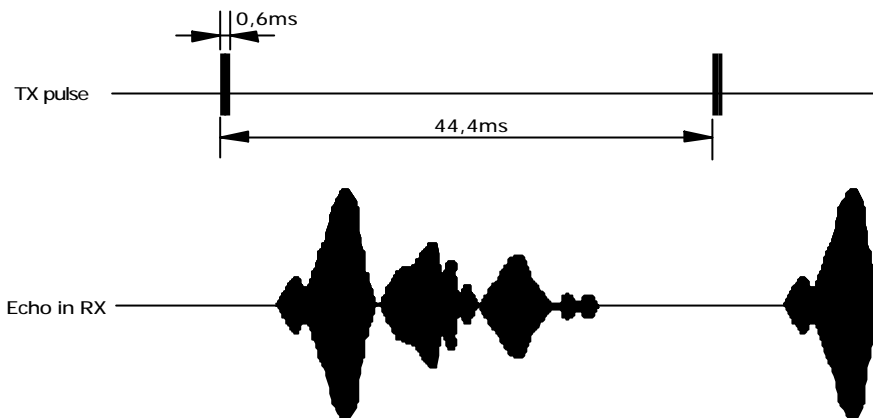

Fig. 1 - Pulse/Echo Timing

### Supply / Power-On Reset

The AS8413 requires a single 5-volt power supply. Pins for VDD and GND are separated for the analog and digital circuits, and a 100-n-F ceramic decoupling capacitor is recommended for each pair.

There is an internal power-on-reset circuit that initializes the IC after each power-up. The VDD rise time must be less than 20 ms, to guarantee proper initialization. Optionally, the IC can also be reinitialized with a rising-edge at the pin 17, if requested by the application.

### Time Reference

A clock must be present at the OSCIN input. The frequency may be selected to be either 40 kHz or 400 kHz, by setting the SEL40K input to '1' or '0' respectively. For the 40 kHz clock a duty-cycle of approximately 50% is necessary.

The clock signal can be created in several possible ways:

- Generation by a microprocessor or other external circuit
- Built-in oscillator with an external 40-kHz crystal between OSCIN and OSCOUT. Depending on the crystal, a load capacitor (about 22 pF) may be needed at OSCOUT.
- Built-in oscillator with an external 400-kHz ceramic resonator between OSCIN and OSCOUT. Load capacitors of at least 100 pF are necessary at the pins, according to the resonator specifications. The IC power consumption increases with higher capacitor values ( $I_{dd} = 1.0$  mA with 100 pF capacitors).

Optionally one of the AS8413 ICs used in a system may have its built-in oscillator and generate clock to the other IC from its COSC output. A driver would be needed, if IC's are not adjacent.

### ***Master/slave synchronization***

The AS8413 is intended to be used in intrusion detector systems where more than one pair of transducers is used. Each IC is able to control a single transmitter /receiver pair. In multiple-transducer systems it is necessary that the bursts generated by each transmitter are synchronized. Otherwise, the echoes may slip over each other and cause undesirable effects, such as false alarms.

Each AS8413 IC can be programmed to be either a master that generates an external delayed sync signal or a slave. This signal may come from the master or from an external circuit, such as a microcontroller. The sync signal received at the slave is delayed by half transmission period (22.2 ms) to the internal sync signal used by the master, in order to avoid burst superposition as much as possible.

The AS8413 can be configured to operate under 3 possible conditions, by programming the MODE input in one of the three possible conditions:

- logic '0': slave (receives delayed sync)
- logic '1': master in a multi-pair system (generates delayed sync)
- open: master in a single-pair system (AS8412 mode)

### ***Ultrasonic Transducers***

The AS8413 is compatible with standard 40-kHz ultrasonic transducers, available from several manufacturers. For each IC, one transducer is used to transmit the sonar pulses and one other to receive the echoes reflected inside the vehicle. Internal lengths up to 3.5 meters can be covered.

In most applications, just two pairs of sensors will be used. The sensors will typically be positioned at the B-pillars (central pillars), close to the roof, to provide the best possible coverage of all the vehicle interior. Each pillar may have either a transmitter/receiver pair or two sensors of the same kind. The first arrangement is recommended, as it allows a single box at each pillar containing the AS8413 and the transducer pair controlled by it, thus decreasing cabling.

The outputs TX1 and TX2 drive the transmitter in a push-pull configuration with 10 V peak-to-peak. As shown in Fig. 1, the transmission duty-cycle is very short (around 1/75), reducing the average current needed to generate the ultrasonic bursts to about 0.05 mA per IC.

Shielded cable is mandatory for the receiver and recommended for the transmitter, unless they are adjacent to the IC. The shield at the receiver cable must be grounded and connected to the RXGND pin.

## Analog Conditioning

The analog front-end, composed of a preamplifier and a filter centered at 40 kHz, increases the signal level and removes noise outside the bandpass. It is followed by a digitally-controlled AGC amplifier, that keeps signal level at the VCAP output within prescribed levels. Finally, an envelope detector extracts the information embedded in the amplified echo signal.

The front-end needs proper bias during power-up. That can be provided by an RC series circuit to VDD, as shown at Fig. 2, or alternatively, by the pre-amplifier of Fig. 4.

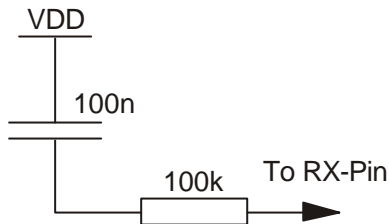

Fig. 2 - Series-RC circuit at RX

The AS8413 has a wide dynamic range, to follow the signal fluctuations that occur in a large variety of vehicles, sensors and environmental conditions. Only under extreme conditions, like in a larger vehicle, an external pre-amplifier at RX may help to improve performance. A practical way to verify if a pre-amplifier might be useful, is by monitoring the echo waveform at VCAP. For measuring that voltage a FET-input buffer (input impedance at least  $10^9$  ohm) should be used, as the output impedance at VCAP is very high. A pre-amplifier that satisfies the bias requirements is shown at the Fig. 4. Its gain is around 8 dB.

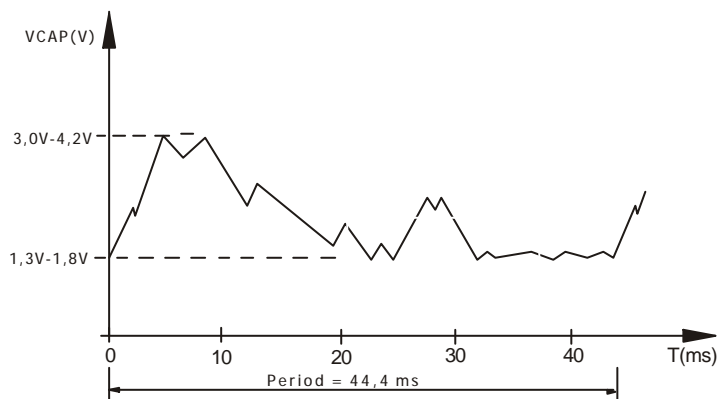

Fig. 3 - Waveform at VCAP



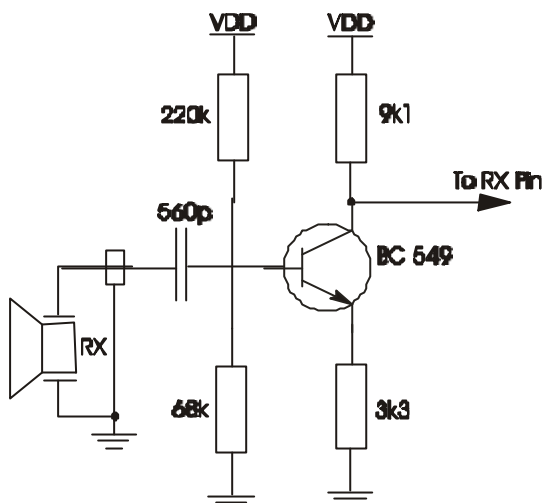

Fig. 4 - Recommended pre-amplifier

As a general rule, the best approach is to measure the voltage at the “valley”, that normally occurs at the end of the echo waveform. If it is above 1.8 V, then the system could benefit from some extra gain.

### Sensitivity Programming

The AS8413 allows the sensitivity to intrusions and movements to be programmed at production, so the manufacturer can adapt the detector to different requirements.

There are two possible ways of programming the sensitivity:

- Digital programming by the pins SENS1 and SENS0: controls the criteria used by the discriminator to validate intrusions or movements. Four sensitivities are available, as shown at Table 1.

**Table 1. Digital programmable sensitivities**

SENS1	SENS0	Sensitivity
1	1	High
1	0	Mid-high
0	1	Mid-low
0	0	Low

- Capacitor at the pin VCAP: controls the analog processing of the echo signal at the envelope detector. With smaller capacitors, the digitized echo signal will have a higher resolution and, as a result, a higher sensitivity will be obtained.

The best combination of digital programming and VCAP capacitor is usually determined by experiment. A generally good choice is to use sensitivity mid-high with a 270-pF capacitor at VCAP.

Table 2 shows some possible sensitivity combinations, marked according to the expected behavior at the field. It should be used as a guide to determine the best combination for each application.

**Table 2. Sensitivity as Function of Digital and VCAP Programming**

PROGRAM	390 pF	330 pF	270 pF	220 pF
High	OK	OK	+	+
Mid-high	-	OK	OK	+
Mid-low	-	-	OK	OK
Low	-	-	-	OK

(+) positions with higher sensitivities; may present false alarms under extreme conditions

(OK) most usual sensitivity combinations

(-) positions with lower sensitivities; may be useful for specific applications

### **The Self-Adjusting Sensitivity (SAS)**

The SAS (Self-Adjusting Sensitivity) control loop is a powerful feature that optimizes the sensitivity to intrusion and motion, based on the present environmental conditions. Under quiet situations the detector has a very high sensitivity. On the other hand, when certain disturbances such as thermal gradients appear inside the vehicle, the sensitivity is decreased to avoid possible false alarms.

The sensitivity range programmed by the manufacturer is not changed by the SAS, that simply selects the most adequate sensitivity for each situation within the allowed range. Fig. 5 gives a rough idea of how the SAS can affect the detector sensitivity, for a given capacitor at VCAP.

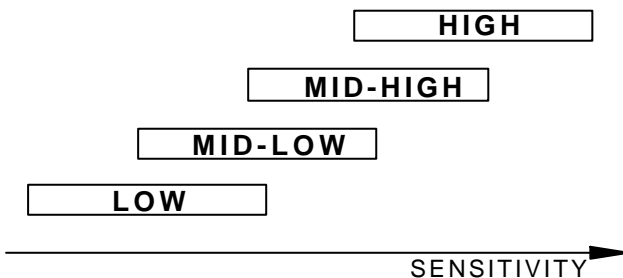

Fig. 5 - Sensitivity Ranges with SAS

The SAS actuation is controlled by the SAS input.

- SAS enabled (pin SAS = "1"):  
After power-on, the IC starts with the lowest sensitivity within the programmed range. The sensitivity will be constantly adjusted, according to the external conditions. Even under quiet conditions, the IC may take at least 2 minutes to reach the maximum allowed sensitivity. That should be considered during system evaluation.

- SAS disabled (pin SAS = "0")

The IC will keep the sensitivity fixed at the upper limit of the programmed range, regardless of the environmental conditions. This mode can be useful in special applications that demand a fixed or externally controlled sensitivity. The VCAP capacitor may have to be up to 4 times bigger than it would be with the SAS enabled, to compensate the fixed high sensitivity and avoid false alarms. Another use of this mode is to allow an easier characterization of the upper sensitivity limit during the system development.

The self-test indicates an error with SAS = "0". To generate a valid self-test, SAS must be "1" during power-up. It may be switched afterwards.

Together with the AGC, the SAS loop provides improved controllability over the intrusion detection process, allowing the system to be little affected by changes in the external conditions, such as temperature, supply voltage and sensitivity of the ultrasonic sensors.

In any case, the sensitivity can be very significant, so the AS8413 is not adequate to be used in convertibles or with open windows.

### ***DSP and Fuzzy-Logic Discriminator***

Many external phenomena may affect the ultrasonic waves inside the vehicle. Sunlight, blows at the glasses or roof, wind through the ventilation flaps are some examples.

Experiments have shown that a real intrusion can not be validated by a single specific characteristic of the echo waveform. Several parameters must be observed at the same time and also how they correlate with each other. Experimental data gathered from extensive field testing were used to support the detection criteria embedded in the AS8413.

To implement those criteria, first the digitized echoes are processed by a DSP circuit to enhance the parameters to be monitored. Then, a fuzzy-logic discriminator continuously examines how those parameters change and correlate, to verify any possible intrusion.

### ***Built-In-Self-Test***

When power is applied and SAS='1', the master AS8413 goes automatically into a self-test routine that checks the IC operation. It can also detect initialization errors due to a slow supply rise time or a clock problem at OSCIN. The self-test does not operate in a slave IC.

During the self-test period, the IC outputs are exercised and should be ignored. If the test is successful, normal operation starts, indicated by the output LED pulsing periodically.

In the case of an IC malfunction, immediately after the self-test the  $\overline{\text{LED}}$  and  $\overline{\text{WARN}}$  outputs are turned on (low) for about 4.4 seconds. If a light-emitting diode is connected to the  $\overline{\text{LED}}$  output, the self-test message may be seen directly by the user.

After an error message, the LED starts to blink again, as in a normal operation. Fig. 6 shows the possible self-test waveforms after power-on.

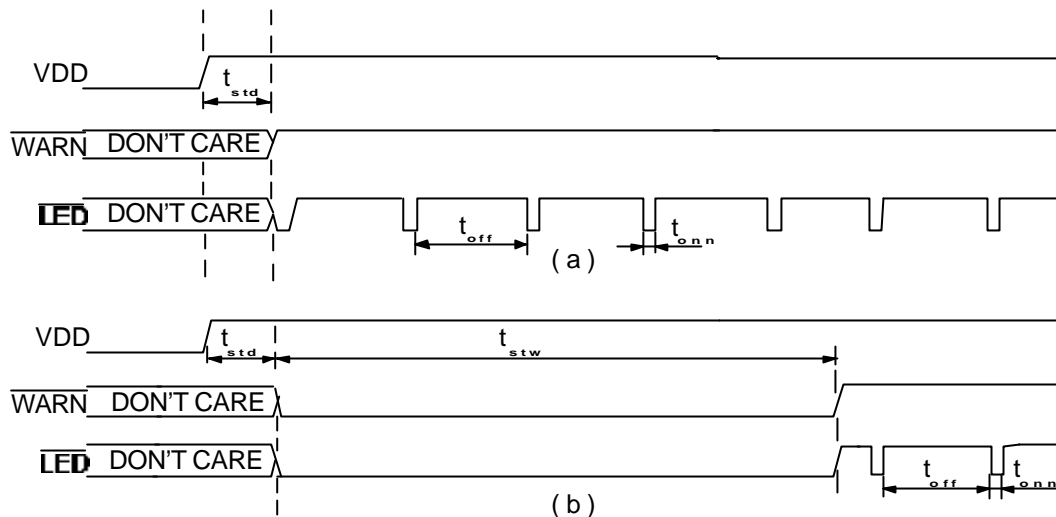

Fig. 6  
(a) Self-Test OK  
(b) Error at Self-Test

## Alarm Signalling

The AS8413 can indicate not only intrusion or motion, but also other kinds of disturbance, and send a particular message for each situation. Those disturbances are defined as follows and the messages are identified at Table 3.

- Weak intrusion: early stages of an intrusion, or a weaker intrusion or movement. Detection criteria are similar to those for intrusion, but with higher sensitivity.
- Blockage: elimination of the coupling between the transducers, either by blocking one of them, or by cutting a wire.
- Saturation: very strong 40-kHz signal at RX, possibly an attempt to sabotage the alarm system by saturating the receiver. May also be caused by a glass breakage or by strong hits with hard objects at the glass.

With this signalling scheme, the IC has flexibility to be used either in simpler applications or in sophisticated microprocessor based systems. In addition, the manufacturer has the option to choose which kind of disturbance should be an alarm condition.

The pulse widths are those specified in the AC electrical Characteristics and shown in Fig. 7. At ALARM and WARN they are at least 200ms; the outputs remain active if intrusion or motion persists.

The WARN output could be used instead of the ALARM, if only intrusion detections should be flagged. In this case, the digital sensitivity should be scaled one step over (for instance from mid-high to mid-low), or the capacitor at VCAP increased, to keep approximately the same sensitivity.

The blockage and saturation are signaled just one time at each occurrence, to avoid continuous alarm triggering. Detection of glass breakage by saturation is not guaranteed.

**Table 3. Disturbances detected by the AS8413**

LED	ALARM	WARN	Conditions
pulsing	1	1	no disturbance
pulsing	1	0	weak intrusion
0	0	0	intrusion
pulsing	0	1	blockage
0	0	1	saturation

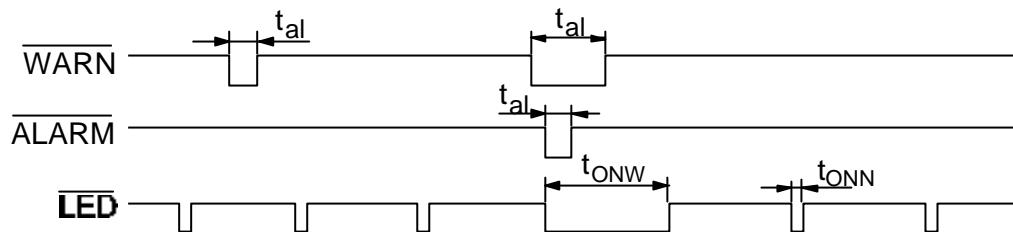

Fig. 7 - Weak Intrusion Followed by an Intrusion

### Courtesy Entry/Exit Time

The pin ALEN is an optional alarm enable input that can be used to provide a courtesy entry and/or exit time. When tied to VDD, normal alarm operation is enabled. If ALEN is grounded, the outputs ALARM, WARN and LED are disabled, except during the self-test, when LED indicates the test result.

By grounding ALEN, the IC can be made inoperative as seen by the control unit and still keep its internal processing. This is useful when intrusion detections must be temporarily inhibited, or to block self-test pulses at ALARM and WARN.

During the first 10 or 20 seconds after shutting a door in a hot and sunny day, an alarm indication may occur, due to thermal gradients inside the vehicle. That should be considered when choosing a courtesy time for a AS8413-based system. When a RC circuit connected to the supply voltage is applied to ALEN, the courtesy time after power-up is given by:

$$T \approx 0.92 \times R \times C$$

## Application Circuit

A typical Application Circuit for the AS8413 is presented at Fig. 8, where a 400 kHz oscillator with external ceramic resonator is built for each IC. This circuit is suitable to be used in a microcontroller-based alarm system.

Optionally, the microcontroller could synthesize a 40 kHz for the ICs, decreasing component count and power at the system level. The digital sensitivity also can be controlled, in specific applications.

If access to all the signalling outputs of both ICs is provided, the alarm system will be able to identify the kind of disturbance detected and the region where it occurred.

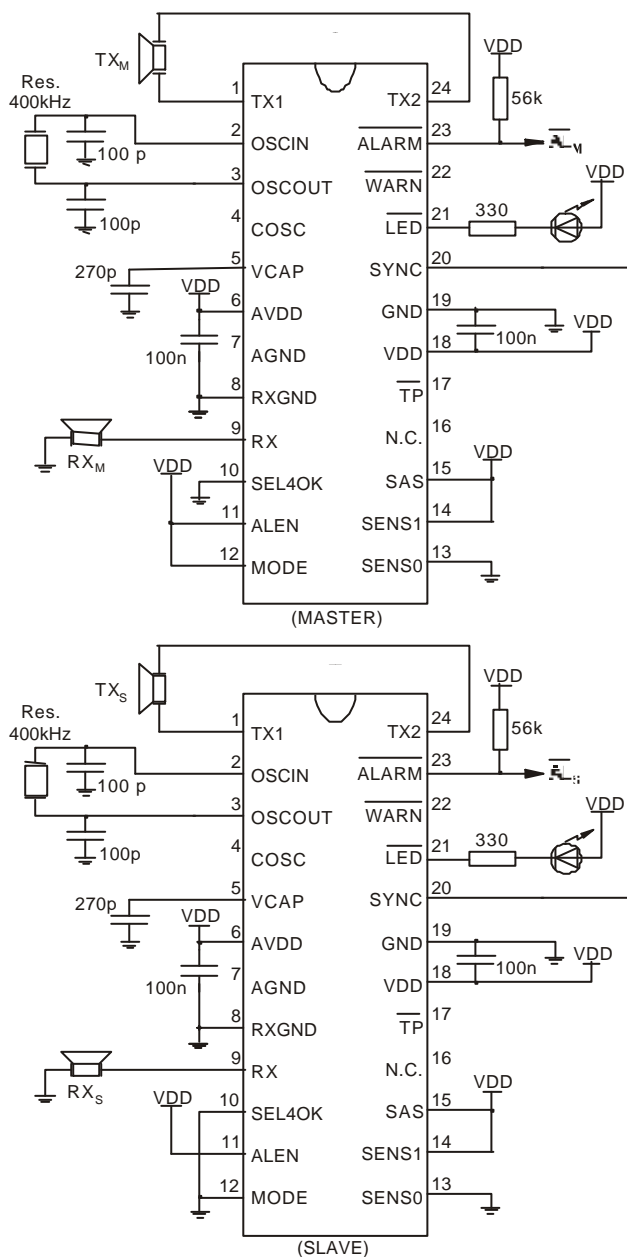

Fig. 8 - Application Circuit

## EMI Protection

The usual precautions against EMI, such as PCB with ground plane, short tracks and shielded cables, are recommended for AS8413 applications, to avoid possible effects from noise induced by external sources.

The RX cable must be shielded, because of the low-voltage signal. An alternative to protect other pins directly connected to unshielded cables, is to clamp induced voltages with signal diodes close to the pins (Fig.9)

If a single shielded cable is used for the transmitting sensor, the internal wire may be connected to TX1 and the shield connected to TX2. In this case, only the TX2 output will need protection diodes

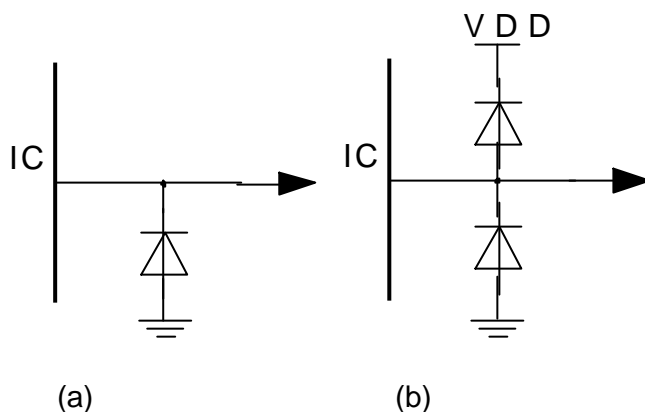

Fig. 9 - Diode Clamp Protection for Unshielded Cables

(a) pins 1, 24

(b) pins 21, 22, 23