

Selected Packages
U.L. RECOGNIZED
File #E71639

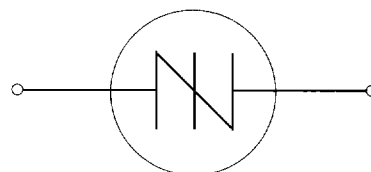
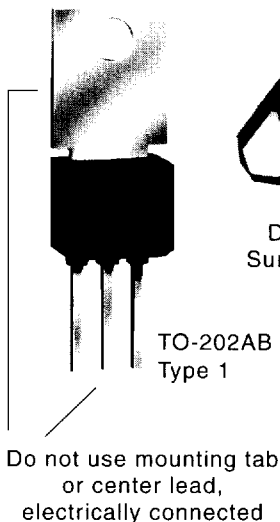
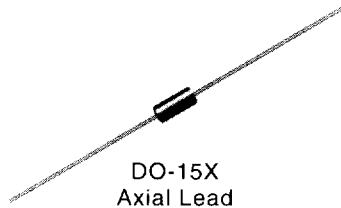

SIDAC

(95 - 330 Volts)

General Description

The Sidac is a silicon bilateral voltage triggered switch with greater power-handling capabilities than standard diacs. Upon application of a voltage exceeding the Sidac breakover voltage point, the Sidac switches on through a negative resistance region to a low on-state voltage. Conduction will continue until the current is interrupted or drops below the minimum holding current of the device.

Teccor offers the complete voltage range (95-330) over three different packages:

- TO-92 (95-280 volts)
- Axial lead DO-15X (95-330 volts)
- Surface Mount DO-214AA (95-330 volts)
- TO-202AB (190-330 volts)

Teccor's Sidacs feature glass passivated junctions to ensure a rugged and dependable device capable of withstanding harsh environments.

Variations of devices covered in this data sheet are available for custom design applications. Please consult the factory for more information.





Applications

- High voltage lamp ignitors
- Natural gas ignitors
- Gas oil ignitors
- High voltage power supplies
- Xenon ignitors
- Over voltage protector
- Pulse generators
- Fluorescent lighting ignitors
- HID lighting ignitors

Features

- AC circuit oriented
- Glass-passivated junctions
- High surge current capability

Electrical Specifications

Type	Part No.				$I_{T(RMS)}$	V_{DRM}	V_{BO}		I_{DRM}	I_{BO}
	 TO-92 E Package	 DO-15X G Package	 TO-202AB F Package	 DO-214AA S Package	On-State RMS Current $T_J \leq 110^\circ\text{C}$ 50/60Hz Sine Wave (7) (8) Amps	Repetitive Peak Off-State Voltage Volts	Breakover Voltage 50/60Hz Sine Wave (1) Volts		Repetitive Peak Off-State Current 50/60Hz Sine Wave $V = V_{DRM}$ μAmps	Breakover Current 50/60Hz Sine Wave μAmps
See "Package Dimensions" section for variations.					MAX	MIN	MIN	MAX	MAX	MAX
K1050E70	K1050G		K1050S	1.0	± 90	95	113	5	10	
K1100E70	K1100G		K1100S	1.0	± 90	104	118	5	10	
K1200E70	K1200G		K1200S	1.0	± 90	110	125	5	10	
K1300E70	K1300G		K1300S	1.0	± 90	120	138	5	10	
K1400E70	K1400G		K1400S	1.0	± 90	130	146	5	10	
K1500E70	K1500G		K1500S	1.0	± 90	140	170	5	10	
K2000E70	K2000G	K2000F1	K2000S	1.0	± 180	190	215	5	10	
K2200E70	K2200G	K2200F1	K2200S	1.0	± 180	205	230	5	10	
K2400E70	K2400G	K2400F1	K2400S	1.0	± 190	220	250	5	10	
		K2401F1		(10)	± 190	220	250	5	10	
K2500E70	K2500G	K2500F1	K2500S	1.0	± 190	240	280	5	10	
	K3000G	K3000F1	K3000S	1.0	± 190	270	330	5	10	

General Notes

- All measurements are made at 60Hz with a resistive load at an ambient temperature of $+25^\circ\text{C}$ unless otherwise specified.
- Storage temperature range (T_S) is -65°C to $+150^\circ\text{C}$.
- The case (T_C) or lead (T_L) temperature is measured as shown on the dimensional outline drawings. See "Package Dimensions" section of this catalog.
- Junction temperature range (T_J) is -40°C to $+110^\circ\text{C}$.
- Lead solder temperature is a maximum of $+230^\circ\text{C}$ for 10 seconds maximum; $\geq 1/16"$ (1.59mm) from case.

Electrical Specification Notes

- (1) See Figure 9.6 for V_{BO} change vs junction temperature.
- (2) See Figure 9.7 for I_{BO} vs junction temperature.
- (3) See Figure 9.2 for I_H vs case temperature.
- (4) See Figure 9.14 for test circuit.
- (5) See Figure 9.1 for more than one full cycle rating.
- (6) $R_{\theta JA}$ for TO-202 Type 23 and Type 41 is $70^\circ\text{C}/\text{watt}$.
- (7) $T_C \leq 80^\circ\text{C}$ for TO-92 Sidac and $T_C \leq 100^\circ\text{C}$ for TO-202 Sidacs.
 $T_L \leq 85^\circ\text{C}$ for DO-15X and $T_L \leq 75^\circ\text{C}$ for DO-214AA.
- (8) See Figure 9.15 for clarification of Sidac operation.
- (9) For best Sidac operation, the load impedance should be near or less than switching resistance.
- (10) Teccor's new, improved series of sidacs is designed to ensure good commutation at higher switching frequencies as required in ignitor circuits for high intensity discharge (HID) lighting. A typical circuit for a metal halide lamp ignitor is shown in the schematic, Figure 9.3. With proper component selection this circuit will produce three pulses for ignition of Osram lamp types such as HQI-T70W, HQI-T150W, and HQI-T250W which require a minimum of three pulses at 4kV magnitude and $>1\mu\text{s}$ duration each at a minimum repetition rate of 3.3kHz.

I_H		V_{TM}				I_{TSM}		R_S	dV_Q/dt	dv/dt	di/dt
Dynamic Holding Current 50/60Hz Sine Wave $R = 100\Omega$ (3) (4)		Peak On-State Voltage $I_T = 1$ Amp				Peak One Cycle Surge Current 50/60Hz Sine Wave (Non-Repetitive) (5)		Switching Resistance $R_S = \frac{(V_{BO} - V_S)}{(I_S - I_{BO})}$ 50/60Hz Sine Wave (9)	Critical Rate-of-Rise of Turn-off Voltage at 8kHz	Critical Rate-of-Rise of Off-State Voltage at Rated V_{DRM} $T_J \leq 100^\circ C$	Critical Rate-of-Rise of On-State Current
		Volts Max									
		TYP	MAX	Package							
		E	G	F	S			MIN	MIN	MIN	TYP
60	150	1.5	1.5		1.5	20	16.7	0.1	20	1500	150
60	150	1.5	1.5		1.5	20	16.7	0.1	20	1500	150
60	150	1.5	1.5		1.5	20	16.7	0.1	20	1500	150
60	150	1.5	1.5		1.5	20	16.7	0.1	20	1500	150
60	150	1.5	1.5		1.5	20	16.7	0.1	20	1500	150
60	150	1.5	1.5	3.0	1.5	20	16.7	0.1	20	1500	150
60	150	1.5	1.5	3.0	1.5	20	16.7	0.1	20	1500	150
60	150	1.5	1.5	3.0	1.5	20	16.7	0.1	20	1500	150
60	150			3.0		20	16.7	2.0	42	1500	150
60	150	1.5	1.5	3.0	1.5	20	16.7	0.1	20	1500	150
60	150		1.5	3.0	1.5	20	16.7	0.1	20	1500	150

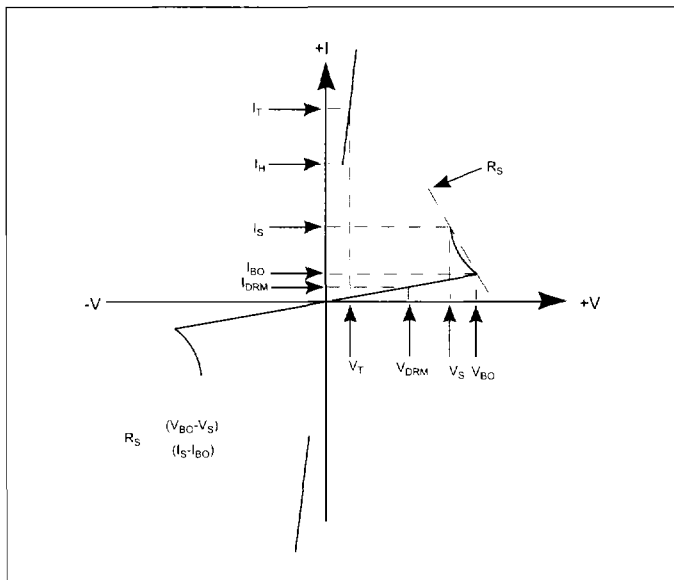

V-I Characteristics

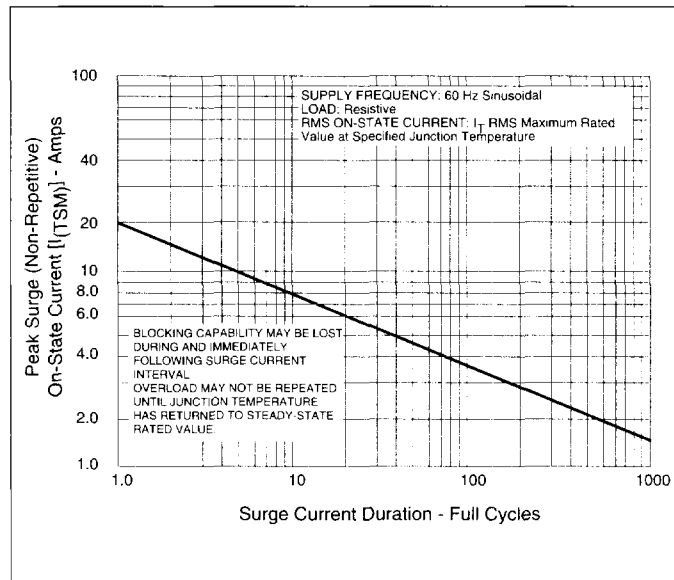

Figure 9.1 Peak Surge Current vs Surge Current Duration

THERMAL RESISTANCE (STEADY STATE) $R_{\theta JC}$ [$R_{\theta JA}$] °C/W (TYPICAL)			
E	G	F (6)	S
50 [105]	28 [79]	8 [45]	32 [90]

Electrical Specifications

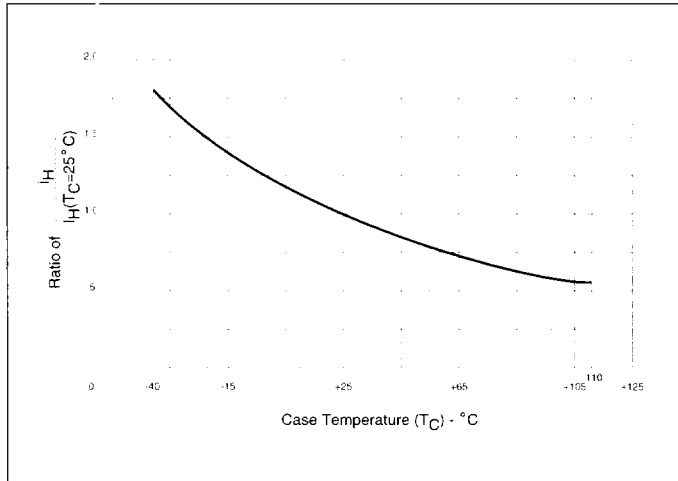

Figure 9.2 Normalized DC Holding Current vs Case/Lead Temperature

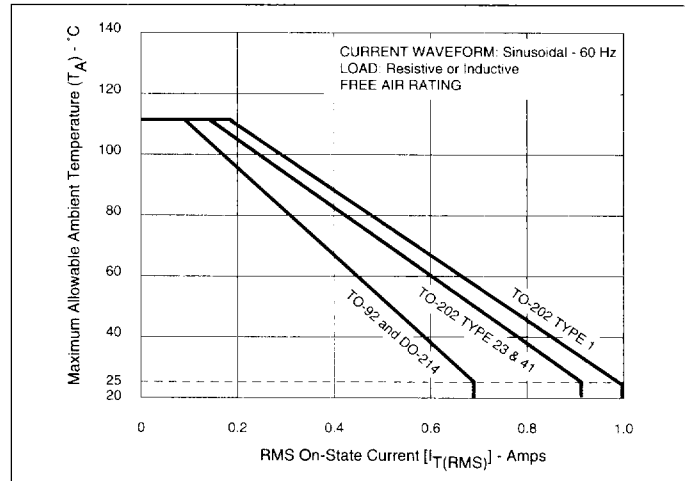

Figure 9.5 Maximum Allowable Ambient Temperature vs On-State Current

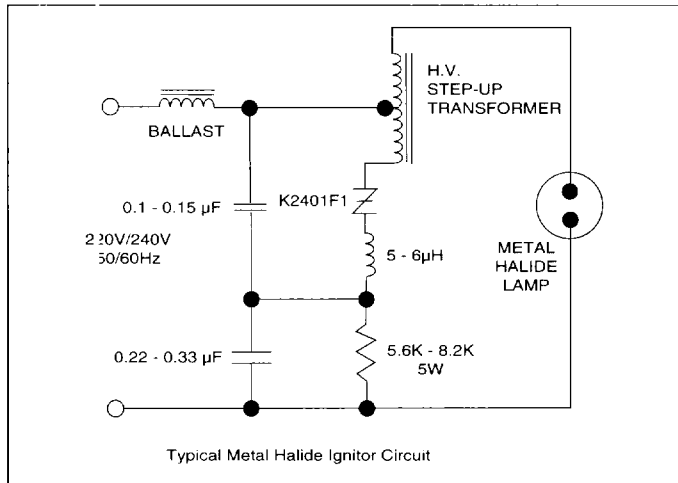

Figure 9.3 Typical Metal Halide Ignitor Circuit

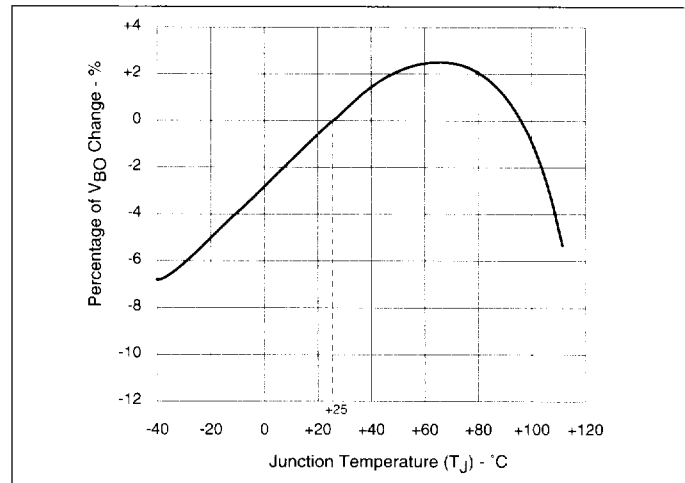

Figure 9.6 Normalized V_{BO} Change vs Junction Temperature

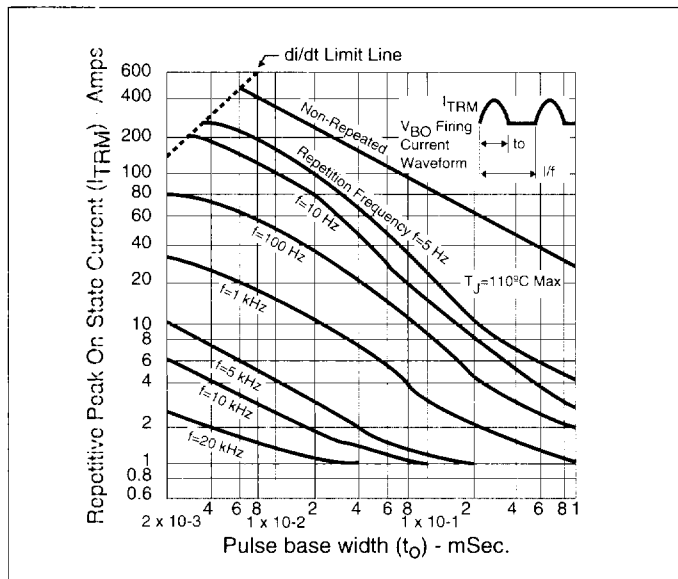

Figure 9.4 Repetitive Peak On-State Current (I_{TRM}) vs Pulse Width at Various Frequencies

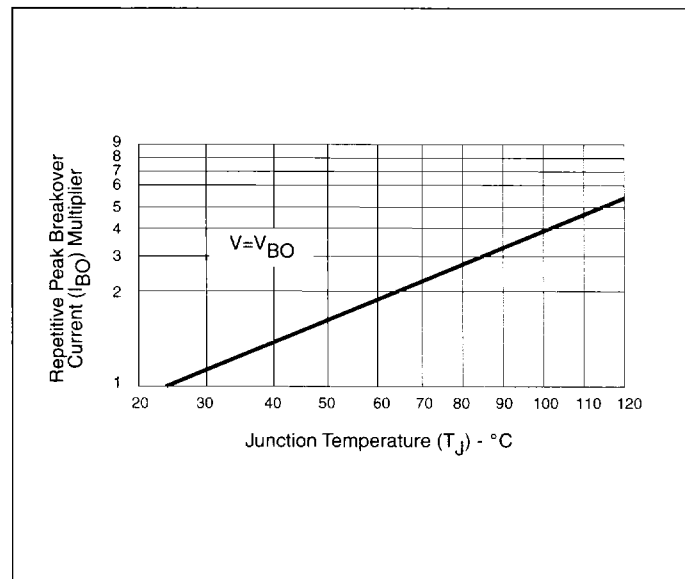

Figure 9.7 Normalized Repetitive Peak Breakover Current vs Junction Temperature

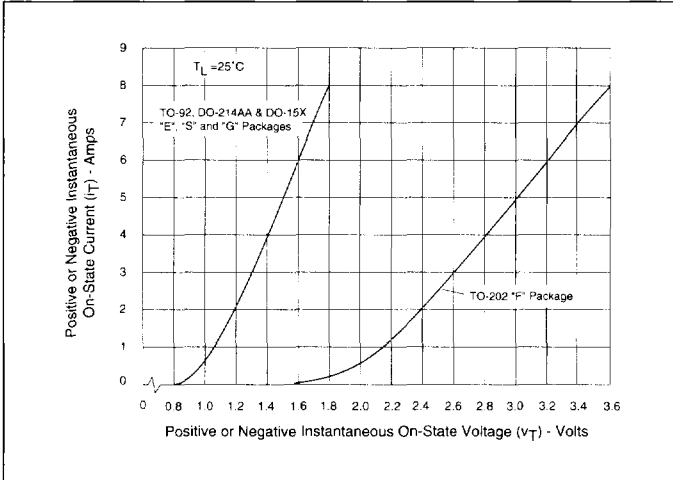

Figure 9.8 On-State Current vs On-State Voltage (Typical)

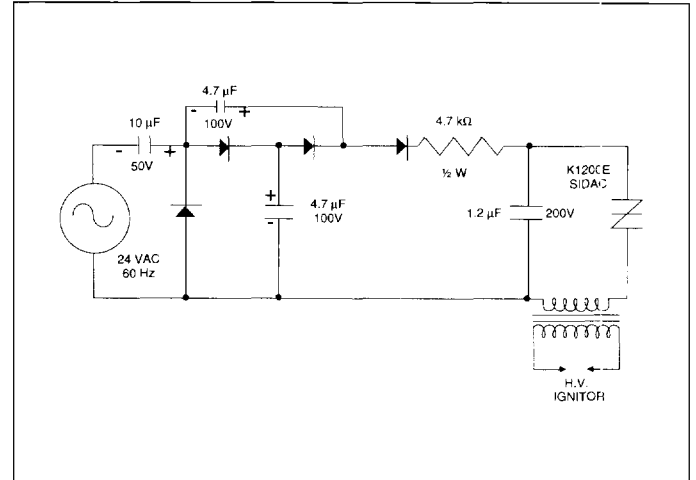

Figure 9.11 Ignitor Circuit (Low Voltage Input)

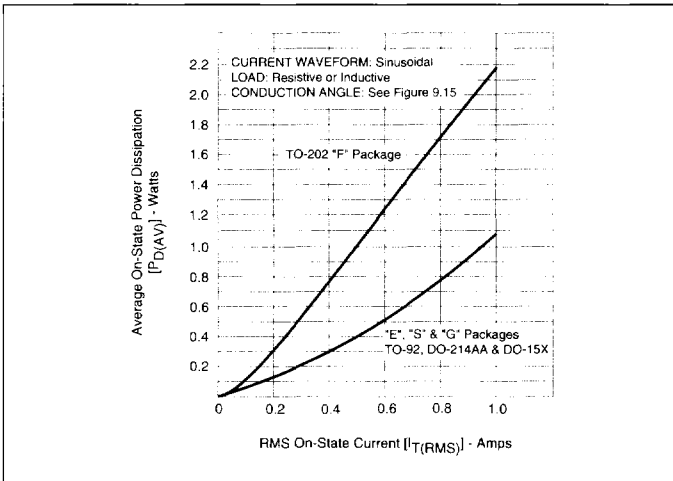

Figure 9.9 Power Dissipation (Typical) vs On-State Current

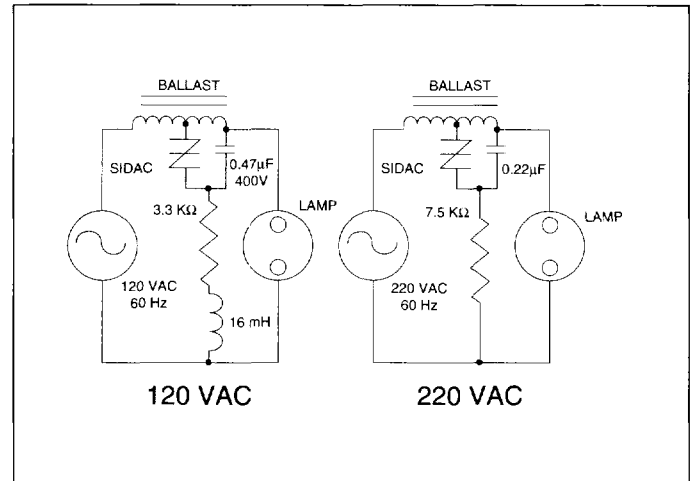

Figure 9.12 Typical High Pressure Sodium Lamp Firing Circuit

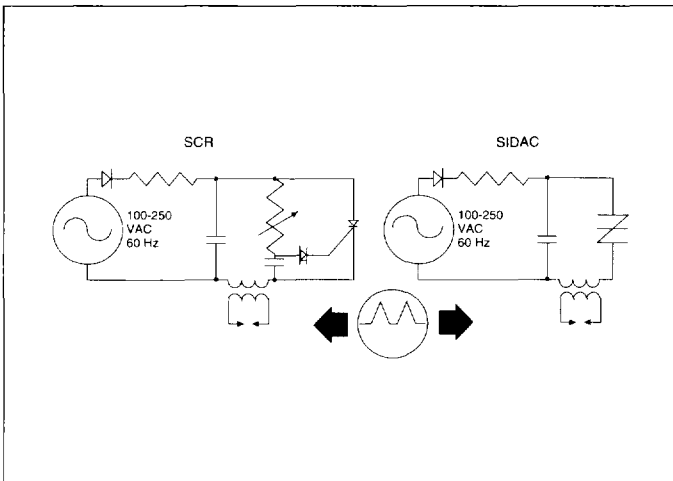

Figure 9.10 Comparison of Sidac vs SCR

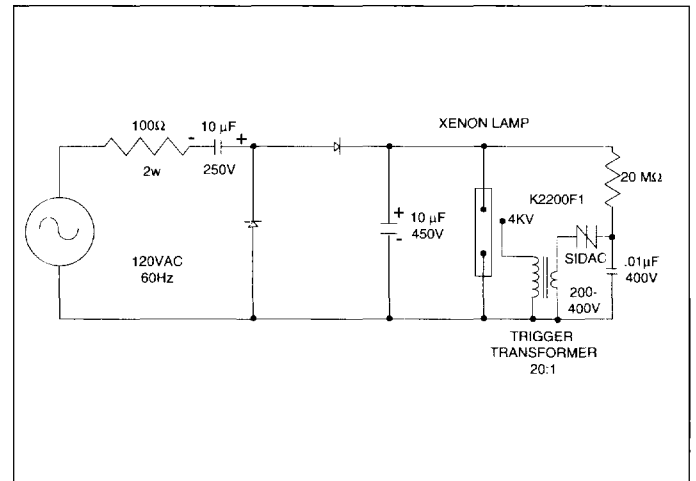

Figure 9.13 Xenon Lamp Flashing Circuit

Electrical Specifications

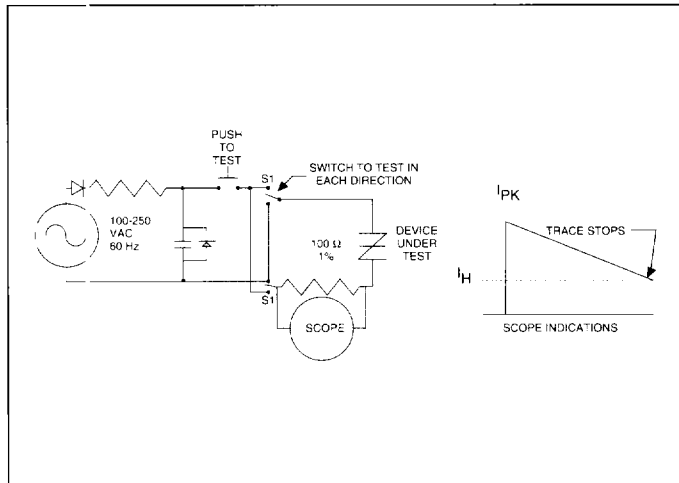

Figure 9.14 Dynamic Holding Current Test Circuit for Sidacs

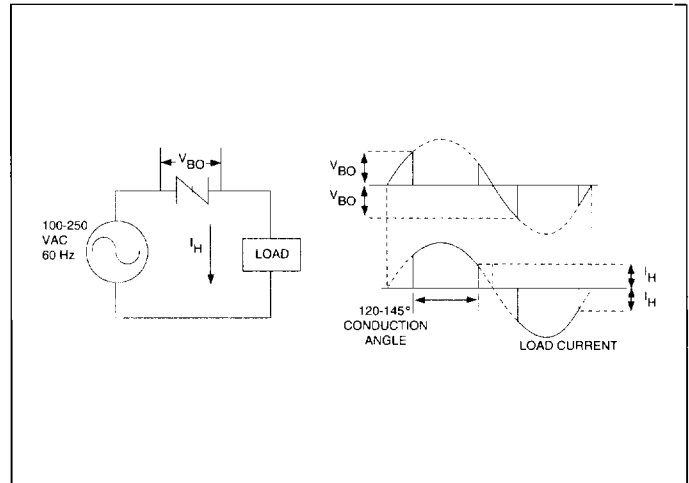

Figure 9.15 Basic Sidac Circuit

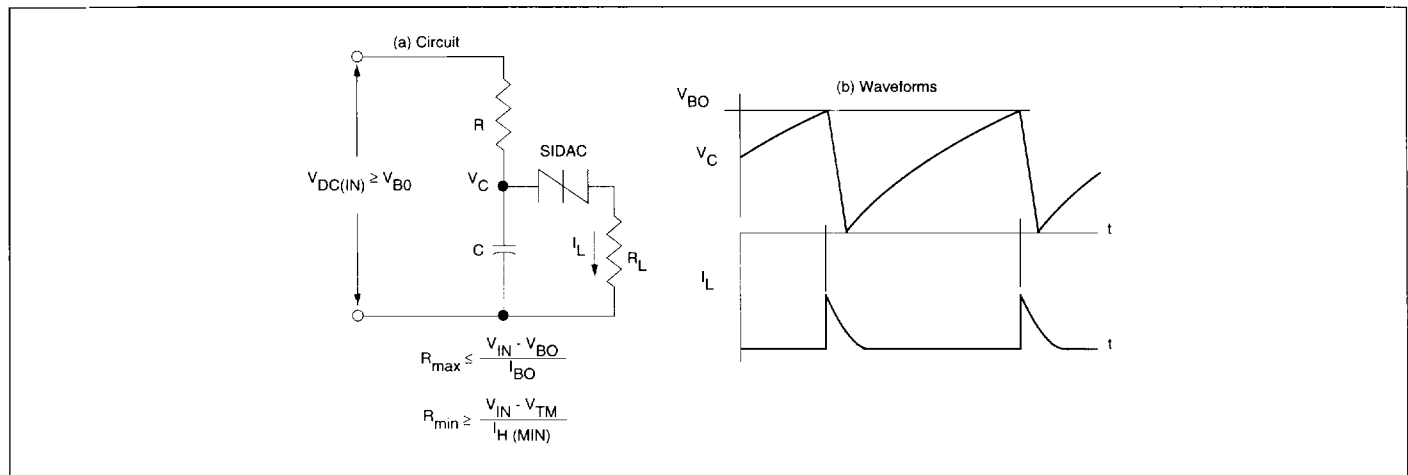

Figure 9.16 Relaxation oscillator Using a Sidac

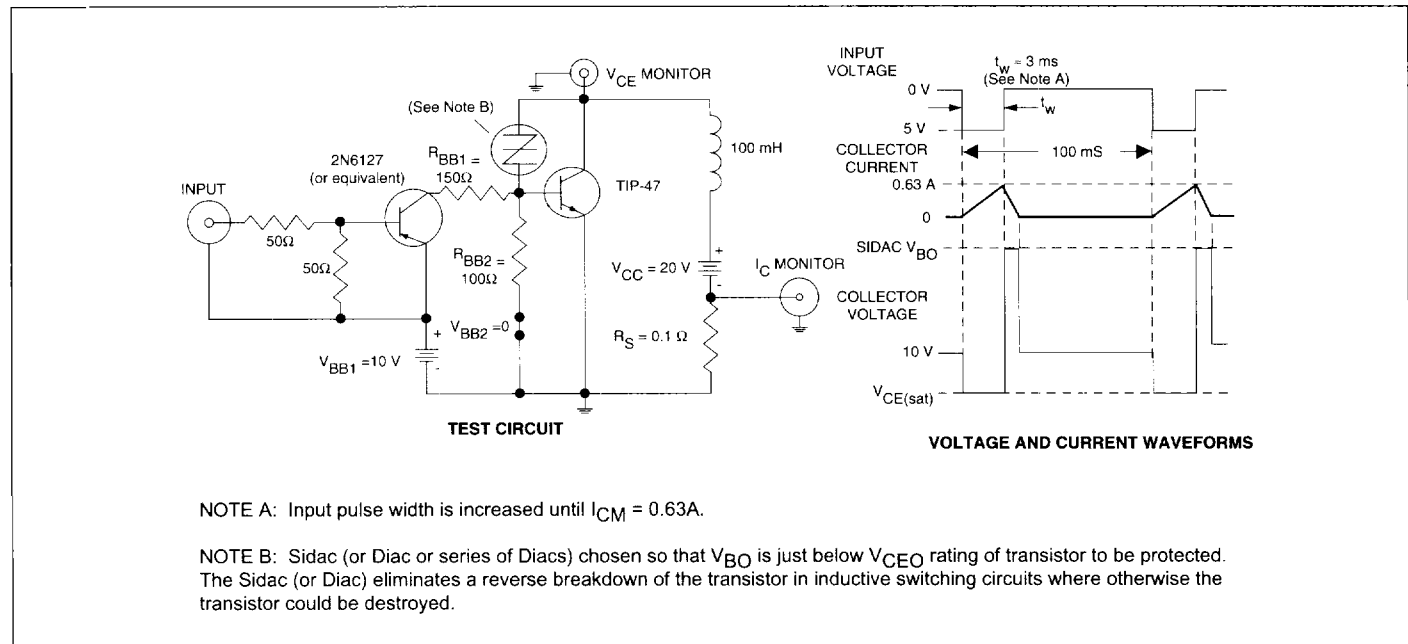

Figure 9.17 Sidac Added to Protect Transistor for Typical Transistor Inductive Load Switching Requirements