

9-20 V Continuous Input	0-20V Outputs	80A Current	Non-Isolated	Half-brick DC-DC Converter
-----------------------------------	-------------------------	-----------------------	---------------------	--------------------------------------

The NiQor Half-brick dc-dc converter is a non-isolated buck-boost regulator, which employs synchronous rectification to achieve extremely high conversion efficiency. The High Input Voltage NiQor Brick family of converters can be used in traditional DPA (distributed power architecture) systems or provide a regulated output voltage from a battery source or other variable voltage source. The NiQor Half-brick family can be configured to Buck the input voltage down to a lower voltage or Boost the input voltage up to a higher voltage using a single external resistor. These modules are RoHS 6/6 compliant (see page 7).

NiQor®

Non-Isolated

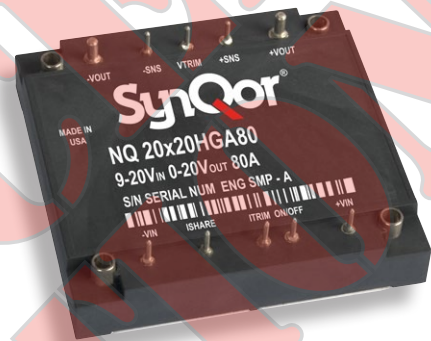

NiQor Half-brick module

Operational Features

- High efficiency, 95% at full rated load current
- Delivers up to 80A of output current
- Input Voltage Range: 9-20 Vdc
- Output Voltage Range: 0-20V (negative output is possible)
- Extensive on-board input and output filtering
- No minimum load requirement means no preload resistors required
- Buck or buck-boost versions available
- Adjustable current limit with current monitor (F option)

Mechanical Features

- Industry standard half-brick pin-out configuration
- Standard size: 2.49" x 2.39" (63.1mm x 60.6mm)
- Total height only 0.512" (13.0 mm)
- Total weight: Encased - TBD

Control Features

- On/Off control
- Output voltage trim permits custom voltages
- Remote Sense (S option, standard)
- Current limit trim (F option)
- Output voltage trim range of -10%, +10%

Protection Features

- Input under-voltage lockout protects the converter at low input voltage conditions
- Over-current shutdown protects converter from excessive load current or short circuits
- Input/output over-voltage protection protects load and regulator from damaging voltages
- Thermal shutdown protects converter from abnormal environmental conditions

Safety Features

Pending

- EN60950-1:2006 / A11:2009 / A1:2010
- UL 60950-1:2007
- CAN/CSA-C22.2 No. 60950-1:2003

Contents

	Page No.
Standard Mechanical Diagram	2
Flanged Mechanical Diagram	3
Technical Specification	4
Ordering Information	7

Input: 9-20 V
Outputs: 0-20V
Current: 80A
Package Half-brick

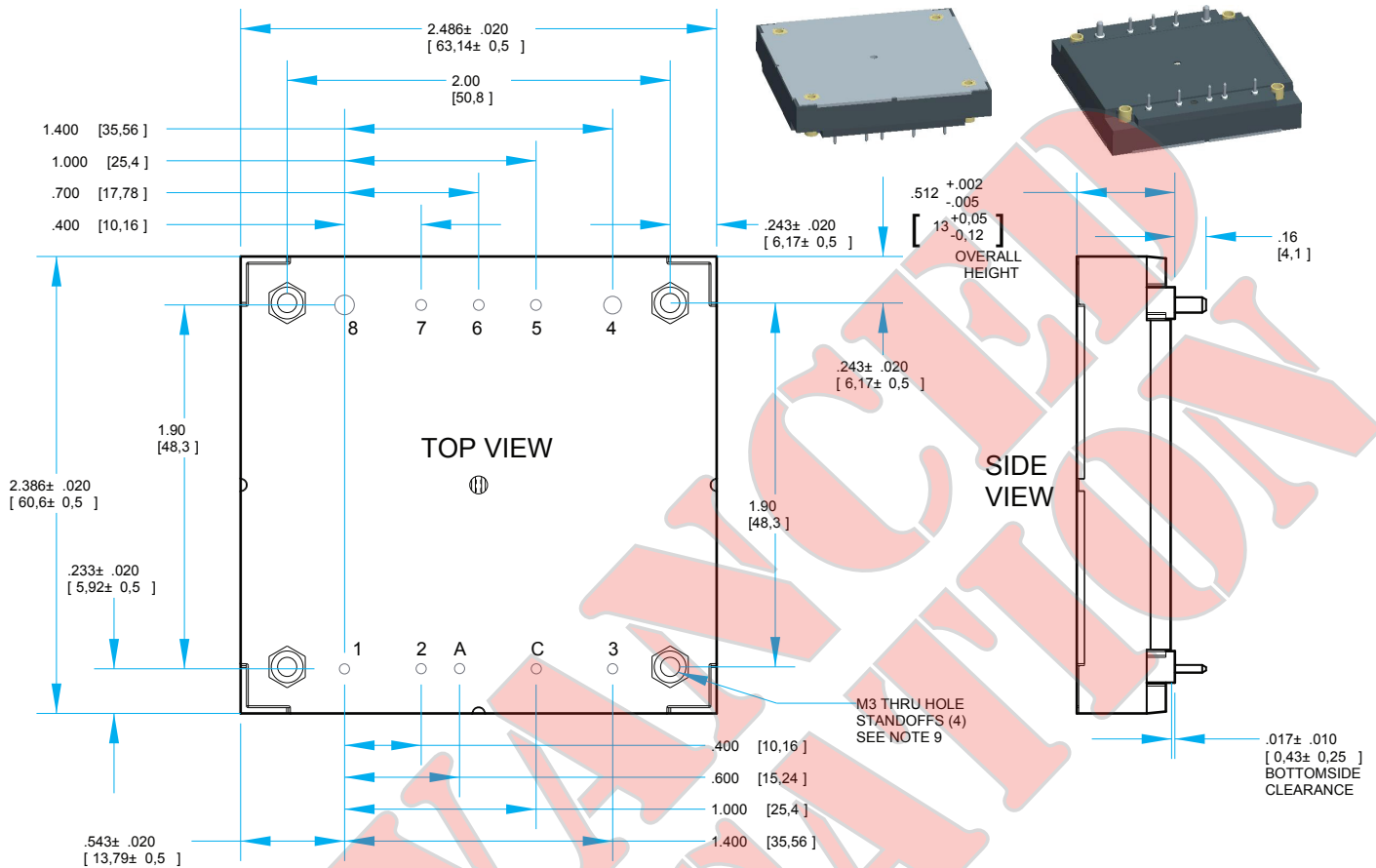

NOTES

PIN DESIGNATIONS

- 1) Applied torque per screw should not exceed 6in lb (.7Nm)
- 2) Baseplate flatness tolerance is 0.004" (.10mm) TIR for surface
- 3) Pins 1-3, 5-7, A, and C are 0.040" (1.02mm) dia. with 0.080" (2.03mm) dia. standoff shoulders
- 4) Pins 4 and 8 are 0.080" (2.03mm) dia. with .125" (3.18) dia. standoff shoulders
- 5) All pins: Material: Copper Alloy, Finish: Matte Tin over Nickel Plate
- 6) Undimensioned components are shown for visual reference only
- 7) All dimensions in inches[mm]. Tolerances: X.XXXIN +/-0.02 (X.Xmm +/-0.5mm) X.XXXIN +/-0.010 (X.XXmm +/-0.25mm)
- 8) Weight: TBD
- 9) Threaded or non-threaded options available
- 10) Workmanship: Meets or exceeds IPC-A-610 Class II

Pin	Label	Function
1	Vin(+)	Positive input
2	ON/OFF	TTL input to turn converter on and off, referenced to Vin(-), with internal pull up
A	ITRIM	Output current trim
C	ISHARE	Current share
3	Vin(-)	Negative input voltage
4	Vout(-)	Negative output voltage
5	SENSE(-)	Negative remote sense. See note 1
6	VTRIM	Output voltage trim
7	SENSE(+)	Positive remote sense. See note 2
8	Vout(+)	Positive output voltage

Notes:

- 1)SENSE(-) should be connected to Vout(-) either remotely or at the converter
- 2)SENSE(+) should be connected to Vout(+) either remotely or at the converter.

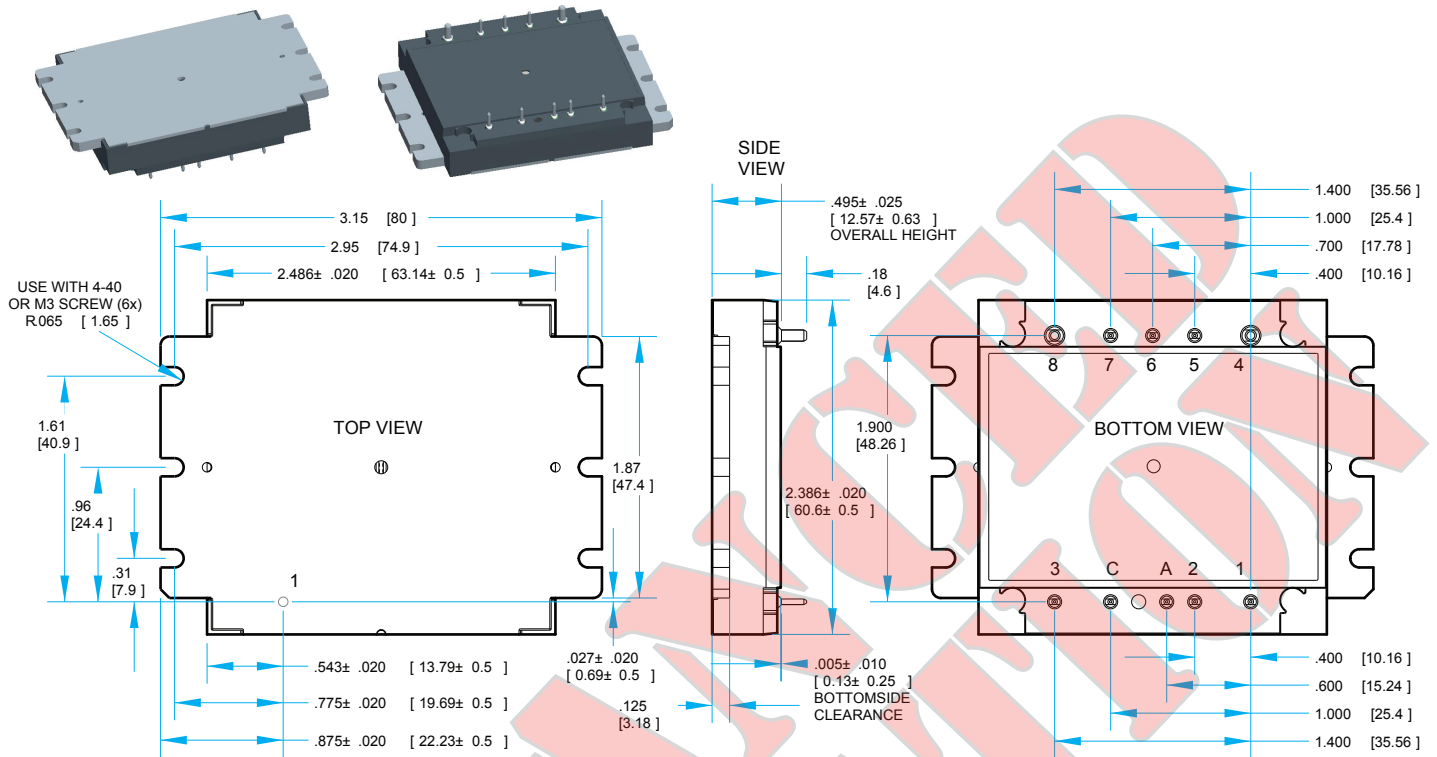

NOTES

- 1) Applied torque per screw should not exceed 5in lb, 3 in-lb recommended.
- 2) Baseplate flatness tolerance is 0.01" (.10mm) TIR for surface
- 3) Pins 1-3, 5-7, A, and C are 0.040" (1.02mm) dia. with 0.080" (2.03mm) dia. standoff shoulders
- 4) Pins 4 and 8 are 0.080" (2.03mm) dia. With .125" (3.18) dia. standoff shoulders
- 5) All pins: Material: Copper Alloy, Finish: Matte Tin over Nickel Plate
- 6) Undimensioned components are shown for visual reference only
- 7) All dimensions in inches[mm], Tolerances: X.XXIN +/-0.02 (X.Xmm +/-0.5mm) X.XXXIN +/-0.010 (X.XXmm +/-0.25mm)
- 8) Weight: TBD
- 9) Workmanship: Meets or exceeds IPC-A-610 Class II

PIN DESIGNATIONS

Pin	Label	Function
1	Vin(+)	Positive input
2	ON/OFF	TTL input to turn converter on and off, referenced to Vin(-), with internal pull up
A	ITRIM	Output current trim
C	ISHARE	Current share
3	Vin(-)	Negative input voltage
4	Vout(-)	Negative output voltage
5	SENSE(-)	Negative remote sense. See note 1
6	VTRIM	Output voltage trim
7	SENSE(+)	Positive remote sense. See note 2
8	Vout(+)	Positive output voltage

Notes:

- 1)SENSE(-) should be connected to Vout(-) either remotely or at the converter
- 2)SENSE(+) should be connected to Vout(+) either remotely or at the converter.

NQ20x20HGx80 Electrical Characteristics

Ta = 25 °C, airflow rate = 300 LFM, Vin = 12 V dc unless otherwise noted; full operating temperature range is -40 °C to +105 °C ambient temperature with appropriate power derating. Specifications subject to change without notice.

Parameter	Vout	Min.	Typ.	Max.	Units	Notes & Conditions
ABSOLUTE MAXIMUM RATINGS						
Input Voltage						
Non-Operating	All	0		30	V	Continuous
Operating	All			20	V	Continuous
Storage Temperature	All	-55		125	°C	
Voltage at ON/OFF input pin	All	0		5.5	V	
RECOMMENDED OPERATING CONDITIONS						
Input Voltage Range	All	9		20	V	Turn on at 10V
Input Fuse Rating	All			100	A	Fast blow external fuse recommended
Input Current				80	A	Input current max equals output rated current
External Input Capacitance	All	100			µF	ESR < 1.5 Ω
Output Voltage	All	0		20	V	
Output Current	All	0		80	A	Output voltage dependent
INPUT CHARACTERISTICS						
Input Under-Voltage Lockout						
Turn-On Voltage Threshold	All	9.2	9.5	10	V	
Turn-Off Voltage Threshold	All	8.1	8.5	8.9	V	
Lockout Hysteresis	All		1.0		V	
Input Current Limit	All				A	
No-Load Input Current	5				mA	
"	12				mA	
"	20				mA	
Disabled Input Current	All				mA	
Input Filter Components Value (C\L\C)	All		400.1120		µF\µH\µF	
OUTPUT CHARACTERISTICS						
Output Voltage Range	All	0		20	V	Set output by Rtrim resistor
Operating Output Current Range	All	0		80	A	
Output Voltage Regulation						
Total Output Voltage Range	All		±160 mV ±4%*Vout			Sense pin, over sample, line, load, temp. & life
Output Voltage Ripple and Noise (pk-pk/36Vin)	5				mV	12 Vin Full Load; 100uF; 20 MHz b.w.
"	12				mV	"
"	20				mV	"
Output DC Over Current limit	All		96		A	Effective on input, output condition
External Output Capacitance	All	0		5000	µF	ESR > 1 mΩ
F Option: Isense voltage						
No load	All				V	
Full load	All				V	80 A load
Output resistance of Isense	All				kΩ	
F Option: Itrim voltage						
Voltage at no load	All		0.12		V	
Voltage at maximum load	All		2.12		V	80 A load
Pull-Up Resistance of Itrim Pin	All		10.2		kΩ	
Pull-Up Voltage	All		2.5		V	
F Option: Reverse Current	All				µA	Enabled or Disabled
EFFICIENCY						
100% Load; 20 Vin	5				%	
" ; 20 Vin	12				%	
" ; 12 Vin	20				%	W mode only
50% Load; 20 Vin	5				%	
" ; 20 Vin	12				%	
" ; 12 Vin	20				%	W mode only

NQ20x20HGx80 Electrical Characteristics (continued)

Ta = 25 °C, airflow rate = 300 LFM, Vin = 12 V dc unless otherwise noted; full operating temperature range is -40 °C to +105 °C ambient temperature with appropriate power derating. Specifications subject to change without notice.

Parameter	Vout	Min.	Typ.	Max.	Units	Notes & Conditions
DYNAMIC CHARACTERISTICS						
Output Voltage during Current Transient						
For a Step Change in Output Current	All				V	(0.1 A/μs); 50%-75%-50% Iout max
Settling Time	All				ms	To within 1.5% Vout nom.
Turn on Transient						
Startup delay	All				ms	Resistive load
Rise Rate	All				V/ms	"
Output Voltage Overshoot	All				V	"
FEATURE CHARACTERISTICS						
Switching Frequency	All	240	250	260	kHz	
ON/OFF Control						
Negative Logic (N) ON/OFF Control						
Off-State Voltage	All	1.8		3.3	V	
On-State Voltage	All	0		0.8	V	
Pull-Up Voltage	All		3.3		V	
Pull-Up Resistance	All		10		kΩ	
Output Voltage Trim Range	All	0		20	V	Measured Vout+ to common pins
Input/Output Over-Voltage Protection	All	22	24	25	V	Over full temp range
Over-Temperature Shutdown	All		115		°C	Average PCB Temperature
Over-Temperature Shutdown Restart Hysteresis	All		15		°C	
RELIABILITY CHARACTERISTICS						
Calculated MTBF (TR-NWT-000332; Telcordia)	All		TBD		10 ⁶ Hrs.	100% load, 200LFM, 40 °C Ta
Calculated MTBF (MIL-HDBK-217F; MIL-217)	All		TBD		10 ⁶ Hrs.	100% load, 200LFM, 40 °C Ta
Field Demonstrated MTBF	All				10 ⁶ Hrs.	See our website for details
TEMP LIMITS FOR POWER DERATING						
Semiconductor Junction Temperature	All			125	°C	Package rated to 150 °C
Board Temperature	All			125	°C	ULrated max operating temp 130 °C
Baseplate Temperature	All			100	°C	



Technical Specification

Input: 9-20 V
Outputs: 0-20V
Current: 80A
Package: Half-brick

Parameter	Notes & Conditions
STANDARDS COMPLIANCE	Pending
EN60950-1:2006 / A11:2009 / A1:2010	
UL 60950-1:2007	
CAN/CSA-C22.2 No. 60950-1:2003	

Note: An external input fuse must always be used to meet these safety requirements. Contact SynQor for official safety certificates on new releases or download from the SynQor website.

Parameter	# Units	Test Conditions
QUALIFICATION TESTING		
Life Test	32	95% rated V_{in} and load, units at derating point, 1000 hours
Vibration	5	10-55 Hz sweep, 0.060" total excursion, 1 min./sweep, 120 sweeps for 3 axis
Mechanical Shock	5	100g minimum, 2 drops in x, y and z axis
Temperature Cycling	10	-40 °C to 100 °C, unit temp. ramp 15 °C/min., 500 cycles
Power/Thermal Cycling	5	$T_{operating}$ = min to max, V_{in} = min to max, full load, 100 cycles
Design Marginality	5	T_{min} -10 °C to T_{max} +10 °C, 5 °C steps, V_{in} = min to max, 0-105% load
Humidity	5	85 °C, 85% RH, 1000 hours, continuous V_{in} applied except 5 min/day
Solderability	15 pins	MIL-STD-883, method 2003
Altitude	2	70,000 feet (21 km), see Note

Note: A conductive cooling design is generally needed for high altitude applications because of naturally poor convective cooling at rare atmospheres.



Ordering Information

Input: 9-20 V
Outputs: 0-20V
Current: 80A
Package: Half-brick

PART NUMBERING SYSTEM

The part numbering system for SynQor's dc-dc converters follows the format shown in the example below.

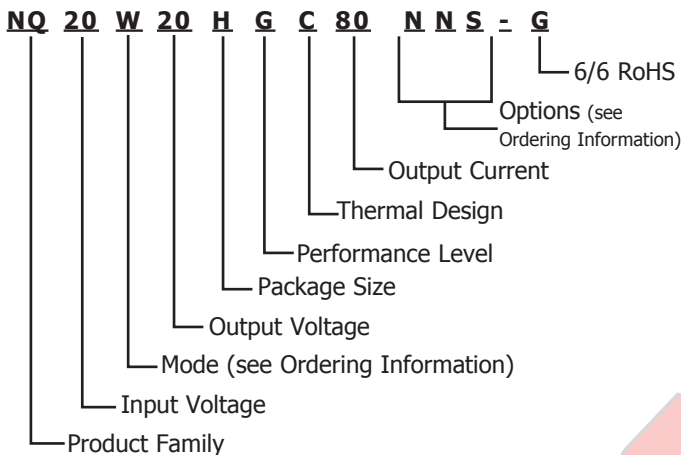

The first 12 characters comprise the base part number and the last 3 characters indicate available options. The "-G" suffix indicates 6/6 RoHS compliance.

Application Notes

A variety of application notes and technical white papers can be downloaded in pdf format from our website.

RoHS Compliance: The EU led RoHS (Restriction of Hazardous Substances) Directive bans the use of Lead, Cadmium, Hexavalent Chromium, Mercury, Polybrominated Biphenyls (PBB), and Polybrominated Diphenyl Ether (PBDE) in Electrical and Electronic Equipment. This SynQor product is 6/6 RoHS compliant. For more information please refer to SynQor's RoHS addendum available at our [RoHS Compliance / Lead Free Initiative web page](#) or e-mail us at rohs@synqor.com.

ORDERING INFORMATION

The tables below show the valid model numbers and ordering options for converters in this product family. When ordering SynQor converters, please ensure that you use the complete 15 character part number consisting of the 12 character base part number and the additional 3 characters for options. Add "-G" to the model number for 6/6 RoHS compliance.

Model Number	Input Voltage	Output Voltage	Max Output Current
NQ20w20xNyz-G	9-20 V	0-20V	80A

The following options must be included in place of the **wxyz** spaces in the model numbers listed above.

Mode: w	Options Description: x y z			
	Thermal Design	Enable Logic	Pin Style	Feature Set
T - Buck W - Buck / Boost	C - Encased with Threaded Baseplate D - Encased with Non-Threaded Baseplate V - Encased with Flanged Baseplate	N - Negative	K - 0.110" N - 0.145" R - 0.180" Y - 0.250"	S - Standard F - Current Sharing / Trimmable current limit

Not all combinations make valid part numbers, please contact SynQor for availability. See the [Product Summary web page](#) for more options.

PATENTS

SynQor holds the following U.S. patents, one or more of which apply to each product listed in this document. Additional patent applications may be pending or filed in the future.

5,999,417	6,222,742	6,545,890	6,577,109	6,594,159
6,731,520	6,894,468	6,896,526	6,927,987	7,050,309
7,072,190	7,085,146	7,119,524	7,269,034	7,272,021
7,272,023	7,558,083	7,564,702	7,765,687	7,787,261

Contact SynQor for further information:

Phone: 978-849-0600
Toll Free: 1-888-567-9596
Fax: 978-849-0602
E-mail: power@synqor.com
Web: www.synqor.com
Address: 155 Swanson Road
 Boxborough, MA 01719
 USA

Warranty

SynQor offers a three (3) year limited warranty. Complete warranty information is listed on our website or is available upon request from SynQor.

Information furnished by SynQor is believed to be accurate and reliable. However, no responsibility is assumed by SynQor for its use, nor for any infringements of patents or other rights of third parties which may result from its use. No license is granted by implication or otherwise under any patent or patent rights of SynQor.