

High Gain Darlington Output Optocouplers

Technical Data

4N45 4N46

Features

- **High Current Transfer Ratio—1500% Typical**
- **Low Input Current Requirement—0.5 mA**
- **Performance Guaranteed over 0°C to 70°C Temperature Range**
- **Internal Base-Emitter Resistor Minimizes Output Leakage**
- **Gain-Bandwidth Adjustment Pin**
- **Safety Approval**
UL Recognized -2500 V rms for 1 Minute
CSA Approved

Applications

- **Telephone Ring Detector**
- **Digital Logic Ground Isolation**
- **Low Input Current Line Receiver**
- **Line Voltage Status Indicator—Low Input Power Dissipation**
- **Logic to Reed Relay Interface**
- **Level Shifting**
- **Interface Between Logic Families**

Description

The 4N45/46 optocouplers contain a GaAsP light emitting diode optically coupled to a high gain photodetector IC.

The excellent performance over temperature results from the inclusion of an integrated emitter-base bypass resistor which shunts photodiode and first stage leakage currents as well as bleeding off excess base drive to ground. External access to the second stage base provides the capability for better noise rejection than a conventional photodarlington detector. An external resistor or capacitor at the base can be added to make a gain-bandwidth or input current threshold adjustment. The base lead can also be used for feedback.

Functional Diagram

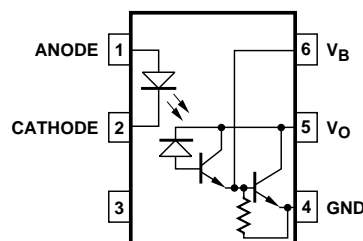

The high current transfer ratio at very low input currents permits circuit designs in which adequate margin can be allowed for the effects of optical coupling variations.

The 4N46 has a 350% minimum CTR at an input current of only 0.5 mA making it ideal for use in low input current applications such as MOS, CMOS and low power logic interfacing. Compatibility with high voltage CMOS logic systems is assured by the 20 V minimum breakdown voltage of the output transistor and by the guaranteed maximum output leakage (I_{OH}) at 18 V.

The 4N45 has a 250% minimum CTR at 1.0 mA input current and a 7 V minimum breakdown voltage rating.

Selection for lower input current down to 250 μ A is available upon request.

TRUTH TABLE
(POSITIVE LOGIC)

| LED | OUTPUT |
|-----|--------|
| ON | L |
| OFF | H |

*JEDEC Registered Data
**JEDEC Registered up to 70°C.

CAUTION: It is advised that normal static precautions be taken in handling and assembly of this component to prevent damage and/or degradation which may be induced by ESD.

Ordering Information

Specify part number followed by Option Number (if desired).

4N45#XXX

- 300 = Gull Wing Surface Mount Lead Option
- 500 = Tape/Reel Package Option (1 K min)

Option data sheets available. Contact your Hewlett-Packard sales representative or authorized distributor for information.

Schematic

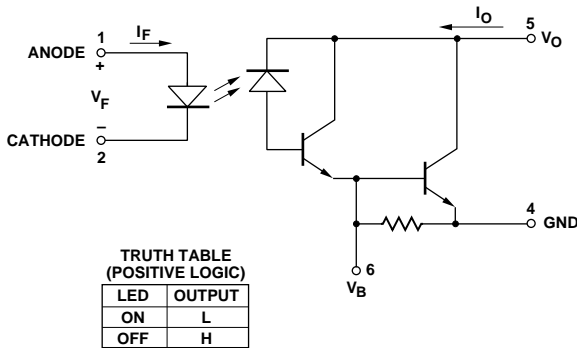

Outline Drawing

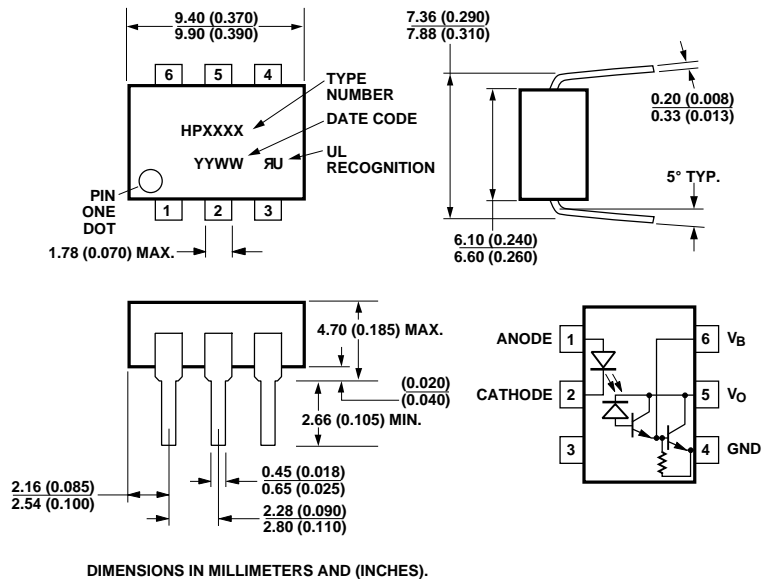

Outline Drawing – Option 300

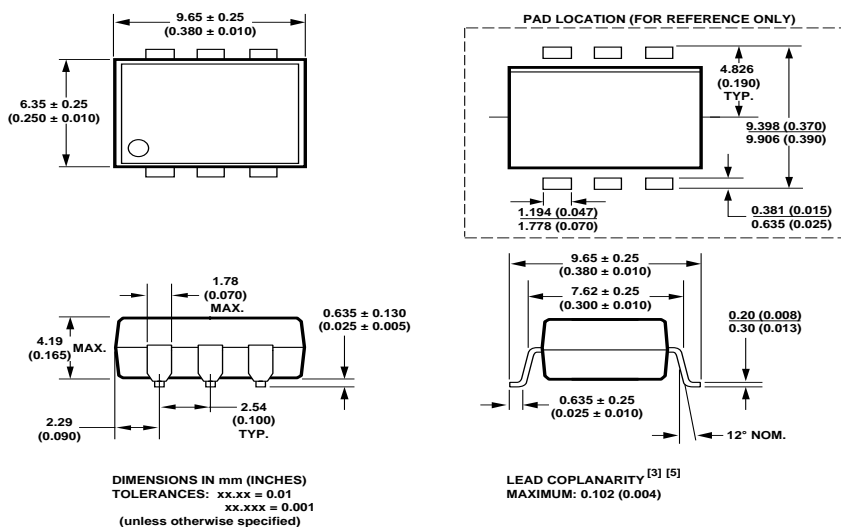

Thermal Profile (Option #300)

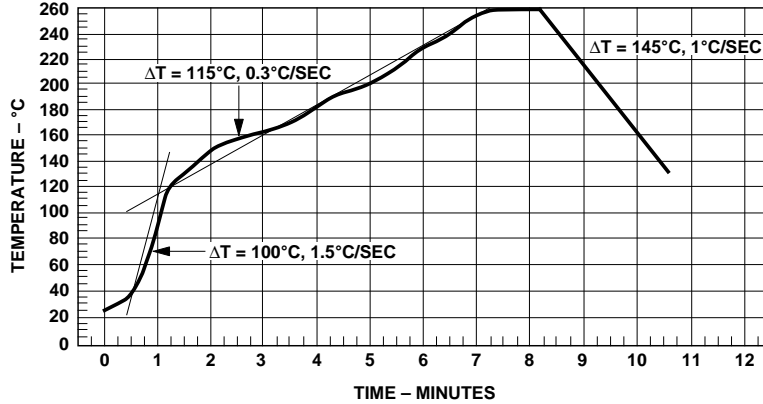

Figure 1. Maximum Solder Reflow Thermal Profile.
(Note: Use of non-chlorine activated fluxes is recommended.)

Regulatory Information

The 4N45 and 4N46 have been approved by the following regulatory organizations:

UL

Recognized under UL 1577, Component Recognition Program, File E55361.

CSA

Approved under CSA Component Acceptance Notice #5, File CA 88324.

Insulation and Safety Related Specifications

| Parameter | Symbol | Value | Units | Conditions |
|--|--------|-------|-------|---|
| Min. External Air Gap (External Clearance) | L(IO1) | 7.1 | mm | Measured from input terminals to output terminals, shortest distance through air |
| Min. External Tracking Path (External Creepage) | L(IO2) | 7.4 | mm | Measured from input terminals to output terminals, shortest distance path along body |
| Min. Internal Plastic Gap (Internal Clearance) | | 0.08 | mm | Through insulation distance, conductor to conductor, usually the direct distance between the photoemitter and photodetector inside the optocoupler cavity |
| Tracking Resistance (Comparative Tracking Index) | CTI | 200 | Volts | DIN IEC 112/VDE 0303 PART 1 |
| Isolation Group | | IIIa | | Material Group (DIN VDE 0110, 1/89, Table 1) |

Option 300 – surface mount classification is Class A in accordance with CECC 00802.

Absolute Maximum Ratings

| | |
|--|---|
| Storage Temperature, T_S | -55°C to +125°C |
| Operating Temperature, T_A | -40°C to +85°C |
| Lead Solder Temperature, max | 260°C for 10 s (1.6 mm below seating plane) |
| Average Input Current, I_F | 20 mA ^[1] |
| Peak Input Current, I_F | 40 mA (50% duty cycle, 1 ms pulse width) |
| Peak Transient Input Current, I_F | 1.0 A ($\leq 1 \mu\text{s}$ pulse width, 300 pps) |
| Reverse Input Voltage, V_R | 5 V |
| Input Power Dissipation, P_I | 35 mW ^[2] |
| Output Current, I_O (Pin 5) | 60 mA ^[3] |
| Emitter-Base Reverse Voltage (Pins 4-6) | 0.5 V |
| Output Voltage, V_O (Pin 5-4) | |
| 4N45 | -0.5 to 7 V |
| 4N46 | -0.5 to 20 V |
| Output Power Dissipation | 100 mW ^[4] |
| Infrared and Vapor Phase Reflow Temperature (Option #300) | see Fig. 1, Thermal Profile |

Recommended Operating Conditions

| Parameter | Symbol | Min. | Max. | Units |
|-----------------------|--------------|------|------|-------|
| Output Voltage (4N46) | V_O | 4.5 | 20 | V |
| Output Voltage (4N45) | | 4.5 | 7 | V |
| Input Current (High) | $I_{F(ON)}$ | 0.5 | 10 | mA |
| Input Voltage (Low) | $V_{F(OFF)}$ | 0 | 0.8 | V |
| Operating Temperature | T_A | 0 | 70 | °C |

DC Electrical Specifications

Over recommended temperature ($T_A = 0^\circ\text{C}$ to 70°C), unless otherwise specified.

| Parameter | Device | Symbol | Min. | Typ.* | Max. | Units | Test Conditions | Fig. | Note |
|--|--------|---------------------------------|------|-------|------|---------------|---|-----------------|---------|
| Current Transfer Ratio | 4N46 | CTR | 350* | 1500 | 3200 | % | $I_F = 0.5\text{ mA}, V_O = 1.0\text{ V}$ | 3, 4, 5, 11, 12 | 5, 6, 8 |
| | | | 500* | 1500 | 2000 | | $I_F = 1.0\text{ mA}, V_O = 1.0\text{ V}$ | | |
| | | | 200* | 600 | 1000 | | $I_F = 10\text{ mA}, V_O = 1.2\text{ V}$ | | |
| | 4N45 | | 250* | 1200 | 2000 | % | $I_F = 1.0\text{ mA}, V_O = 1.0\text{ V}$ | | |
| | | | 200* | 500 | 1000 | | $I_F = 10\text{ mA}, V_O = 1.2\text{ V}$ | | |
| Logic Low Output Voltage | 4N46 | V_{OL} | | 0.90 | 1.0 | V | $I_F = 0.5\text{ mA}, I_{OL} = 1.75\text{ mA}$ | 3 | 6 |
| | | | | 0.92 | 1.0 | | $I_F = 1.0\text{ mA}, I_{OL} = 5.0\text{ mA}$ | | |
| | | | | 0.95 | 1.2 | | $I_F = 10\text{ mA}, I_{OL} = 20\text{ mA}$ | | |
| | 4N45 | | | 0.90 | 1.0 | V | $I_F = 1.0\text{ mA}, I_{OL} = 2.5\text{ mA}$ | | |
| | | | | 0.95 | 1.2 | | $I_F = 10\text{ mA}, I_{OL} = 20\text{ mA}$ | | |
| Logic High Output Current | 4N46 | I_{OH}^* | | 0.001 | 100 | μA | $I_F = 0\text{ mA}, V_O = 18\text{ V}$ | | 6 |
| | 4N45 | | | 0.001 | 250 | μA | $I_F = 0\text{ mA}, V_O = 5\text{ V}$ | | |
| Input Forward Voltage | | V_F | | 1.4 | 1.7* | V | $T_A = 25^\circ\text{C}$ $I_F = 1.0\text{ mA}$ | 2 | |
| | | | | | 1.75 | | | | |
| Temperature Coefficient of Forward Voltage | | $\frac{\Delta V_F}{\Delta T_A}$ | | -1.8 | | mV/°C | $I_F = 1.0\text{ mA}$ | | |
| Input Reverse Breakdown Voltage | | BV_R^* | 5 | | | V | $I_R = 10\text{ }\mu\text{A}$ | | |
| Input Capacitance | | C_{IN} | | 60 | | pF | $f = 1\text{ MHz}, V_F = 0$ | | |

Switching Specifications

(Over recommended temperature $T_A = 0^\circ\text{C}$ to 70°C unless otherwise specified. $V_{CC} = 5.0\text{ V}$.)

| Parameter | Symbol | Min. | Typ.* | Max. | Units | Test Conditions | Fig. | Note |
|---|-----------|------|-------|------|------------------|--|--------------------|------|
| Propagation Delay Time to Logic Low at Output | t_{PHL} | | 80 | | μs | $T_A = 25^\circ\text{C}$ $I_F = 0.5\text{ mA}$ $R_L = 10\text{ k}\Omega$ | 6, 7, 8, 9, 11, 13 | 6, 8 |
| | | | 5 | 50* | | $T_A = 25^\circ\text{C}$ $I_F = 10\text{ mA}$ $R_L = 2.2\text{ k}\Omega$ | | |
| | | | | 60 | | | | |
| Propagation Delay Time to Logic High at Output | t_{PLH} | | 1500 | | μs | $T_A = 25^\circ\text{C}$ $I_F = 10\text{ mA}$ $R_L = 10\text{ k}\Omega$ | 6, 7, 8, 9, 11, 13 | 6, 8 |
| | | | 150 | 500* | | $T_A = 25^\circ\text{C}$ $I_F = 10\text{ mA}$ $R_L = 220\text{ k}\Omega$ | | |
| | | | | 600 | | | | |
| Common Mode Transient Immunity at High Output Level | $ CM_H $ | | 500 | | V/ μs | $I_F = 0\text{ mA}, R_L = 10\text{ k}\Omega$ $ V_{CM} = 10\text{ V}_{P-P}$ | 10 | 9 |
| Common Mode Transient Immunity at Low Output Level | $ CM_L $ | | 500 | | V/ μs | $I_F = 1.0\text{ mA}, R_L = 10\text{ k}\Omega$ $ V_{CM} = 10\text{ V}_{P-P}$ | 10 | 9 |

*JEDEC Registered Data.

**All typicals at $T_A = 25^\circ\text{C}$, unless otherwise noted.

Package Characteristics

For $0^{\circ}\text{C} \leq T_A \leq 70^{\circ}\text{C}$, unless otherwise specified. All typicals at $T_A = 25^{\circ}\text{C}$.

| Parameter | Symbol | Min. | Typ. | Max. | Units | Test Conditions | Fig. | Notes |
|---|-----------|------|-----------|------|----------|--|------|-------|
| Input-Output Momentary Withstand Voltage* | V_{ISO} | 2500 | | | V rms | $RH \leq 50\%$, $t = 1 \text{ min}$, $T_A = 25^{\circ}\text{C}$ | | 7, 10 |
| Resistance, Input-Output | R_{I-O} | | 10^{12} | | Ω | $V_{I-O} = 500 \text{ Vdc}$ | | 7 |
| Capacitance, Input-Output | C_{I-O} | | 0.6 | | pF | $f = 1 \text{ MHz}$ | | 7 |

*The Input-Output Momentary Withstand Voltage is a dielectric voltage rating that should not be interpreted as an input-output continuous voltage rating. For the continuous voltage rating refer to the VDE 0884 Insulation Characteristics Table (if applicable), your equipment level safety specification, or HP Application Note 1074, "Optocoupler Input-Output Endurance Voltage."

Notes:

- Derate linearly above 50°C free-air temperature at a rate of $0.4 \text{ mA}/^{\circ}\text{C}$.
- Derate linearly above 50°C free-air temperature at a rate of $0.7 \text{ mW}/^{\circ}\text{C}$.
- Derate linearly above 25°C free-air temperature at a rate of $0.8 \text{ mA}/^{\circ}\text{C}$.
- Derate linearly above 25°C free-air temperature at a rate of $1.5 \text{ mW}/^{\circ}\text{C}$.
- DC CURRENT TRANSFER RATIO is defined as the ratio of output collector current, I_O , to the forward LED input current, I_F , times 100%.
- Pin 6 Open.
- Device considered a two-terminal device: Pins 1, 2, 3 shorted together and Pins 4, 5, and 6 shorted together.
- Use of a resistor between pin 4 and 6 will decrease gain and delay time. (See Figures 11, 12, and 13.)
- Common mode transient immunity in Logic High level is the maximum tolerable (positive) dV_{cm}/dt on the leading edge of the common mode pulse, V_{CM} , to assure that the output will remain in a Logic High state (i.e., $V_O > 2.5 \text{ V}$). Common mode transient immunity in Logic Low level is the maximum tolerable (negative) dV_{cm}/dt on the trailing edge of the common mode pulse signal, V_{cm} , to assure that the output will remain in a Logic Low state (i.e., $V_O < 2.5 \text{ V}$).
- In accordance with UL 1577, each optocoupler is proof tested by applying an insulation test voltage $\geq 3000 \text{ V rms}$ for 1 second (leakage detection current limit, $I_{L-O} \leq 5 \mu\text{A}$).

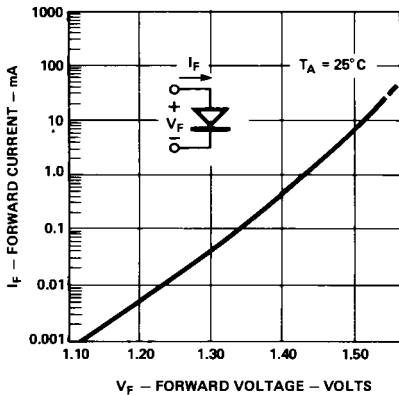

Figure 2. Input Diode Forward Current vs. Forward Voltage.

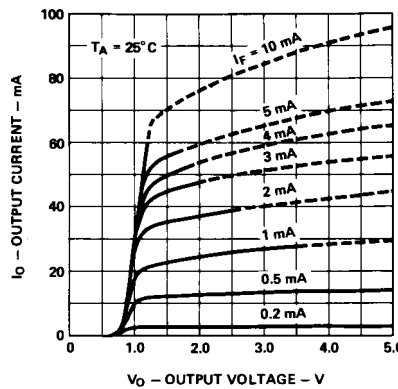

Figure 3. Typical DC Transfer Characteristics.

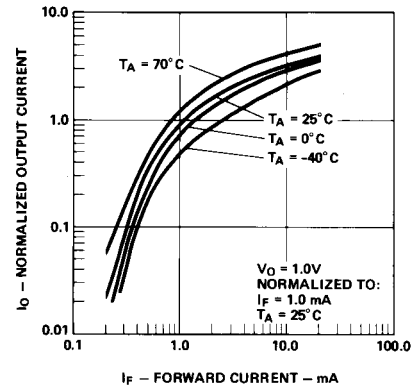

Figure 4. Output Current vs. Input Current.

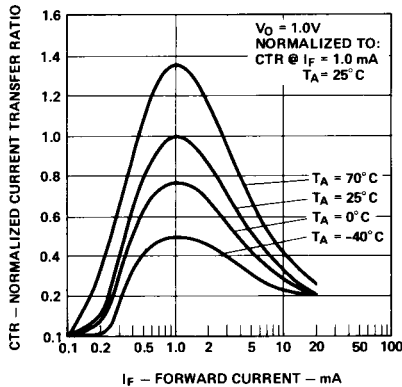

Figure 5. Current Transfer Ratio vs. Input Current.

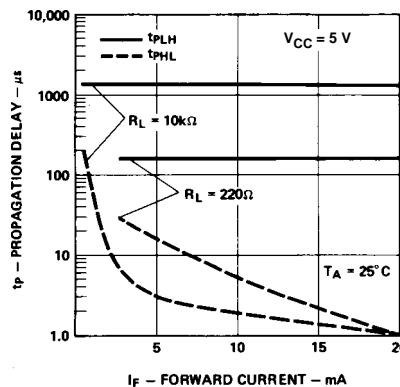

Figure 6. Propagation Delay vs. Forward Current.

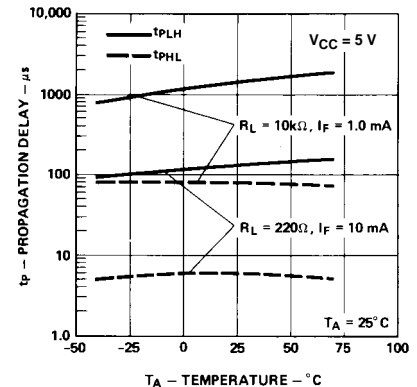

Figure 7. Propagation Delay vs. Temperature.

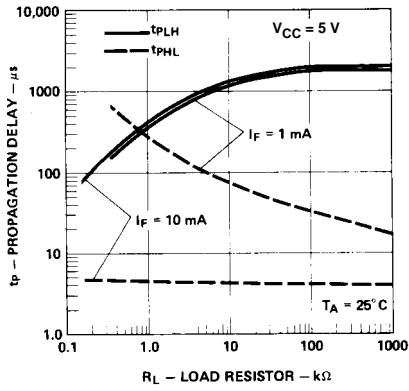

Figure 8. Propagation Delay vs. Load Resistor.

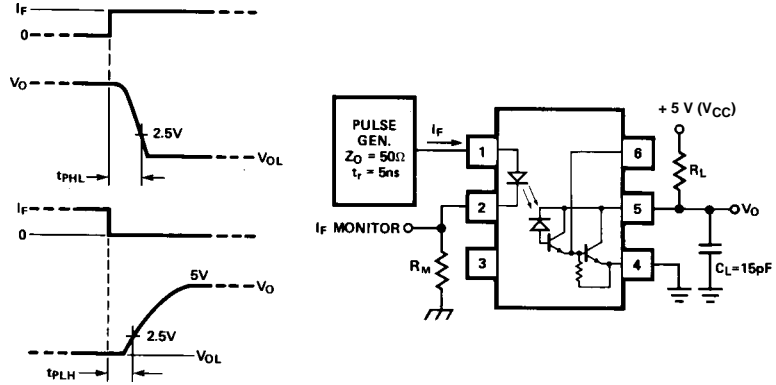

Figure 9. Switching Test Circuit.

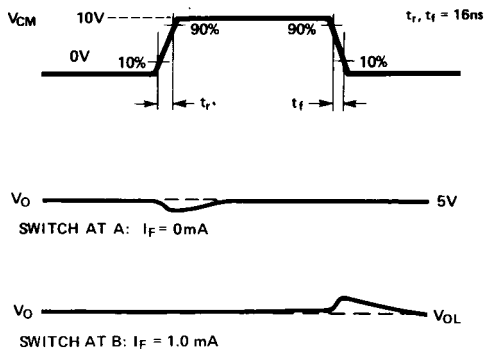

Figure 10. Test Circuit for Transient Immunity and Typical Waveforms.

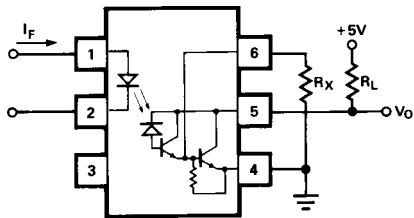

Figure 11. External Base Resistor, R_X .

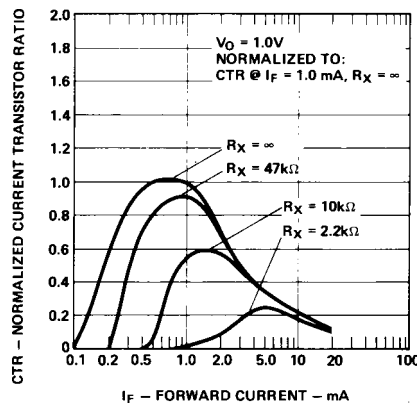

Figure 12. Effect of R_X On Current Transfer Ratio.

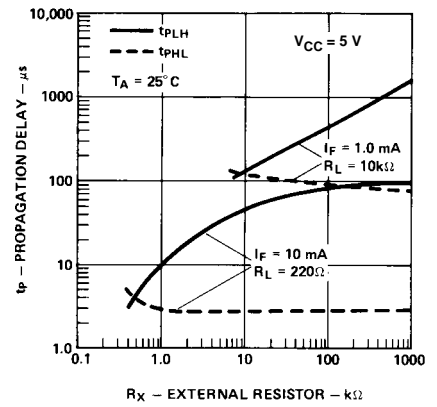
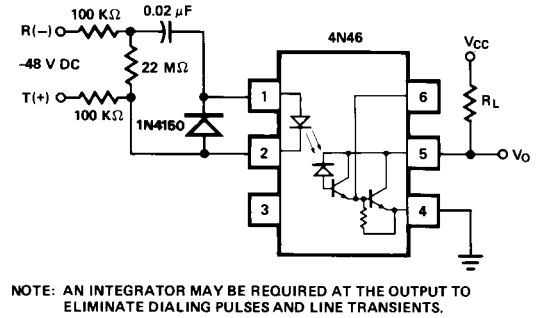
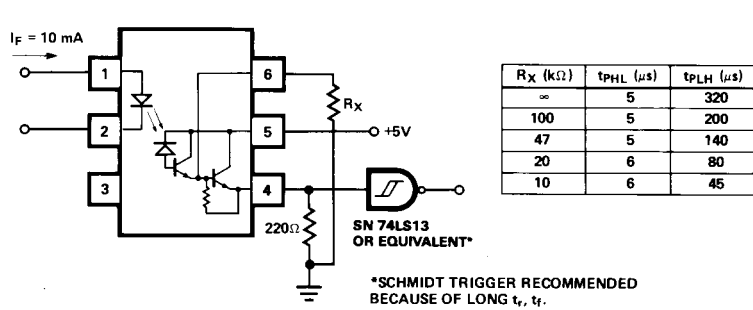
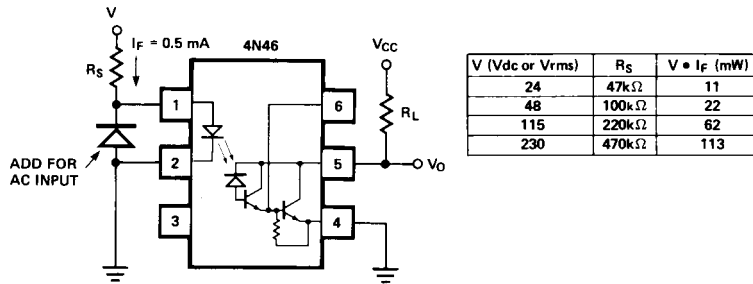

Figure 13. Effect of R_X On Propagation Delay.

Applications



TTL Interface



Telephone Ring Detector

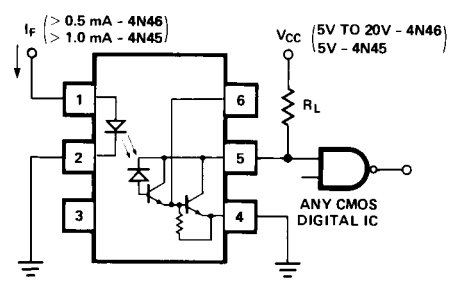

Line Voltage Monitor

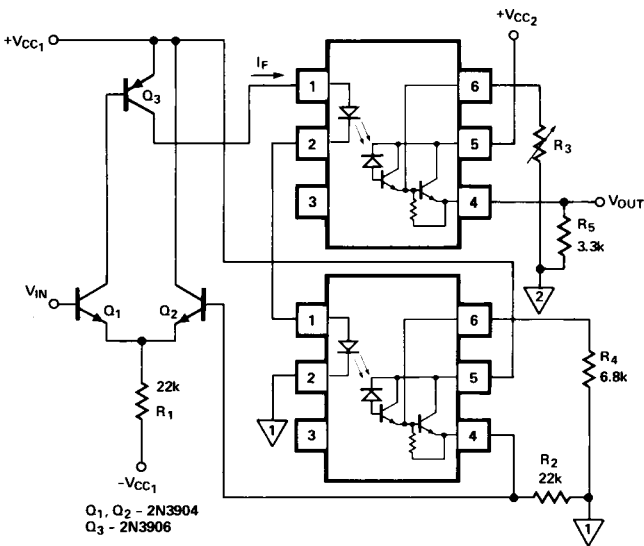

CMOS Interface

CHARACTERISTICS

$R_{IN} \approx 30M\Omega$, $R_{OUT} \approx 50\Omega$
 $V_{IN(MAX)} = V_{CC1} - 1V$, LINEARITY BETTER THAN 5%

DESIGN COMMENTS

R_1 - NOT CRITICAL ($\ll \frac{V_{IN(MAX)} - (-V_{CC1}) - V_{BE}}{I_F(MAX)}$) $h_{FE} Q_3$

R_2 - NOT CRITICAL (OMIT IF 0.2 TO 0.3V OFFSET IS TOLERABLE)

$R_4 > \frac{V_{IN(MAX)} + V_{BE}}{1 mA}$

$R_5 > \frac{V_{IN(MAX)}}{2.5 mA}$

NOTE: ADJUST R_3 SO $V_{OUT} = V_{IN}$ AT $V_{IN} = \frac{V_{IN(MAX)}}{2}$

Analog Signal Isolation