

New Jersey Semiconductor Products, Inc.

20 STERN AVE.
 SPRINGFIELD, NEW JERSEY 07081
 U.S.A.

2N2904/2N2905
2N2906/2N2907

TELEPHONE: (973) 376-2922
 (212) 227-6005
 FAX: (973) 376-8960

GENERAL PURPOSE AMPLIFIERS AND SWITCHES

DESCRIPTION

The 2N2904, 2N2905, 2N2906 and 2N2907 are silicon planar epitaxial PNP transistors in Jedec TO-39 (for 2N2904, 2N2905) and in Jedec TO-18 (for 2N2906 and 2N2907) metal cases. They are designed for high-speed saturated switching and general purpose applications.

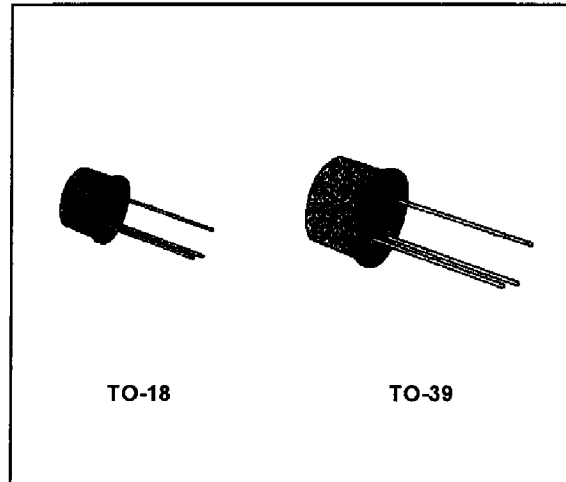
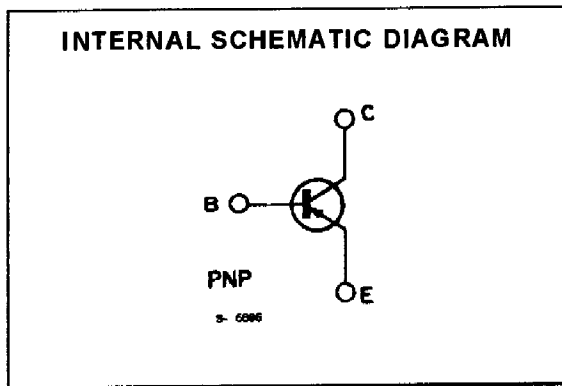

ABSOLUTE MAXIMUM RATINGS

Symbol	Parameter	Value	Unit
V_{CBO}	Collector-base Voltage ($I_E = 0$)	- 60	V
V_{CEO}	Collector-emitter Voltage ($I_B = 0$)	- 40	V
V_{EBO}	Emitter-base Voltage ($I_C = 0$)	- 5	V
I_C	Collector Current	- 600	mA
P_{tot}	Total Power Dissipation at $T_{amb} \leq 25^\circ C$		
	for 2N2904 and 2N2905	0.6	W
	for 2N2906 and 2N2907	0.4	W
	at $T_{case} \leq 25^\circ C$		
	for 2N2904 and 2N2905	3	W
	for 2N2906 and 2N2907	1.8	W
T_{stg}, T_J	Storage and Junction Temperature	- 65 to 200	$^\circ C$

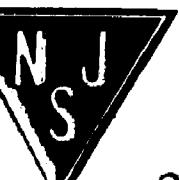

NJ Semi-Constructors reserves the right to change test conditions, parameters limits and package dimensions without notice information furnished by NJ Semi-Constructors is believed to be both accurate and reliable at the time of going to press. However NJ Semi-Constructors assumes no responsibility for any errors or omissions discovered in its use. NJ Semi-Constructors encourages customers to verify that datasheets are current before placing orders.

THERMAL DATA

			2N2904 2N2905	2N2906 2N2907
R _{th j-case}	Thermal Resistance Junction-case	Max	58.3 °C/W	97.3 °C/W
R _{th j-amb}	Thermal Resistance Junction-ambient	Max	292 °C/W	437.5 °C/W

ELECTRICAL CHARACTERISTICS (T_{amb} = 25 °C unless otherwise specified)

Symbol	Parameter	Test Conditions	Min.	Typ.	Max.	Unit
I _{CBO}	Collector Cutoff Current (I _E = 0)	V _{CB} = - 50 V V _{CB} = - 50 V T _{amb} = 150 °C			- 20 - 20	nA μA
I _{CEX}	Collector Cutoff Current (V _{BE} = 0.5 V)	V _{CE} = - 30 V			- 50	nA
I _{BEX}	Base Cutoff Current (V _{BE} = 0.5 V)	V _{CE} = - 30 V			- 50	nA
V _{(BR) CBO}	Collector-base Breakdown Voltage (I _E = 0)	I _C = - 10 μA	- 60			V
V _{(BR) CEO} *	Collector-emitter Breakdown Voltage (I _B = 0)	I _C = - 10 mA	- 40			V
V _{(BR) EBO}	Emitter-base Breakdown Voltage (I _C = 0)	I _E = - 10 μA	- 5			V
V _{CE (sat)} *	Collector-emitter Saturation Voltage	I _C = - 150 mA I _B = - 15 mA I _C = - 500 mA I _B = - 50 mA			- 0.4 - 1.6	V V
V _{BE (sat)} *	Base-emitter Saturation Voltage	I _C = - 150 mA I _B = - 16 mA I _C = - 500 mA I _B = - 50 mA			- 1.3 - 2.6	V V
h _{FE} *	DC Current Gain	for 2N2904 and 2N2906 I _C = - 0.1 mA V _{CE} = - 10 V I _C = - 1 mA V _{CE} = - 10 V I _C = - 10 mA V _{CE} = - 10 V I _C = - 150 mA V _{CE} = - 10 V I _C = - 500 mA V _{CE} = - 10 V	20 25 35 40 20		120	
h _{FE} *	DC Current Gain	for 2N2905 and 2N2907 I _C = - 0.1 mA V _{CE} = - 10 V I _C = - 1 mA V _{CE} = - 10 V I _C = - 10 mA V _{CE} = - 10 V I _C = - 150 mA V _{CE} = - 10 V I _C = - 500 mA V _{CE} = - 10 V	35 50 75 100 30		300	
f _T	Transition Frequency	I _C = - 50 mA V _{CE} = - 20 V f = 100 MHz	200			MHz
C _{EBO}	Emitter-base Capacitance	I _C = 0 V _{EB} = - 2 V f = 1 MHz			30	pF
C _{CBO}	Collector-base Capacitance	I _E = 0 V _{CB} = - 10 V f = 1 MHz			8	pF
t _d	Delay Time	I _C = - 150 mA V _{CC} = - 30 V I _{B1} = - 15 mA			10	ns
t _r	Rise Time	I _C = - 150 mA V _{CC} = - 30 V I _{B1} = - 15 mA			40	ns
t _s	Storage Time	I _C = - 150 mA V _{CC} = - 6 V I _{B1} = - I _{B2} = - 15 mA			80	ns
t _f	Fall Time	I _C = - 150 mA V _{CC} = - 6 V I _{B1} = - I _{B2} = - 15 mA			30	ns

* Pulsed : pulse duration = 300 μs, duty cycle = 1 %.

TO-18 MECHANICAL DATA

DIM.	mm			inch		
	MIN.	TYP.	MAX.	MIN.	TYP.	MAX.
A		12.7			0.500	
B			0.49			0.019
D			5.3			0.208
E			4.9			0.193
F			5.8			0.228
G	2.54			0.100		
H			1.2			0.047
I			1.16			0.045
L	45°			45°		

