

Product Features:

Low Jitter, Non-PLL Based Output
 Available in Both Clipped Sinewave and HCMOS Output Levels
 Compatible with Leadfree Processing

Applications:

Server & Storage
 Sonet /SDH
 802.11 / Wifi
 T1/E1, T3/E3
 Fibre Channel

Frequency	8.000 Mhz to 30 Mhz
Output Level Clipped Sinewave HCMOS	0.8 V p-p Min. '0'=0.5 VDC Max., '1'=0.8Vcc Min.
Output Load Clipped Sinewave HCMOS	20K Ohms / 10 pF 15pF
Duty Cycle (HCMOS)	50% ±10%
Rise / Fall Time (HCMOS)	10 nS Max.
Frequency Stability Vs Temperature Vs Voltage Vs Load(5%)	See Frequency Stability Table ± 0.3 ppm Max. ±0.2 ppm Max.
Frequency Tolerance @ 25° C	± 1.0 ppm
Aging	± 1 ppm / Year Max.
Supply Voltage	See Supply Voltage Table , tolerance ± 5%
Current	2.0 mA Max. (Clipped Sinewave) 6.0 mA Max. (HCMOS)
Voltage Control (I733/I734)	1.5 VDC ± 1.0 VDC, ± 5.0 ppm Min.
Operating	See Operating Temperature Table
Storage	-40° C to +85° C
Phase Noise	-86 dBc/Hz @ 10 Hz -115 dBc/Hz @ 100 Hz -138 dBc/Hz @ 1KHz -146 dBc/Hz @ 10 Khz

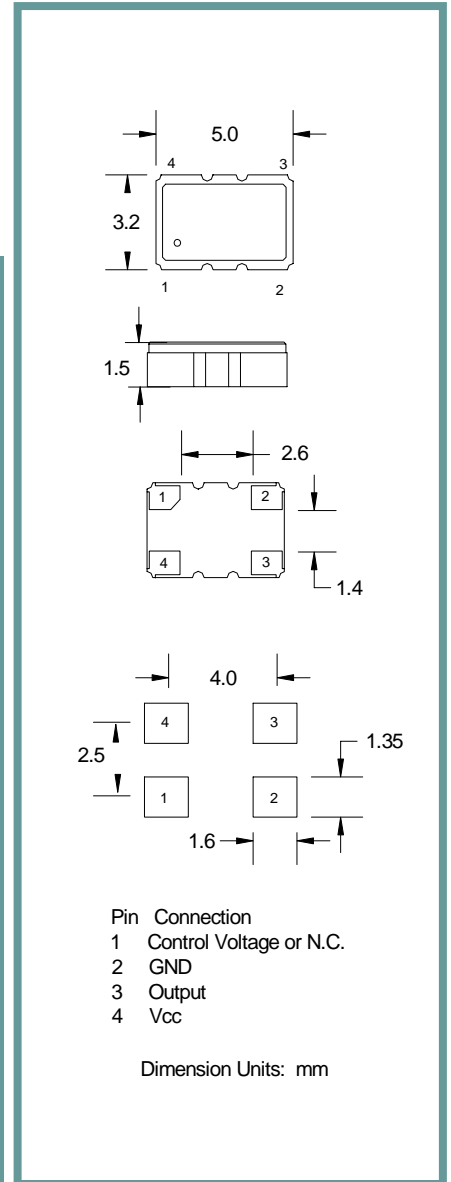

Part Number Guide		Sample Part Number: I537-1Q3-20.000 Mhz		
Package	Operating Temperature	Frequency Stability vs Temperature	Supply Voltage	Frequency
I533 (Clipped Sinewave TCXO)	7 = 0° C to +50° C	**N = ±1.0 ppm	3 = 3.3 V	- 20.000 MHz
I534 (HCMOS TCXO)	1 = 0° C to +70° C	**O = ±1.5 ppm	7 = 3.0 V	
I733 (Clipped Sinewave TCVCXO)	3 = -20° C to +70° C	**P = ±2.0 ppm	2 = 2.7 V	
I734 (HCMOS TCVCXO)	2 = -40° C to +85° C	Q = ±2.5 ppm		
		R = ±3.0 ppm		
		J = ±5.0 ppm		

NOTE: A 0.01 µF bypass capacitor is recommended between Vcc (pin 4) and GND (pin 2) to minimize power supply noise.
 ** Not available for all temperature ranges.



3.2 mm x 5 mm Ceramic Package SMD TCXO

I533/I534/I733/I734 Series

Pb Free Solder Reflow Profile:

Typical Application:

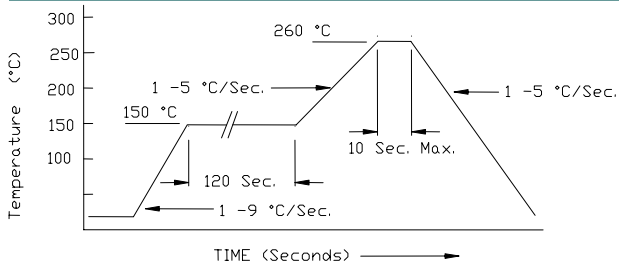

*Units are backward compatible with 240C reflow processes

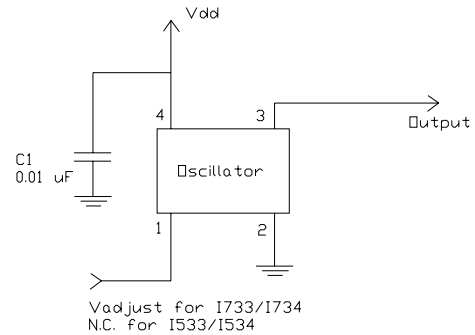

Package Information:

MSL = N.A. (package does not contain plastic, storage life is unlimited under normal room conditions).
Termination = e4 (Au over Ni over W base metalization).

Tape and Reel Information:

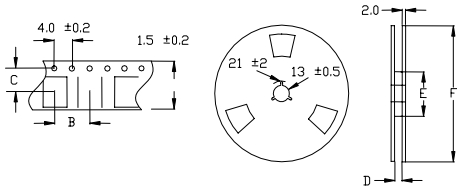

Quantity per Reel	1000
A	8 +/- .3
B	4 +/- .2
C	3.5 +/- .2
D	9 +/- 1 or 12 +/- 3
E	60 / 80
F	180

Environmental Specifications

Thermal Shock	MIL-STD-883, Method 1011, Condition A
Moisture Resistance	MIL-STD-883, Method 1004
Mechanical Shock	MIL-STD-883, Method 2002, Condition B
Mechanical Vibration	MIL-STD-883, Method 2007, Condition A
Resistance to Soldering Heat	J-STD-020C, Table 5-2 Pb-free devices (except 2 cycles max)
Hazardous Substance	Pb-Free / RoHS / Green Compliant
Solderability	JESD22-B102-D Method 2 (Preconditioning E)
Terminal Strength	MIL-STD-883, Method 2004, Test Condition D
Gross Leak	MIL-STD-883, Method 1014, Condition C
Fine Leak	MIL-STD-883, Method 1014, Condition A2, R1=2x10 ⁻⁸ atm cc/s
Solvent Resistance	MIL-STD-202, Method 215

Marking

Line 1: I - Date Code (YWW)
Line 2: Frequency