

Z80185/Z80195

SMART PERIPHERAL CONTROLLERS

FEATURES

Part	ROM (KB)	UART Baud Rate	Speed (MHz)
Z80185	32 x 8	512 Kbps	20, 33
Z80195	0	512 Kbps	20, 33

- 100-Pin QFP Package
- 5.0-Volt Operating Range
- Low-Power Consumption
- 0°C to +70°C Temperature Range

- Enhanced Z8S180 MPU
- Four Z80 CTC Channels
- One Channel ESCC™ Controller
- Two 8-Bit Parallel I/O Ports
- Bidirectional Centronics Interface (IEEE 1284)
- Low-EMI Option

GENERAL DESCRIPTION

The Z80185 and Z80195 are smart peripheral controller devices designed for general data communications applications, and architected specifically to accommodate all input and output (I/O) requirements for serial and parallel connectivity. Combining a high-performance CPU core with a variety of system and I/O resources, the Z80185/195 are useful in a broad range of applications. The Z80195 is the ROMless version of the device.

The Z80185 and Z80195 feature an enhanced Z8S180 microprocessor linked with one enhanced channel of the Z85230 ESCC™ serial communications controller, and 25 bits of parallel I/O, allowing software code compatibility with existing software code.

Seventeen lines can be configured as bidirectional Centronics (IEEE 1284) controllers. When configured as a 1284 controller, an I/O line can operate in either the host or peripheral role in compatible, nibble, byte or ECP mode. In addition, the Z80185 includes 32 Kbytes of on-chip ROM.

These devices are well-suited for external modems using a parallel interface, protocol translators, and cost-effective WAN adapters. The Z80185/195 is ideal for handling all laser printer I/O, as well as the main processor in cost-effective printer applications.

Notes:

All Signals with a preceding front slash, "/", are active Low.

Power connections follow conventional descriptions below:

Connection	Circuit	Device
Power	V_{CC}	V_{DD}
Ground	GND	V_{SS}

TIMING DIAGRAMS (Continued)

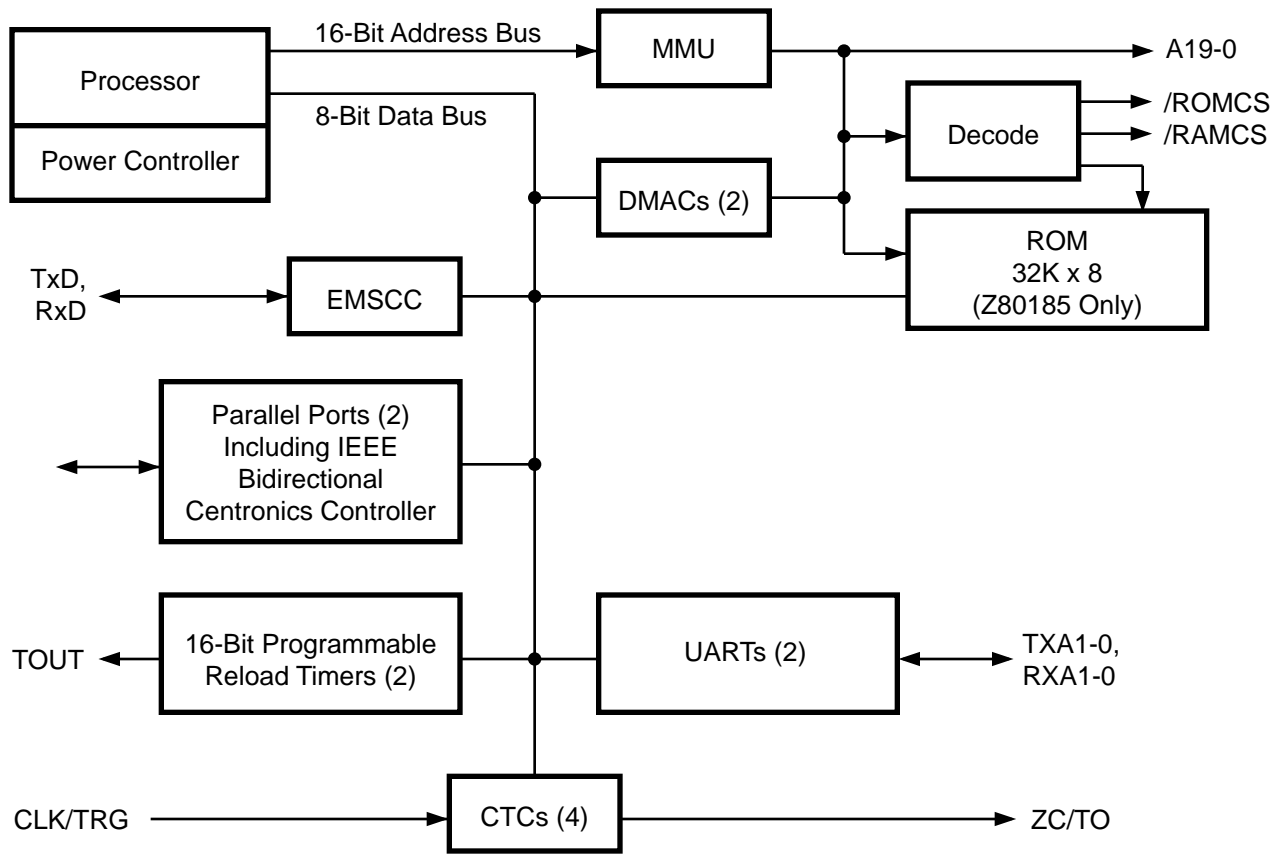

Figure 1. Z80185/195 Functional Block Diagram

PIN DESCRIPTION

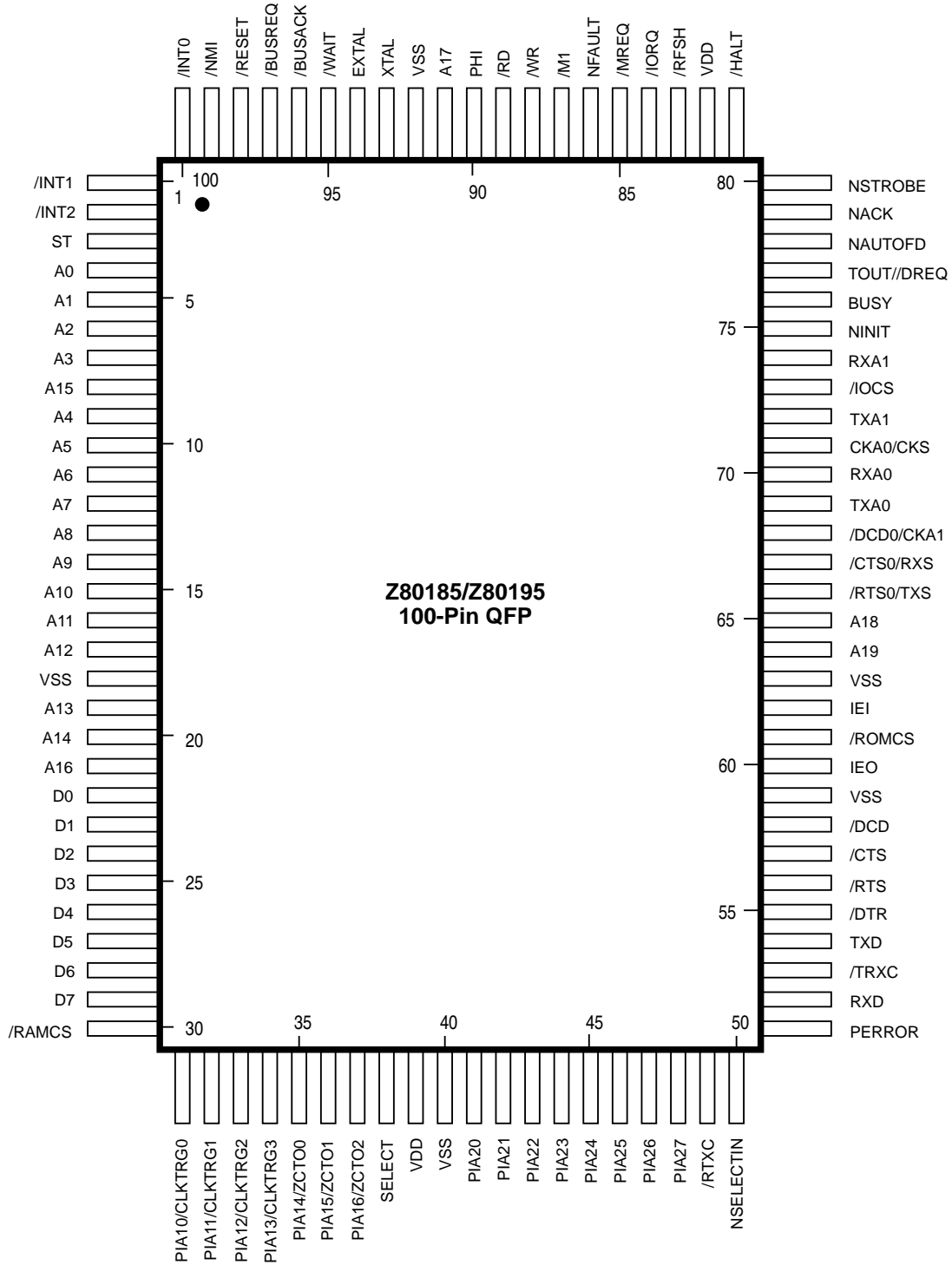

Figure 2. 100-Pin QFP Pin Assignments

ABSOLUTE MAXIMUM RATINGS

Symbol	Description	Min	Max	Units
V_{CC}	Supply Voltage	-0.3	+7.0	V
V_{IN}	Input Voltage	-0.3	$V_{CC}+0.3$	V
T_{OPR}	Operating Temp.	0	70	°C
T_{STG}	Storage Temp.	-55	+150	°C

Notes:

Voltage on all pins with respect to GND. Permanent LSI damage may occur if maximum ratings are exceeded. Normal operation should be recommended operating conditions. If these conditions are exceeded, it could affect reliability of LSI.

Stresses greater than those listed under Absolute Maximum Ratings may cause permanent damage to the device. This is a stress rating only; operation of the device at any condition above those indicated in the operational sections of these specifications is not implied. Exposure to absolute maximum rating conditions for extended periods may affect device reliability.

STANDARD TEST CONDITIONS

The DC Characteristics and capacitance sections below apply for the following standard test conditions, unless otherwise noted. All voltages are referenced to GND (0V). Positive current flows into the referenced pin (Test Load).

Operating Temperature Range:
S = 0°C to 70°C

Voltage Supply Range:
 $+4.5V \leq V_{CC} \leq +5.5V$

All AC parameters assume a load capacitance of 100 pF. Add 10 ns delay for each 50 pF increase in load up to a maximum of 150 pF for the data bus and 100 pF for address and control lines. AC timing measurements are referenced to 1.5 volts (except for clock, which is referenced to the 10% and 90% points). Maximum capacitive load for PHI is 125 pF.

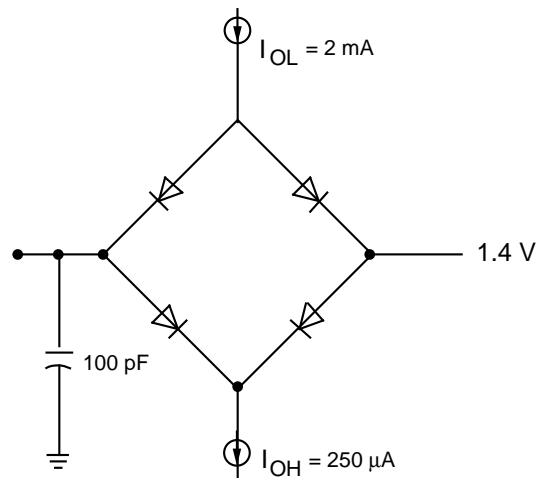

Figure 3. Test Load Diagram

DC CHARACTERISTICS

$V_{DD} = 5.0V \pm 10\%$, $V_{SS} = 0V$ over specified temperature range, unless otherwise noted.

Symbol	Item	Condition	Min.	Typ.	Max.	Unit
V_{IH}	Input "H" Voltage	†				V
V_{IL}	Input "L" Voltage	†				V
V_{OH}	Output "H" Voltage	†				V
V_{OL1}	Output "L" Voltage	†				V
I_{IL}	Input Leakage Current All Inputs Except XTAL,EXTAL	$V_{IN}=0.5$ to $V_{DD}-0.5$			1.0	μA
I_{TL}	Tri-State Leakage Current	$V_{IN}=0.5$ to $V_{DD}-0.5$			1.0	μA
	V_{DD} Supply Current*					
	Normal Operation					
	For 5.0V:	f = 20 MHz		60	120	mA
	For 5.0V:	f = 33 MHz		68	132	mA
I_{CC}^*	Power Dissipation* System Stop Mode					
	For 5.0V:	f = 20 MHz		5	10	mA
	For 5.0V:	f = 33 MHz		7	13	mA

Notes:

† See Class Reference Table

* $V_{IH\ min} = V_{DD} - 1.0V$, $V_{IL\ max} = 0.8V$ (All output terminals are at no load.)

TIMING DIAGRAMS

Z8S180 MPU Timing

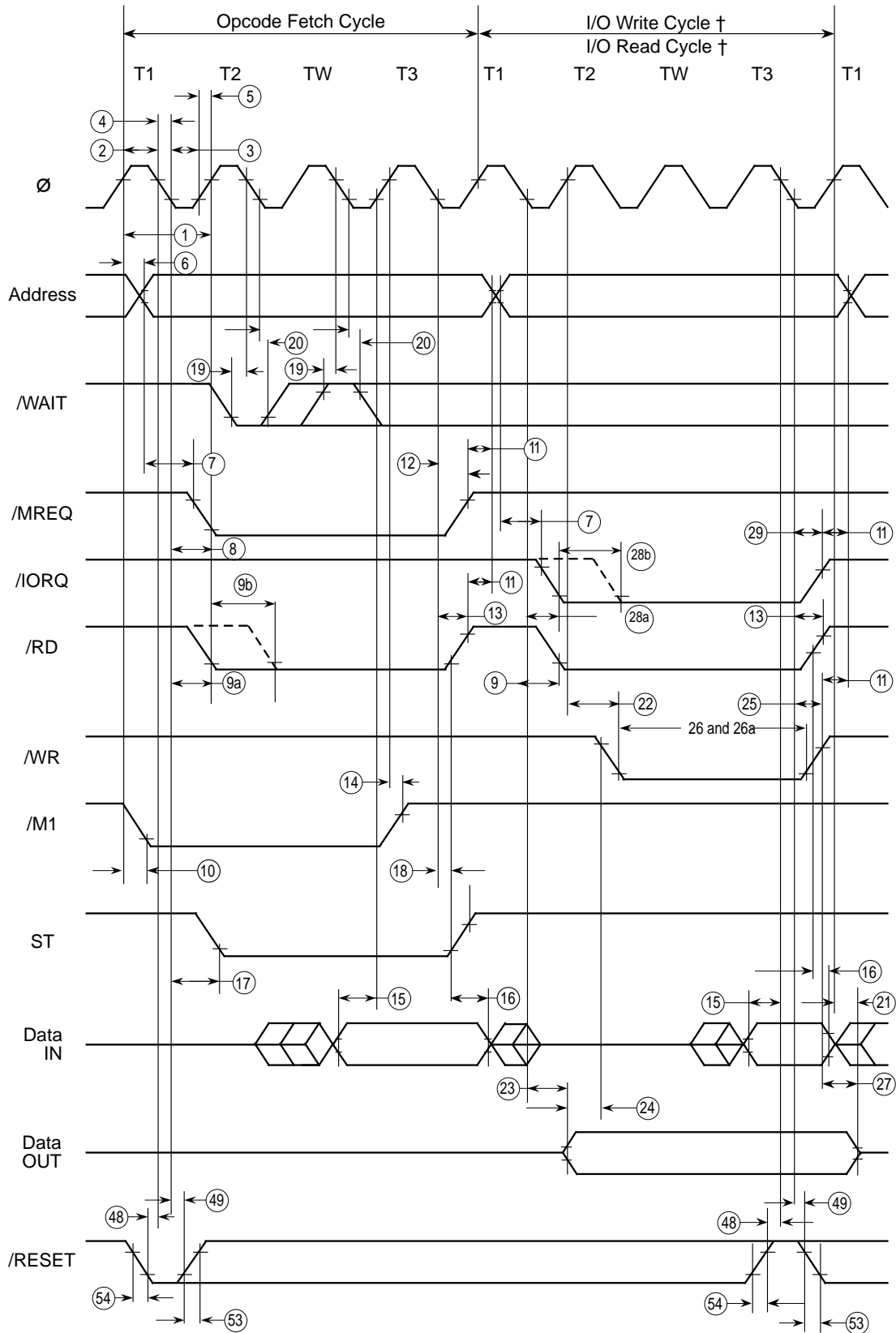

Figure 4. CPU Timing
(Opcode Fetch Cycle, Memory Read/Write Cycle
I/O Read/Write Cycle)

TIMING DIAGRAMS (Continued)

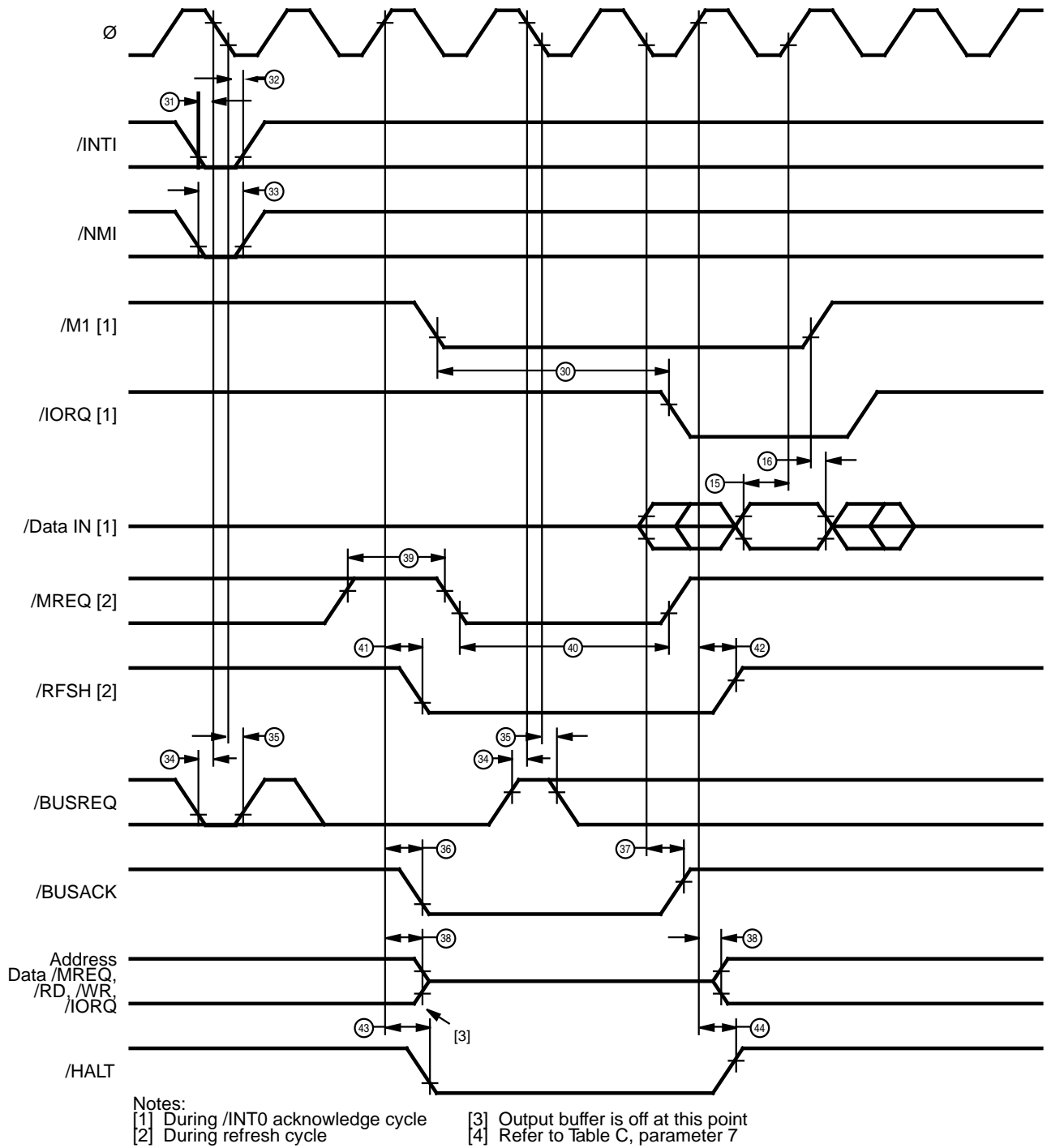

Figure 5. CPU Timing
(/INT0 Acknowledge Cycle, Refresh Cycle, BUS RELEASE mode
HALT mode, SLEEP mode, SYSTEM STOP mode)

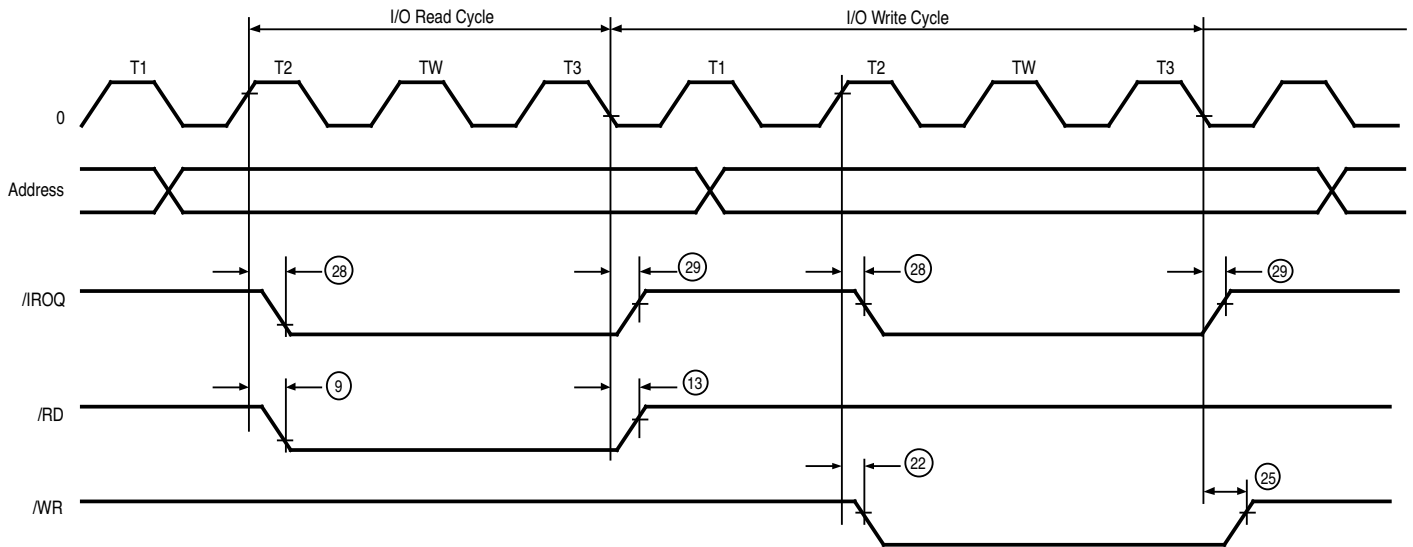
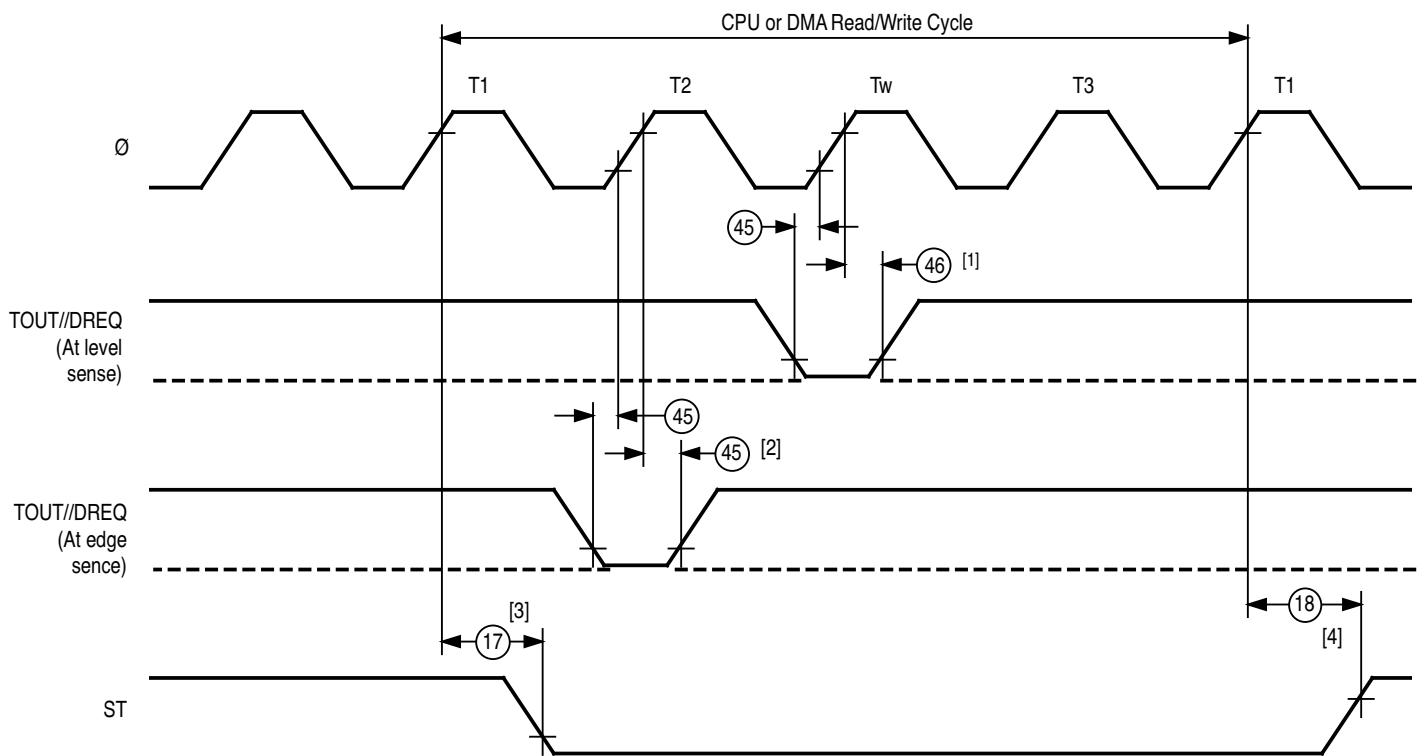

Figure 6. CPU Timing



- DMA Control Signals
 [1] tDRQS and tDRQH are specified for the rising edge of clock followed by T3.
 [2] tDRQS and tDRQH are specified for the rising edge of clock.
 [3] DMA cycle starts.
 [4] CPU cycle starts.

Figure 7. DMA Control Signals

TIMING DIAGRAMS (Continued)

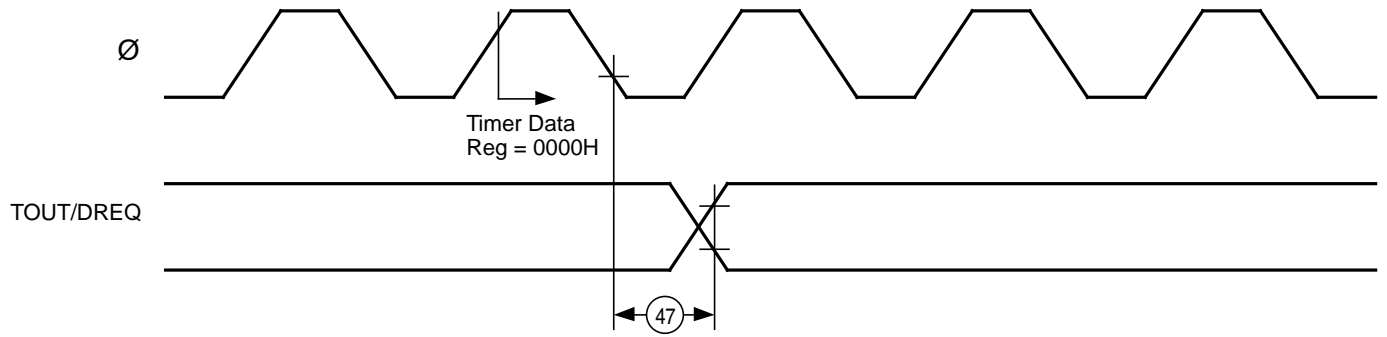

Figure 8. Timer Output Timing

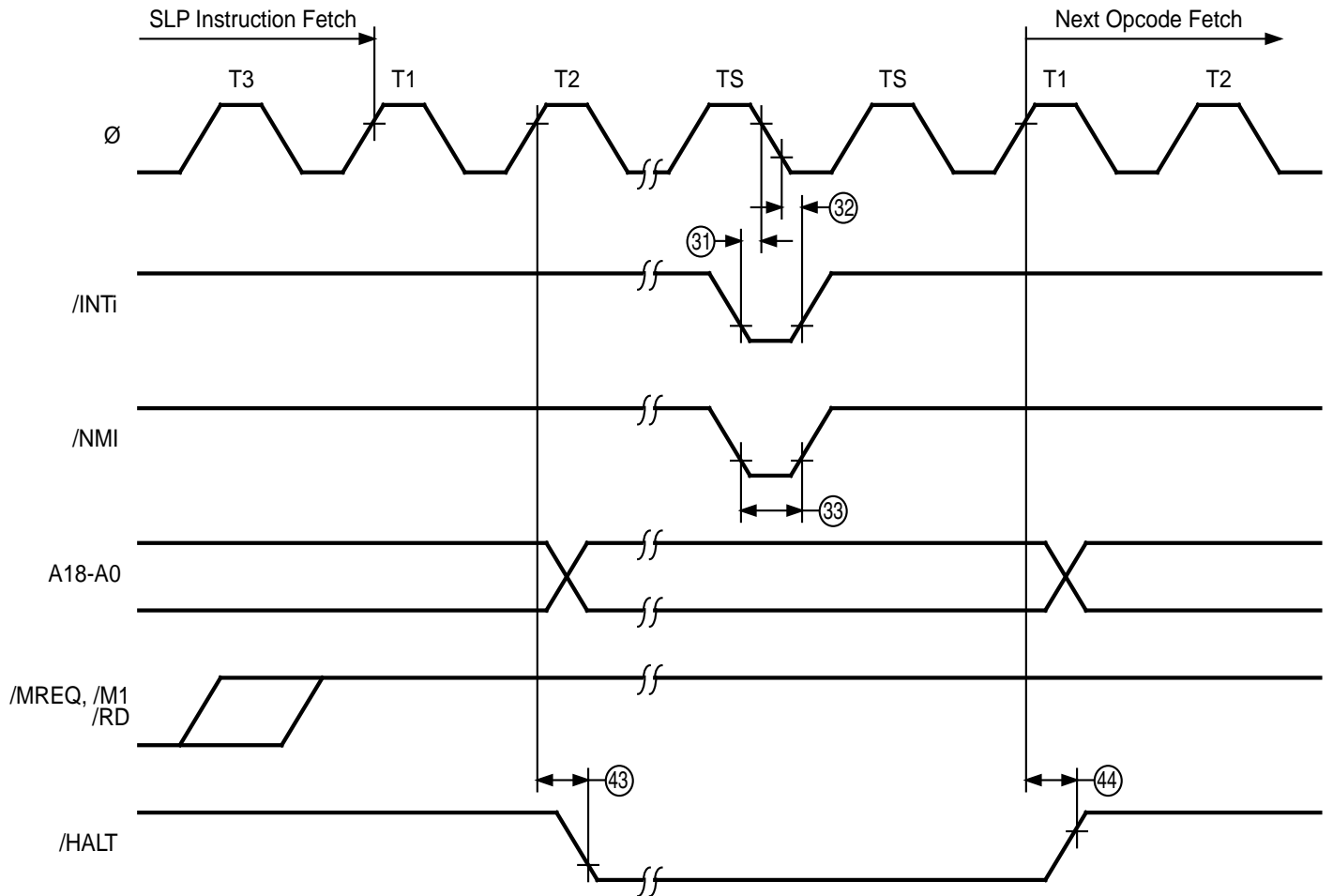

Figure 9. SLEEP Execution Cycle

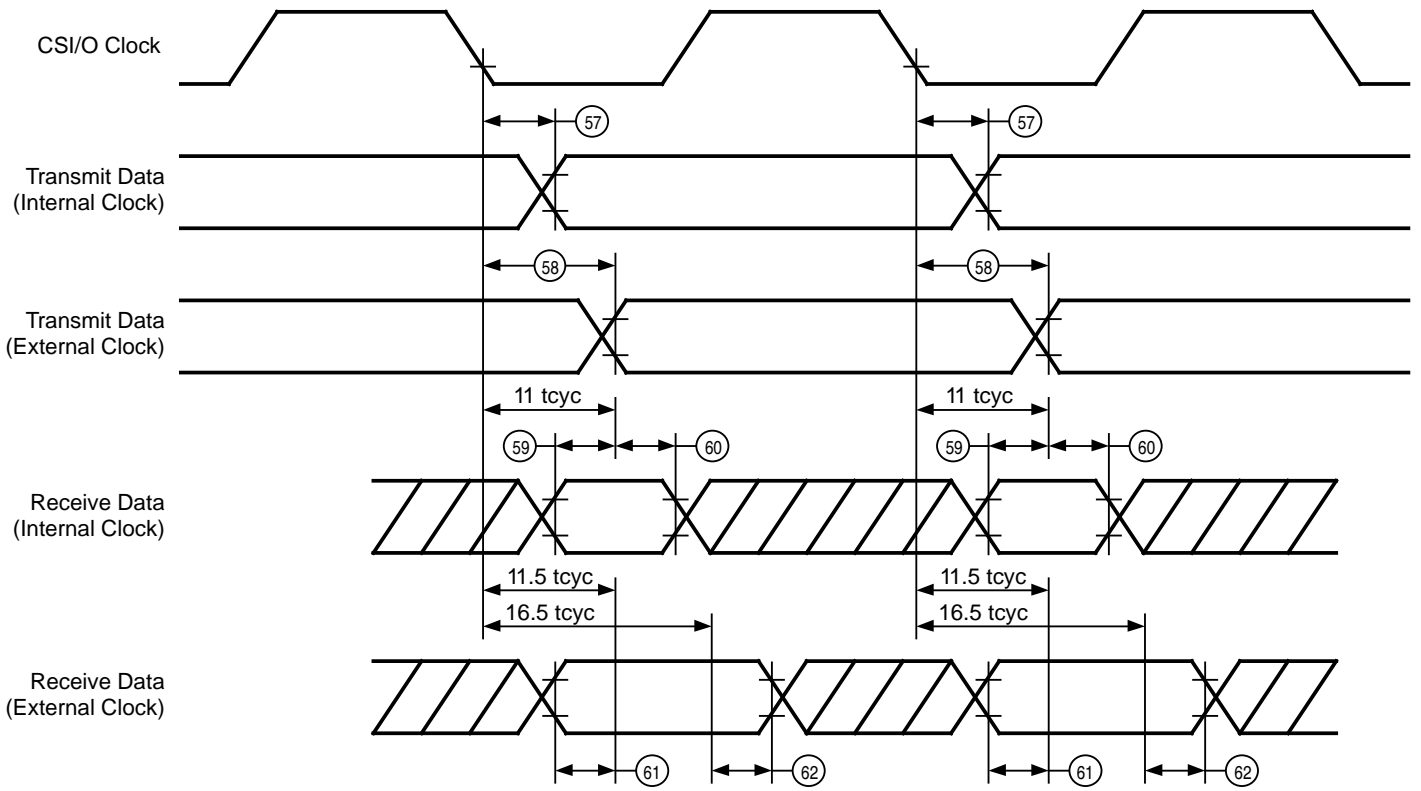

Figure 10. CSI/O Receive/Transmit Timing

TIMING DIAGRAMS (Continued)

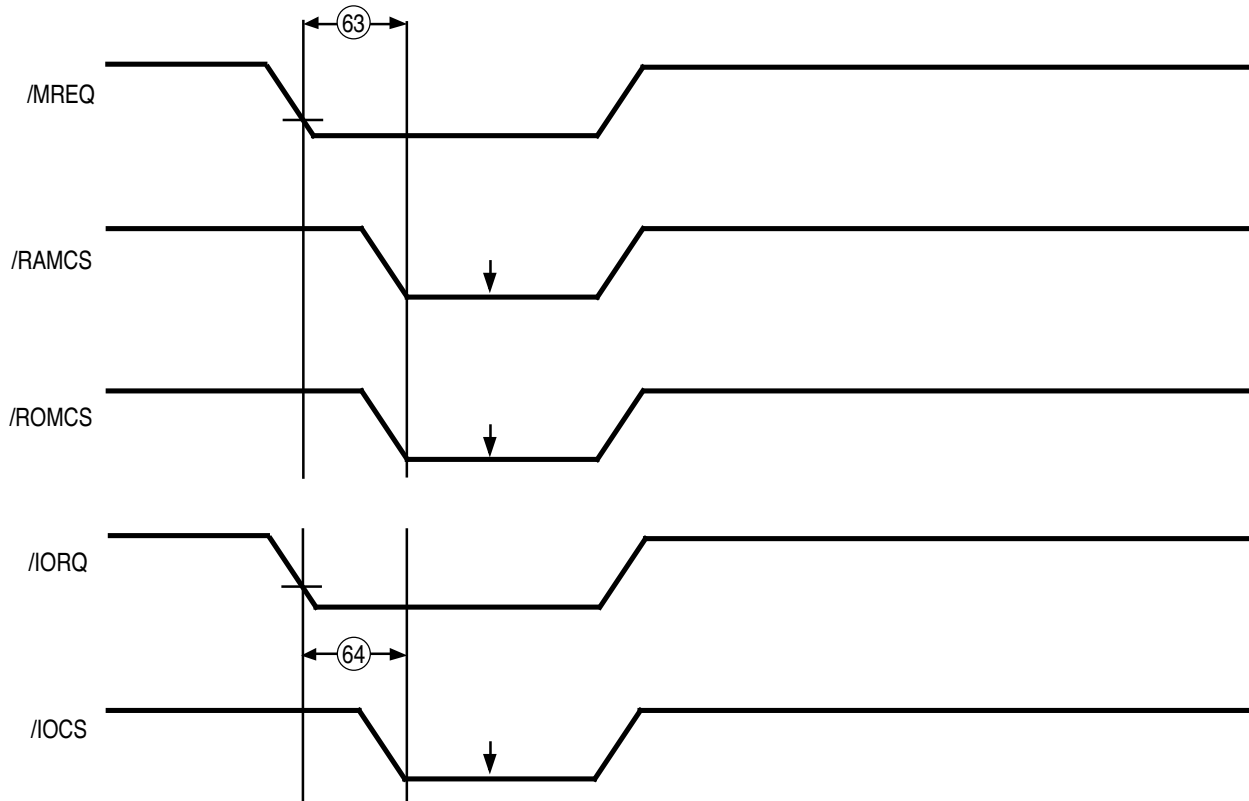

Figure 11. /ROMCS and /RAMCS Timing

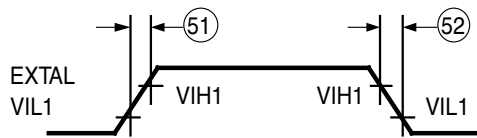

Figure 12. External Clock Rise Time and Fall Time



Figure 13. Input Rise and Fall Time
(Except EXTAL, /RESET)

AC CHARACTERISTICS

$V_{DD} = 5V \pm 10\%$, $V_{SS} = 0V$, $CL = 50$ pF for outputs over specified temperature range, unless otherwise noted.

No.	Symbol	Parameter	Z80185 / Z80195 (20 MHz)		Z80185 / Z80195 (33 MHz)		Units
			Min	Max	Min	Max	
1	t _{cy}	Clock Cycle Time	50	(DC)	33	(DC)	ns
2	t _{CHW}	Clock "H" Pulse Width	15		10		ns
3	t _{CLW}	Clock "L" Pulse Width	15		10		ns
4	t _{cf}	Clock Fall Time		10		5	ns
5	t _{cr}	Clock Rise Time		10		5	ns
6	t _{AD}	PHI Rising to Address Valid	30		15		ns
7	t _{AS}	Address Valid to (MREQ Falling or IORQ Falling)	5		5		ns
8	t _{MED1}	PHI Falling to MREQ Falling Delay		25		15	ns
9a	t _{RDD1}	PHI Falling to RD Falling Delay (IOC=1)		25		15	ns
9b	t _{RDD1}	PHI Rising to RD Falling Delay (IOC=0)		25		15	ns
10	t _{M1D1}	PHI Rising to M1 Falling Delay		35		15	ns
11	t _{AH}	Address Hold Time from (MREQ, IOREQ, RD, WR)	5		5		ns
12	t _{MED2}	PHI Falling to MREQ Rising Delay		25		15	ns
13	t _{RDD2}	PHI Falling to RD Rising Delay		25		15	ns
14	t _{M1D2}	PHI Rising to M1 Rising Delay		40		15	ns
15	t _{DRS}	Data Read Setup Time	10		5		ns
16	t _{DRH}	Data Read Hold Time	0		0		ns
17	t _{STD1}	PHI Falling to ST Falling Delay		30		15	ns
18	t _{STD2}	PHI Falling to ST Rising Delay		30		15	ns
19	t _{WS}	WAIT Setup Time to PHI Falling	15		10		ns
20	t _{WH}	WAIT Hold Time from PHI Falling	10		5		ns
21	t _{WDZ}	PHI Rising to Data Float Display		35		20	ns
22	t _{WRD1}	PHI Rising to WR Falling Delay		25		15	ns
23	t _{WDD}	PHI Rising to Write Data Delay Time		25		15	ns
24	t _{WDS}	Write Data Setup Time to WR Falling	10		10		ns
25	t _{WRD2}	PHI Falling to WR Rising Delay		25		15	ns
26	t _{WRP}	Write Pulse Width (Memory Write Cycle)	75		45		ns
26a	t _{WRP}	Write Pulse Width (I/O Write Cycle)	130		70		ns
27	t _{WDH}	Write Data Hold Time From (WR Rising)	10		5		ns

Notes:

Specifications 1 through 5 refer to an external clock input on EXTAL, and provisionally to PHI clock output. When a quartz crystal is used with the on-chip oscillator, a lower maximum frequency than that implied by spec. #1 may apply.

AC CHARACTERISTICS (Continued)

No.	Symbol	Parameter	Z80185 / Z80195 (20 MHz)		Z80185 / Z80195 (33 MHz)		Units
			Min	Max	Min	Max	
28a	tIOD	PHI Falling to IORQ Falling Delay (IOC = 1)		25		15	ns
28b	tIOD	PHI Rising to IORQ Falling Delay (IOC = 0)		25		15	ns
29	tIOD2	PHI Falling to IORQ Rising Delay		25		15	ns
30	tIOD3	M1 Falling to IORQ Falling Delay	100		80		ns
31	tINTS	INT Setup Time to PHI Falling	20		15		ns
32	tINTH	INT Hold Time from PHI Falling	10		10		ns
33	tNMIW	NMI Pulse Width	35		25		ns
34	tBRS	BUSREQ Setup Time to PHI Falling	10		10		ns
35	tBRH	BUSREQ Hold Time from PHI Falling	10		10		ns
36	tBAD1	PHI Rising to BUSACK Falling Delay		25		15	ns
37	tBAD2	PHI Falling to BUSACK Rising Delay		25		15	ns
38	tBZD	PHI Rising to Bus Floating Delay Time		40		30	ns
39	tMEWH	MREQ Pulse Width (High)	t _{cy} - 15		t _{cy} - 10		ns
40	tMEWL	MREQ Pulse Width (Low)	2t _{cy} - 15		2t _{cy} - 10		ns
41	tRFD1	PHI Rising to RFSH Falling Delay		20		15	ns
42	tRFD2	PHI Rising to RFSH Rising Delay		20		15	ns
43	tHAD1	PHI Rising to HALT Falling Delay		15		15	ns
44	tHAD2	PHI Rising to HALT Rising Delay		15		15	ns
45	tDRQS	DREQ Setup Time to PHI Rising	20		15		ns
46	tDRQH	DREQ Hold Time from PHI Rising	20		15		ns
47	tTOD	PHI Falling to Timer Output Delay		75		50	ns
48	tRES	RESET Setup Time to PHI Falling	40		25		ns
49	tREH	RESET Hold Time From PHI Falling	25		15		ns
50	tOSC	Oscillator Stabilization Time		20		20	ms
51	tEXr	External Clock Rise Time (EXTAL)		10		5	ns
52	tEXf	External Clock Fall Time (EXTAL)		10		5	ns
53	tRr	Reset Rise Time		50		50	ms
54	tRf	Reset Fall Time		50		50	ms
55	tIr	Input Rise Time (Except EXTAL, RESET)		50		50	ns
56	tIf	Input Fall Time (Except EXTAL, RESET)		50		50	ns
57	tSTDI	CSIO Transmit Data Delay Time (Internal Clock Operation)		75		60	ns
58	tSTDE	CSIO Transmit Data Delay Time (External Clock Operation)		7.5 t _{cy} + 75		7.5 t _{cy} + 60	ns
59	tSRSI	CSIO Receive Data Setup Time (Internal Clock Operation)		75		60	ns
60	tSRHI	CSIO Receive Data Hold Time (Internal Clock Operation)		75		60	ns
61	tSRSE	CSIO Receive Data Setup Time (External Clock Operation)		75		60	ns
62	tSRHE	CSIO Receive Data Hold Time (External Clock Operation)		75		60	ns
63	tdCS	MREQ Valid to RAMCS and ROMCS Valid Delay		15		15	ns
64	tdIOCS	Rising IORQ Valid to Rising IOCS Valid Delay		10		10	ns

AC CHARACTERISTICS (Continued)

Read/Write External Bus Master Timing

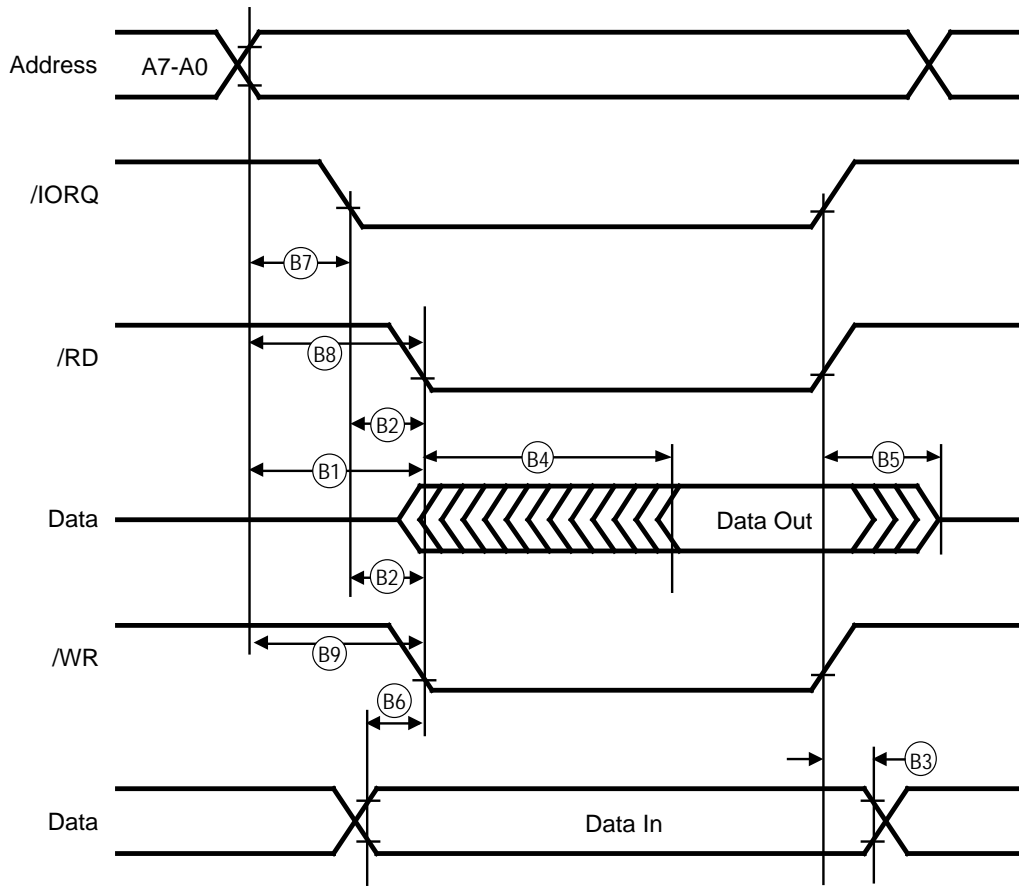

Figure 14. Read/Write External Bus Master Timing

AC CHARACTERISTICS (Continued)

General-Purpose I/O Timing Port Timing

Parameters referenced in Figure 15 appear in the following Tables. **Note:** Port 2 timing is different, even when Bidirectional Centronics feature is not in active use.

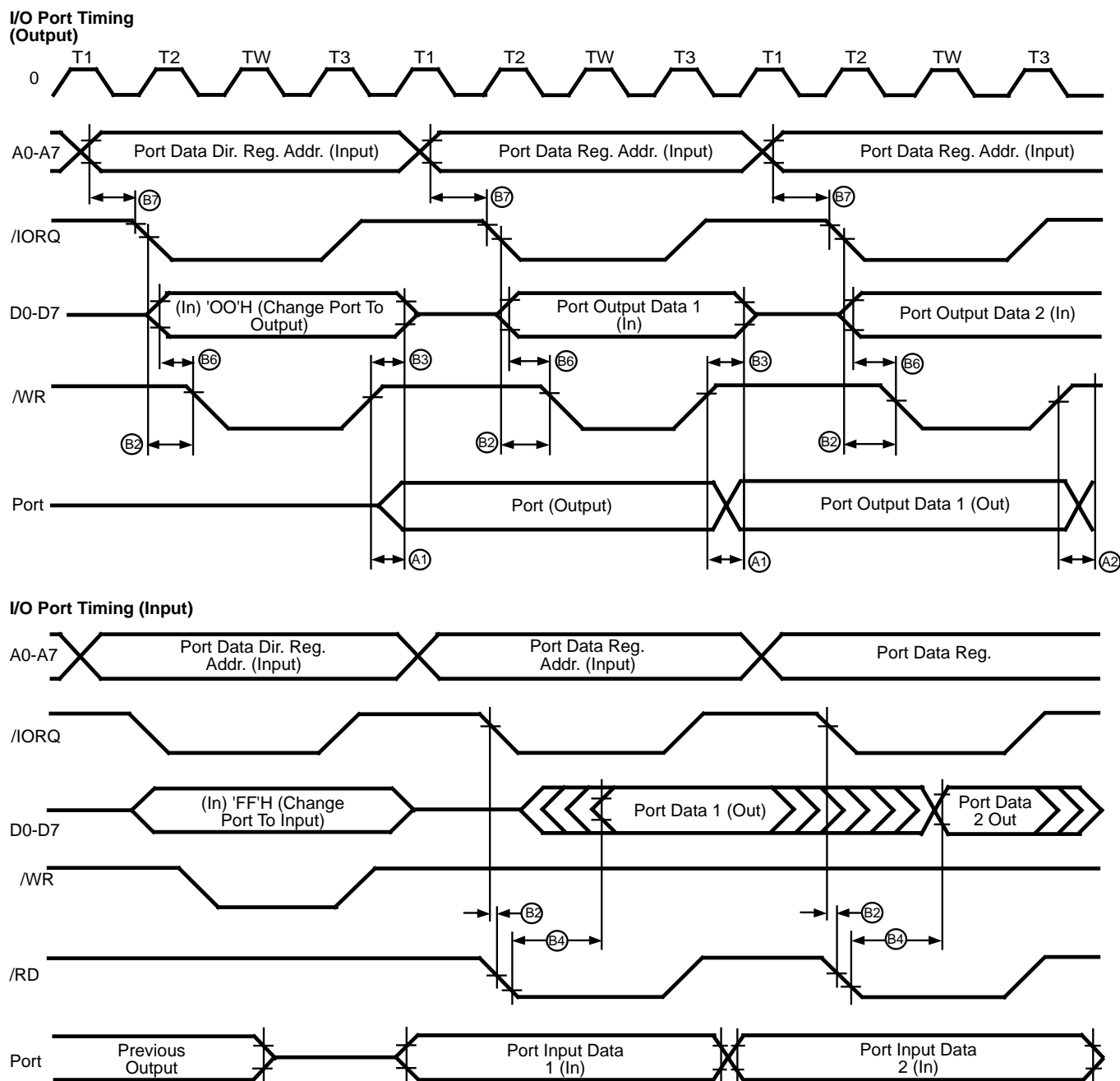

Figure 15. PORT Timing

I/O Port Timing

No.	Symbol	Parameter	Z80185 / Z80195 (20 MHz)		Z80185 / Z80195 (33 MHz)		Units
			Min	Max	Min	Max	
A1	TdWR (PIA)	Data Valid Delay from WR Rise	60		60	ns	

External Bus Master Timing

No.	Symbol	Parameter	Z80185 / Z80195 (20 MHz)		Z80185 / Z80195 (33 MHz)		Units
			Min	Max	Min	Max	
B1	TsA(wf) (rf)	Address Valid to WR or RD Fall Time	40		40		ns
B2	TsIO(wf) (rf)	IORQ Fall to WR or RD Fall Time	20		20		ns
B3	Th	Data Hold Time (from WR Rise)	5		5		ns
B4	TdRD(DO)	RD Fall to Data Out Delay	35		35		ns
B5	TdRlr(DOz)	RD, IORQ Rise to Data Float Time	5		5		ns
B6	TsDI(WRf)	Data In to WR Fall Setup Time	20		20		ns
B7	TsA(IORQf)	Address to IORQ Fall Setup Time	20		20		ns
B8	TsA(RDf)	Address to RD Fall Setup Time	40		40		ns
B9	TsA(WRf)	Address to WR Fall Setup Time	40		40		ns

AC CHARACTERISTICS (Continued)

EMSCC Timing

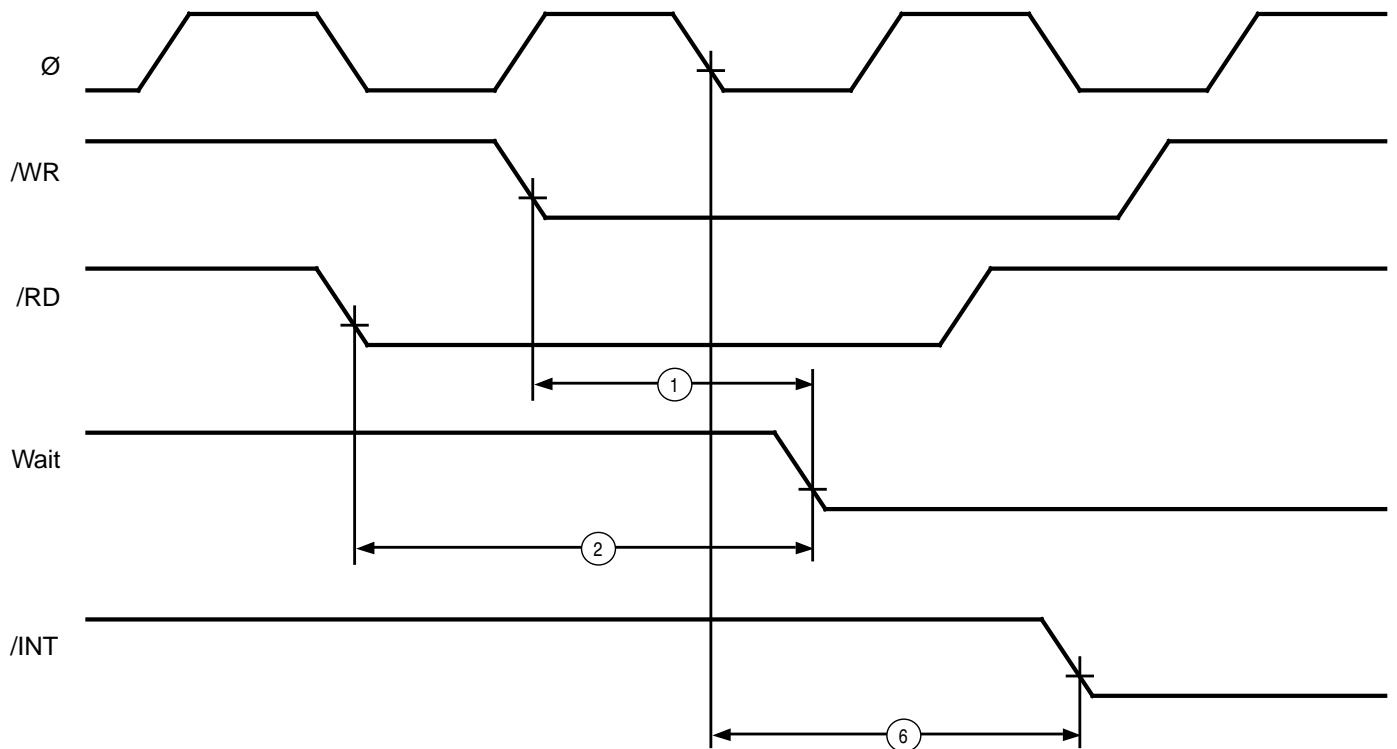

Figure 16. EMSCC AC Parameters

EMSCC Timing Parameters

No.	Symbol	Parameter	20 MHz		Unit
			Min	Max	
1	TdWR(W)	/WR Fall to Wait Valid Delay		50	ns
2	TdRD(W)	/RD Fall to Wait Valid Delay		50	
6	TdPC(INT)	Clock to /INT Valid Delay		160	

EMSCC General Timing Diagram

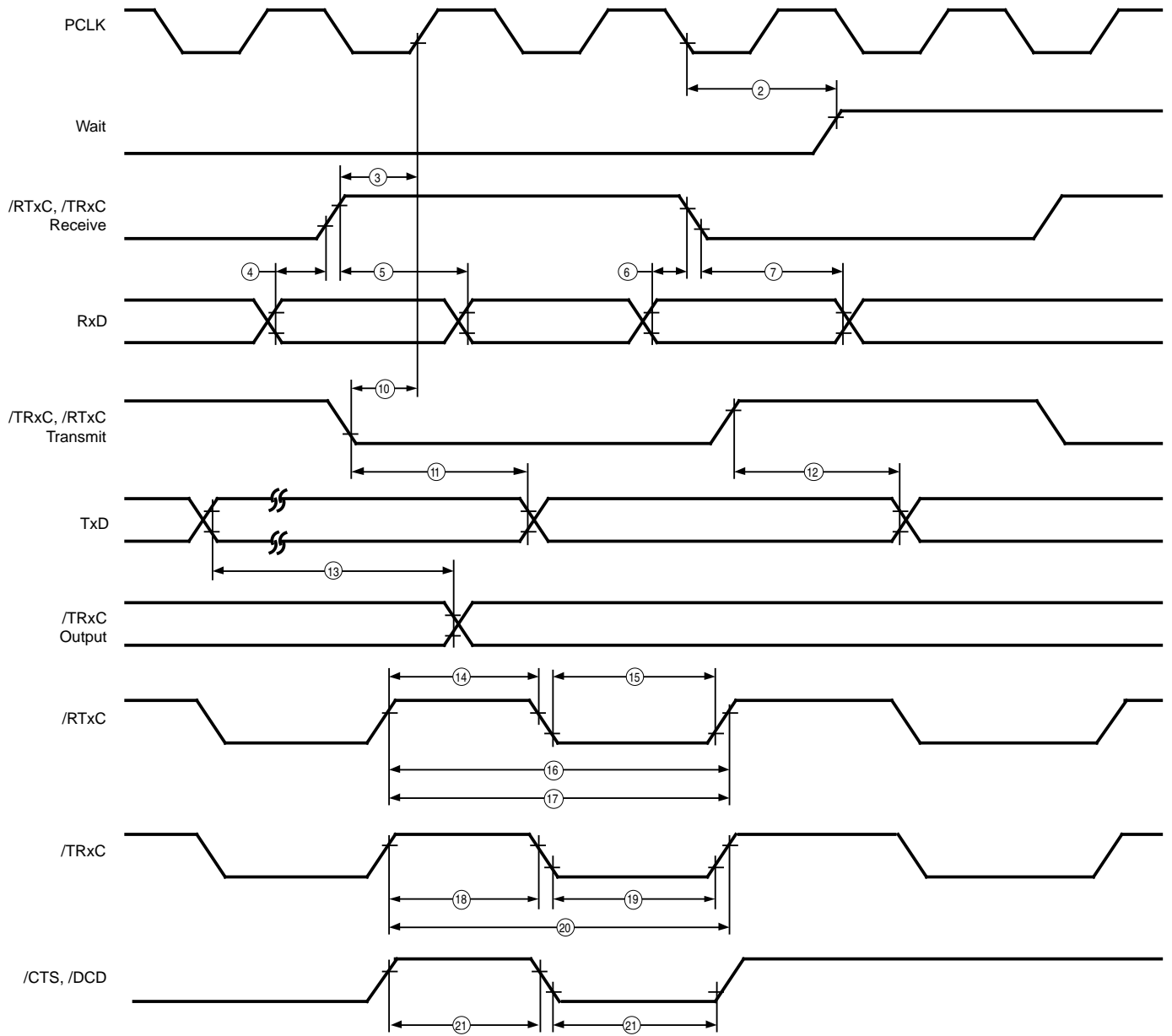

Figure 17. EMSCC General Timing Diagram

AC CHARACTERISTICS (Continued)**EMSCC General Timing**

No.	Symbol	Parameter	20 MHz		Notes
			Min	Max	
2	TdPC(W)	/PCLK to Wait Inactive		170	
3	TsRxC(PC)	/RxC to /PCLK Setup Time	NA		[1,4]
4	TsRxD(RxCr)	RxD to /RxC Setup Time		0	[1]
5	ThRxD(RxCr)	RxD to /RxC Hold Time	45		[1]
6	TsRxD(RxCf)	RxD to /RxC Setup Time	0		[1,5]
7	ThRxD(RxCf)	RxD to /RxC Hold Time	45		[1,5]
10	TsTxC(PC)	/TxC to /PCLK Setup Time	NA		[2,4]
11	TdTxCf(TXD)	/TxC to TxD Delay		70	[2]
12	TdTxCr(TXD)	/TxC to TxD Delay		70	[2,5]
13	TdTxD(TRX)	TxD to TRxC Delay	80		70
14	TwRTxh	RTxC High Width	70		[6]
15	TwRTxl	TRxC Low Width	70		[6]
16a	TcRTx	RTxC Cycle Time	200		[6,7]
16b	TxRx(DPLL)	DPLL Cycle Time Min	50		[7,8]
17	TcRTxx	Crystal OSC. Period	61	1000	[3]
18	TwTRxh	TRxC High Width	70		[6]
19	TwTRxl	TRxC Low Width	70		[6]
20	TcTRx	TRxC Cycle Time	200		[6,7]
21	TwExT	DCD or CTS Pulse Width	60		

Notes:

- [1] RxC is /RTxC or /TRxC, whichever is supplying the receive clock.
 [2] TxC is /TRxC or /RTxC, whichever is supplying the transmit clock.
 [3] Both /RTxC and /SYNC have 30 pF capacitors to Ground connected to them.
 [4] Synchronization of RxC to PCLK is eliminated in divide-by-four operation.
 [5] Parameter applies only to FM encoding/decoding.
 [6] Parameter applies only for transmitter and receiver; DPLL and baud rate generator timing requirements are identical to case PCLK requirements.
 [7] The maximum receive or transmit data rate is 1/4 PCLK.
 [8] Applies to DPLL clock source only. Maximum data rate of 1/4 PCLK still applies. DPLL clock should have a 50% duty cycle.

These AC parameter values are preliminary and subject to change without notice.

EMSCC System Timing Diagram

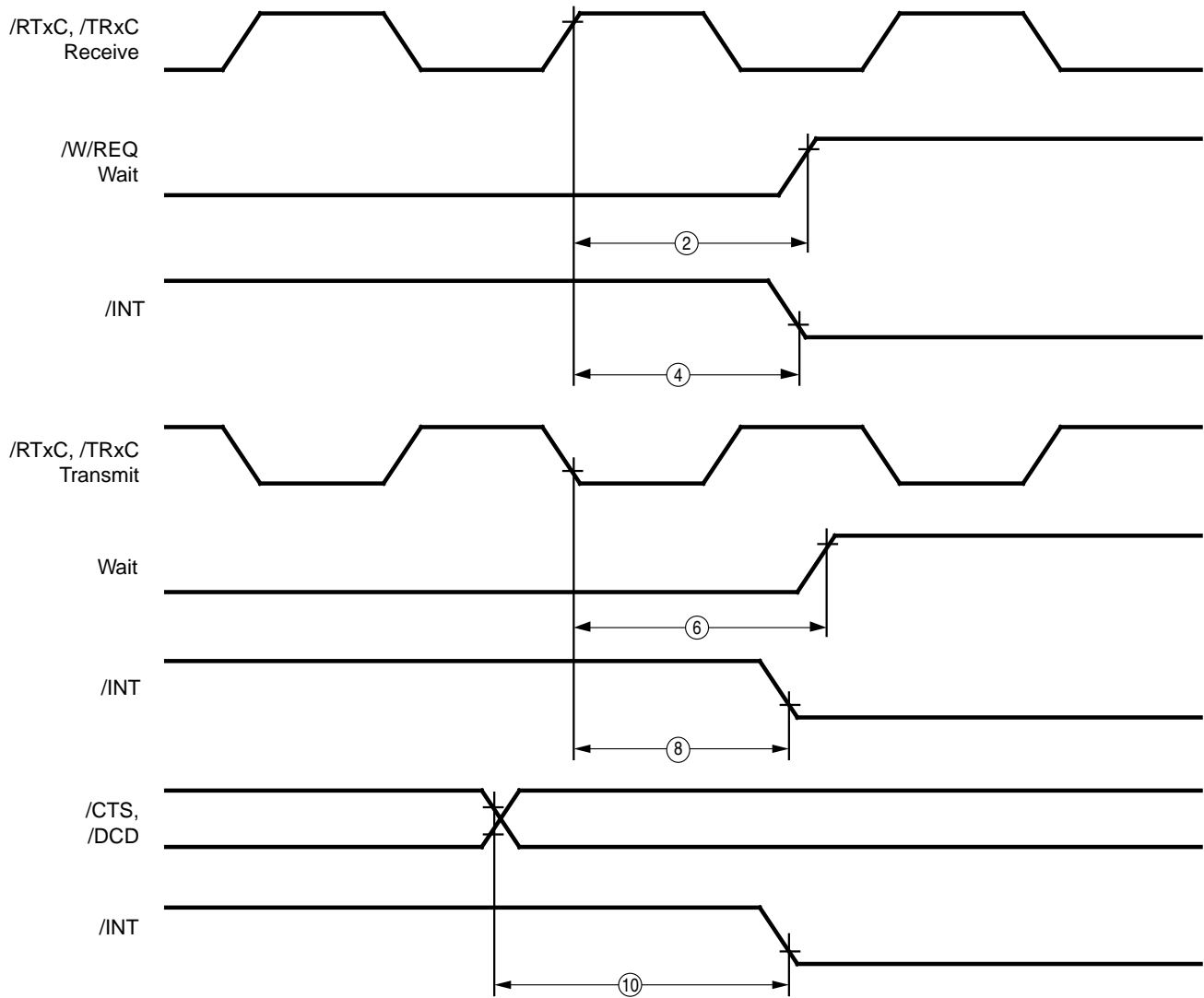

Figure 18. EMSCC System Timing

AC CHARACTERISTICS (Continued)

EMSCC System Timing

No.	Symbol	Parameter	20 MHz		Notes
			Min	Max	
2	TdRxC(W)	/RxC to /Wait Inactive	13	18	[1,2]
4	TdRxC(INT)	/RxC to /INT Valid	15	22	[1,2]
6	TdTxC(W)	/TxC to /Wait Inactive	8	17	[1,3]
8	TdTxC(INT)	/TxC to /INT Valid	9	17	[1,3]
10	TdExT(INT)	/DCD or /CTS to /INT Valid	3	9	[1]

Notes:

[1] Open-drain output, measured with open-drain test load.

[2] /RxC is /RTxC or /TRxC, whichever is supplying the receive clock.

[3] /TxC is /TRxC or /RTxC, whichever is supplying the transmit clock.

[4] Units equal to TcPc

These AC parameter values are preliminary and subject to change without notice.

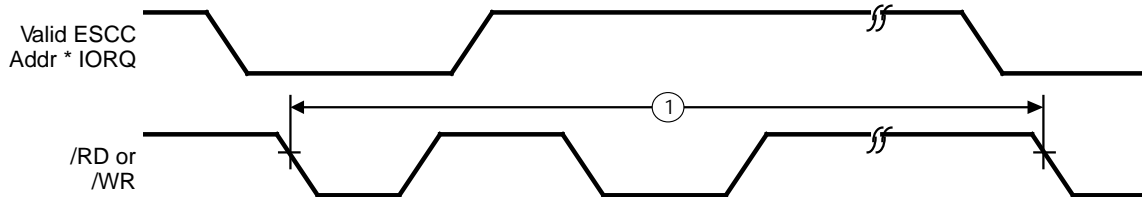

Figure 19. EMSCC External Bus Master Timing

External Bus Master Interface Timing (SCC Related Timing)

No	Symbol	Parameter	Z80185 / Z80195 (20 MHz)		Z80185 / Z80195 (33 MHz)		Unit	Notes
			Min	Max	Min	Max		
1	TrC	Valid Access Recovery Time	4TcC		4TcC		ns	[1]

Notes:

[1] Applies only between transactions involving the EMSCC.

These AC parameter values are preliminary and subject to change without notice.

T_{CC} = EMSCC Clock Period Time

AC CHARACTERISTICS (Continued)

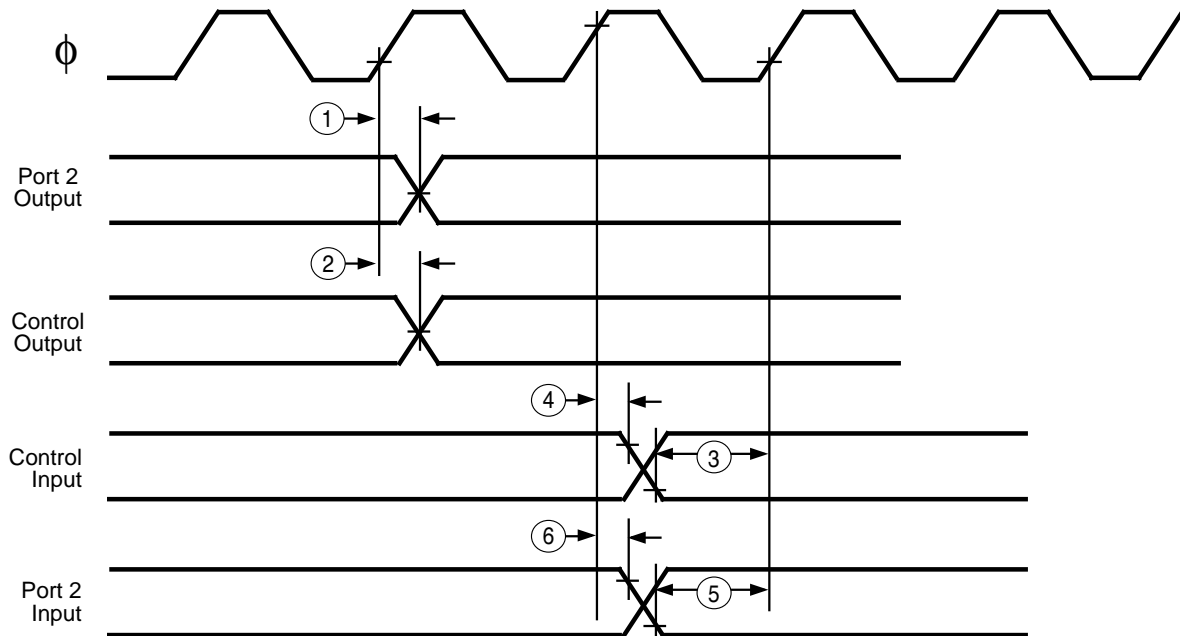

Figure 20. P1284 Bidirectional Centronics Interface Timing

P1284 Bidirectional Centronics Interface Timing

No.	Parameter	Min	Max	Units	Notes
1	CLK High to Port 2 Output		12	ns	
2	CLK High to Control Output		12	ns	[1]
3	Setup Time for Control Input to CLK High for Guaranteed Recognition	10		ns	[2]
4	Hold Time for Control Input from CLK High for Guaranteed Recognition	5		ns	[2]
5	Setup Time for Port 2 Inputs to CLK High for Guaranteed Recognition	10		ns	
6	Hold Time for Port 2 Inputs to CLK High for Guaranteed Recognition	5		ns	

Notes:

[1] Peripheral Mode	Control Outputs	Host Mode
Busy/PtrBusy/PeriphAck nAck/PtrClk/PeriphClk PError/AckDataReq/nAckReverse nFault/nDataAvail/nPeriphRequest Select/Xflag		nStrobe/HostClk nAutoFd/HostBusy/HostAck nSelectIn/P1284Active nInit/nReverseRequest

[2] Host Mode	Control Inputs	Peripheral Mode
Busy/PtrBusy/PeriphAck nAck/PtrClk/PeriphClk PError/AckDataReq/nAckReverse nFault/nDataAvail/nPeriphRequest Select/Xflag		nStrobe/HostClk nAutoFd/HostBusy/HostAck nSelectIn/P1284Active nInit/nReverseRequest

PIN DESCRIPTIONS

Z80185 CPU Signals

A0-A19. *Address Bus* (input/output, active High, tri-state). A0-A19 is a 20-bit address bus that provides the address for memory data bus cycles up to 1 Mbyte, and I/O data bus cycles up to 64 Kbytes. The address bus enters a High impedance state during reset and external bus acknowledge cycles. This bus is an input when /BUSACK is Low. No address lines are multiplexed with any other signals.

D0-D7. *Data Bus* (bidirectional, active High, tri-state). D0-D7 constitute an 8-bit bidirectional data bus, used to transfer information to and from I/O and memory devices. The data bus enters the High impedance state during reset and external bus acknowledge cycles, as well as during SLEEP and HALT states.

/RD. *Read* (input/output, active Low, tri-state). /RD indicates that the CPU is ready to read data from memory or an I/O device. The addressed I/O or memory device should use this signal to gate data onto the CPU data bus. This pin is tri-stated during bus acknowledge cycles.

/WR. *Write* (input/output, active Low, tri-state). /WR indicates that the CPU data bus holds valid data to be stored at the addressed I/O or memory location. This pin is tri-stated during bus acknowledge cycles.

/IORQ. *I/O Request* (input/output, active Low, tri-state). /IORQ indicates that the address bus contains a valid I/O address for an I/O read or I/O write operation. /IORQ is also generated, along with /M1, during the acknowledgment of the /INT0 input signal to indicate that an interrupt response vector can be placed onto the data bus. This pin is tri-stated during bus acknowledge cycles.

/M1. *Machine Cycle 1* (input/output, active Low). Together with /MREQ, /M1 indicates that the current cycle is the opcode fetch cycle of an instruction execution. Together with /IORQ, /M1 indicates that the current cycle is for an interrupt acknowledge. It is also used with the /HALT and ST signal to indicate the status of the CPU machine cycle. The processor can be configured so that this signal is compatible with the /M1 signal of the Z80, or with the /LIR signal of the Z64180. This pin is tri-stated during bus acknowledge cycles.

/MREQ. *Memory Request* (input/output, active Low, tri-state). /MREQ indicates that the address bus holds a valid address for a memory read or memory write operation. It is included in the /RAMCS and /ROMCS signals, and because of this may not be needed in some applications. This pin is tri-stated during bus acknowledge cycles.

/WAIT. (input/open-drain output, active Low.) /WAIT indicates to the MPU that the addressed memory or I/O devices are not ready for a data transfer. This input is used to induce additional clock cycles into the current machine cycle. External devices should also drive this pin in an open-drain fashion. This results in a “wired OR” of the Wait indications produced by external devices and those produced by the two separate Wait State generators in the Z80185. If the wire-ORed input is sampled Low, then additional wait states are inserted until the /WAIT input is sampled High, at which time the cycle is completed.

/HALT. *Halt/Sleep Status* (output, active Low). This output is asserted after the CPU has executed either the HALT or SLP instruction, and is waiting for either non-maskable or maskable interrupt before operation can resume. It is also used with the /M1 and /ST signals to indicate the status of the CPU machine cycle. On exit of Halt/Sleep, the first instruction fetch is delayed 16 clock cycles after the /HALT pin goes High.

/BUSACK. *Bus Acknowledge* (output, active Low). /BUSACK indicates to the requesting device that the MPU address and data bus, as well as some control signals, have entered their High impedance state.

/BUSREQ. *Bus Request* (input, active Low). This input is used by external devices (such as DMA controllers) to request access to the system bus. This request has a higher priority than /NMI and is always recognized at the end of the current machine cycle. This signal stops the CPU from executing further instructions and places the address and data buses, and other control signals, into the High impedance state.

/NMI. *Non-Maskable Interrupt* (input, negative edge triggered). /NMI has a higher priority than /INT and is always recognized at the end of an instruction, regardless of the state of the interrupt enable flip-flops. This signal forces CPU execution to continue at location 0066H.

/INT0. *Maskable Interrupt Request 0* (input/open-drain output, active Low). This signal is generated by internal and external I/O devices. External devices should also drive this signal in an open-drain fashion. The CPU will honor this request at the end of the current instruction cycle as long as it is enabled, and the /NMI and /BUSREQ signals are inactive. The CPU acknowledges this interrupt request with an interrupt acknowledge cycle. During this cycle, both the /M1 and /IORQ signals will become active.

/INT1, /INT2. *Maskable Interrupt Requests 1 and 2* inputs, active Low). These signals are generated by external I/O devices. The CPU will honor these requests at the end of the current instruction cycle as long as the /NMI, /BUSREQ, and /INT0 signals are inactive. The CPU will acknowledge these interrupt requests with an interrupt acknowledge cycle. Unlike the acknowledgment for /INT0 during this cycle, neither the /M1 nor the /IORQ signals will become active. These pins may be programmed to provide active Low level, rising or falling edge interrupts. The level of the external /INT1 and /INT2 pins may be read in the Interrupt Edge Register.

/RFSH. *Refresh* (output, active Low, tri-state). /RFSH and /MREQ active indicate that the current CPU machine cycle and the contents of the address bus should be used for refresh of dynamic memories. The low order eight bits of the address bus (A7-A0) contain the refresh address.

Z80185 UART and CSIO Signals

CKA0/CKS. *Asynchronous Clock 0 or Serial Clock* (input/output). An optional clock input or output for ASCII channel 0 or the Clocked Serial I/O Port.

/DCD0/CKA1. *Data Carrier Detect 0 or Asynchronous Clock 1* (input/output). A Low-active modem status input for ASCII channel 0, or a clock input or output for ASCII channel 1.

/RTS0/TxS. *Request to Send 0 or Clocked Serial Transmit Data* (output). A programmable modem control output for ASCII channel 0, or the serial output from the CSIO channel.

/CTS0/RxS. *Clear to Send 0 or Clocked Serial Receive Data* (input). A Low-active modem control input for ASCII channel 0, or the serial data input to the CSIO channel.

TXA0. *Transmit Data 0* (output). This output transmits data from ASCII channel 0.

RXA0. *Receive Data 0* (input). This input receives data for ASCII channel 0.

RXA1. *Receive Data 1* (input). This input receives data for ASCII channel 1.

TXA1. *Transmit Data 1* (output). This output transmits data from ASCII Channel 1.

Multiplexed Signal

TOUT//DREQ. *Timer Out or External DMA Request* (input or output). This pin can be programmed to be either TOUT, the High-active pulse output from PRT channel 1, or a Low-active DMA Request input from an external peripheral.

Z80185 EMSCC Signals

TXD. *Transmit Data* (output). This output transmits serial data at standard TTL levels.

RXD. *Receive Data* (input). This input receives serial data at standard TTL levels.

/TRXC. *Transmit/Receive Clock* (input or output). This pin functions under program control. /TRXC may supply the receive clock or the transmit clock in the input mode or supply the output of the digital phase-locked loop, the crystal oscillator, the baud rate generator, or the transmit clock in the output mode.

/RTXC. *Receive/Transmit Clock* (input). This pin functions under program control. /RTXC may supply the receive clock, the transmit clock, the clock for the baud rate generator, or the clock for the digital phase-locked loop. The receive clock may be 1, 16, 32, or 64 times the data rate in asynchronous mode.

/CTS. *Clear To Send* (input, active Low). If this pin is programmed as an "auto enable", a Low on it enables the EMSCC transmitter. If not programmed as an auto enable, it can be used as a general-purpose input. This pin is Schmitt-trigger buffered to accommodate slow rise-times. The EMSCC detects transitions on this input and can interrupt the processor on either logic level transition.

/DCD. *Data Carrier Detect* (input, active Low). This pin functions as an EMSCC receiver enable when programmed as an "auto enable"; otherwise it can be used as a general-purpose input pin. The pin is Schmitt-trigger buffered to accommodate slow rise-times. The EMSCC detects transitions on this pin and can interrupt the processor on either logic level transition.

PIN DESCRIPTIONS (Continued)

EMSCC Signals

/RTS. *Request to Send* (output, active Low). When the Request to Send (RTS) bit in Write Register 5 is set, the /RTS signal goes Low. When the RTS bit is reset in the Asynchronous mode and auto enables is on, the signal goes High after the transmitter is empty. In Synchronous mode, or in Asynchronous mode with auto enables off, the /RTS pin strictly follows the state of the RTS bit. Thus the pin can be used as a general-purpose output. In a special "AppleTalk" mode on the Z80185, the pin is under hardware control.

/DTR. *Data Terminal Ready* (outputs, active Low). The "/DTR//REQ" functionality found in other SCC family members has been reconfigured internal to the EMSCC megacell. The /DTR output is routed to this pin, while the /REQ signal is routed to the DMA request multiplexing logic as described in a later section on the EMSCC. This pin follows the state of the DTR bit in WR5 of the EMSCC.

Note: The /W/REQ pin present on other SCC family members has its two possible functions reconfigured internal to the EMSCC, and both functions are handled internally to the Z80185. The Wait output of the EMSCC drives the /WAIT signal in a wire-ORed fashion with other internal and external peripherals. The /REQ component is routed to the DMA request multiplexing logic as described in a later section on the EMSCC.

Z80185 Parallel Ports

PIA16-14. *Port 1, Bits 6-4 or CTC ZC/TO2-0* (input/output). These lines can be configured as inputs or outputs, or as the "zero count/timeout" outputs of three of the four CTC channels, on a bit-by-bit basis.

PIA13-10. *Port 1, Bits 3-0 or CTC CLK/TRG3-0* (input/output). These lines can be configured as inputs or outputs, or as the "clock/trigger" inputs of the four CTC channels, on a bit-by-bit basis.

PIA27-20. *Port 2, Data, or Bidirectional* (input/output). These lines can be configured as inputs or outputs on a bit-by-bit basis when not used for Bidirectional Centronics operation. However, when used for Bidirectional Centronics operation, software and hardware controls the direction of all eight as a unit.

Bidirectional Centronics Pins

nStrobe, nAutoFd, nSelectIn, nInit (input/outputs). These are inputs when using P27-20 for the Peripheral side of a Centronics controller, or outputs when using P27-20 for the Host side of such an interface. In certain P1284 modes, these pins assume other names as described in the section on the Centronics P1284 controller. When not using P27-20 for a Centronics controller, these pins can be used as general-purpose inputs or outputs.

Busy, nAck, PError, nFault, Select (input/outputs). These are outputs when using P27-20 for the Peripheral side of a Centronics P1284 controller, or inputs when using P27-20 for the Host side of such an interface. In certain P1284 modes, these pins have other names as described in the section on the Centronics P1284 controller. When not using P27-20 for a Centronics P1284 controller, these pins can be used as general-purpose outputs or inputs. These pins always function in the opposite direction of the preceding group.

System Control Signals

ST. *Status* (output, active High). This signal is used with the /M1 and /HALT output to indicate the nature of each CPU machine cycle.

/RESET. *Reset Signal* (input, active Low). /RESET signal is used for initializing the Z80185 and other devices in the system. It must be kept Low for at least three system clock cycles.

IEI. *Interrupt Enable Signal* (input, active High). IEI is used with IEO to form a priority daisy-chain when there are external interrupt-driven Z80-compatible peripherals.

IEO. *Interrupt Enable Output Signal* (output, active High). In an interrupt daisy-chain, IEO controls the interrupt of external peripherals. IEO is active when IEI is 1 and the CPU is not servicing an interrupt from the on-chip peripherals.

/IOCS. /IOCS decodes /IORQ, /M1, and as many address lines as are necessary to ensure it is activated for an I/O space access to any register in any block of eight registers that does not contain any on-chip registers. Also included in the decode is any programmed relocation of the "180 register set" in the ICR, and the "Decode High I/O" bit in the System Configuration Register. If the "180 registers" aren't relocated, and "Decode High I/O" is 0, /IOCS is active from address XX40 through XXD7, XXF8 through XXFF, and NN00 through NN3F, where NN are non-zero. If the "180 registers" are not relocated and "Decode High I/O" is 1, /IOCS is active from 0040 through 00D7, and 00F8 through FFFF. /IOCS is active when an external master is in control of the bus, as well as when the Z80185 processor has control.

/RAMCS. *RAM Chip Select* (output, active Low). This signal is driven Low for memory accesses at addresses that fall between the values programmed into the RAMLBR and RAMUBR registers. It is active when an external master has control of the bus, as well as when the Z80185 processor is in control.

/ROMCS. *ROM Chip Select* (output, active Low). This output is driven Low for memory accesses between the top of on-chip ROM (if on-chip ROM is enabled) and the value programmed into the ROMBR register. It is active when an external master has control of the bus, as well as when the Z80185 processor is in control.

XTAL. *Crystal* (input, active High). This pin functions as the Crystal oscillator connection and should be left open if an external clock is used instead of a crystal. The oscillator input is not a TTL level (reference DC Characteristics section).

EXTAL. *External Clock/Crystal* (input, active High). This pin functions as a Crystal oscillator connection. An external clock can be input to the Z80185 on this pin when a crystal is not used. This input is Schmitt-triggered.

PHI. *System Clock* (output, active High). This output is the processor's reference clock, and is provided for the use of external logic. The frequency of this output may be equal to, or one-half that of the crystal or input clock frequency, depending on an internal register bit.

Z80185 MPU FUNCTIONAL DESCRIPTION

The Z80185 includes a Zilog Z8S180 MPU (Static Z80180 MPU). This allows software code compatibility with existing Z80/Z180 software code. The following is an overview of the major functional units of the Z80185.

The MPU portion of the Z80185 is the Z8S180 core with added features and modifications. The single-channel EMSCC of the Z80185 is compatible with the Z85233 EMSCC and features additional enhancements for LocalTalk and the demultiplexing of the /DTR//REQ and /WT//REQ lines.

Architecture

The Z80185 combines a high performance CPU core with a variety of system and I/O resources useful in a broad range of applications. The CPU core consists of four functional blocks:

- Clock Generator
- Bus State Controller (Dynamic Memory Refresh)
- Memory Management Unit (MMU)
- Central Processing Unit (CPU).

The integrated I/O resources make up the remaining functional blocks:

- Direct Memory Access (DMA control—two channels)
- Asynchronous Serial Communications Controller (ASCI, two channels)
- Programmable Reload Timers (PRT, two channels)
- Clocked Serial I/O
- Channel (CSIO)
- Enhanced Z85C30 (EMSCC)
- Counter/Timer Channels (CTC)
- Parallel I/O
- Bidirectional Centronics Controller.

Clock Generator. This logic generates the system clock from either an external crystal or clock input. The external clock is divided by two, or one if programmed, and is provided to both internal and external devices.

Bus State Controller. This logic performs all of the status and bus control activity associated with both the CPU and some on-chip peripherals. This includes wait state timing, reset cycles, DRAM refresh, and DMA bus exchanges.

Interrupt Controller. This logic monitors and prioritizes the variety of internal and external interrupts and traps to provide the correct responses from the CPU. To maintain compatibility with the Z80 CPU, three different interrupt modes are supported.

Memory Management Unit. The MMU allows the user to “map” the memory used by the CPU (logically only 64 Kbytes) into the 1 Mbyte addressing range supported by the Z80185. The organization of the MMU object code maintains compatibility with the Z80 CPU while offering access to an extended memory space. This is accomplished by using an effective “common area-banked area” scheme.

Central Processing Unit. The CPU is microcoded to provide a core that is object-code compatible with the Z80 CPU. It also provides a superset of the Z80 instruction set, including 8-bit multiply. This core has been modified to allow many of the instructions to execute in fewer clock cycles.

DMA Controller. The DMA controller provides high-speed transfers between memory and I/O devices. Transfer operations supported are memory-to-memory, memory to or from I/O, and I/O-to-I/O. Transfer modes supported are request, burst, and cycle steal. DMA transfers can access the full 1 Mbyte addressing range with a block length up to 64 Kbytes, and can cross over the 64 Kbytes boundaries.

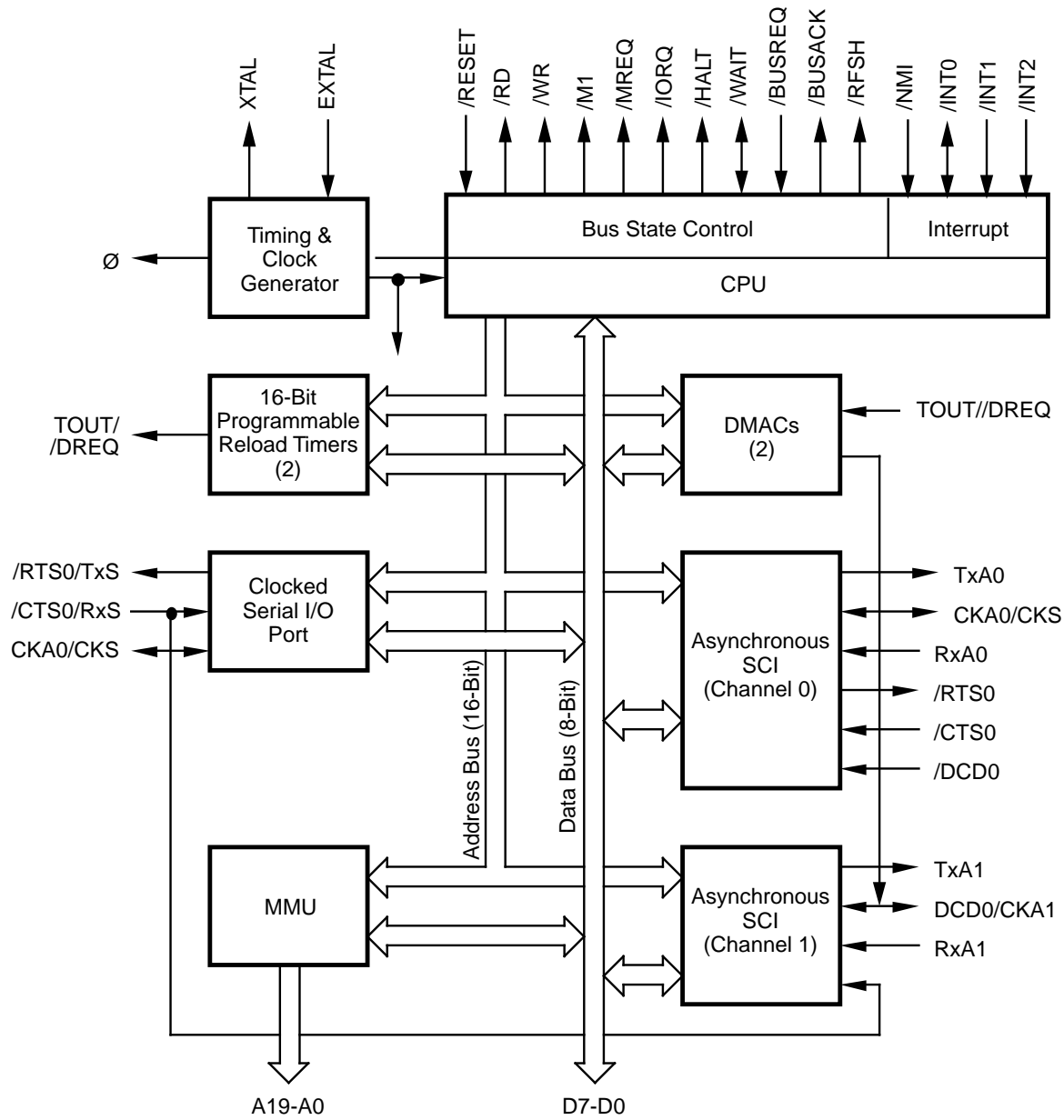

Figure 21. Z8S180 MPU Block Diagram

Z80185 MPU FUNCTIONAL DESCRIPTION (Continued)

DMA Controller

The two DMA channels of the Z80185 can transfer data to or from the EMSCC channel, the parallel interface, the async ports, or an external device. The I/O device encoding in SAR18-16 and DAR18-16 of the existing Z80180 is modified as shown in Table 1.

DMA request signals between the various cells are handled internally by the mechanisms described in this section, and are not pinned-out, nor are the TEND termination count outputs of the DMA channels.

Table 1. SAR18-16 and DAR18-16 I/O Device Encoding

SM1-0	SAR18-16	Source	DM1-0	DAR18-16	Destination
11	000	ext (TOUT/DREQ)	11	000	ext (TOUT/DREQ)
11	001	ASCII0 Rx	11	001	ASCII0 Tx
11	010	ASCII1 Rx	11	010	ASCII1 Tx
11	011	EMSCC Rx	11	011	EMSCC Tx
11	10X	Reserved, do not program.	11	10X	Reserved, do not program.
11	1X0		11	1X0	
11	111	PIA27-20 in	11	111	PIA27-20 out

Asynchronous Serial Communications Interface (ASCII)

The ASCII logic provides two individual full-duplex UARTs. Each channel includes a programmable baud rate generator and modem control signals. The ASCII channels can also support a multiprocessor communications format. For ASCII0, up to three modem control signals and one clock signal can be pinned out, while ASCII1 has a data-only interface.

During Reset and in I/O Stop state, and for ASCII0 if /DCD0 is auto-enabled and is High, an ASCII is forced to the following conditions:

- FIFO Empty
- All Error Bits Cleared (including those in the FIFO)
- Receive Enable Cleared (cntla bit 6 = 0)
- Transmit Enable Cleared (cntla bit 5 = 0).

The receiver includes a 4-byte FIFO, plus a shift register as shown in Figure 22.

If DCD is not auto-enabled, the /DCD pin has no effect on the FIFOs or enable bits.

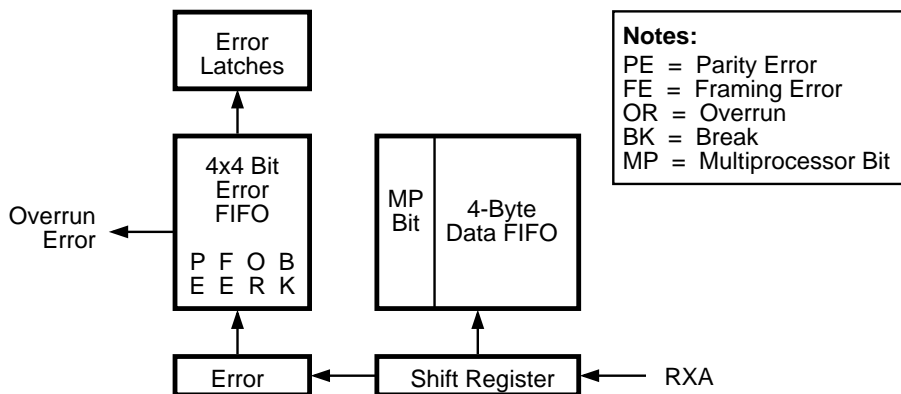

Figure 22. ASCII Receiver

FIFO and Receiver Operation

The 4-byte Receive FIFO is used to buffer incoming data to reduce the incidence of overrun errors. When the RE bit is set in the CNTLA register, the RXA pin is monitored for a Low transition. One-half bit time after the Low transition of the RXA pin, the ASCI samples RXA again. If it has gone back to High, the ASCI ignores the previous Low transition and resumes looking for a new one, but if RXA is still Low, it considers this a start bit and proceeds to clock in the data based upon the internal baud rate generator or the external CKA pin. The number of data bits, parity, multiprocessor and stop bits are selected by the MOD2, MOD1, MOD0 and MP bits in the CNTLA and CNTLB registers. After the data has been received the appropriate MP, parity and one stop bit are checked. Data and any errors are clocked into the FIFOs during the stop bit. Interrupts, Receive Data Register Full Flag, and DMA requests will also go active during this time.

Error Condition Handling

When the receiver places a data character in the Receive FIFO, it also places any associated error conditions in the error FIFO. The outputs of the error FIFO go to the set inputs of the software-accessible error latches. Writing a 0 to CNTLA EFR is the only way to clear these latches. In other words, when an error bit reaches the top of the FIFO, it sets an error latch. If the FIFO has more data and the software reads the next byte out of the FIFO, the error latch remains set, until the software writes a 0 to the EFR bit. The error bits are cumulative, so if additional errors are in the FIFO, they will set any unset error latches as they reach the top.

Overrun Error

An overrun occurs if the receive FIFO is full when the receiver has just assembled a byte in the shift register and is ready to transfer it to the FIFO. If this occurs, the overrun error bit associated with the previous byte in the FIFO is set. The latest data byte is not transferred from the shift register to the FIFO in this case, and is lost. Once an overrun occurs, the receiver does not place any further data in the FIFO, until the “last good byte received” has come to the top of the FIFO so that the Overrun latch is set, and software then clears the Overrun latch. Assembly of bytes continues in the shift register, but this data is ignored until the byte with the overrun error reaches the top of the FIFO and is cleared with a write of 0 to the EFR bit.

Break Detect

A Break is defined as a framing error with the data equal to all zeros. When a break occurs, the all-zero byte with its associated error bits are transferred to the FIFO, if it is not full. If the FIFO is full, an overrun is generated, but the break, framing error and data, are not transferred to the FIFO. Any time a break is detected, the receiver will not receive any more data until the RXA pin returns to a High state. If the channel is set in multiprocessor mode and the MPE bit of the CNTLA register is set to 1, then breaks, errors and data will be ignored unless the MP bit in the transmission is a 1. **Note:** The two conditions listed above could cause a break condition to be missed if the FIFO is full and the break occurs, or if the MP bit in the transmission is not a 1 with the conditions specified above.

Parity and Framing Errors

Parity and Framing Errors do not affect subsequent receiver operation.

Z80185 MPU FUNCTIONAL DESCRIPTION (Continued)**Baud Rate Generator**

The Baud Rate Generator (BRG) has two modes. The first is the same as in the Z80180. The second is a 16-bit down counter that divides the processor clock by the value in a 16-bit time constant register, and is identical to the EMSCC BRG. This allows a common baud rate of up to 512 Kbps to be selected. The BRG can also be disabled in favor of an external clock on the CKA pin.

The Receiver and Transmitter will subsequently divide the output of the BRG (or the signal from the CKA pin) by 1, 16 or 64, under the control of the DR bit in the CNTLB register, and the X1 bit in the ASCI Extension Control Register. To compute baud rate, use the following formulas.

If $ss2,1,0 = 111$, baud rate = $f_{CKA} / \text{Clock mode}$

else if BRG mode baud rate = $f_{PHI} / (2 * (TC+2) * \text{Clock mode})$

else baud rate = $f_{PHI} / ((10 + 20*PS) * 2^{ss} * \text{Clock mode})$

Where:

BRG mode is bit 3 of the ASEXT register

PS is bit 5 of the CNTLB register

TC is the 16-bit value in the ASCI Time Constant registers
The TC value for a given baud rate is:

$TC = (f_{PHI} / (2 * \text{baud rate} * \text{Clock mode})) - 2$

Clock mode depends on bit 4 in ASEXT and bit 3 in CNTLB:

X1	DR		Clock Mode
0	0	=	16
0	1	=	64
1	0	=	1
1	1	=	Reserved, do not use.

2^{ss} depends on the three LS bits of the CNTLB register:

ss2	ss1	ss0	2^{ss}
0	0	0	= 1
0	0	1	= 2
0	1	0	= 4
0	1	1	= 8
1	0	0	= 16
1	0	1	= 32
1	1	0	= 64
1	1	1	= External Clock from CKA0 (see above).

The ASCIs require a 50 percent duty cycle when CKA is used as an input. Minimum High and Low times on CKA0 are typical of most CMOS devices.

RDRF is set, and if enabled an Rx Interrupt or DMA Request is generated, when the receiver transfers a character from the Rx Shift Register to the Rx FIFO. The FIFO merely provides margin against overruns. When there's more than one character in the FIFO, and software or a DMA channel reads a character, RDRF either remains set or is cleared and then immediately set again. For example, if a receive interrupt service routine doesn't read all the characters in the Rx FIFO, RDRF and the interrupt request remain asserted.

The Rx DMA request is disabled when any of the error flags PE or FE or OVRN are set, so that software can identify with which character the problem is associated.

If Bit 7, RDRF Interrupt Inhibit, is set to 1 (see Figures 32 and 33), the ASCI does not request a Receive interrupt when its RDRF flag is 1. Set this bit when programming a DMA channel to handle the receive data from an ASCI. The other causes for an ASCI Receive interrupt (PE, FE, OVRN, and for ASCI0, DCD) continue to request Rx interrupt if the RIE bit is 1. (The Rx DMA request is inhibited if PE or FE or OVRN is set, so that software can tell where an error occurred.) When this bit is 0, as it is after a Reset, RDRF will cause an ASCI interrupt if RIE is 1.

Programmable Reload Timer (PRT)

This logic consists of two separate channels, each containing a 16-bit counter (timer) and count reload register. The time base for the counters is derived from the system clock (divided by 20) before reaching the counter. PRT channel 1 provides an optional output to allow for waveform generation.

The T_{OUT} output of PRT1 is available on a multiplexed pin.

Clocked Serial I/O (CSIO)

The pins for this function are multiplexed with the RTS, CTS, and clock pins for ASCI0. **Note:** It is possible to use both ASCI0 and the CSIO at the same time. If bit 4 of the System Configuration Register is set to 1, the CKS clock signal will internally drive the clock for ASCI0 instead of the system clock.

/M1

The /M1 generation logic of the Z80180 allows the use of logic analyzer disassemblers that rely on /M1 identifying the start of each instruction. If the MIE bit is set to 1, the processor does not refetch an RETI instruction.

Z80185 Counter/Timers

These facilities include two 16-bit Programmable Reload Timers (PRTs) like those provided in the Z80180 and its successors, plus four CTC channels like those in the Z84C30. The TOUT output of PRT1 is output on a multiplexed pin, and the ZC/TO outputs and CLK/TRG inputs of the CTC's are multiplexed with PIA17-10 on an individual basis, rather than simultaneously as on the Z80181. Internal cascading is provided between the CTCs, as described in CTC Control section.

Z80185 I/O Chip Select

This output is active when an external master has control of the bus, as well as when the Z80185 processor has control. The /IOCS output of the Z80185 operates correctly if the "180 registers" are relocated to I/O address 40-7F or 80-BF, and takes into account the "Decode High I/O" bit in the Z80185 System Configuration Register.

32K x 8 On-Chip Read-Only Memory (ROM)

The Z80185 processor features 32K x 8 of masked ROM. This on-chip ROM allows zero-wait-state generation at the maximum clock rate. The Z80195 processor is ROMless.

Z80185 On-Chip ROM Enable/Disable

If /WAIT is Low at the rising edge of /RESET, the on-chip program memory is disabled and all accesses to addresses below the upper limit of /ROMCS go off-chip. This feature allows code development and emulation using external devices before the user is ready to use on-chip memory.

If /WAIT is High at the rising edge of /RESET, accesses to addresses below both the size of on-chip ROM and the upper limit of /ROMCS, the user should select on-chip ROM. Accesses that are above the size of the on-chip ROM, but below the upper limit of /ROMCS, go off-chip with /ROMCS asserted.

Table 2. Power Down Modes

Power-Down Modes	CPU Core	On-Chip I/O	OSC.	CLKOUT	Recovery Source	Recovery Time (Minimum)
SLEEP	Stop	Running	Running	Running	RESET, Interrupts	1.5 Clock
I/O STOP	Running	Stop	Running	Running	By Programming	-
SYSTEM STOP	Stop	Stop	Running	Running	RESET, Interrupts	1.5 Clock
IDLE [†]	Stop	Stop	Running	Stop	RESET, Interrupts, BUSREQ	8 +1.5 Clock
STANDBY [†]	Stop	Stop	Stop	Stop	RESET, Interrupts, BUSREQ	2 ¹⁷ +1.5 Clock (Normal Recovery) 2 ⁶ +1.5 Clock (Quick Recovery)

Z8S180 POWER-DOWN MODES

The following is a detailed description of the enhancements to the Z8S180 from the standard Z80180 in the areas of STANDBY, IDLE, and STANDBY-QUICK RECOVERY modes.

Add-On Features

There are five different power-down modes. SLEEP and SYSTEM STOP are inherited from the Z80180. In SLEEP

Notes:

† IDLE and STANDBY modes are only offered in the Z8S180. Note that the minimum recovery time can be achieved if INTERRUPT is used as the Recovery Source.

mode, the CPU is in a stopped state while the on-chip I/Os are still operating. In I/O STOP mode, the on-chip I/Os are in a stopped state while leaving the CPU running. In SYSTEM STOP mode, both the CPU and the on-chip I/Os are in the stopped state to reduce current consumption. The Z8S180 has added two additional power-down modes, STANDBY and IDLE, to reduce current consumption even further. The differences in these power-down modes are summarized in Table 2.

STANDBY Mode

The Z8S180 is designed to save power. Two low-power programmable power-down modes have been added: STANDBY mode and IDLE mode. The STANDBY/IDLE mode is selected by multiplexing D6 and D3 of the CPU Control Register (CCR, I/O Address = 1FH).

To enter STANDBY mode:

1. Set D6 and D3 to 1 and 0, respectively.
2. Set the I/O STOP bit (D5 of ICR, I/O Address = 3FH) to 1.
3. Execute the SLEEP instruction.

When the device is in STANDBY mode, it behaves similar to the SYSTEM STOP mode as it exists on the Z80180, except that the STANDBY mode stops the external oscillator, internal clocks and reduces power consumption to 50 μ A (typical).

Since the clock oscillator has been stopped, a restart of the oscillator requires a period of time for stabilization. An 18-bit counter has been added in the Z8S180 to allow for

oscillator stabilization. When the part receives an external IRQ or BUSREQ during STANDBY mode, the oscillator is restarted and the timer counts down 2^{17} counts before acknowledgment is sent to the interrupt source.

The recovery source needs to remain asserted for the duration of the 2^{17} count, otherwise standby will be re-

STANDBY Mode Exit with BUS REQUEST

Optionally, if the BREXT bit (D5 of CPU Control Register) is set to 1, the Z8S180 exits STANDBY mode when the /BUSREQ input is asserted; the crystal oscillator is then restarted. An internal counter automatically provides time for the oscillator to stabilize, before the internal clocking and the system clock output of the Z8S180 are resumed.

The Z8S180 relinquishes the system bus after the clocking is resumed by:

- Tri-State the address outputs A19 through A0.
- Tri-State the bus control outputs /MREQ, /IORQ, /RD and /WR.
- Asserting /BUSACK

The Z8S180 regains the system bus when /BUSREQ is deactivated. The address outputs and the bus control outputs are then driven High; the STANDBY mode is exited.

If the BREXT bit of the CPU Control Register (CCR) is cleared, asserting the /BUSREQ will not cause the Z8S180 to exit STANDBY mode.

If STANDBY mode is exited due to a reset or an external interrupt, the Z8S180 remains relinquished from the system bus as long as /BUSREQ is active.

STANDBY Mode Exit with External Interrupts

STANDBY mode can be exited by asserting input /NMI. The STANDBY mode may also exit by asserting /INT0, /INT1 or /INT2, depending on the conditions specified in the following paragraphs.

/INT0 wake-up requires assertion throughout duration of clock stabilization time (2^{17} clocks).

If exit conditions are met, the internal counter provides time for the crystal oscillator to stabilize, before the internal clocking and the system clock output within the Z8S180 are resumed.

1. Exit with Non-Maskable Interrupts

If /NMI is asserted, the CPU begins a normal NMI interrupt acknowledge sequence after clocking resumes.

2. Exit with External Maskable Interrupts

If an External Maskable Interrupt input is asserted, the CPU responds according to the status of the Global Interrupt Enable Flag IEF1 (determined by the ITE1 bit) and the settings of the corresponding interrupt enable bit in the Interrupt/Trap Control Register (ITC: I/O Address = 34H):

- a. If an interrupt source is disabled in the ITC, asserting the corresponding interrupt input will not cause the Z8S180 to exit STANDBY mode. This is true regardless of the state of the Global Interrupt Enable Flag IEF1.
- b. If the Global Interrupt Flag IEF1 is set to 1, and if an interrupt source is enabled in the ITC, asserting the corresponding interrupt input causes the Z8S180 to exit STANDBY mode. The CPU performs an interrupt acknowledge sequence appropriate to the input being asserted when clocking is resumed if:
 - The interrupt input follows the normal interrupt daisy-chain protocol.
 - The interrupt source is active until the acknowledge cycle is completed.
- c. If the Global Interrupt Flag IEF1 is disabled, in other words, reset to 0, and if an interrupt source is enabled in the ITC, asserting the corresponding interrupt input will still cause the Z8S180 to exit STANDBY mode. The CPU will proceed to fetch and execute instructions that follow the SLEEP instruction when clocking is resumed.

If the External Maskable Interrupt input is not active until clocking resumes, the Z8S180 will not exit STANDBY mode. If the Non-Maskable Interrupt (/NMI) is not active until clocking resumes, the Z8S180 still exits the STANDBY mode even if the interrupt sources go away before the timer times out, because /NMI is edge-triggered. The condition is latched internally once /NMI is asserted Low.

IDLE Mode

IDLE mode is another power-down mode offered by the Z8S180. To enter IDLE mode:

1. Set D6 and D3 to 0 and 1, respectively.
2. Set the I/O STOP bit (D5 of ICR, I/O Address = 3FH) to 1.
3. Execute the SLEEP instruction.

When the part is in IDLE mode, the clock oscillator is kept oscillating, but the clock to the rest of the internal circuit, including the CLKOUT, is stopped completely. IDLE mode is exited in a similar way as STANDBY mode, in other words, RESET, BUS REQUEST or EXTERNAL INTERRUPTS, except that the 2^{17} bit wake-up timer is bypassed; all control signals are asserted eight clock cycles after the exit conditions are gathered.

Standby-Quick Recovery Mode

STANDBY-QUICK RECOVERY mode is an option offered in STANDBY mode to reduce the clock recovery time in STANDBY mode from 2^{17} clock cycles (6.5 ms at 20 MHz) to 2^6 clock cycles (3.2 μ s at 20 MHz). This feature can only be used when providing an oscillator as clock source.

To enter STANDBY-QUICK RECOVERY mode:

1. Set D6 and D3 to 1 and 1, respectively.
2. Set the I/O STOP bit (D5 of ICR, I/O Address = 3FH) to 1.
3. Execute the SLEEP instruction.

When the part is in STANDBY-QUICK RECOVERY mode, the operation is identical to STANDBY mode except when exit conditions are gathered, in other words, RESET, BUS REQUEST or EXTERNAL INTERRUPTS. The clock and other control signals are recovered sooner than the STANDBY mode.

Note: If STANDBY-QUICK RECOVERY is enabled, the user must make sure stable oscillation is obtained within 64 clock cycles.

Z8S180 MPU REGISTER MAP

Notes:

Registers listed in **boldface type** represent new registers added to the Z8S180.

All register addresses not listed are Reserved.

Register Name	I/O Addr/Access	Register Name	I/O Addr/Access
ASCI Control Register A Ch 0	%0000/40/80 R/W	CPU Control Register	%001F/5F/9F R/W
ASCI Control Register A Ch 1	%0001/41/81 R/W	DMA Source Addr Register Ch OL	%0020/60/A0 R/W
ASCI Control Register B Ch 0	%0002/42/82 R/W	DMA Source Addr Register Ch OH	%0021/61/A1 R/W
ASCI Control Register B Ch 1	%0003/43/83 R/W	DMA Source Addr Register Ch OB	%0022/62/A2 R/W
ASCI Status Register Ch 0	%0004/44/84 R/W	DMA Dest Addr Register Ch OL	%0023/63/A3 R/W
ASCI Status Register Ch 1	%0005/45/85 R/W	DMA Dest Addr Register Ch OH	%0024/64/A4 R/W
ASCI TX Data Register Ch 0	%0006/46/86 R/W	DMA Dest Addr Register Ch OB	%0025/65/A5 R/W
ASCI TX Data Register Ch 1	%0007/47/87 R/W	DMA Byte Count Register Ch OL	%0026/66/A6 R/W
ASCI RX Data Register Ch 0	%0008/48/88 R/W	DMA Byte Count Register Ch OH	%0027/67/A7 R/W
ASCI RX Data Register Ch 1	%0009/49/89 R/W	DMA Memory Addr Register Ch 1L	%0028/68/A8 R/W
CSIO Control Register	%000A/4A/8A R/W	DMA Memory Addr Register Ch 1H	%0029/69/A9 R/W
CSIO Transmit/Receive Data Reg.	%000B/4B/8B R/W	DMA Memory Addr Register Ch 1B	%002A/6A/AA R/W
Timer Data Register Ch OL	%000C/4C/8C R/W	DMA I/O Addr Register Ch 1L	%002B/6B/AB R/W
Timer Data Register Ch OH	%000D/4D/8D R/W	DMA I/O Addr Register Ch 1H	%002C/6C/AC R/W
Reload Register Ch OL	%000E/4E/8E R/W	DMA I/O Addr Register Ch 1B	%002D/6D/ADR/W
Reload Register Ch OH	%000F/4F/8F R/W	DMA Byte Count Register Ch 1L	%002E/6E/AE R/W
Timer Control Register	%0010/50/90	DMA Byte Count Register Ch 1H	%002F/6F/AF R/W
ASCI0 Extension Control Reg.	%0012/52/92 R/W	DMA Status Register	%0030/70/B0 R/W
ASCI1 Extension Control Reg.	%0013/53/93 R/W	DMA Mode Register	%0031/71/B1 R/W
Timer Data Register Ch 1L	%0014/54/94 R/W	DMA/WAIT Control Register	%0032/72/B2 R/W
Timer Data Register Ch 1H	%0015/55/95 R/W	IL Register	%0033/73/B3 R/W
Timer Reload Register Ch 1L	%0016/56/96 R/W	INT/TRAP Control Register	%0034/74/B4 R/W
Timer Reload Register Ch 1H	%0017/57/97 R/W	Refresh Control Register	%0036/76/B6 R/W
Free Running Counter	%0018/58/98 R/W	MMU Common Base Register	%0038/78/B8 R/W
ASCI0 Time Constant Low	%001A/5A/9A R/W	MMU Bank Base Register	%0039/79/B9 R/W
ASCI0 Time Constant High	%001B/5B/9B R/W	MMU Common/Bank Area Register	%003A/7A/BA R/W
ASCI1 Time Constant Low	%001C/5C/9C R/W	Operation Mode Control Register	%003E/7E/BE R/W
ASCI1 Time Constant High	%001D/5D/9D RW	I/O Control Register	%003F/7F/BF R/W

Z8S180 MPU REGISTERS

ASCII CHANNELS CONTROL REGISTERS

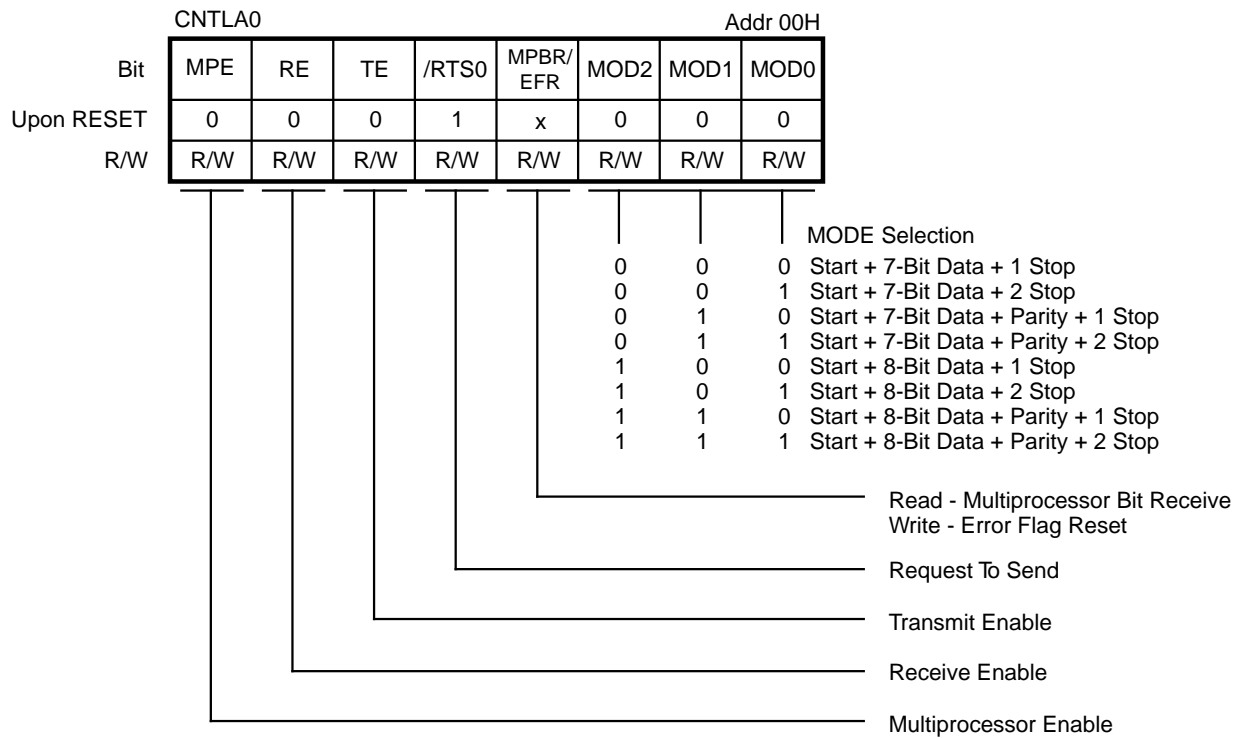

Figure 23a. ASCII Control Register A (Ch. 0)

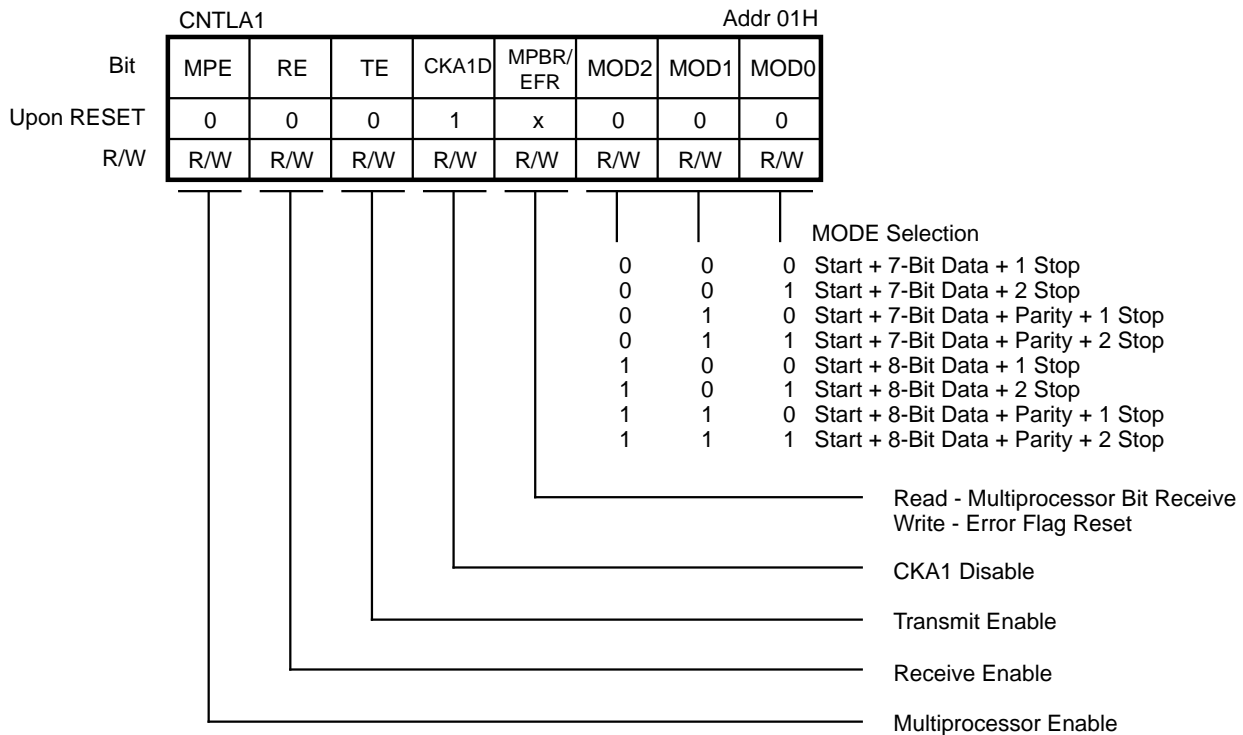
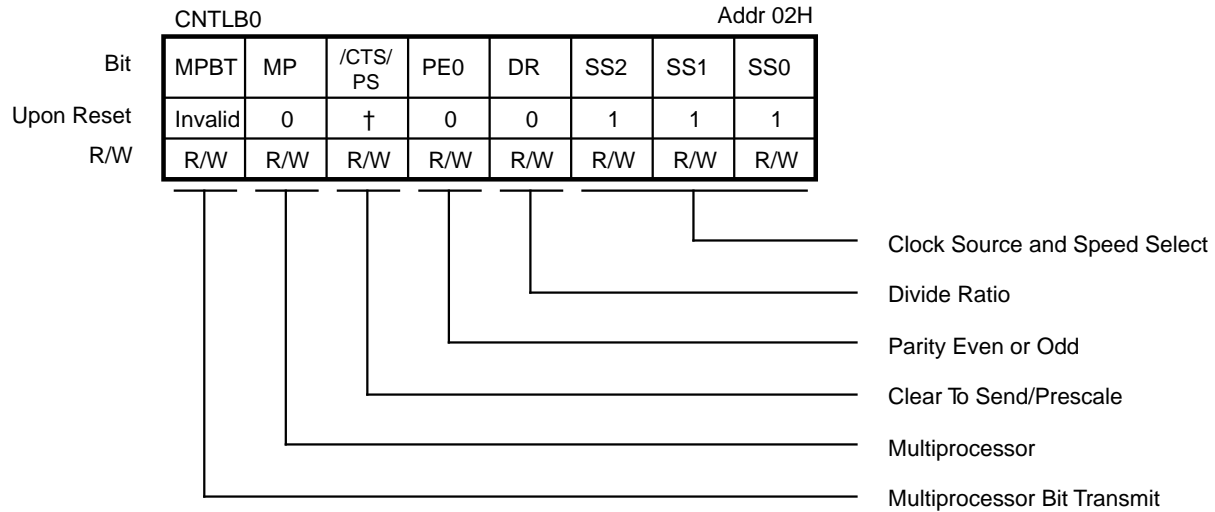

Figure 23b. ASCII Control Register A (Ch. 1)



† /CTS - Depending on the condition of /CTS pin.
PS - Cleared to 0.

General Divide Ratio	PS = 0 (Divide Ratio = 10)	PS = 1 (Divide Ratio = 30)		
SS, 2, 1, 0	DR = 0 (x16)	DR = 1 (x64)	DR = 0 (x16)	DR = 1 (x64)
000	$\emptyset \div 160$	$\emptyset \div 640$	$\emptyset \div 480$	$\emptyset \div 1920$
001	$\emptyset \div 320$	$\emptyset \div 1280$	$\emptyset \div 960$	$\emptyset \div 3840$
010	$\emptyset \div 640$	$\emptyset \div 2560$	$\emptyset \div 1920$	$\emptyset \div 7680$
011	$\emptyset \div 1280$	$\emptyset \div 5120$	$\emptyset \div 3840$	$\emptyset \div 15360$
100	$\emptyset \div 2560$	$\emptyset \div 10240$	$\emptyset \div 7680$	$\emptyset \div 30720$
101	$\emptyset \div 5120$	$\emptyset \div 20480$	$\emptyset \div 15360$	$\emptyset \div 61440$
110	$\emptyset \div 10240$	$\emptyset \div 40960$	$\emptyset \div 30720$	$\emptyset \div 122880$
111	External Clock (Frequency < \emptyset)			

Figure 24. ASCII Control Register B (Ch. 0)

ASCII CHANNELS CONTROL REGISTERS (Continued)

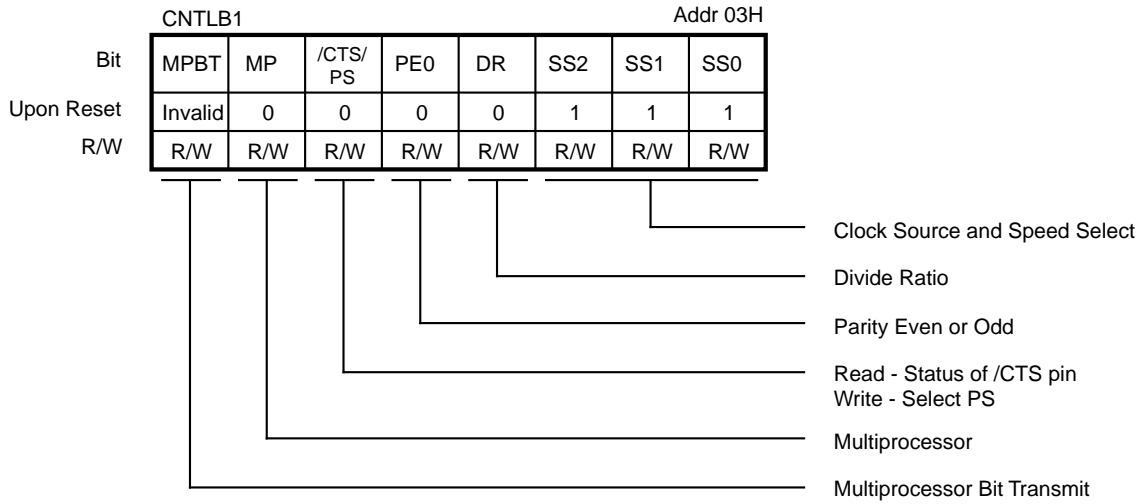

General Divide Ratio SS, 2, 1, 0	PS = 0 (Divide Ratio = 10)		PS = 1 (Divide Ratio = 30)	
	DR = 0 (x16)	DR = 1 (x64)	DR = 0 (x16)	DR = 1 (x64)
000	$\emptyset \div 160$	$\emptyset \div 640$	$\emptyset \div 480$	$\emptyset \div 1920$
001	$\emptyset \div 320$	$\emptyset \div 1280$	$\emptyset \div 960$	$\emptyset \div 3840$
010	$\emptyset \div 640$	$\emptyset \div 2560$	$\emptyset \div 1920$	$\emptyset \div 7680$
011	$\emptyset \div 1280$	$\emptyset \div 5120$	$\emptyset \div 3840$	$\emptyset \div 15360$
100	$\emptyset \div 2560$	$\emptyset \div 10240$	$\emptyset \div 7680$	$\emptyset \div 30720$
101	$\emptyset \div 5120$	$\emptyset \div 20480$	$\emptyset \div 15360$	$\emptyset \div 61440$
110	$\emptyset \div 10240$	$\emptyset \div 40960$	$\emptyset \div 30720$	$\emptyset \div 122880$
111	External Clock (Frequency < \emptyset)			

Figure 25. ASCII Control Register B (Ch. 1)

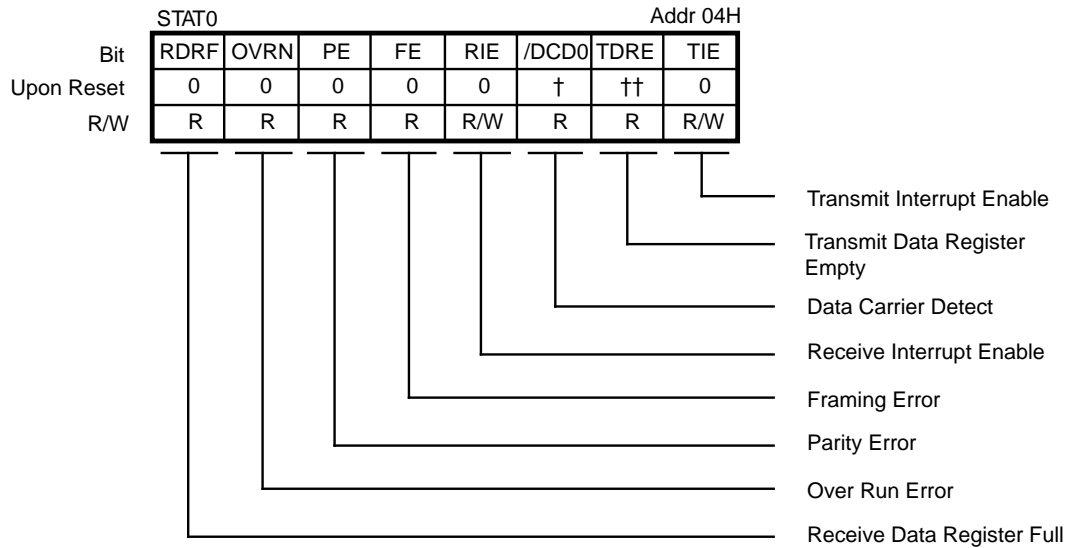

† /DCD0 - Depending on the condition of /DCD0 Pin.

†† /CTS0 Pin	TDRE
L	1
H	0

Figure 26. ASCI Status Register (Ch. 0)

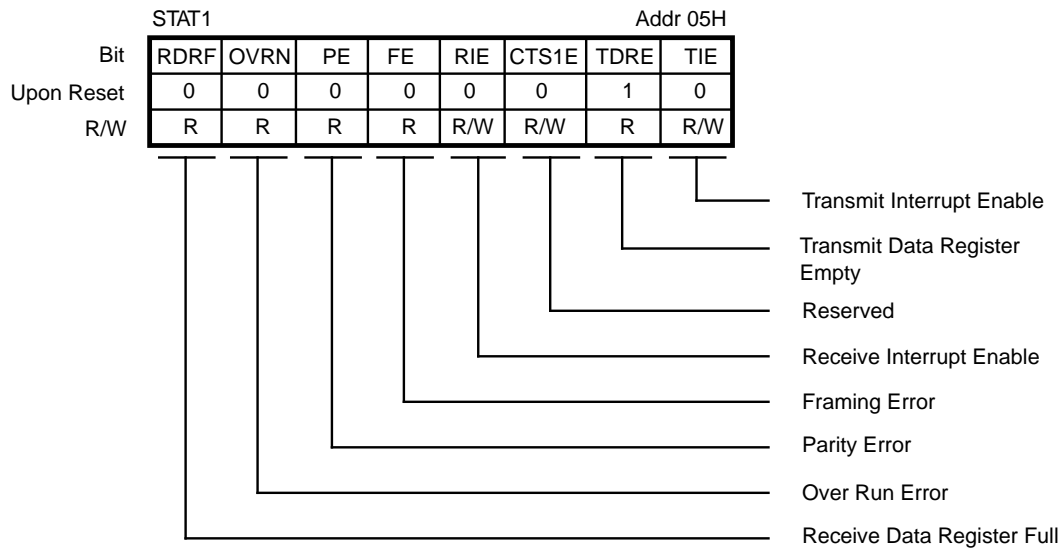

Figure 27. ASCI Status Register (Ch. 1)

ASCII CHANNELS CONTROL REGISTERS (Continued)

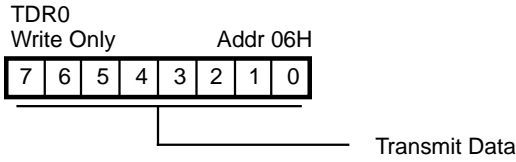

Figure 28. ASCII Transmit Data Register (Ch. 0)

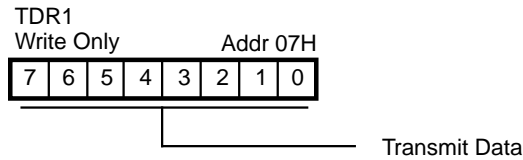

Figure 29. ASCII Transmit Data Register (Ch. 1)

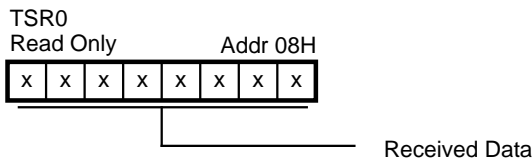

Figure 30. ASCII Receive Data Register (Ch. 0)

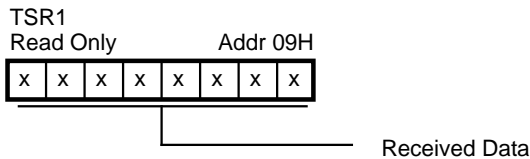

Figure 31. ASCII Receive Data Register (Ch. 1)

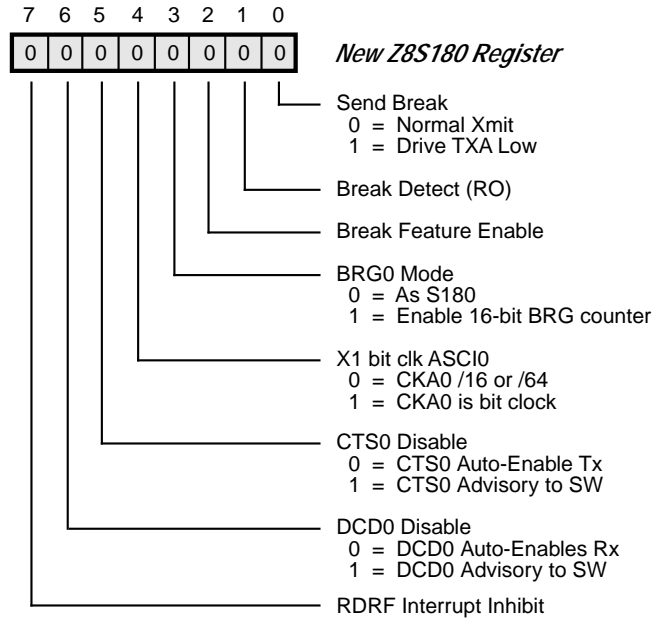

Figure 32. ASCII0 Extension Control Register
(I/O Address 12)

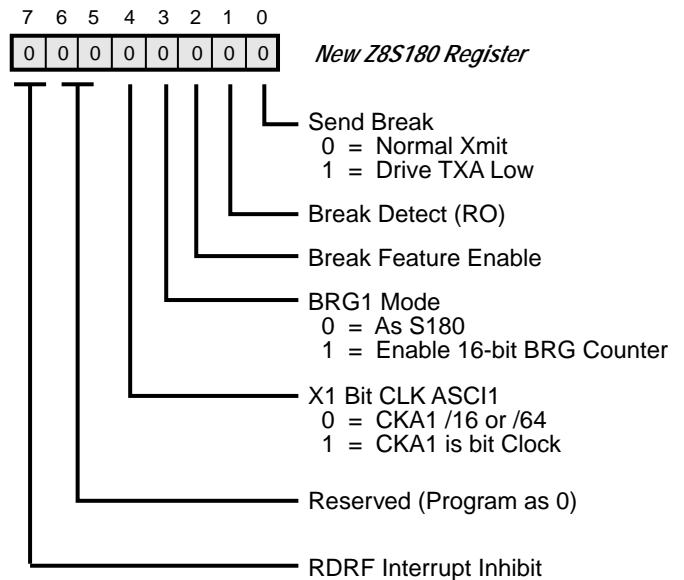
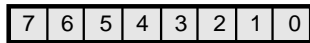

Figure 33. ASCII1 Extension Control Register
(I/O Address 13)

ACSI TIME CONSTANT REGISTERS

New Z8S180 Registers



Register: ASCI0 Time Constant Low
Address: 1Ah

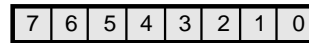

Register: ASCI1 Time Constant Low
Address: 1Ch

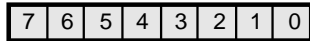

Register: ASCI0 Time Constant High
Address: 1Bh

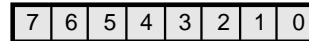

Register: ASCI1 Time Constant High
Address: 1Dh

CSI/O REGISTERS

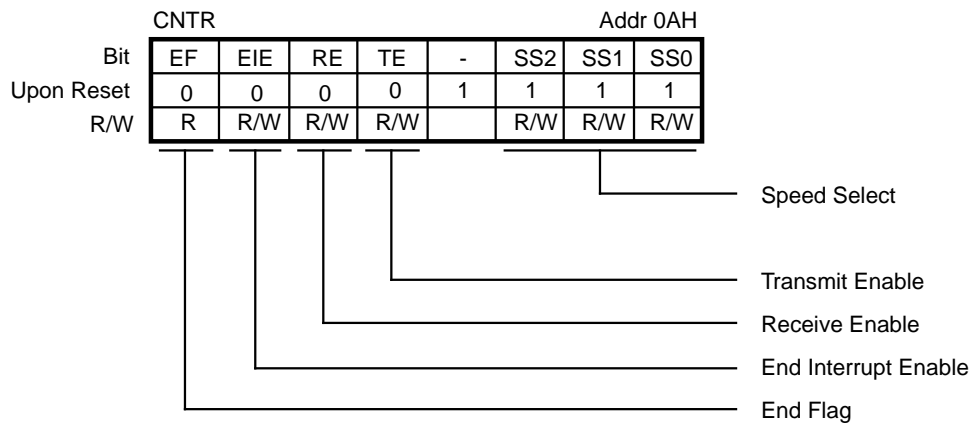

SS2, 1, 0	Baud Rate
000	$\emptyset \div 20$
001	$\emptyset \div 40$
010	$\emptyset \div 80$
011	$\emptyset \div 100$

SS2, 1, 0	Baud Rate
100	$\emptyset \div 320$
101	$\emptyset \div 640$
110	$\emptyset \div 1280$
111	External Clock (Frequency < $\emptyset \div 20$)

Figure 34. CSI/O Control Register

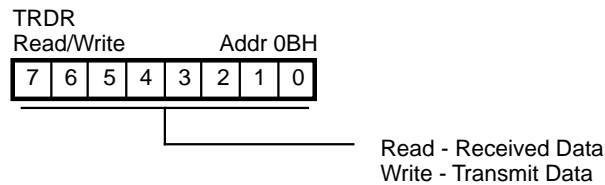

Figure 35. CSI/O Transmit/Receive Data Register

TIMER DATA REGISTERS

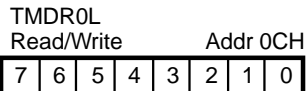
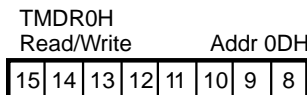

Figure 36. Timer 0 Data Register L



When Read, read Data Register L before reading Data Register H.

Figure 38. Timer 0 Data Register H

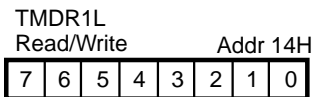
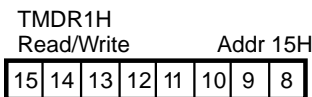

Figure 37. Timer 1 Data Register L



When Read, read Data Register L before reading Data Register H.

Figure 39. Timer 1 Data Register H

TIMER RELOAD REGISTERS

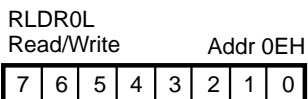

Figure 40. Timer 0 Reload Register L

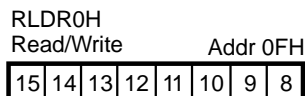

Figure 42. Timer 0 Reload Register H

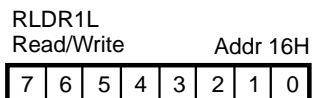

Figure 41. Timer 1 Reload Register L

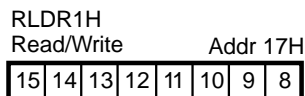

Figure 43. Timer 1 Reload Register H

TIMER CONTROL REGISTER

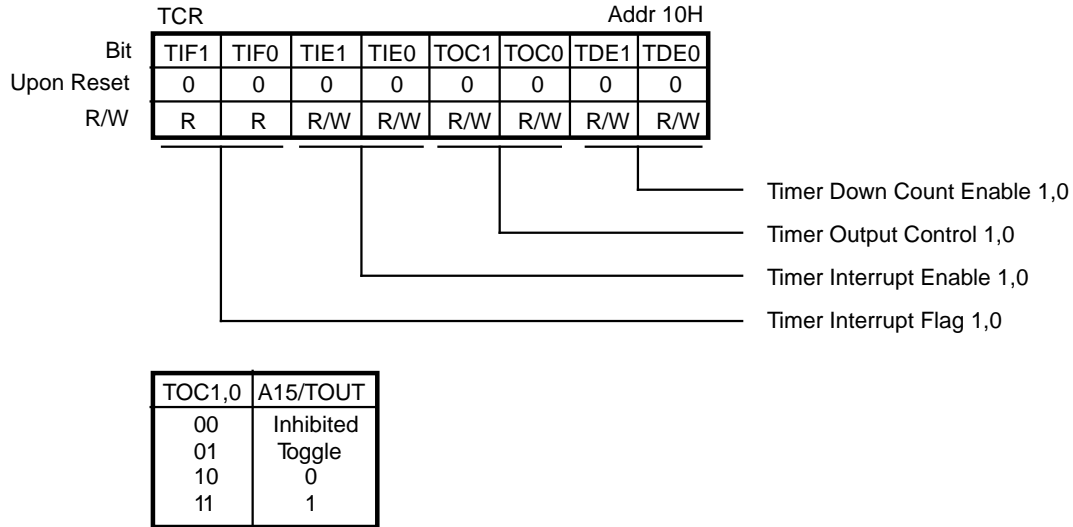

Figure 44. Timer Control Register

FREE RUNNING COUNTER

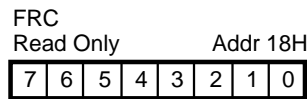

Figure 45. Free Running Counter

CPU CONTROL REGISTER

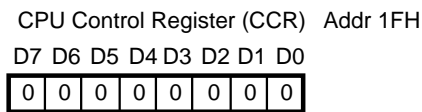
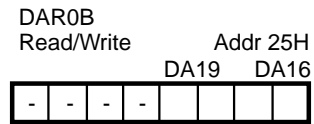
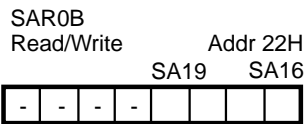
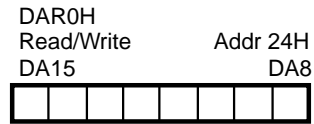
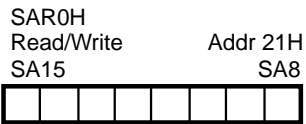
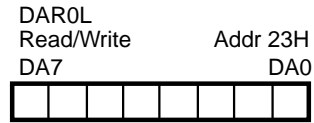
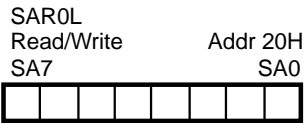

Figure 46. CPU Control Register
Note: See Figure 87 for full description.

DMA REGISTERS



Bits 0-3 are used for SAR0B

SM1-0	SAR18-16	Source
11	000	ext (TOUT/DREQ)
11	001	ASC10 Rx
11	010	ASC11 Rx
11	011	ESCC Rx
11	111	PIA27-20 IN

Bits 0-3 are used for DAR0B

DM1-0	DAR18-16	Destination
11	000	ext (TOUT/DREQ)
11	001	ASC10 Tx
11	010	ASC11 Tx
11	011	ESCC Tx
11	111	PIA27-20 OUT

Figure 47. DMA 0 Source Address Registers

Figure 48. DMA 0 Destination Address Registers

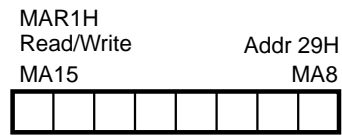
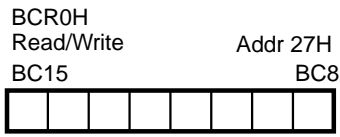
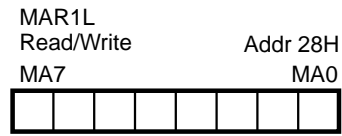
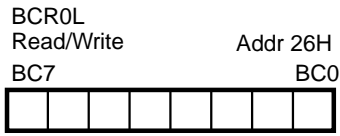

Figure 49. DMA 0 Byte Counter Registers

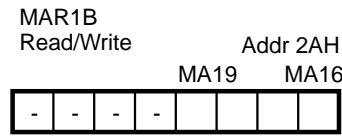

Figure 50. DMA 1 Memory Address Registers

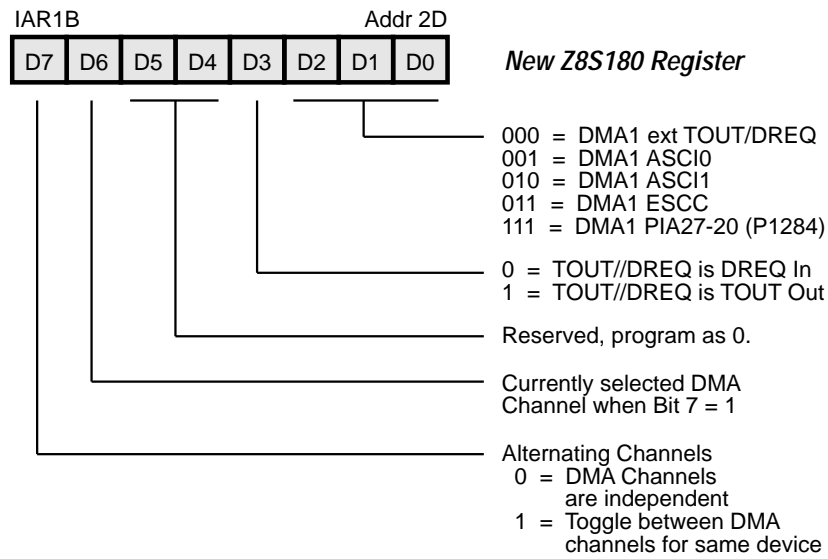

Figure 51. DMA I/O Address Register Ch. 1

DMA REGISTER DESCRIPTION

Bit 7. This bit should be set to 1 only when both DMA channels are set to take their requests from the same device. If this bit is 1 (it resets to 0), the channel end output of DMA channel 0 sets a flip-flop, so that thereafter the device's request is visible to channel 1, but is not visible to channel 0. The channel end output of channel 1 clears the FF, so that thereafter, the device's request is visible to channel 0, but not visible to channel 1.

Bit 6. When both DMA channels are programmed to take their requests from the same device, this bit (FF mentioned in the previous paragraph) controls which channel the device's request is presented to: 0 = DMA 0, 1 = channel 1. When bit 7 is 1, this bit is automatically toggled by the channel end output of the channels, as described above.

Bits 5-4. Reserved and should be programmed as 0.

Bits 3. This bit controls the direction and use of the TOUT/DREQ pin. When it's 0, TOUT/DREQ is the DREQ input; when it's 1, TOUT/DREQ is an output that can carry the TOUT signal from PRT1, if PRT1 is so programmed.

Bits 2-0. With "DIM1", bit 1 of DCNTL, these bits control which request is presented to DMA channel 1, as follows:

DIM1	IAR18-16	Request Routed to DMA Channel 1
0	000	ext TOUT/DREQ
0	001	ASCI0 Tx
0	010	ASCI1 Tx
0	011	EMSCC out
0	10X	Reserved, do not program.
0	1X0	Reserved, do not program.
0	111	PIA27-20 out
1	000	ext TOUT/DREQ
1	001	ASCI0 Rx
1	010	ASCI1 Rx or TOUT//DREQ pin
1	011	EMSCC in
1	10X	Reserved, do not program.
1	1X0	Reserved, do not program.
1	111	PIA27-20 in

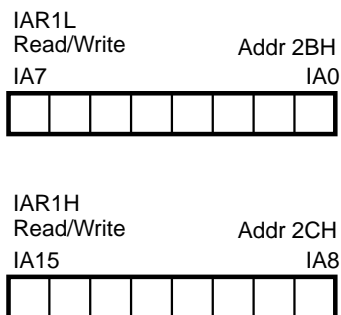

Figure 52. DMA I/O Address Registers

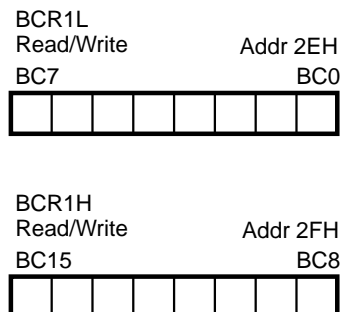

Figure 53. DMA 1 Byte Count Registers

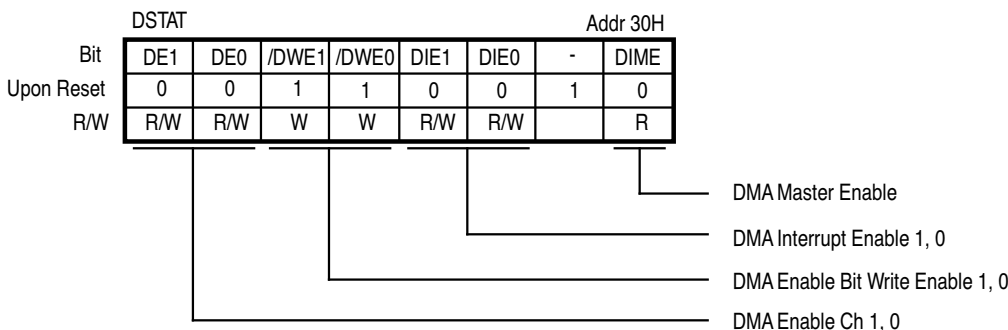
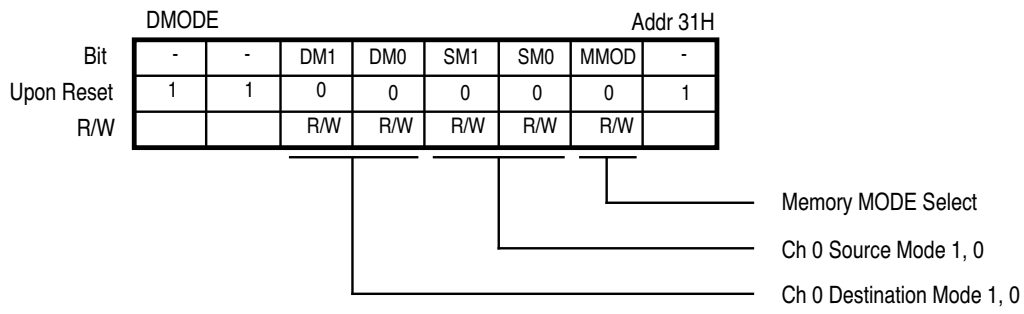

Figure 54. DMA Status Register

DMA REGISTERS (Continued)



DM1, 0	Destination	Address
00	M	DAR0+1
01	M	DAR0-1
10	M	DAR0 Fixed
11	I/O	DAR0 Fixed

SM1, 0	Source	Address
00	M	SAR0+1
01	M	SAR0-1
10	M	SAR0 Fixed
11	I/O	SAR0 Fixed

MMOD	Mode
0	Cycle Steal Mode
1	Burst Mode

Figure 55. DMA Mode Registers

DMA REGISTERS (Continued)

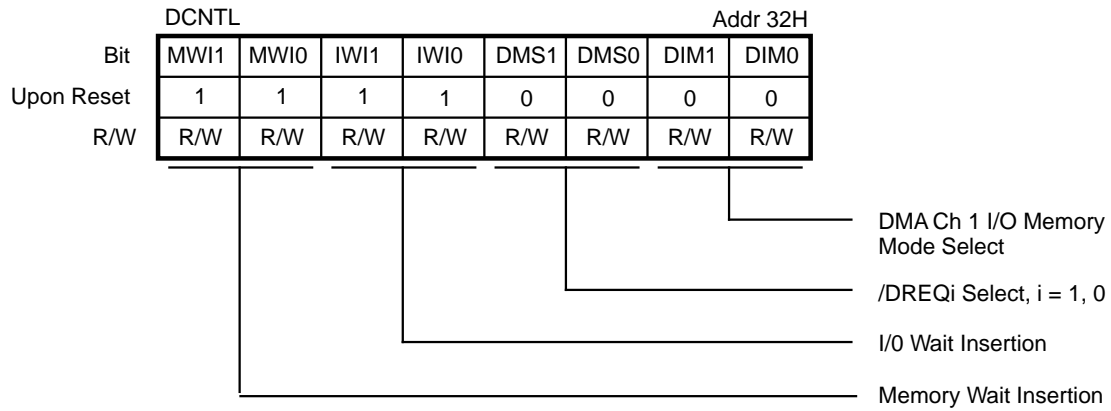

*

MW11, 0	No. of Wait States
00	0
01	1
10	2
11	3

IW11, 0	No. of Wait States
00	1
01	2
10	3
11	4

DMSi	Sense
1	Edge Sense
0	Level Sense

DM1, 0	Transfer Mode	Address Increment/Decrement	
00	M - I/O	MAR1+1	IAR1 Fixed
01	M - I/O	MAR1-1	IAR1 Fixed
10	I/O - M	IAR1 Fixed	MAR1+1
11	I/O - M	IAR1 Fixed	MAR1-1

Note:
* If using the Wait-State Generators provided in register D8, the MW11-0 bits should be set to 00.

Figure 56. DMA/WAIT Control Register

SYSTEM CONTROL REGISTERS

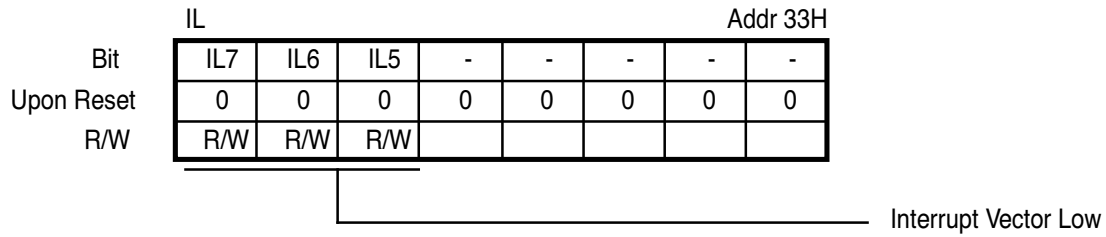

Figure 57. Interrupt Vector Low Register

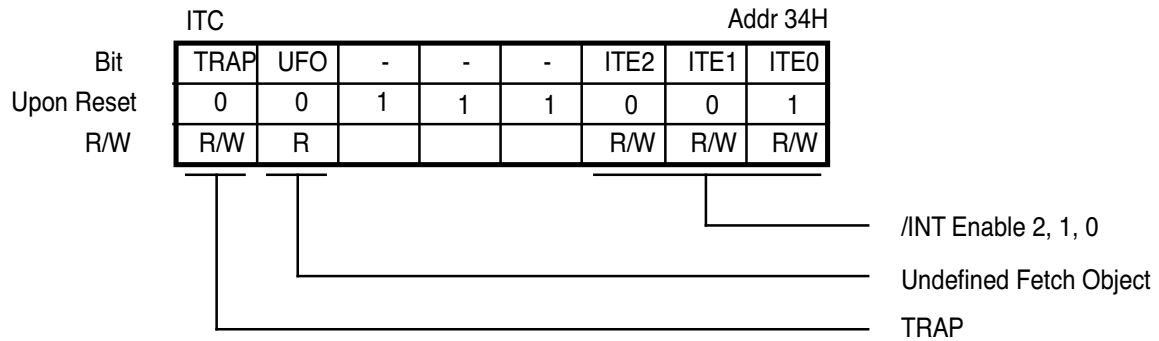
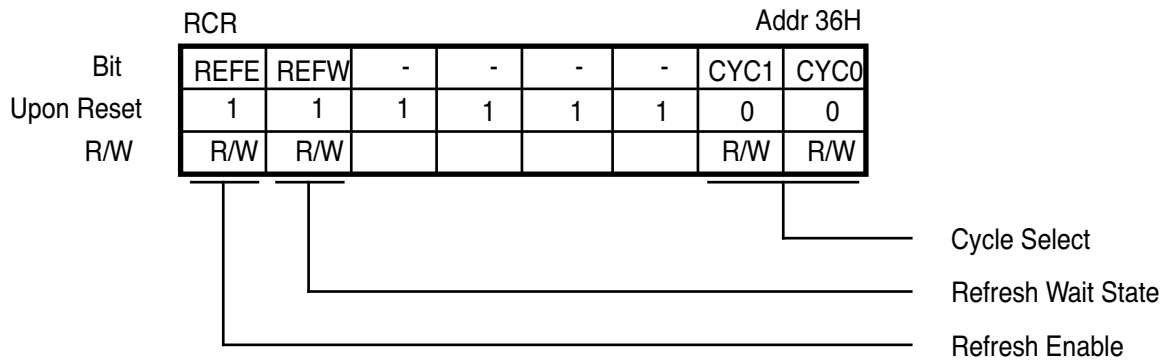

Figure 58. INT/TRAP Control Register



CYC1, 0	Interval of Refresh Cycle
00	10 states
01	20 states
10	40 states
11	80 states

Figure 59. Refresh Control Register

MMU REGISTERS

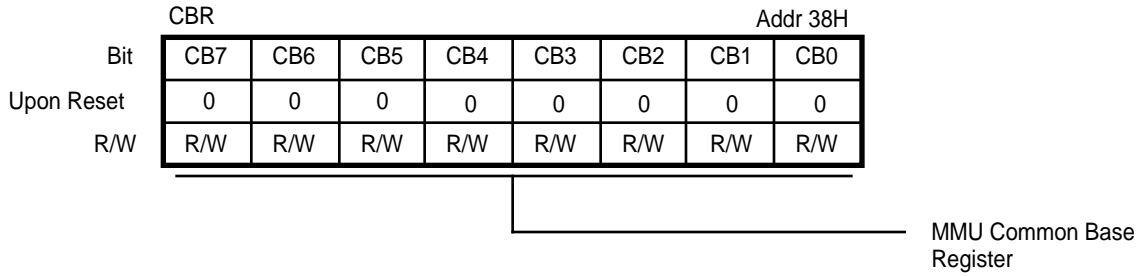

Figure 60. MMU Common Base Register

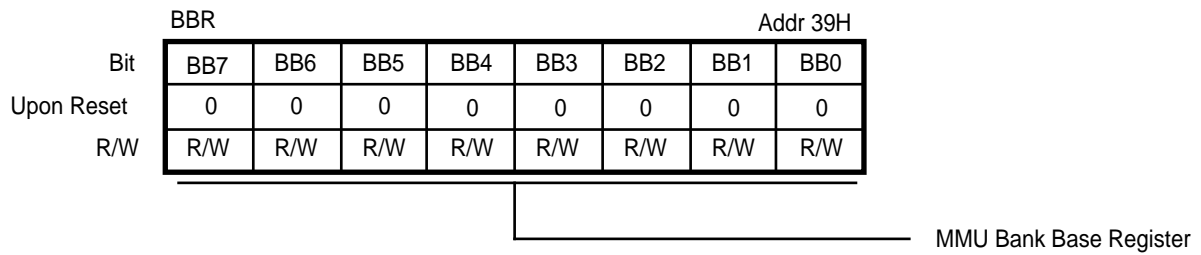

Figure 61. MMU Bank Base Register

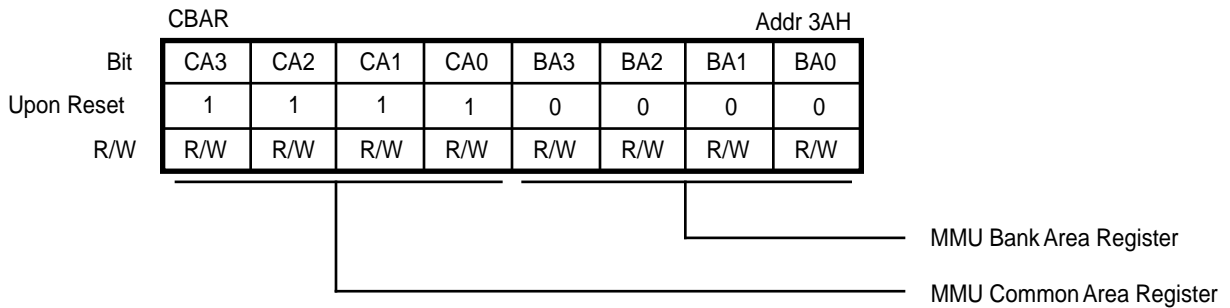
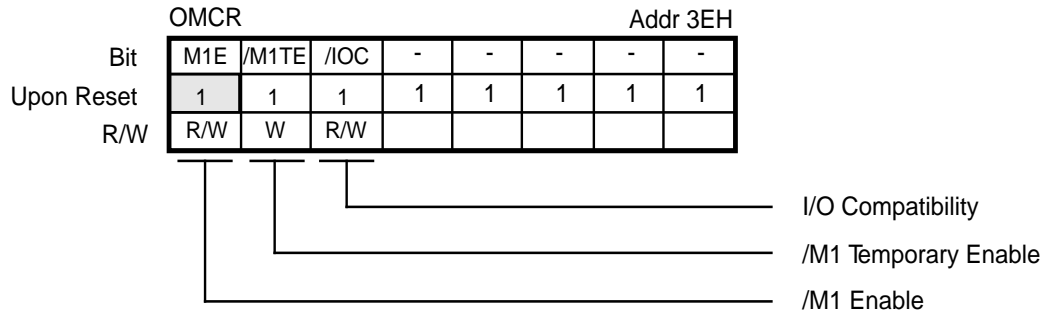

Figure 62. MMU Common/Bank Area Register

SYSTEM CONTROL REGISTERS



Notes:

1. This register should be programmed to 0x0xxxxxb (x = don't care) as a part of Initialization.
2. If the M1E bit is set to 1, the processor does not fetch a RETI instruction.

Figure 63. Operation Mode Control Register

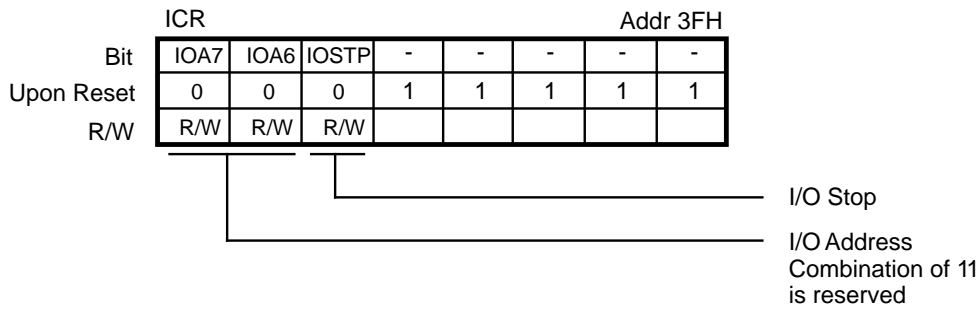

Figure 64. I/O Control Register

CPU CONTROL REGISTER

The CPU Control Register allows the programmer to select options that directly affect the CPU performance as well as controlling the STANDBY operating mode of the chip. The CPU Control Register (CCR) allows the programmer to change the divide-by-two internal clock to divide-by-one.

In addition, applications where EMI noise is a problem, the Z8S180 can reduce the output drivers on selected groups of pins to 33 percent of normal pad driver capability which minimizes the EMI noise generated by the part (Figure 65).

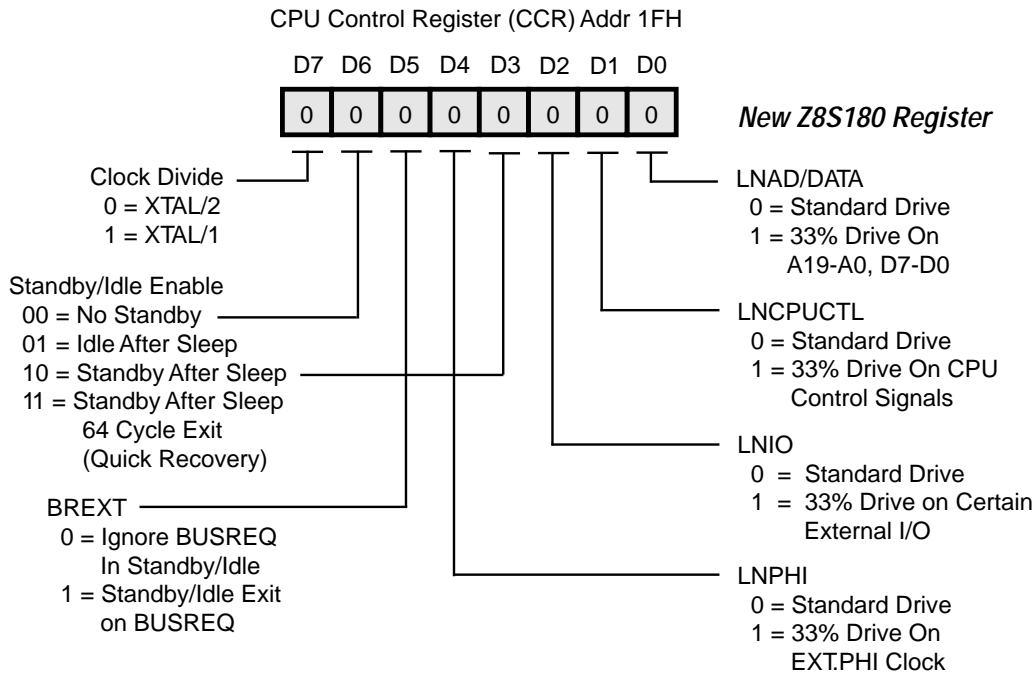

Figure 65. CPU Control Register

Bit 7. Clock Divide Select. Bit 7 of the CCR allows the programmer to set the internal clock to divide the external clock by two if the bit is 0 and divide-by-one if the bit is 1. Upon reset, this bit is set to 0 and the part is in divide-by-two mode. Since the on-board oscillator is not guaranteed to operate above 20 MHz, an external source must be used to achieve the maximum 33 MHz operation of the device, such as an external clock at 66 MHz with 50 percent duty cycle.

If an external oscillator is used in divide-by-one mode, the minimum pulse width requirement must be satisfied.

Bits 6 and 3. STANDBY/IDLE Enable. These two bits are used for enabling/disabling the IDLE and STANDBY mode.

Setting D6, D3 to 0 and 1, respectively, enables the IDLE mode. In the IDLE mode, the clock oscillator is kept oscillating but the clock to the rest of the internal circuit, including the CLKOUT, is stopped. The Z8S180 enters IDLE mode after fetching the second opcode of a SLEEP instruction, if the I/O STOP bit is set.

Setting D6, D3 to 1 and 0, respectively, enables the STANDBY mode. In the STANDBY mode, the clock oscillator is stopped completely. The Z8S180 enters STANDBY after fetching the second opcode of a SLEEP instruction, if the I/O STOP bit is set.

Setting D6, D3 to 1 and 1, respectively, enables the STANDBY-QUICK RECOVERY mode. In this mode, its operations are identical to STANDBY except that the clock recovery is reduced to 64 clock cycles after the exit conditions are gathered. Similarly, in STANDBY mode, the Z8S180 enters STANDBY after fetching the second opcode of a SLEEP instruction, if the I/O STOP bit is set.

Bit 5. BREXT. This bit controls the ability of the Z8S180 to honor a bus request during STANDBY mode. If this bit is set to 1 and the part is in STANDBY mode, a BUSREQ is honored after the clock stabilization timer is timed out.

Bit 4. LNPHI. This bit controls the drive capability on the PHI Clock output. If this bit is set to 1, the PHI Clock output is reduced to 33 percent of its drive capability.

Bit 2. LNIO. This bit controls the drive capability of certain external I/O pins on the Z8S180. When this bit is set to 1, the output drive capability of the following pins is reduced to 33 percent of the original drive capability:

/RTS0/TXS	TXA0
CKA1	TXA1
CKA0	TOUT

Bit 1. LNCPUCTL. This bit controls the drive capability of the CPU Control pins. When this bit is set to 1, the output drive capability of the following pins is reduced to 33 percent of the original drive capability:

/BUSACK	/IORQ
/RD	/RFSH
/WR	/HALT
/M1	ST
/MREQ	

Bit 0. LNAD/DATA. This bit controls the drive capability of the Address/Data bus output drivers. If this bit is set to 1, the output drive capability of the Address and Data bus output is reduced to 33 percent of its original drive capability.

ON-CHIP ENHANCED SERIAL COMMUNICATIONS CONTROLLER (EMSCC)

The Z80185 contains a single-channel EMSCC which features a 4-byte transmit FIFO and an 8-byte receive FIFO, this enhancement reduces the overhead required to provide data to, and get data from, the transmitter and receiver. The EMSCC also improves packet handling in SDLC mode to:

- automatically transmit a flag before the data;
- reset the Tx Underrun/EOM latch;
- force the TxD pin High at the appropriate time when using NRZI encoding;
- deassert the /RTS pin after the closing flag; and
- better handle ABORTed frames when using the 10x19 status FIFO.

The combination of these features, along with the data FIFOs, significantly simplifies SDLC driver software.

The CPU hardware interface has been simplified by relieving the databus setup time requirement and supporting the software generation of the interrupt acknowledge signal (/INTACK). These changes allow an interface with less external logic to many microprocessor families while maintaining compatibility with existing designs. I/O handling of the EMSCC is improved over the SCC, with faster response of the /DTR//REQ pin. The many enhancements added to the EMSCC permits a system design that increases overall system performance with better data handling and less interface logic.

Significant features of the EMSCC include:

- Hardware and software compatible with Zilog's SCC/ESCC
- 4-Byte Transmit FIFO
- 8-Byte Receive FIFO
- Programmable FIFO Interrupt Levels Provide Flexible Interrupt Response
- Improved SDLC Frame Status FIFO
- New Programmable Features Added with Write Register 7'

- Write registers: WR3, WR4, WR5, and WR10 are now readable
- Read Register 0 Latched During Access
- Many Improvements to Support SDLC/HDLC Transfers:
 - Deactivation of /RTS Pin after Closing Flag
 - Automatic Transmission of the Opening Flag
 - Automatic Reset of Tx Underrun/EOM Latch
 - Complete CRC Reception
 - TxD pin Automatically Forced High with NRZI Encoding when Using Mark Idle.
 - Receive FIFO Automatically Unlocked for Special Receive Interrupts when Using the SDLC Status FIFO.
 - Back-to-Back Frame Transmission Simplified
- Software Interrupt Acknowledge mode
- DPLL Counter Output Available as Jitter-Free Clock Source
- A Full-Duplex Channel with a Baud Rate Generator and Digital Phase-Locked Loop
- Multi-Protocol Operation Under Program Control
- Asynchronous or Synchronous mode

In addition, the following features have been added to the EMSCC channel in the Z80185:

- Programmable LocalTalk feature
- Non-Multiplexed /DTR Pin
- Internal Connection of DMA Request and /WAIT Signals
- EMSCC Programmable Clock
 - Programmed to be Equal to System Clock Divided by One or Two
 - Programmed by System Configuration Register

Note: The EMSCC programmable clock must be programmed to divide-by-two mode when operating above the following condition: PHI > 20 MHz at 5.0V

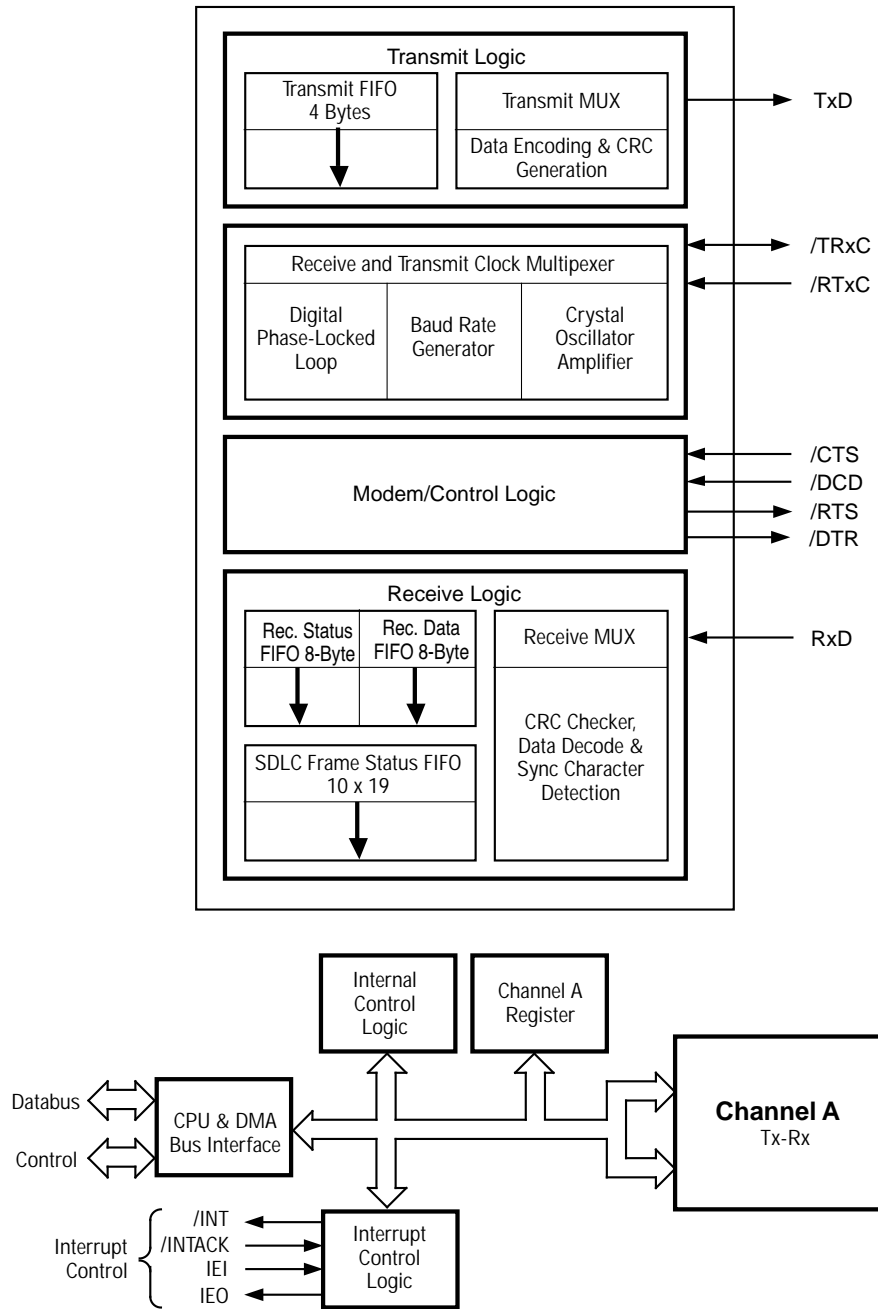

Figure 66. EMSCC Block Diagram

EMSCC

The Z80185 features a one-channel EMSCC that uses two I/O addresses:

EMSCC Channel A Control	I/O Address %E8
Data	I/O Address %E9

Divide-by-two should be programmed when operating the Z80185 beyond 20 MHz, 5V.

Note: Upon power-up, or reset, the system clock is equal to the EMSCC clock.

Initialization. The system program first issues a series of commands to initialize the basic mode of operation. This is followed by other commands to qualify conditions within the selected mode. For example, in the Asynchronous mode, character length, clock rate, number of stop bits, and even or odd parity should be set first. Then the interrupt mode is set, and finally, the receiver and transmitter are enabled.

Write Registers. The EMSCC contains 16 write registers (17 counting the transmit buffer) in each channel. These write registers are programmed separately to configure the functional "personality" of the channels. A new register, WR7', was added to the EMSCC and may be written to if WR15, D0 is set. Figure 50 shows the format of each write register.

Read Registers. The EMSCC contains ten read registers (11 counting the receive buffer) in each channel. Four of these may be read to obtain status information (RR0, RR1,

RR10, and RR15). Two registers (RR12 and RR13) are read to learn the baud rate generator time constant. RR2 contains either the unmodified interrupt vector (channel A) or the vector modified by status information (channel B). RR3 contains the Interrupt Pending (IP) bits (channel A only). RR6 and RR7 contain the information in the SDLC Frame Status FIFO, but is only read when WR15 D2 is set. If WR7' D6 is set, Write Registers WR3, WR4, WR5, WR7, and WR10 can be read as RR9, RR4, RR5, and RR14, respectively. Figure 51 shows the format of each read register.

With the Z80185, the EMSCC channel's DTR, Tx and Rx DMA Request and WAIT outputs are not subject to multiplexing and are routed separately to the CPU and pins.

In other words,

1. the DTR pin is not multiplexed and always follows WR5 bit 7;
2. if WR1 bits 7-6 are 10, and the processor reads the RDR when the RxFIFO is empty, or writes the TDR when the TxFIFO is full, the processor is "waited" until a character arrives or has been sent out;
3. WR1 bit 5 has no effect;
4. WR14 bit 2 should be kept 0;
5. WR1 bits 7-6 should not be programmed as 11.

A LocalTalk feature has been added in one EMSCC of the Z80185, operating as follows:

If a certain set of register bits are set, RTS acts as a LocalTalk Driver Enable output that operates as shown in Figure 50. All of the following bits and fields must be programmed exactly as shown to enable this mode:

- WR4.3-2 = 00: sync modes
- WR4.5-4 = 10: SDLC
- WR5.1 = 0: no RTS
- WR7.2 = 1: auto RTS deactivation
- WR10.3 = 1: mark idle
- WR5.4 = 1: Send Break

When the first five conditions above are set (as for LocalTalk operation), the WR5.4 bit is used as a Select LocalTalk Driver Enable control bit, rather than the Send Break command bit used in async mode.

Setting these register bits in this manner configures the EMSCC Transmitter to send three Flags before a frame, negating RTS during the first to create a coding violation, when software writes the first character of a frame to the TDR and TxFIFO. This mode also makes the Transmitter ensure at least 16 bits of idle time between a closing Flag and the end of frame interrupt. The RTS output is driven active for one bit time at the start of the first of the three Flags, then inactive for four bit times, then active again for the duration of the opening Flags, the frame, and closing Flag, plus 16 bit times thereafter.

There is one other difference in EMSCC operation when this new mode is enabled. The setting of the TxIP bit, that normally occurs after the last bit of the CRC is sent, is delayed until the 16-bit Idle is sent and RTS is negated.



Figure 67. EMSCC Transmitter Flag Commands

EMSCC REGISTERS

Write Register 0 (non-multiplexed bus mode)

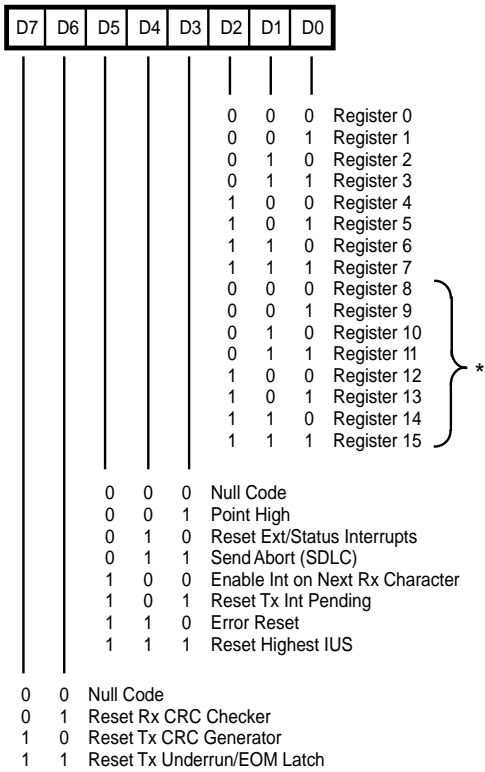

Write Register 2

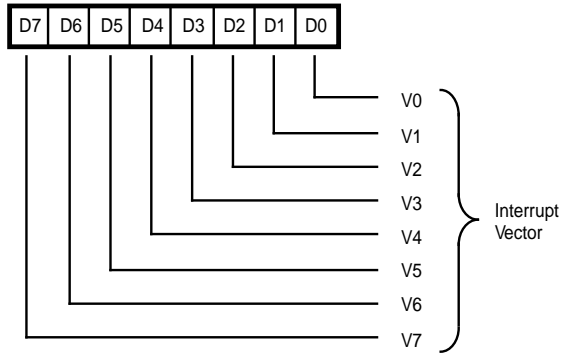

Write Register 3

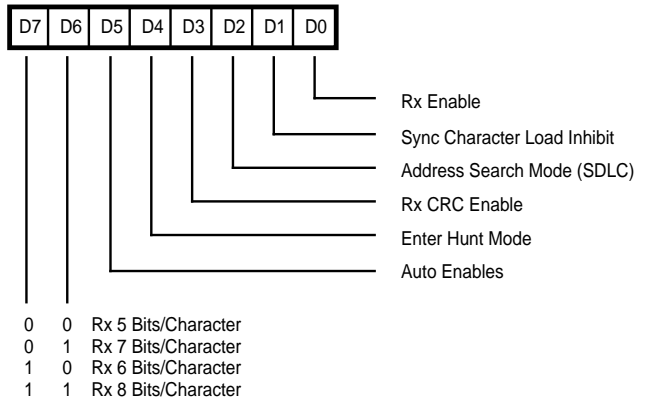

Write Register 1

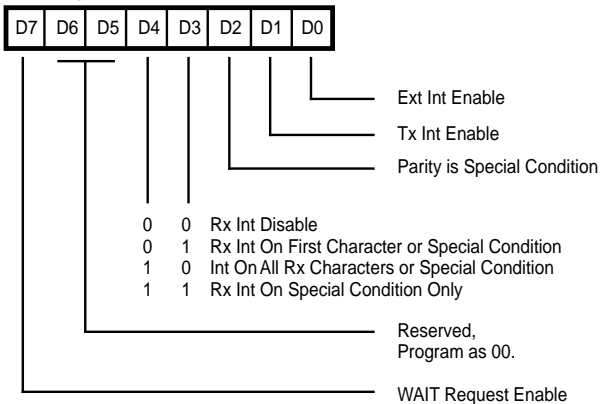

Write Register 4

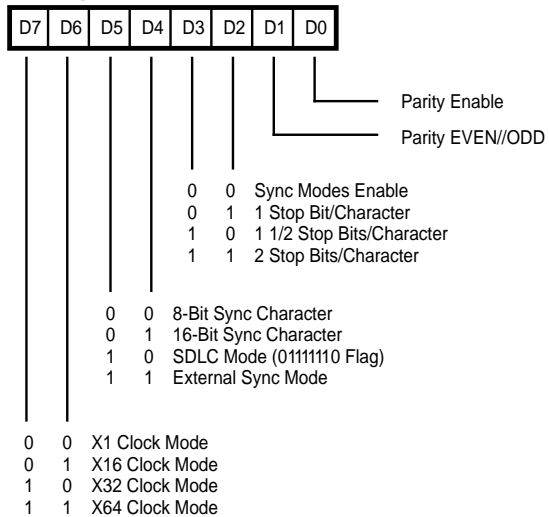

Figure 68. Write Register Bit Functions

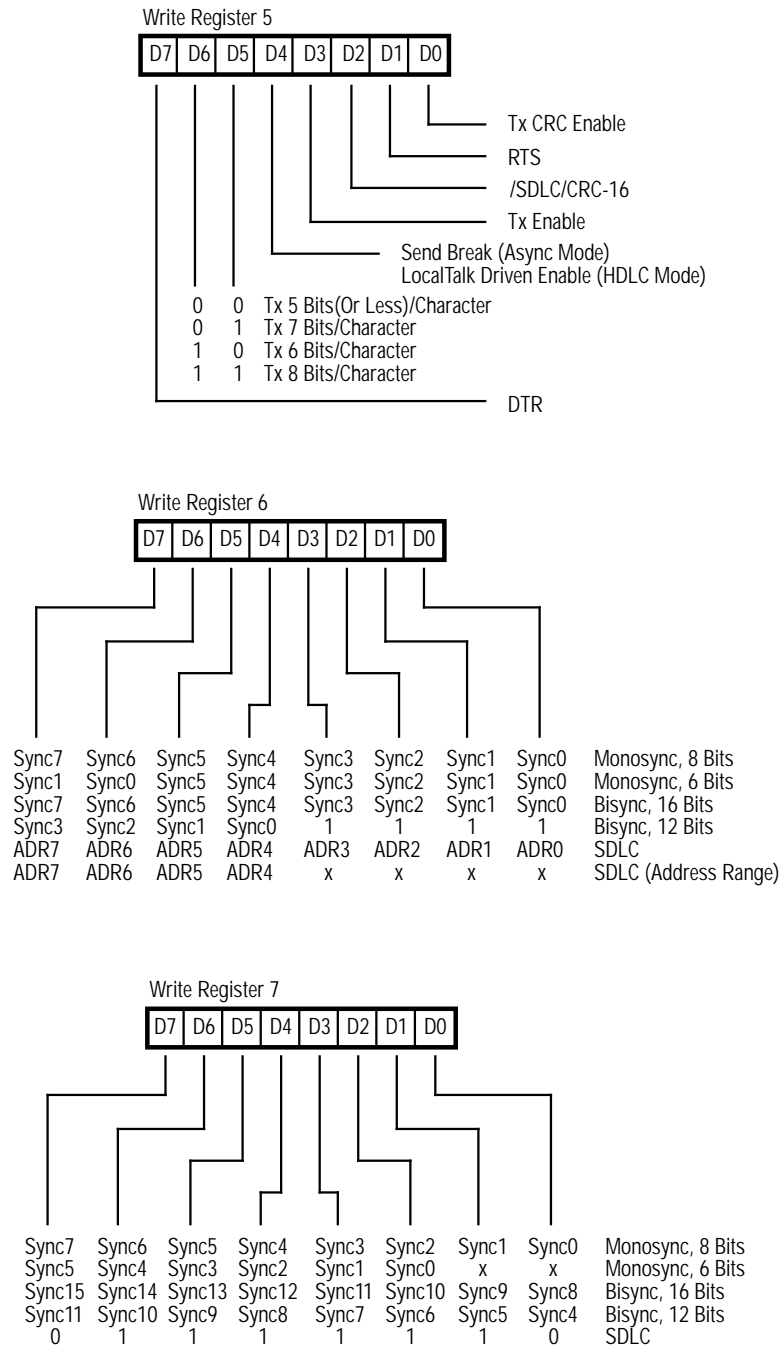
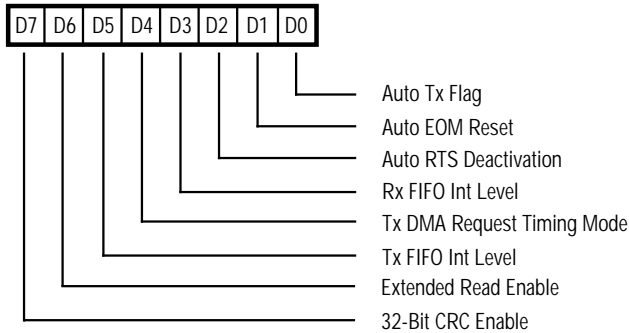

Figure 69. Write Register Bit Functions (Continued)

EMSCC REGISTERS (Continued)

WR' Prime



Write Register 10

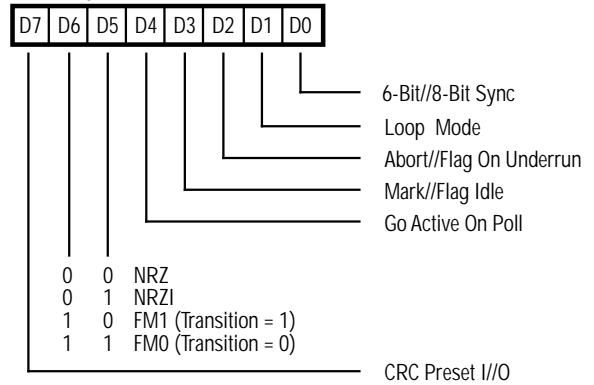

Write Register 9

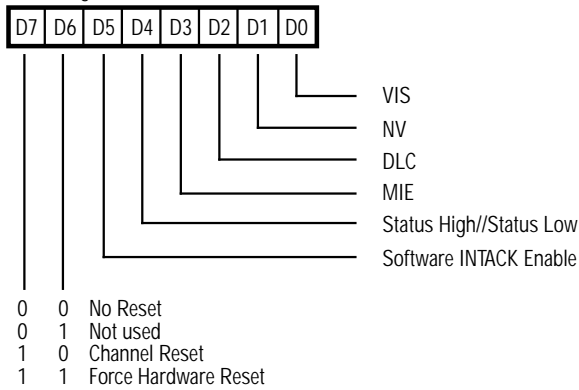

Write Register 11

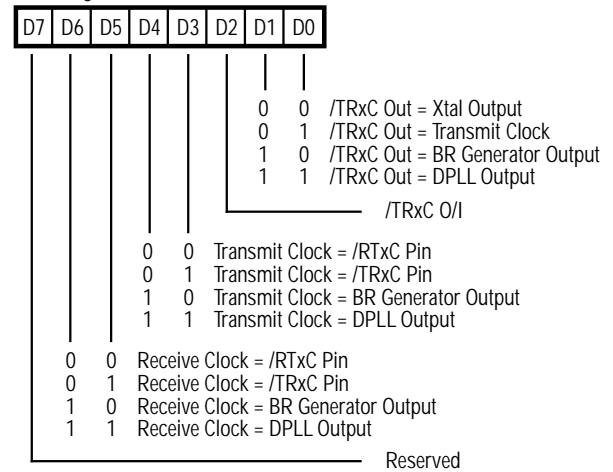

Figure 70. Write Register Bit Functions (Continued)

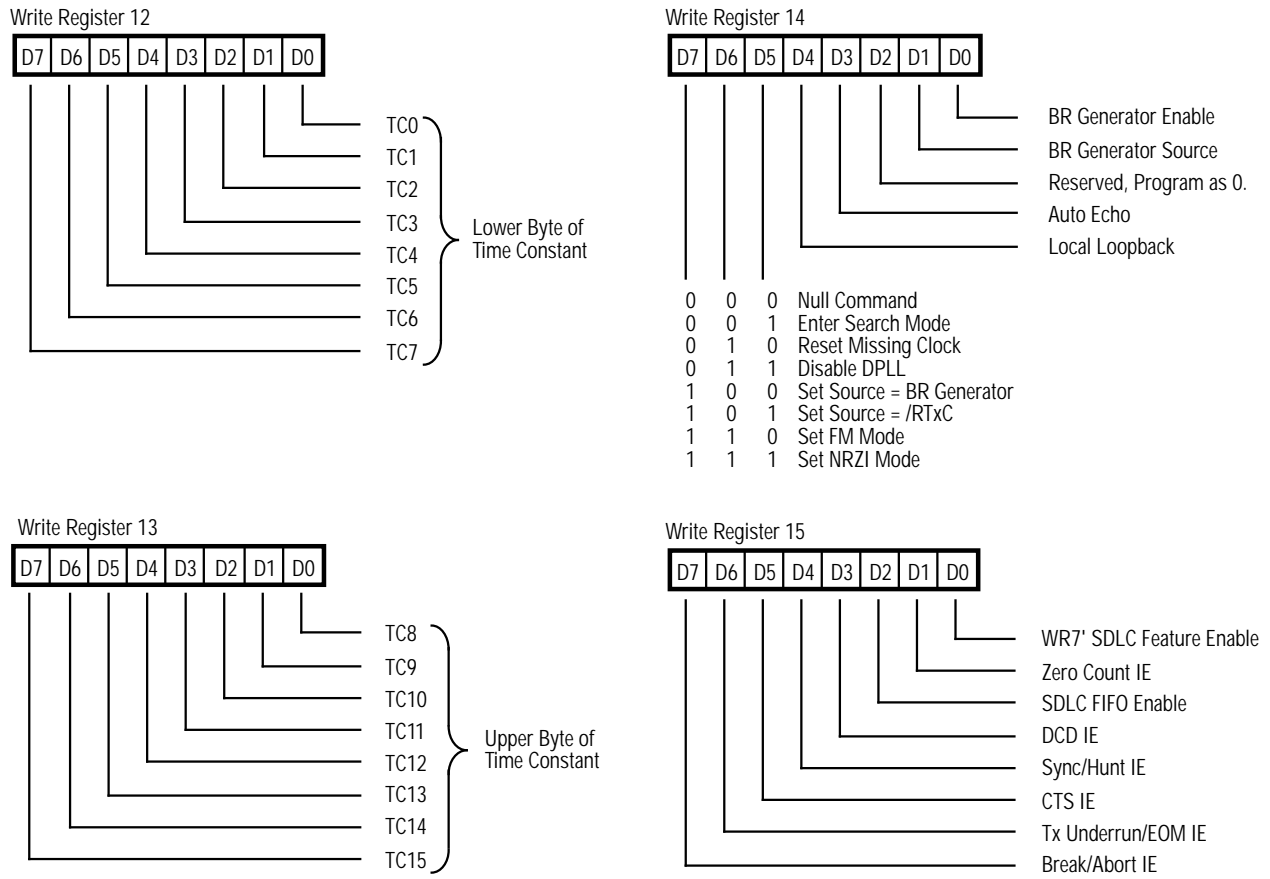
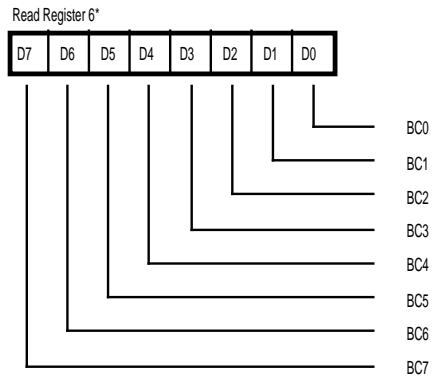
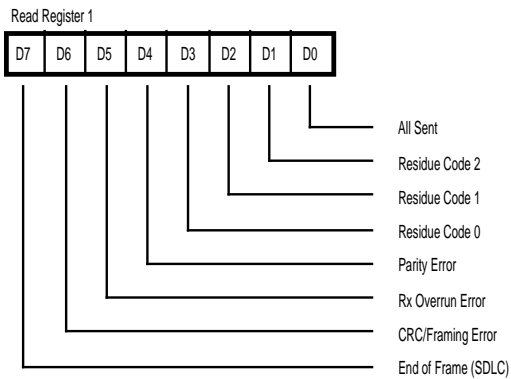
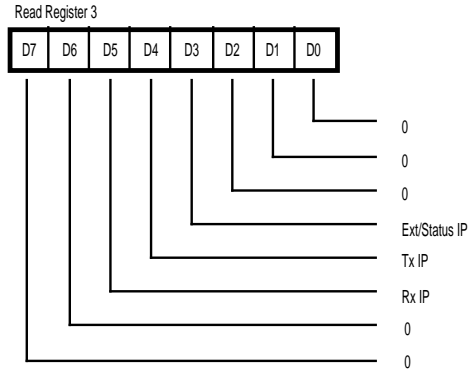
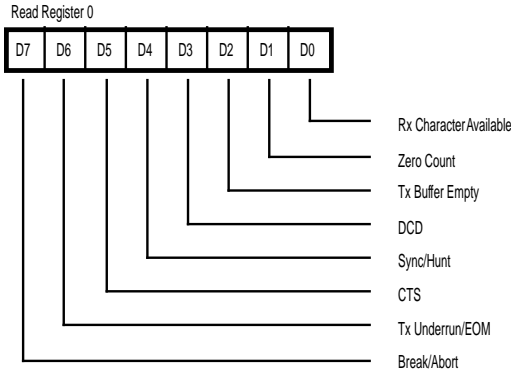

Figure 71. Write Register Bit Functions (Continued)

EMSCC REGISTERS (Continued)



*Can only be accessed if the SDLC FIFO enhancement is enabled (WR15 bit D2 set to 1)

SDLC FIFO Status and Byte Count (LSB)

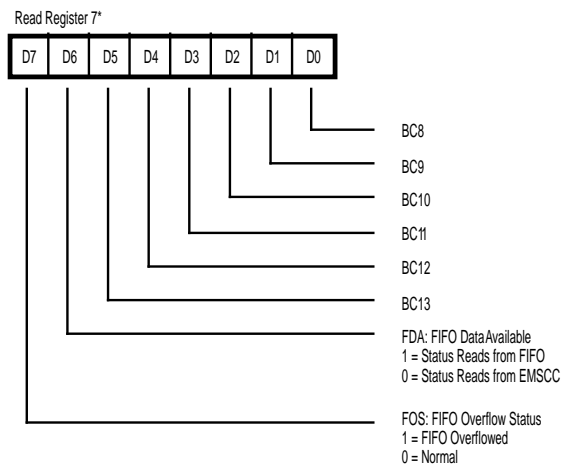
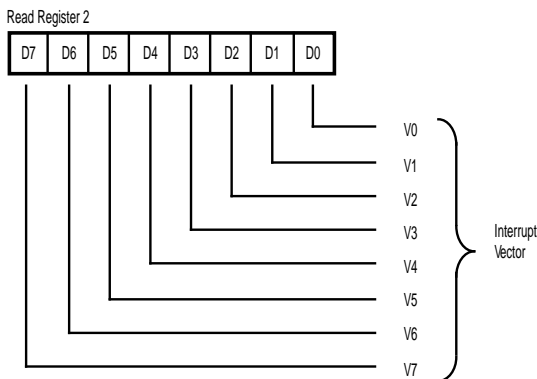

*Can only be accessed if the SDLC FIFO enhancement is enabled (WR15 bit D2 set to 1)

SDLC FIFO Status and Byte Count (LSB)

Figure 72. Read Register Bit Functions

Read Register 10

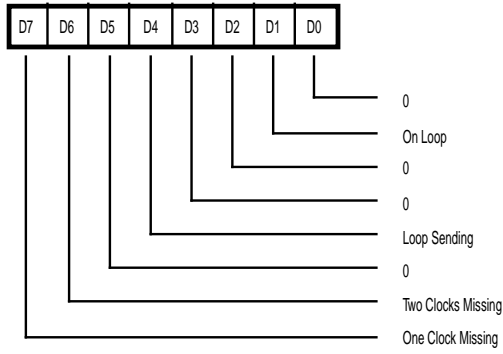

Read Register 13

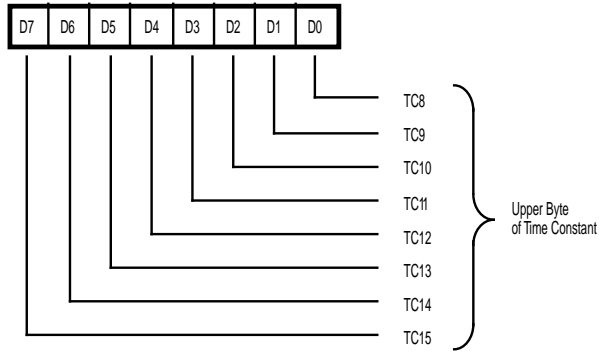

Read Register 12

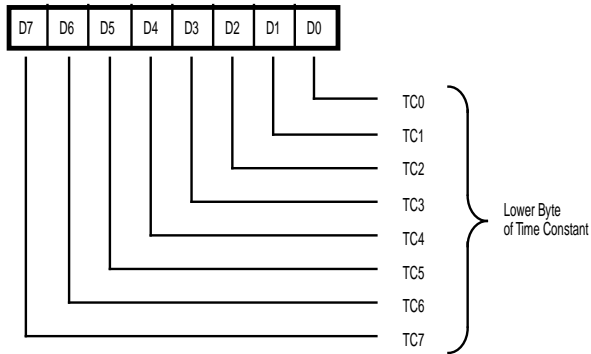

Read Register 15

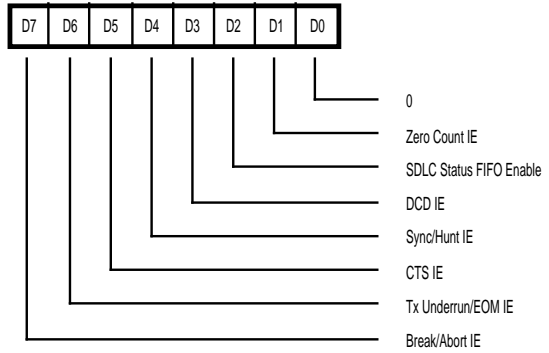

Figure 73. Read Register Bit Functions (Continued)

P1284 REGISTER MAP

Register Name	I/O Addr/Access
PARM Register	%D9 R/W
PARC Register	(asymmetric) %DA R/W
PARC2 Register	%DB WO
PART Register	%DC R/W
PARV Register	%DD R/W

Z80185 BIDIRECTIONAL CENTRONICS P1284 CONTROLLER

The Centronics P1284 Controller can operate in either the Host or Peripheral role in Compatibility mode (host to printer), Nibble or Byte mode (printer to host), and ECP mode (bidirectional). It provides no hardware support for the EPP mode, although it may be possible to implement this mode by software.

Nine control signals have dedicated hardware pins, and have ± 12 mA drive (P1284 Level 2) capability as does the 8-bit data port PIA27-20. **Note:** Signal names listed below are those for the original Compatible mode. The names shown in parentheses represent the same signal, but in a more recent mode. The Z80185 does not include hardware support for the P1284 EPP mode.

The following signals are outputs in a Peripheral mode, inputs in a Host mode:

- Busy (PtrBusy, PeriphAck)
- nAck (PtrClk, PeriphClk)
- PError (AckDataReq, nAckReverse)
- nFault (nDataAvail, nPeriphRequest)
- Select (Xflag)

The following signals are inputs in a Peripheral mode, outputs in a Host mode:

- nStrobe (HostClk)
- nAutoFd (HostBusy, HostAck)
- nSelectIn (P1284Active)
- nInit (nReverseRequest)

Note that, because the Host/Peripheral mode is fully controlled by software, a Z80185-based product can operate as a Host in one system, or as a Peripheral in another, without any change to the hardware. A Z80185-based product could even act as a Host at one time and a Peripheral at another time within the same system, if there is a mechanism to control such alternate use.

In general, the interface architecture automates operations that are seen as performance-critical, while leaving less frequent operations to software control. To achieve top performance, software should assign a DMA channel to the current direction of data flow.

Note: The IEEE 1284 Interface should be used with the /IOC bit (bit D5) in the OMCR set to 0. The setting of this bit primarily affects RLE expansion in peripheral ECP forward and host ECP reverse modes.

Bidirectional Centronics Registers

Reading the Parallel Controls (PARC) register allows software to sense the state of the input signals per the current mode, plus two or three status flags:

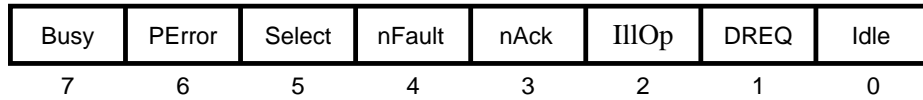

Figure 74a. Reading PARC in a Host Mode
(I/O Address %DA)

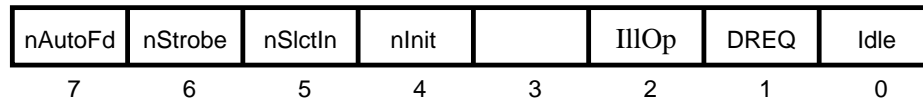

Figure 74b. Reading PARC in a Peripheral Mode
(I/O Address %DA)

The controller sets IIIOp (Illegal Operation) when it detects an error in the protocol, for example, if it's in Peripheral mode and it detects that the host has driven P1284Active (nSelectIn) Low at a time that mandates an immediate Abort, that is, outside one of the "windows" in which this event indicates an organized disengagement. If "status interrupts" are enabled, such an interrupt is always requested when IIIOp is set. Writing PARM with NewMode=1 clears IIIOp.

DREQ is the Request presented to the DMA channels, which may or may not be programmed to service this request. If not, an interrupt can be enabled when DREQ is set.

Writing to PARC allows the software to set and clear the output signals per the current mode:

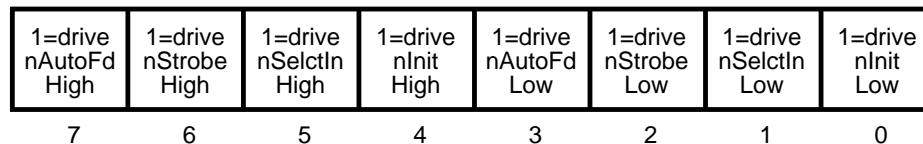

Figure 75a. Writing to PARC in a Host Mode
(I/O Address %DA)

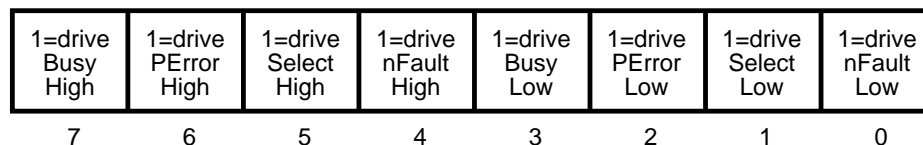

Figure 75b. Writing to PARC in a Peripheral Mode
(I/O Address %DA)

Z80185 BIDIRECTIONAL CENTRONICS P1284 CONTROLLER (Continued)

Because there are five outputs in a Peripheral mode, another register, called PARC2, allows software to change the nAck line, rather than the Select line:

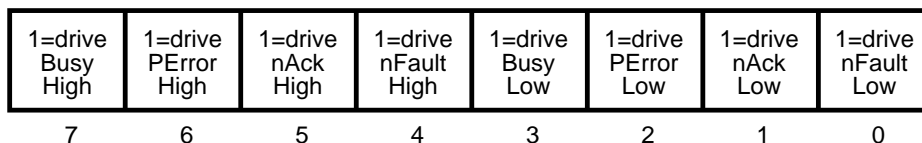

Figure 76. Writing to PARC2 in a Peripheral Mode
(I/O Address %DB)

The Parallel mode register (PARM) includes the basic mode control of the controller:

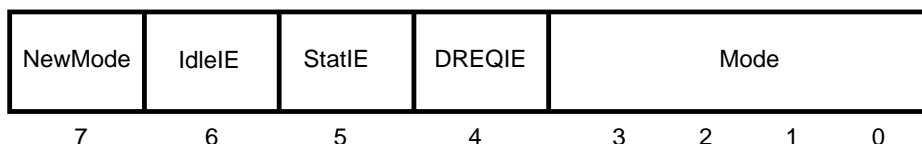

Figure 77. PARM (I/O Address %D9)

NewMode = 1 reinitializes the state machine to the initial state for the mode called out by MODE. Never change MODE without writing a 1 in this bit.

IdleIE = 1 enables interrupts when the controller sets the Idle flag. When software uses a DMA channel to provide data to the P1284 controller, it can be expected that the channel will do so in a timely manner, and thus, that an Idle condition signifies that the channel has finished transferring the block. (Software can also enable an interrupt from the DMA channel, but on the transmit side, such interrupts are not well-synchronized to events on the P1284 controller.) Conversely, if software provides data, Idle may not be grounds for an interrupt.

Some modes set the Idle flag when they are entered. However, such a setting of Idle never requests an interrupt.

StatIE = 1 enables "status" interrupts that are described separately for each mode.

DREQIE = 1 enables interrupts when the controller sets DREQ, except that in those modes that set DREQ when they are entered, such setting doesn't request an interrupt.

Table 3. Bidirectional Centronics Mode Selection

MODE	
0000	Non-P1284 mode
0001	Peripheral Compatible/Negotiation mode
0010	Peripheral Nibble mode
0011	Peripheral Byte mode
0100	Peripheral ECP Reverse mode
0101	Peripheral Inactive mode
0110	Peripheral ECP Forward mode with software RLE handling
0111	Peripheral ECP Forward mode with hardware RLE expansion
1000	Host Negotiation mode
1001	Host Compatible mode
1010	Host Nibble mode
1011	Host Byte mode
1100	Host ECP Forward mode
1101	Host Reserved mode
1110	Host ECP Reverse mode with software RLE handling
1111	Host ECP Reverse mode with hardware RLE expansion

A second output register has been added for PIA27-20. Writing to either the Z80181-compatible PIA 2 Data Register (address E3) or the new Alternate PIA 2 Data Register (address EE) writes to the Output Holding Register (OHR). When the PIA27-20 pins are outputs, the outputs of the OHR are the inputs to the second register, which is called the I/O register (IOR), these outputs drive the PIA27-20 pins. When the pins are inputs, they are the inputs to the IOR, which can be read from the PIA 2 Data Register (address E3).

In non-P1284 mode, Host Negotiation mode, Reserved Modes, and in Peripheral Compatible/Negotiation mode when the host drives nSelectIn (P1284Active) High to

select negotiation, the direction of the PIA27-20 pins are controlled by the PIA 2 Data Direction register, as on the Z80181. Also in these modes the IOR is loaded on every PHI clock, so that operation is virtually identical to the Z80181. In other modes the controller controls the direction of PIA27-20 and when the IOR is loaded.

A Time Constant Register PART must be loaded by software with the smallest number of PHI clocks that equals or exceeds the "critical time" for the mode selected in PARM. The critical time is 750 ns for Host Compatible mode, 500 ns for most other modes, and the time necessary to indicate DMA completion in Host ECP Forward and Peripheral ECP Reverse modes.

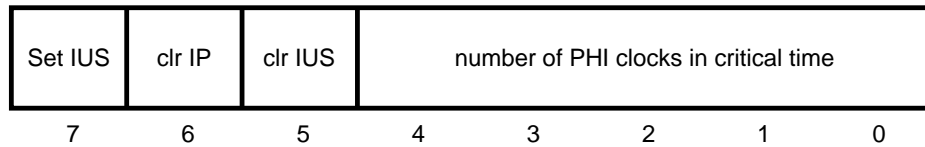

Figure 78. PART Write (I/O Address %DC)

Reading PART yields the status of the IP and IUS bits, which are described in the Bidirectional Centronics Interface section:

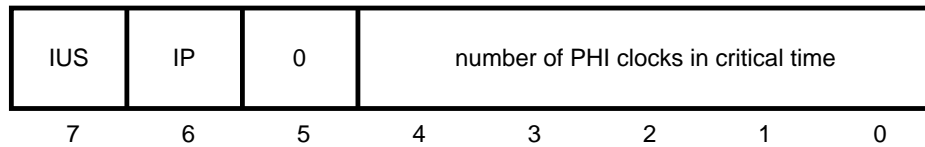

Figure 79. PART Read (I/O Address %DC)

The Vector Register PARV must be loaded by software with the interrupt vector to be used for interrupts from this controller.

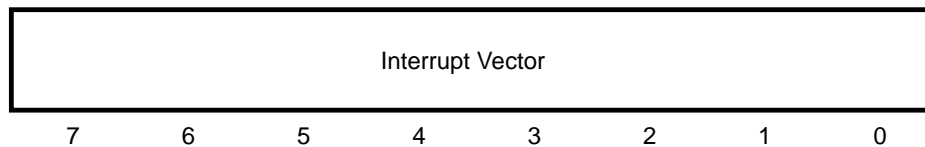

Figure 80. PARV (I/O Address %DD)

Z80185 BIDIRECTIONAL CENTRONICS P1284 CONTROLLER (Continued)

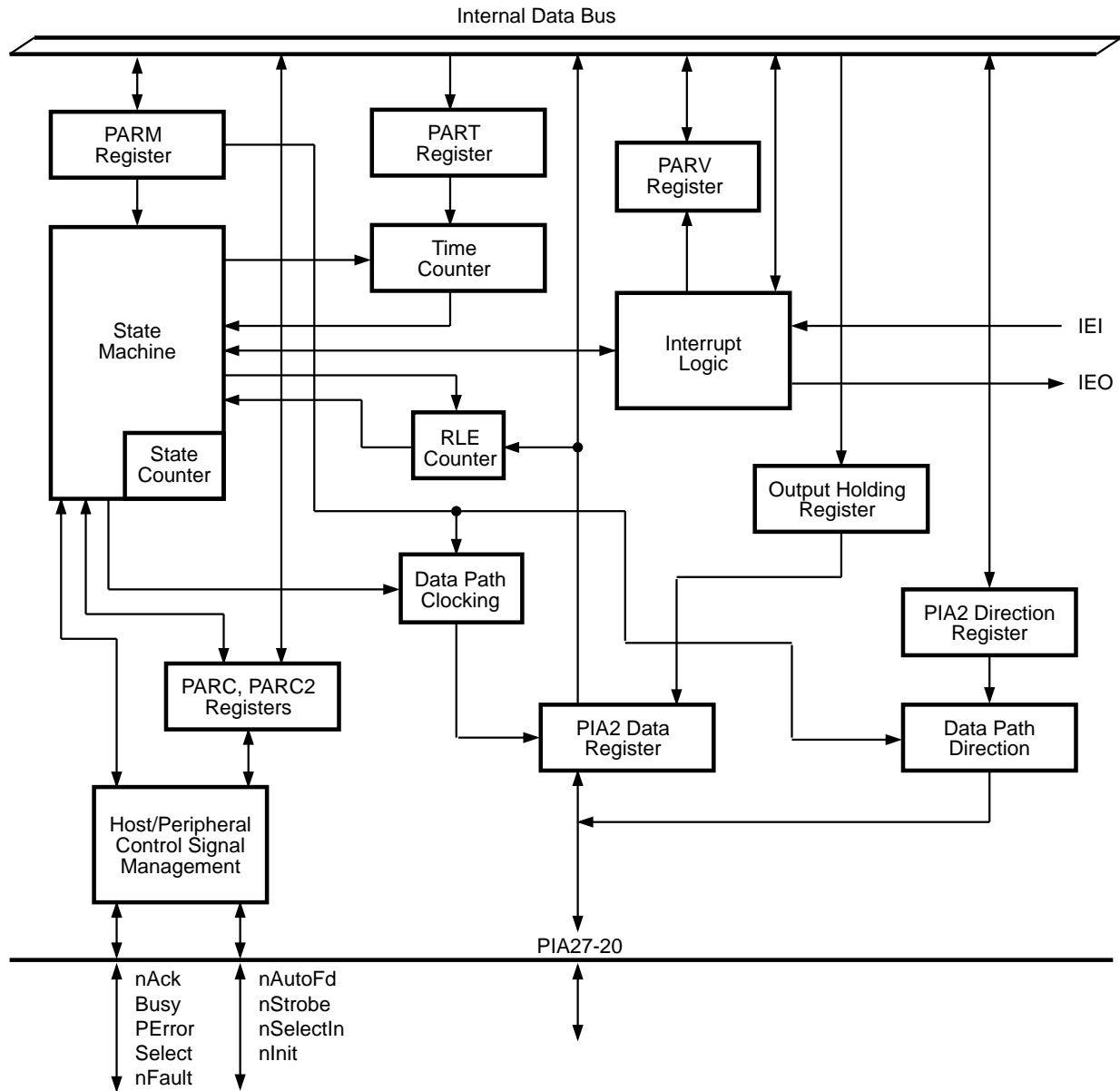

Figure 81. Bidirectional Centronics P1284 Controller
Functional Block Description

Interrupts

As in other Zilog peripherals, the controller includes an interrupt pending bit (IP), and an interrupt under service bit (IUS). The controller is part of an on-chip interrupt acknowledge daisy-chain that extends from the IEI pin, through the EMSCC, CTC, and this controller in a programmable priority order, and from the lowest-priority of these devices to the IEO pin. The interrupt request from the controller is logically ORed with /INT0 and other on-chip interrupt requests to the processor.

The controller sets its IP bit whenever any of three conditions occurs:

1. PARM4 is 1, and the controller sets the DREQ bit. This does not include when the controller forces the DREQ bit to 1, when software first places the controller in Peripheral Nibble, Peripheral Byte, Peripheral ECP Reverse, Host Compatible, or Host ECP Forward mode.
2. PARM5 is 1, and a mode-dependent “status interrupt” condition occurs. The following sections describe the status interrupt conditions (if any) for each mode.
3. PARM6 is 1, and the controller sets the Idle bit, except when the controller forces the Idle bit to 1, when software first places the controller in Peripheral Nibble, Peripheral Byte, Peripheral ECP Reverse, Host Compatible, or Host ECP Forward mode. The following sections describe when Idle is set in each mode.

Once IP is set, it remains set until software writes a 1 to PART6.

The controller will begin requesting an interrupt of the processor whenever IP is set, its IEI signal from the on-chip daisy-chain is High/true, and its IUS bit is 0. Once it starts requesting an interrupt, the controller will continue to do so until /IORQ goes Low in an interrupt-acknowledge cycle, or IP is 0, or IUS is 1.

The controller drives its IEO output High, if its IEI input is High, and its IP and IUS bits are both 0. A Z80 interrupt acknowledge cycle is signalled by /M1 going Low, followed by /IORQ going Low. The controller, and all other devices in the daisy-chain, freeze the contribution of their IP bits to their IEO outputs while /M1 is Low, which prevents new events from affecting the daisy-chain. By the time /IORQ goes Low, one and only one device will have its IEI pin High and its IEO pin Low — this device responds to the interrupt by providing an interrupt vector, and setting its IUS bit. This controller also clears its IP bit when it responds to an interrupt acknowledge cycle.

The interrupt service routine, that is initiated when the interrupt vector value identifies an interrupt from this controller, should save the processor context and then proceed as follows:

1. If the ISR does not allow nested interrupts, it can clear the IP and IUS bits by writing hex 60, plus the “critical time” value to the PART, then read the status from PARC and proceed based on that status. Near the end of the ISR it should re-enable processor interrupts.
2. If the ISR allows nested interrupts, it can re-enable processor interrupts, clear IP by writing hex 40 plus the “critical time” value to the PART, and then read the status from PARC and proceed based on that status. At the end of the ISR it should clear IUS to allow further interrupts from this controller and devices lower on the daisy-chain, by writing hex 20 plus the “critical time” value to the PART.

The remainder of this section describes the operation of the various PARM register modes that can be selected.

Non-P1284 Mode

The Z80185 defaults to this mode after a Reset, and this mode is compatible with the use of PIA27-20 on the Z80181. The directions of PIA27-20 can be controlled individually by writing to register E2, as on the Z80181. The state of outputs among PIA27-20 can be set by writing to register E3, and the state of all eight pins can be sensed by reading register E3. The Busy, nAck, PError, nFault, and Select pins are tri-stated in this mode, while nStrobe, nAutoFd, nSelectIn, and nInit are inputs. There are no status interrupts in this mode.

Peripheral Inactive Mode

This mode operates identically to Non-P1284 mode as described above, except that the Busy, nAck, PError, nFault, and Select pins are outputs that can be controlled via the PARC and PARC2 registers, and status interrupts can occur in response to any edge on nAutoFd, nStrobe, nSelectIn, or nInit. This mode differs from Peripheral Compatibility/Negotiation mode with nSelectIn (P1284 Active) High, only in that the controller will not operate in Compatibility mode if nSelectIn goes Low.

Z80185 BIDIRECTIONAL CENTRONICS P1284 CONTROLLER (Continued)**Host Compatible Mode**

1. Setting this mode configures PIA27-20 as outputs regardless of the contents of register E2. When entering this mode, the controller sets the Idle and DREQ bits, but these settings do not request an interrupt.
2. If software, or a DMA channel, writes eight bits to the Output Holding Register (OHR) when Idle is set, the controller transfers the byte to the Input/Output Register and negates DREQ only momentarily, so as to request another byte from software or the DMA channel.
3. In this mode, the nAutoFd line is not under control of the PARC register, but rather under control of which register the software uses to write data to the OHR. Each time the controller transfers a byte from the OHR to the Input/Output Register, it sets nAutoFd High if the byte was written to address E3, and Low if the byte was written to the "alternate" address EE. In a DMA application all of the bytes transferred from one output buffer will have the same state of nAutoFd, but this state can be changed from one buffer to the next by changing the I/O address used by the DMA channel. In non-DMA applications software can set the state of nAutoFd for each character, by writing data to the two different register addresses.
4. When a data byte has been valid on PIA27-20 for 750 ns (as controlled by the PART register), and the Busy and PError lines are Low and the Select, nAck, and nFault lines are High, the controller drives nStrobe Low. After the controller has held nStrobe Low for 750 ns it drives nStrobe back to High. Then it waits for 750 ns of data hold time to elapse. If software or a DMA channel has written another byte to the Output Holding Register (thus clearing DREQ) by the time this wait is satisfied, the controller transfers the byte from the Output Holding Register to the Input/Output Register, sets DREQ again, and returns to the event sequence at the start of this paragraph. Otherwise, it sets Idle and returns to the event sequence at the start of paragraph #2.

Status interrupts in this mode include rising and falling edges on PError, nFault, and Select.

Host Negotiation Mode

Setting this mode puts PIA27-20 under control of registers E2 and E3, as on the Z80181.

Software has complete control of the controller, and can either revert to Host Compatibility mode, or set one of the following Host modes, depending on how the peripheral responds to the Negotiation value(s).

Status interrupts in this mode include rising and falling edges on PtrClk (nAck), nAckReverse (PError), and nPeriphRequest (nFault). nFault is not used during actual P1284 negotiation, but is included because these events are significant during Byte and ECP mode idle times.

Host Reserved Mode

This mode differs from Host Negotiation mode only in that there are no status interrupts in this mode.

Peripheral Compatible/Negotiation Mode

In this mode, if P1284Active (nSelectIn) is Low, the controller sets PIA27-20 as inputs, regardless of the contents of register E2; when P1284Active (nSelectIn) is High, PIA27-20 are under the control of registers E2 and E3. On entry to this mode, the controller sets the Idle bit, if DREQ is set from a previous mode.

If, in this mode, nStrobe goes (is) Low, P1284Active (nSelectIn) is Low, and DREQ is 0, indicating that any previous data has been taken by the processor or DMA channel, the controller captures the data on PIA27-20 into the Input/Output Register, sets DREQ to notify software or the DMA channel to take the byte, drives the Busy line High, and one PHI clock later drives nAck Low. When at least 500 ns (as controlled by the PART register) have elapsed, the controller drives nAck back to High. One PHI clock later, if the CPU or DMA has taken the data and thus cleared DREQ, the controller drives Busy back to Low, otherwise it sets Idle.

Select, PError and nFault are under software control in this mode, and nAutoFd can be sensed by software, but has no other effect on operation.

In this mode, software should monitor for the condition P1284Active (nSelectIn) High, and nAutoFd Low simultaneously. If software detects this state, it should participate in a Negotiation process. Software should read the value on PIA27-20 and set PError, nFault, XFlag, and nAck as appropriate for the data value. As long as P1284Active (nSelectIn) remains High in this mode, software is in complete control of the controller. After the host has driven nStrobe Low and then High again for an acceptable value, software should reprogram the MODE field to the appropriate one of the following Peripheral modes.

Status interrupts in this mode include rising and falling edges on P1284Active (nSelectIn) and nInIt, and rising and falling edges on HostBusy (nAutoFd) and HostClk (nStrobe) while P1284Active (nSelectIn) is High.

Host Nibble Mode

1. If, during Host Negotiation mode, software has placed the value 00 or 04 on the data lines, and received a positive response on Xflag (Select) and a Low on nDataAvail (nFault) at a rising edge of PtrClk (nAck), then after optionally programming a DMA channel to store data, it should set this mode.
2. For each byte in this mode, the controller drives HostBusy (nAutoFd) Low and waits until DREQ is cleared, indicating that the CPU or DMA has taken any previous data, and the peripheral has driven PtrClk (nAck) Low. At this point it samples the other four status lines from the peripheral into the less-significant four bits of the Input/Output Register as follows:

Table 4. Nibble Mode Bit Assignments

Signal	First Data Bit	Second Data Bit
Busy	3	7
PError	2	6
Select	1	5
nFault	0	4

The controller then drives HostBusy (nAutoFd) back to High, and waits for the peripheral to drive PtrClk (nAck) back to High. Then it drives HostBusy (nAutoFd) back to Low and waits for the peripheral to drive PtrClk (nAck) Low. At this point it samples the four status lines from the peripheral into the most-significant four bits of the Input/Output Register, as shown above. Then it drives HostBusy (nAutoFd) back to High, sets the DREQ bit, and waits for the peripheral to drive PtrClk (nAck) back to High. When this occurs, if the peripheral is driving nDataAvail (nFault) Low, indicating more data is available, the controller then returns to the event sequence at the start of paragraph #2.

3. If nDataAvail (nFault) is High at a rising edge of nAck in this mode, indicating that the peripheral has no more data, the controller sets Idle and waits for software to program it back to Host Negotiation mode. Software can then select the next mode (reference IEEE P1284 specification).

If host software is programmed not to select all the data that a peripheral has available, it should first disable the DMA channel, if one is in use, then wait for DREQ to be 1 and PtrClk (nAck) to be High. If nDataAvail (nFault) is Low at this point, the controller will have already driven HostBusy (nAutoFd) Low to solicit the next byte. Software should then program the controller back to Host Negotiation mode, read the IOR to get the current byte, and take the next byte from the peripheral under software control. After the peripheral drives nAck High after the second nibble, software can drive P1284Active (nSelectIn) Low to tell the peripheral to leave Nibble mode.

There are no status interrupts in Host Nibble mode.

Z80185 BIDIRECTIONAL CENTRONICS P1284 CONTROLLER (Continued)**Peripheral Nibble Mode**

1. Software shouldn't set this mode until there is reverse data available to send. In other words, it should implement the P1284 "reverse idle mode" via software in Peripheral Compatibility/Negotiation mode. After software has driven nDataAvail (nFault), AckDataReq (PError), and Xflag (Select) all Low to signify that data is available, then driven PtrClk (nAck) High after 500 ns, and if requested programmed a DMA channel to provide data to send, when it sees HostBusy (nAutoFd) Low to request data, software should set this mode.

Setting this mode sets DREQ and Idle, but these settings do not request an interrupt. The PIA27-20 pins remain configured for data input but are not used. Instead, four of the five control outputs are driven with the LS and MS four bits of the Input/Output Register, as shown in Table 2, while PtrClk (nAck) serves as a handshake/clock output. On entering this mode the hardware begins routing bits 3-0 of the IOR to these lines.

2. If software, or a DMA channel, writes a byte to the Output Holding Register when Idle is set, the controller immediately transfers the byte to the IOR and clears Idle, and negates DREQ only momentarily to request another byte from software or the DMA channel.
3. After data has been valid on the four control outputs for 500 ns (as controlled by the PART register), the controller drives the PtrClk (nAck) line Low. Then it waits for the host to drive the HostBusy (nAutoFd) line back to High, after which it drives PtrClk (nAck) back to High, switches the four control lines to bits 7-4 of the IOR, and begins waiting for the host to drive HostBusy (nAutoFd) back to Low. When bits 7-4 have been valid for 500 ns and the host has driven HostBusy (nAutoFd) Low, the controller drives PtrClk (nAck) Low again and begins waiting for the host to drive HostBusy (nAutoFd) High. When HostBusy (nAutoFd) has been driven High, the controller returns the four control outputs to the state set by software in PARC. At this point, if software or a DMA channel has not yet written another byte to the Output Holding Register (thus clearing DREQ), the controller sets Idle and waits for software to do so. If/when software or a DMA channel has written a new byte to the OHR, the controller transfers the byte to the IOR, sets DREQ, and clears Idle if it had been set. Then, when the control outputs have been valid for 500 ns, the controller drives PtrClk (nAck) to High. It then waits for the host to drive HostBusy (nAutoFd) back to Low, at which time it switches the four control lines back to bits 3-0 of the IOR and returns to the event sequence at the start of this paragraph.

If there is no more data to send, when the controller sets Idle, software should modify PARC to make nDataAvail (nFault) and AckDataReq (PError) High, and then change the mode to Peripheral Compatible/Negotiation. Then (after 500 ns) software should set PtrClk (nAck) back to High in PARC and enter Reverse Idle state.

Status interrupts in Peripheral Nibble mode include rising and falling edges on P1284Active (nSelectIn) and nInit. The controller sets the **IIOp** (Illegal Operation) bit if P1284Active (nSelectIn) goes Low in this mode, before it drives nAck High for the status states on the four control lines, or after the host drives HostBusy Low thereafter, in which case software should immediately enter Peripheral Compatibility/Negotiation mode. If P1284Active goes Low, but **IIOp** stays 0, indicating that the Host negated P1284Active in a legitimate manner, software should enter Peripheral Inactive mode for the duration of the "return to Compatibility mode", and then enter Peripheral Compatibility/Negotiation mode.

Host Byte Mode

1. When in Host Negotiation mode the software has presented the value hex 01 or 05 on PIA27-20, it has been acknowledged by the peripheral, and the peripheral has driven nDataAvail (nFault) and AckDataReq (PError) to Low to indicate data availability and then driven PtrClk (nAck) back to High, software should set this mode. This sets PIA27-20 as inputs regardless of the contents of register E2, and clears the Idle flag. The controller then waits 500 ns (as controlled by the PART register) before proceeding.
2. For each byte, the controller drives HostBusy (nAutoFd) Low to indicate readiness for a byte from the peripheral. Then it waits for PtrClk (nAck) to go Low, at which time it captures the state of PIA27-20 into the Input/Output Register; sets the DREQ bit to request software, or the DMA channel to take the byte, and drives HostBusy (nAutoFd) High and HostClk (nStrobe) Low. When software, or the DMA channel, has taken the byte (thus clearing DREQ) and the peripheral has driven PtrClk (nAck) back High, and at least 500 ns after driving HostClk (nStrobe) Low, the controller drives HostClk (nStrobe) back to High, and samples nDataAvail (nFault). If it is still Low, the controller returns to the event sequence at the start of this paragraph, otherwise it sets the Idle flag.

In response to Idle, software should enter Host Negotiation mode. Thereafter, it can set HostBusy (nAutoFd) Low, to enter Reverse Idle state, or enter Host Compatible mode (reference IEEE P1284 specification), or conduct a new negotiation.

If software is programmed not to accept all the data that a peripheral has available in this mode, it should first disable the DMA channel, if one is in use, and then wait for DREQ to be 1 and nAck to be 1. Then it should reprogram the controller back to Host Negotiation mode, read the last byte from the IOR, drive HostClk (nStrobe) back to High, and then drive P1284Active (nSelectIn) Low to instruct the peripheral to leave Byte mode.

There are no status interrupts in Host Byte mode.

Peripheral Byte Mode

1. Software should not set this mode until there is reverse data available to send — that is, it should implement the P1284 “reverse idle mode” via software in Peripheral Compatibility/Negotiation mode. The exact sequencing among PtrClk (nAck), nDataAvail (nFault), and AckDataReq (PErr) differs according to whether this mode is entered directly from Negotiation or from reverse idle phase, and is controlled by software. But in either case, before software sets this mode, it should set nDataAvail (nFault) and AckDataReq (PErr) to Low, then after 500 ns, set PtrClk (nAck) to High. When it detects that the host has driven HostBusy (nAutoFd) Low to request data, software should set this mode, which sets the DREQ and Idle flags.
2. In this mode, as long as P1284Active (nSelectIn) remains High, the controller drives PIA27-20 as outputs, regardless of the contents of register E2. When software, or a DMA channel, writes the first byte to the Output Holding Register, the controller immediately transfers the byte to the Input/Output Register, clears Idle but negates DREQ only momentarily, to request another byte from software, or the DMA channel.
3. After each byte is transferred to the IOR, the controller waits 500 ns data setup time (as controlled by the PART register) before driving PtrClk (nAck) Low, and thereafter waits for the host to drive HostBusy (nAutoFd) High.

When this occurs, if software, or the DMA channel, has not written more data to the Output Holding Register, that is, if DREQ is still set, the controller sets the Idle flag and waits for software or the DMA channel to do so. If software, or the DMA channel, then writes data to the Output Holding Register, the controller clears DREQ and Idle. When there is data in the OHR and DREQ is 0, this guarantees that it is appropriate to keep nDataAvail (nFault), and AckDataReq (PErr) Low to indicate that more data is available, and the controller drives PtrClk (nAck) back to High. The controller then waits for a rising edge on HostClk (nStrobe), and then for the host to drive HostBusy (nAutoFd) Low, at which time it transfers the byte from the OHR to the Output Register, sets DREQ, and then it returns to the event sequence at the start of this paragraph.

While this mode is in effect, software should monitor the interface for two conditions:

Case 1: Idle set and no more data to send, or

Case 2: P1284Active (nSelectIn) Low.

In Case #1, the software should write zero to register E3 to keep PIA27-20 outputs momentarily, and then set the mode back to Peripheral Compatibility, so that the interface is fully under software control, set nDataAvail (nFault) and AckDataReq (PErr) High to signify no more data, wait 500 ns, and set PtrClk (nAck) back to High. When HostBusy goes back to Low, the software should set PIA27-20 back to inputs.

In Case #2, if a falling edge on P1284Active happens any time other than between a rising edge on HostClk (nStrobe), and the next falling edge on HostBusy (nAutoFd), the controller sets the IIIOp bit to notify software that an immediate Abort is in order, in which case software should immediately enter Peripheral Compatibility/Negotiation Mode. If P1284Active goes Low, but IIIOp is not set, meaning that the Host negated P1284Active in a “legal” manner, software should enter Peripheral Inactive Mode for the duration of the “return to Compatibility Mode”, and then enter Peripheral Compatibility/Negotiation Mode.

Status interrupts in Peripheral Byte Mode include rising and falling edges on P1284Active (nSelectIn) and nInit.

Z80185 BIDIRECTIONAL CENTRONICS P1284 CONTROLLER (Continued)

Host ECP Forward Mode

1. After a negotiation for ECP mode, "host" software should remain in Negotiation mode so that it has complete control of the interface, until one of two situations occurs. If software has data to send, it should optionally program the DMA channel to provide the data, and then set this mode. Alternatively, if software has no data to send and it detects that `nPeriphRequest` (`nFault`) has gone Low, indicating the peripheral is requesting reverse transfer, it should set `PIA27-20` as inputs, wait 500 ns, drive `nReverseRequest` (`nInIt`) to Low to indicate a reverse transfer, and then set Host ECP Reverse mode. In other words, software should handle all aspects of ECP mode, other than active data transfer sequences.
2. Setting this mode configures `PIA27-20` as outputs regardless of the contents of register `E2`. On entry to this mode, the controller sets `Idle` and `DREQ` to request a byte from software or a DMA channel, but these settings do not cause an interrupt request.
3. If software, or a DMA channel, writes data to the Output Holding Register while the Input/Output Register is empty, the controller immediately transfers the byte to the IOR, clears `Idle`, and negates `DREQ` only momentarily, to request another byte.
4. In this mode, the alternate address for the Output Holding Register allows software to send a "channel address" or an RLE count value. Such bytes are typically written by software rather than a DMA channel. Writing to the alternate address loads the OHR and clears `DREQ`, like writing to the primary address, but clears a ninth bit that is set when software, or a DMA channel, writes to the primary address. A similar ninth bit is associated with the Input/Output Register, from which it drives the `HostAck` (`nAutoFd`) line.
5. As each nine bits arrive in the IOR and thus out onto `PIA27-20` and `HostAck` (`nAutoFd`), the controller waits one PHI clock and then drives `HostClk` (`nStrobe`) to Low. It then waits for the peripheral to drive `PeriphAck` (`Busy`) to High, after which it drives `HostClk` (`nStrobe`) back to High. Then it waits for the peripheral to drive `PeriphAck` (`Busy`) back to Low. When this has happened, if software or a DMA channel has written a new byte to the Output Holding Register, and thus cleared `DREQ`, the controller transfers the byte to the IOR, sets `DREQ` again, and returns to the event sequence at the start of this paragraph. Otherwise, it returns to the event sequence at the start of paragraph #3. If software, or a DMA channel, does not provide a new byte for the time indicated in the `PART` register, the controller sets the `Idle` flag.
6. While this mode is in effect, software should monitor for the condition "Idle and no more data left to send", and/or `nPeriphRequest` (`nFault`) Low. Host software has complete freedom as to whether to honor the peripheral's reverse request on `nFault` while it has data to send. When there is no more data, software can set Host Negotiation mode to have full control of the interface, and if requested can drive `P1284Active` (`nSelectIn`) to Low in order to terminate ECP mode, or can set Host ECP Reverse mode, wait 500 ns, and drive `nReverseRequest` (`nInIt`) to Low.

Status interrupts in Host ECP Forward mode include rising and falling edges on `nPeriphRequest` (`nFault`).

Peripheral ECP Forward Modes

1. After a negotiation for ECP mode, "peripheral" software should remain in Compatibility/Negotiation mode with P1284Active (nSelectIn) High, so that it has complete control of the interface, though when it detects the host drive HostAck (nAutoFd) Low for the second time, it should then set nAckReverse (PErr) High. If software has data to send, it should drive nPeriphRequest (nFault) Low at the same time, and optionally program a DMA channel to provide the data. Whether or not it has data to send, software should then set one of the two ECP Forward modes.
2. In these modes, the controller configures PIA27-20 as inputs regardless of the contents of register E2. On entry to one of these modes, the controller clears the Idle bit, if it had been set.
3. For each byte, the controller waits for the host to drive HostClk (nStrobe) to Low. When HostClk (nStrobe) is Low and software, or the DMA channel, has taken any previous byte and thus cleared DREQ, operation diverges into four cases depending on the state of HostAck (nAutoFd), the mode, the MSbit of the data, and the state of an internal 7-bit Run-Length Encoding (RLE) counter.
5. Thereafter, the controller waits for the host to drive HostClk (nStrobe) back to High, at which time it drives PeriphAck (Busy) back to Low, and returns to the event sequence at the start of paragraph #3.
6. If HostAck (nAutoFd) is Low, and PIA27 is High, the byte is a "channel address." In this case, or when PIA27 is Low and the mode is "software RLE handling," the controller captures the data from PIA27-20 into the Input/Output Register, leaves DREQ cleared to keep a DMA channel from storing the byte, and sets the Idle bit, which it does not otherwise set while in this mode. Software should respond to this condition by reading the byte from the PIA 2 data register E3. Software can then do whatever else is needed to handle the situation, and then set Busy High. Thereafter the controller clears Idle, waits (if necessary) for the host to drive HostClk (nStrobe) back to High, and then drives PeriphAck (Busy) back to Low and returns to the event sequence at the start of paragraph #3.

While this mode is set, if data to send becomes available, software should drive nPeriphRequest (nFault) Low to alert the host of this fact. Also software should monitor the controller for either of two conditions:

- If HostAck (nAutoFd) is High, indicating that this byte is neither an RLE value, nor a Channel Address, the controller captures the data from PIA27-20 into the Input/Output Register, sets DREQ to request software, or the DMA channel, to take this byte, and drives PeriphAck (Busy) High. If the RLE counter is zero, the controller waits (if necessary) for the host to drive HostClk (nStrobe) back to High, after which it drives PeriphAck (Busy) back to Low and returns to the event sequence at the start of paragraph #3. If the RLE counter is non-zero, the controller waits for software, or a DMA channel, to read the byte from the Input/Output Register, negates DREQ only momentarily, and decrements the RLE counter. It does this until the RLE counter is zero, at which point it proceeds as described above. Thus an RLE value of "n" results in the next byte being provided to software, or a DMA channel "n+1" times.
- a. If the host drives nReverseRequest (nInit) Low in response to nPeriphRequest (nFault) Low, software should drive nAckReverse (PErr) Low, optionally program a DMA channel to provide the data, and set Peripheral ECP Reverse mode.
 - b. If P1284Active (nSelectIn) goes Low, the controller sets the IIIOp bit in PARC, if this occurs between the time the host drives HostClk (nStrobe) Low, and when the controller subsequently drives PeriphAck (Busy) back to Low, in which case software should immediately enter Peripheral Compatibility/Negotiation mode. If P1284Active goes Low, but IIIOp stays zero, indicating a "legal" termination, software should enter Peripheral Inactive mode and sequence the nAckReverse (PErr), PeriphAck (Busy), PeriphClk (nAck), nPeriphRequest (nFault), and Xflag (Select) lines to leave ECP mode.
4. If HostAck (nAutoFd) is Low and the MS bit of the byte is zero (PIA27 is Low), the byte is an RLE repeat count. If the mode is "hardware RLE expansion," the controller transfers (the seven LS bits of) it to the RLE counter, leaves DREQ cleared, and drives PeriphAck (Busy) High.

Status interrupts in Peripheral ECP Forward mode include rising and falling edges on P1284Active (nSelectIn) and nReverseRequest (nInit).

Z80185 BIDIRECTIONAL CENTRONICS P1284 CONTROLLER (Continued)**Host ECP Reverse Modes**

1. In these modes the controller configures PIA27-20 as inputs, regardless of the contents of register E2. On entry to one of these modes, the controller clears the Idle bit, if it had been set.
2. For each byte, the controller waits for the peripheral to drive PeriphClk (nAck) Low. When this happens, and software, or the DMA channel, has taken any previous byte from the Input/Output Register and thus cleared DREQ, operation diverges into four cases, depending on the state of PeriphAck (Busy), the mode, the LS bit of the data, and the state of an internal 7-bit RLE counter.

If PeriphAck (Busy) is High, indicating that this byte is neither an RLE value nor a Channel Address, the controller captures the data from PIA27-20 in the IOR, sets DREQ to notify software, or the DMA channel to take the byte, and drives HostAck (nAutoFd) High. If the RLE counter is zero, the controller then waits (if necessary) for the peripheral to drive PeriphClk (nAck) back to High, after which it drives HostAck (nAutoFd) back to Low and returns to the event sequence at the start of paragraph #2. If the RLE counter is non-zero, the controller waits for software, or the DMA channel, to read the byte from the IOR, negates DREQ only momentarily, and decrements the RLE counter. It does this until the RLE counter is zero, at which point it proceeds as described above. Thus an RLE value of "n" results in the next byte being provided to software or a DMA channel "n+1" times.
3. If PeriphAck (Busy) is Low, and the MSbit of the byte is zero (PIA27 is Low), the byte is an RLE repeat count. If the mode is "hardware RLE expansion," the controller transfers (the seven LSbits of) it to the RLE counter, leaves DREQ cleared, and drives HostAck (nAutoFd) High. Thereafter the controller waits for the peripheral to drive PeriphClk (nAck) back to High, at which time it drives HostAck (nAutoFd) back to Low and returns to the event sequence at the start of paragraph #2.
4. If PeriphAck (Busy) is Low, and the MSbit of the byte is 1 (PIA27 is High), the byte is a "channel address". In this case, or when the LSbit is zero, but the mode is "software RLE handling," the controller captures the data from PIA27-20 in the IOR, leaves DREQ cleared, to keep a DMA channel from storing the byte, and sets Idle, which it does not otherwise set in this mode. Software should respond to this condition by reading the byte from the PIA 2 data register E3, reprogramming a DMA channel, if necessary, and doing whatever else is needed to handle the channel address, and finally setting HostAck (nAutoFd) High. Thereafter the controller clears Idle, waits for the peripheral to drive PeriphClk (nAck) back to High, and then drives HostAck (nAutoFd) back to Low, and returns to the start of the event sequence in paragraph #2 above.
5. If data has become available to be sent while this mode is in effect and software elects to send it, it should drive nReverseRequest (nInit) to High, set Host Negotiation mode to take full control of the interface, wait for nAckReverse (PError) to go High, and then set PIA27-20 as outputs.
6. Status interrupts in Host ECP Reverse mode include rising and falling edges on nPeriphRequest (nFault). nPeriphRequest carries a valid "reverse data available" indication during Reverse ECP mode. If so, enable status interrupts during this mode; if not, disable them.

Peripheral ECP Reverse Mode

1. In this mode, as long as `nReverseRequest` (`nInIt`) is Low, and `P1284Active` (`nSelectIn`) is High, the controller drives the contents of the Input/Output Register onto PIA27-20, regardless of the contents of the E2 register. On entry to this mode, the controller sets `Idle`, and sets `DREQ` to request data from software, or a DMA channel.
2. If software, or a DMA channel, writes data to the Output Holding Register while the Input/Output Register is empty, the controller immediately transfers the byte to the IOR, clears `Idle`, and negates `DREQ` only momentarily, to request another byte.
3. In this mode, an alternate address for the Output Holding Register allows software to send a "channel address" or an RLE count value. Such bytes are not typically written by a DMA channel. Writing to this alternate address loads the OHR and clears `DREQ`, the same as writing to the primary address, but clears a ninth bit set when software, or a DMA channel, writes to the primary address. A similar ninth bit is associated with the IOR, and drives the `PeriphAck` (Busy) line in this mode.
4. As each nine bits arrive in the IOR, and thus out onto PIA27-20 and `PeriphAck` (Busy), the controller waits one PHI clock, and then drives `PeriphClk` (`nAck`) Low. It then waits for the host to drive `HostAck` (`nAutoFd`) High, after which it drives `PeriphClk` (`nAck`) back to High. The controller then waits for the host to drive `HostAck` (`nAutoFd`) back to Low. When this has happened, if software, or the DMA channel, has written a new byte to the Output Holding Register, and thus cleared `DREQ`, the controller transfers the byte to the IOR, sets `DREQ` again, and returns to the start of the event sequence in this paragraph. Otherwise, it returns to the event sequence at the start of paragraph #2. If software, or the DMA channel, doesn't provide new data within the time indicated by the PART register, the controller sets the `Idle` bit.
5. While this mode is in effect, software should monitor whether the host drives `nReverseRequest` (`nInIt`) High. If it detects this, it should set the mode back to Peripheral ECP Forward, wait 500 ns and then drive `nAckReverse` (`PError`) back to High, before proceeding as described for Peripheral ECP Forward mode above.
6. Status interrupts in Peripheral ECP Reverse mode include rising and falling edges on `P1284Active` (`nSelectIn`) and `nReverseRequest` (`nInIt`). Since there are no "legal terminations" during the time this mode is set, the controller sets `IIIOP` for any falling edge on `P1284Active` (`nSelectIn`) in this mode.

Z80185 CTC, AND MISCELLANEOUS REGISTERS

The following section describes miscellaneous registers that control the Z80185 configuration, including RAM/ROM registers, Interrupt and various Status and Timer registers.

Register Name	I/O Addr/Access	Register Name	I/O Addr/Access
WSG Chip Select Register	%D8 R/W	EMSCC Control Register	%E8 R/W
PIA1/CTC Pin Select Register	%DE R/W	EMSCC Data Register	%E9 R/W
Interrupt Edge Control	%DF R/W	RAMUBR RAM Upper Boundary Reg	%EA R/W
PIA 1 Data Direction Register	%E0 R/W	RAMLBR RAM Lower Boundary Reg	%EB R/W
PIA 1 Data Register	%E1 R/W	ROM Address Boundary Reg.	%EC R/W
PIA 2 Data Direction Register	%E2 R/W	System Configuration Reg.	%ED R/W
PIA 2 Data Register	%E3 R/W	PIA 2 Data Alternate Address	%EE R/W
CTC Channel 0 Control Register	%E4 R/W	WDT Master Register	%F0 R/W
CTC Channel 1 Control Register	%E5 R/W	WDT Command Register	%F1 WO
CTC Channel 2 Control Register	%E6 R/W		
CTC Channel 3 Control Register	%E7 R/W		

System Configuration Register

This register controls a number of device-level features on the Z80185 and includes the following control bits:

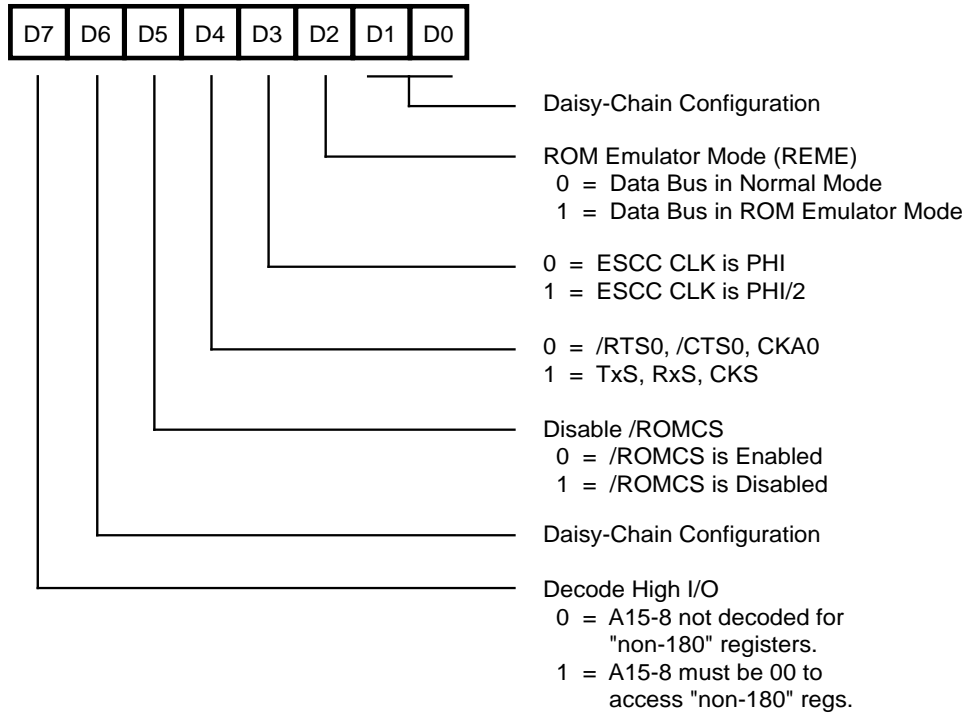

Figure 82. System Configuration Register
(I/O Address %ED)

Z80185 PIA AND MISCELLANEOUS REGISTERS (Continued)**System Configuration Register (Continued)**

Bit 7. *Decode High I/O.* If this bit is 0, as it is after a Reset, A15-8 are not decoded for the registers for which A7-6 are 11, that is, the registers for the EMSCC, CTCs, I/O Ports, Bidirectional Centronics Controller. If this bit is 1, A15-8 must all be zero to access these registers, as for the other registers in the Z80185. When set to 0, this bit is compatible with the Z80181 and Z80182, and allows shorter, and more basic I/O instructions to be used to access these registers. Alternately, when set to 1, this bit allows more extensive off-chip I/O.

Bit 6. *Daisy-Chain Configuration Bit 2.* This bit is described with bits 1-0 below.

Bit 5. *Disable /ROMCS.* When this bit is 1, /ROMCS is forced to High, regardless of the status of the address decode logic. This bit Resets to 0 so that /ROMCS is enabled.

Bit 4. When this bit is 0, the /RTS0/TXS, /CTS0/RXS, and CKA0/CKS pins have the /RTS0, /CTS0 and CKA0 func-

tions, respectively. When this bit is 1, the pins have the TXS, RXS, and CKS functions, and the CSIO facility can be used. When this bit is 1, if ASCI0 is used, the “CTS auto-enable” function must not be enabled. The multiplexing of CKA0 is important only with respect to output — the same external clock could be used for both ASCI0 and the CSIO.

Bit 3. When this bit is 0, the PCLK clock of the EMSCC is the same as the processor’s PHI clock. When this bit is 1, this clock is PHI/2. Set this bit if the PHI clock is too fast for the EMSCC.

Bit 2. *ROM Emulator Mode Enable.* When this bit is 1, read data from on-chip sources is driven onto the D7-D0 pins, as shown in Table 6. This bit resets to 0.

Bits 1-0. These bits, plus bit 6, determine the routing of the on-chip interrupt daisy-chain, and thus the relative interrupt priority of the on-chip interrupt sources on the daisy-chain as shown in Table 5.

Table 5. Interrupt Daisy-Chain Routing

b6	b1	b0	Daisy Chain Configuration
0	0	0	IEI pin -> EMSCC -> CTC -> Bidirectional Centronics Controller -> IEO pin
0	0	1	IEI pin -> EMSCC -> Bidirectional Centronics Controller -> CTC -> IEO pin
0	1	X	IEI pin -> Bidirectional Centronics Controller -> EMSCC -> CTC -> IEO pin
1	0	0	IEI pin -> CTC -> EMSCC -> Bidirectional Centronics Controller -> IEO pin
1	0	1	IEI pin -> CTC -> Bidirectional Centronics Controller -> EMSCC -> IEO pin
1	1	X	IEI pin -> Bidirectional Centronics Controller -> CTC -> EMSCC -> IEO pin

Table 6. Data Bus Direction (Z185 Bus Master)

I/O and Memory Transactions									
	I/O Write to On-Chip Peripherals	I/O Read from On-Chip Peripherals	I/O Write to Off-Chip Peripherals	I/O Read from Off-Chip Peripherals	Write to Memory	Read From On-Chip ROM	Read From Off-Chip Memory	Refresh	Z80185 Idle Mode
Z80185 Data Bus (ROME=0)	Out	Z	Out	In	Out	Z	In	Z	Z
Z80185 Data Bus (ROME=1)	Out	Out	Out	In	Out	Out	In	Z	Z

Interrupt Acknowledge Transaction		
	Intack for On-Chip Peripheral	Intack for Off-Chip Peripheral
Z80185 Data Bus (ROME=0)	Z	In
Z80185 Data Bus (ROME=1)	Out	In

Table 8. Data Bus Direction (Z185 Is Not Bus Master)

I/O and Memory Transactions									
	I/O Write to On-Chip Peripherals	I/O Read from On-Chip Peripherals	I/O Read from Off-Chip Peripherals	I/O Write to On-Chip Peripherals	Write to Memory	Read From On-Chip ROM	Read From Off-Chip Memory	Refresh	Ext. Bus Master is Idle
Z80185 Data Bus (ROME=0)	In	Out	Z	Z	Z	Out	In	Z	Z
Z80185 Data Bus (ROME=1)	In	Out	Z	Z	Z	Out	In	Z	Z

Interrupt Acknowledge Transaction		
	Intack for On-Chip Peripheral	Intack for Off-Chip Peripheral
Z80185 Data Bus (ROME=0)	Out	In
Z80185 Data Bus (ROME=1)	Out	In

Notes:

"Out" means that the Z185 data bus direction is in output mode; "In" means input mode, and "Z" means High impedance. ROME stands for ROM Emulator mode and is the status of the D2 bit in the System Configuration Register.

Z80185 PIA AND MISCELLANEOUS REGISTERS (Continued)

RAM And ROM Registers

Three registers, ROMBR, RAMLBR and RAMUBR, and two pins, /ROMCS and /RAMCS, assist with decoding of ROM and RAM blocks of memory.

RAMUBR (I/O Address %EA)

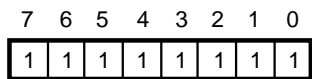

A19-A12 RAMUBR

Figure 83. RAMUBR (I/O Address %EA)

RAMLBR (I/O Address %EB)

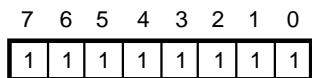

A19-A12 RAMLBR

Figure 84. RAMLBR (I/O Address %EB)

The names RAMUBR and RAMLBR stand for RAM Upper Boundary Range and RAM Lower Boundary Range. These two registers specify the address range for the /RAMCS signal. When accessed, memory addresses are less than, or equal to, the value in the RAMUBR, and greater than, or equal to, the value programmed in the RAMLBR, /RAMCS is asserted.

ROMBR ROM Address Boundary Register

This register specifies the address range for the /ROMCS signal. When an accessed memory address is less than, or equal to, the value programmed in this register, but greater than the size of on-chip ROM (if on-chip ROM is enabled), the /ROMCS signal is asserted.

/ROMCS can be forced to a “1” (inactive state) by setting bit 5 in the System Configuration Register, to allow the user to overlay the RAM area over the ROM area.

ROMBR (I/O Address %EC)

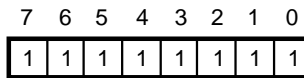

A19-A12 ROMBR

Figure 85. ROMBR (I/O Address %EC)

/RAMCS and /ROMCS are active for accesses by an external master, as well as by the Z80185 processor. If /ROMCS and /RAMCS are programmed to overlap, /ROMCS is asserted and /RAMCS is inactive for addresses in the overlapping region.

Chip Select signals are active for the address range:

/ROMCS: (ROMBR) >= A19-A12 >= Size of On-Chip ROM (if enabled, else 0)

/RAMCS: (RAMUBR) >= A19-A12 >= (RAMLBR)

All three of the above registers are set to “FFh” at Power-On Reset. This means that if on-chip ROM is enabled, /ROMCS is asserted for all addresses above the size of on-chip ROM, if not, /ROMCS is asserted for all addresses. Since /ROMCS takes priority over /RAMCS, the latter will never be asserted until the value in the ROMBR and RAMLBR registers are re-initialized to lower values.

Wait State Generation (WSG)

The Memory Wait Insertion field of the DCNTL register applies to all accesses to memory, and allows insertion of 0-3 wait states. In the Z80185, the WSG Chip Select Register allows individual wait state control for the various types and areas of memory.

WSG Chip Select Register (I/O Address %D8)

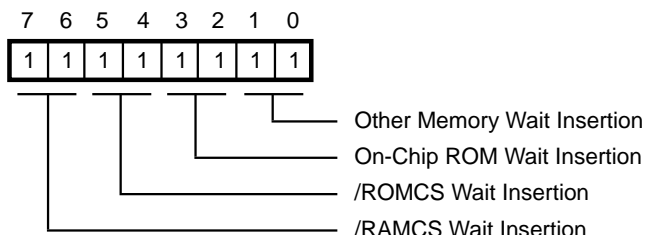

Figure 86. WSG Chip Select Register
(I/O Address %D8)

Bits 7-6. This field controls how many wait states are inserted for accesses to external memory in which /RAMCS is asserted: 00 = none, 01 = 1, 10 = 2, 11 = 4 wait states.

Bits 5-4. This field controls how many wait states are inserted for accesses to external memory in which /ROMCS is asserted, and is encoded like bits 7-6.

Bits 3-2. This field controls how many wait states are inserted for accesses to on-chip ROM, and is encoded like bits 7-6. **Note:** On-chip ROM should be fast enough to support no-wait-state operation at the maximum specified clock rate, but this field is included as a “hedge” against difficulties in this area, as well as to provide timing compatibility in unusual circumstances.

Bits 1-0. This field controls how many wait states are inserted for accesses to external memory in which neither /RAMCS nor /ROMCS is asserted, and is encoded the same as bits 7-6.

All fields in this register Reset to 11. The 4-wait-state feature is included to allow the use of commodity DRAMs with a clock rate at, or near, the maximum.

Note that this facility, and the one in the DCNTL register, both logically OR into the WAIT signal, to allow this register full control of wait states. Bits 7-6 of DCNTL should be programmed to 00.

Z80185 PIA AND MISCELLANEOUS REGISTERS (Continued)

Interrupt Edge Register

Interrupt Edge Register (I/O Address %DF)

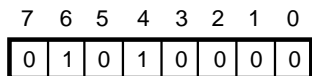

- 0 = /DCD0/CKA0 is /DCD0
1 = /DCD0/CKA0 is CKA0
- Drive Select for pins listed below
0 Select normal drive
1 Select low noise (33%) drive capabilities
- /INT1 Sense/Unlatch
0 in: /INT1 is low
1 in: /INT1 is high
out: unlatch edge detection
- /INT2 Sense/Unlatch
0 in: /INT2 is low
1 in: /INT2 is high
out: unlatch edge detection
- /INT1 Mode Select
0X Normal Level Detect
10 Falling (Neg) Edge Det.
11 Rising (Pos) Edge Det.
- /INT2 Mode Select
0X Normal Level Detect
10 Falling (Neg) Edge Det.
11 Rising (Pos) Edge Det.

Figure 87. Interrupt Edge Register
(I/O Address %DF)

Bits 7-6. These bits control the interrupt capture logic for the /INT2 pin. When these bits are 0X, the /INT2 pin is level sensitive and Low active. When these bits are 10, negative edge detection is enabled. Any falling edge will latch an active Low on the internal /INT2 to the processor. This interrupt must be cleared by writing a 1 to bit 3 of this register. Programming these bits to 11 enables rising edge interrupts to be latched. The latch must be cleared in the same fashion as for a falling edge.

Bits 5-4. These bits control the interrupt capture logic for the external /INT1 pin. When these bits are 0X, the /INT1 pin is level sensitive and Low active. When these bits are 10, negative edge detection is enabled. Any falling edge will latch an active Low on the internal /INT1 to the processor. This interrupt must be cleared by writing a 1 to bit 2 of this register. Programming these bits to 11 enables rising edge interrupts to be latched. The latch must be cleared in the same fashion as for a falling edge.

Bit 3. Software can read this register to sense the state of the /INT2 pin. Writing a 1 to this bit clears the edge detection logic for /INT2.

Bit 2. Software can read this register to sense the state of the /INT1 pin. Writing a 1 to this bit clears the edge detection logic for /INT1.

Bit 1. This bit selects low noise or normal drive for the parallel ports, bidirectional Centronics controller pins, Chip Select pins, and EMSCC pins as follows:

PIA 10-13	/RTS	nFault
PIA 14-16/ZCT0 0-2	/DTR	nInIt
PIA 27-20	TXD	nSelectIn
/ROMCS	/TRXC	nStrobe
/RAMCS	BUSY	PError
/IOCS	nAck	Select
IEO	nAutoFd	

A 1 in this bit selects the low noise option, which is a 33 percent reduction in drive capability. A 0 selects normal drive, and is the default after power-up. Additionally, refer to CPU Register (CCR) for a list of the pins that are programmable for low drive, via the CCR register.

Bit 0. If this bit is 1, the /DCD0/CKA1 pin has the CKA1 function. The pin is always connected to the DCD input of ASCI0, so if this pin is 1, and ASCI0 is used, it should not be programmed to use DCD as a receive auto-enable.

Individual Pin Selection Between PIA1 and CTCs

The assignment of the choice between PIA1 and CTC I/Os is controlled by the PIA1/CTC Pin Select Register (Figure 79).

Bit 7. Reserved, and should be programmed as 0.

Bits 6-4. When the PIA1 data direction register has set the corresponding pins as outputs, for each of these bits that is 0, the pin is driven with the state of the corresponding bit of the PIA 1 Data register, while for each of these bits that

is 1, the associated pin is driven with the indicated CTC output. These bits Reset to 0.

Bits 3-1. These bits control whether the CLK/TRG inputs of CTCs 3-1 are taken from PIA3-1, respectively, or from the ZC/TO outputs of CTC2-0, respectively. These bits do not have any affect on the operating mode of the CTCs.

Bit 0. This bit is reserved and should be programmed as 0. CTC0's CLK/TRG0 input is always connected to the PIA10 pin.

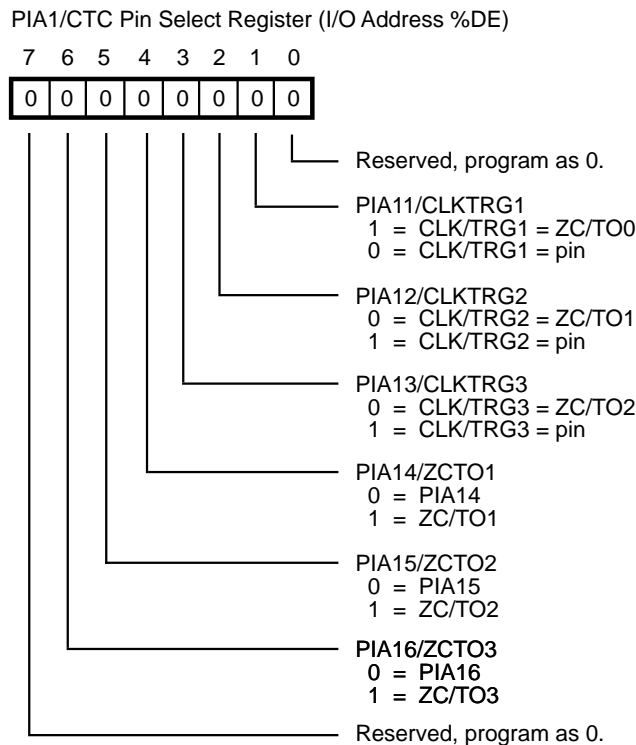

Figure 88. PIA1/CTC Pin Select Register
(I/O Address %DE)

Z80185 PIA AND MISCELLANEOUS REGISTERS (Continued)**CTC Control Registers****Channel Control Byte**

This byte is used to set the operating modes and parameters. Bit D0 must be a 1 to indicate that this is a Control Byte (Figure 82).

The Channel Control Byte register has the following fields:

Bit D7. *Interrupt Enable.* This bit enables the interrupt logic so that an internal INT is generated at zero count. Interrupts are programmed in either mode, and may be enabled or disabled at any time.

Bit D6. *Mode Bit.* This bit, along with bit 3, is used to select either Timer mode or Counter mode (Table 8).

Bit D5. *Prescaler Factor.* This bit selects the prescaler factor for use in the timer mode. Either divide-by-16 or divide-by-256 is available.

Bit D4. *Clock/Trigger Edge Selector.* This bit selects the active edge of the CLK/TRG input pulses.

Bit D3. *Mode Bit.* This bit, along with bit 6, selects either Timer mode or Counter mode (Table 8).

Bit D2. *Time Constant.* This bit indicates that the next byte programmed is time constant data for the downcounter.

Bit D1. *Software Reset.* Writing a 1 to this bit indicates a software reset operation, which stops counting activities until another time constant word is written.

Table 8. CTC Operation Modes

CCW6	CCW3	Operation
0	0	(Auto Start) Timer mode. The prescaler is clocked by PHI, and the counter is clocked by the prescaler. Counting is enabled when the timer constant is loaded.
0	1	Timer with CLK/TRG Trigger. The prescaler is clocked by PHI, and the counter is clocked by the prescaler. Timing starts when the transition specified by D4 is detected on the PIA pin, or for CTC3-1, the ZC/TO output of CTC2-0, respectively.
1	0	Classic Counter mode. The counter is clocked by the PIA pin, or for CTC3-1 the ZC/TO output of CTC-2 respectively.
1	1	Long Counter mode. The prescaler is clocked by the PIA pin, or for CTC3-1 the ZC/TO output of CTC-2, respectively, and the counter is clocked by the prescaler.

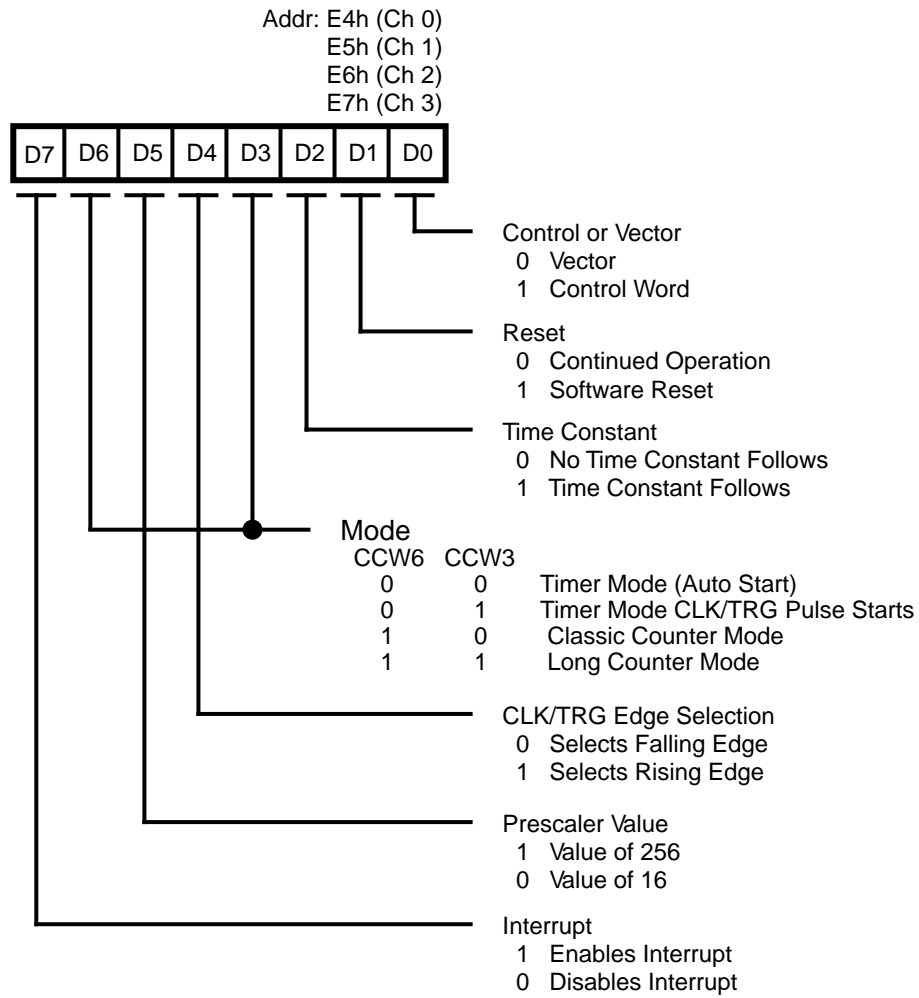

Figure 89. CTC Channel Control Word

Z80185 PIA AND MISCELLANEOUS REGISTERS (Continued)

CTC Control Registers (Continued)

Time Constant

Before a channel can start counting, it must receive a time constant. The time constant value may be anywhere between 1 and 256, with 0 indicating a count of 256 (Figure 90).

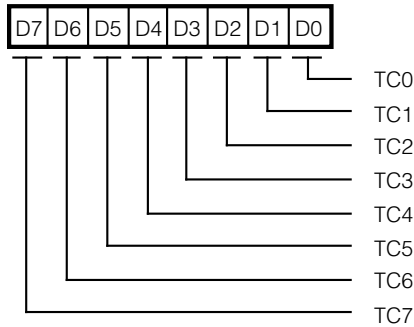

Figure 90. CTC Time Constant

Interrupt Vector

If one or more of the CTC channels have interrupt enabled, then the Interrupt Vector Word should be programmed. Only the five most significant bits of this word are used, bit D0 must be 0. Bits D2-D1 are automatically modified by the CTC channels after responding with an interrupt vector (Figure 91).

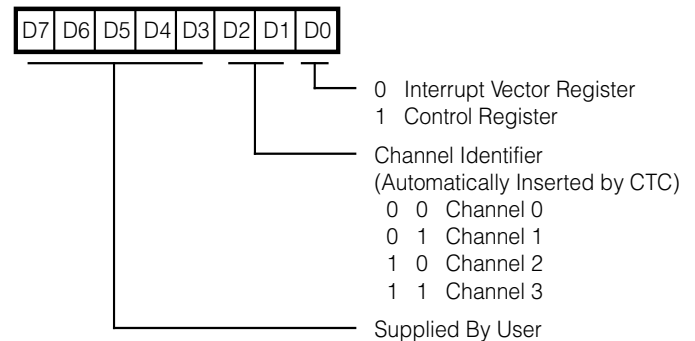

Figure 91. CTC Interrupt Vector

Watch-Dog Timer

The Z80185's Watch-Dog Timer (WDT) facility is identical to Zilog's Z84C15 WDT with the following exceptions:

1. The HALT mode field of the WDT Master Register is not used. Power control is handled as on the Z8S180.
2. Rather than having a separate /WDTOUT output pin, the output of the WDT is logically Low-active-ORed with the /RESET pin. A new register bit controls whether this affects only the processor, by means of an internal logic gate, or whether it also drives the /RESET pin Low in an open-drain manner, so that external logic can be Reset by the WDT as well. The latter is the default state after power-up or Reset.

Watch-Dog Control Registers

Two registers control WDT operations. These are WDT Master Register (WDTMR; I/O Address F0h) and the WDT Command Register (WDTCR; I/O Address F1h). WDT logic has a “double key” structure to prevent accidental disabling of the WDT.

Enabling the WDT. The WDT is enabled by reset, and setting the WDT Enable Bit (WDTMR7) to 1.

Disabling the WDT. The WDT is disabled by clearing WDT Enable bit (WDTR7) to 0 followed by writing “B1h” to the WDT Command Register (WDTCR; I/O Address F1h).

Clearing the WDT. The WDT can be cleared by writing “4Eh” into the WDTCR.

Watch-Dog Timer Master Register (WDTMR; I/O address F0h). This register controls the activities of the Watch-Dog Timer.

Bit D7. Watch-Dog Timer Enable (WDTE). The WDT can be enabled by setting this bit to 1. To disable WDT, write 0 to this bit, followed by writing “B1h” to the WDT Command Register. Upon Power-On Reset, this bit is set to 1 and the WDT is enabled.

Bit D6-D5. WDT Periodic field (WDTP). This 2-bit field determines the desired time period. Upon Power-on reset, this field sets to “11”.

- 00 - Period is (TcC * 2¹⁶)
- 01 - Period is (TcC * 2¹⁸)
- 10 - Period is (TcC * 2²⁰)
- 11 - Period is (TcC * 2²²)

Bit D4. If this bit is 1 and the WDT times out, the Z80185 drives the /Reset pin Low to reset external logic. If this bit is 0, a WDT timer only resets the Z80185 internally.

Bit D3-D0. Reserved. These three bits are reserved and should always be programmed as 0011. Reading these bits returns 0011.

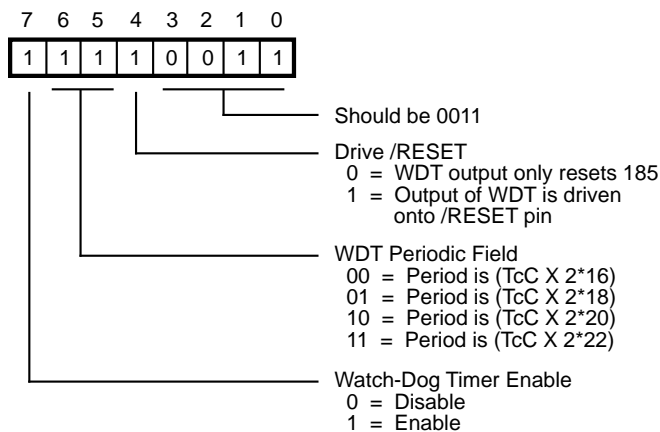

Figure 92. Watch-Dog Timer Master Register
(I/O Address %F0)

Watch-Dog Timer Command Register (WDTCR; I/O Address F1h). This register is Write Only (Figure 93).

Write B1h after clearing WDTE to “0” - Disable WDT
Write 4Eh - Clear WDT

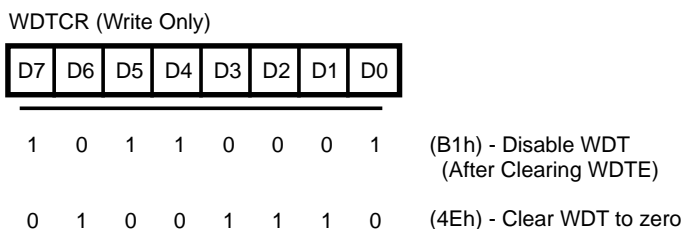

Figure 93. Watch-Dog Timer Command Register

Z80185 PIA AND MISCELLANEOUS REGISTERS (Continued)

Parallel Ports

The Z80185 has two 8-bit bidirectional ports. Each bit is individually programmable for input or output. Each port includes two registers: the Port Direction Control Register and the Port Data Register. The second port also includes an Alternate Address that is used with the Bidirectional Centronics feature.

The data direction register determines which of the PIA27-20 pins are inputs and outputs. When a bit is set to a 1, the corresponding pin is an input. If the bit is 0, then the corresponding bit is an output. These settings can be overridden by the Bidirectional Centronics Controller.

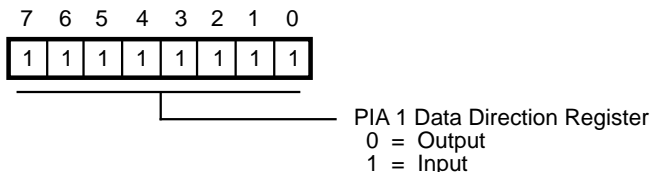

Figure 94. PIA 1 Data Direction Register
(I/O Address %E0)

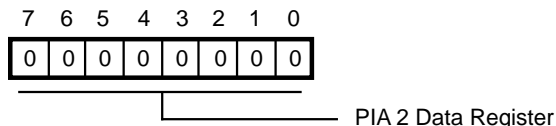

Figure 97. PIA 2 Data Register (I/O Address %E3)

The data direction register determines which of the PIA16-10 pins are inputs and outputs. When a bit is set to 1, the corresponding bit in the PIA 1 Data Register is an input. If the bit is 0, then the corresponding pin is an output. These bits must be set appropriately if these pins are used for CTC inputs and outputs.

When the processor writes to the PIA 2 Data Register, the data is stored in the internal buffer. Any bits that are output are then driven on to the pins. In certain modes of the Bidirectional Centronics Controller, an intermediate register called the Output Holding Register is activated, and the transfer of data from the OHR to the pins is under the control of the controller.

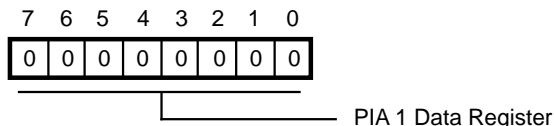

Figure 95. PIA 1 Data Register (I/O Address %E1)

When the processor writes to the PIA 1 Data Register, the data is stored in the internal buffer. Any bits that are output are then driven on to the pins.

When the processor reads the PIA 2 Data Register, the data on the external pins is returned. In certain modes of the Bidirectional Centronics Controller, reading from this address reads the data stored in the port register from PIA27-20 under the control of the controller.

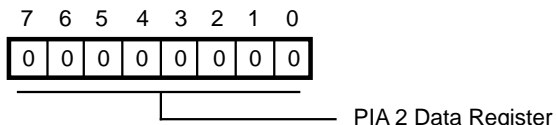

Figure 98. PIA 2 Data Alternate Address
(RW) (I/O Address %EE)

When the processor reads the PIA 1 Data Register, the data on the external pins is returned.

Reading and writing this register is exactly the same as reading and writing address E3 as described above, except that in certain modes of the Bidirectional Centronics Controller, writing to this address sets a "ninth bit" in the opposite sense from writing address E3, and this drives one of the control outputs with the opposite polarity.

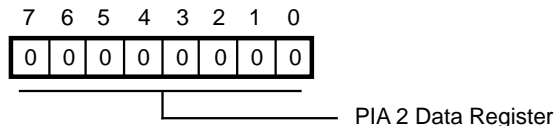

Figure 96. PIA 2 Data Direction Register
(I/O Address %E2)

ELECTRICAL CHARACTERISTICS

The following classification table describes pins in terms of input and output classes. $V_{DD} = 5V \pm 10\%$, unless otherwise noted.

Pin Input/Output Classification

Class "O" output:	Full time / totem pole V_{OL} 0.4V max at $I_{OL} = 2.0$ mA $V_{OH} = V_{DD} - 1.2$ V min at $I_{OH} = 200$ μ A Slew rate 0.33 V/ns min at $C_{LOAD} = 50$ pF $C_{OUT} = 15$ pF max (output or I/O)
Class "3" output:	as "O" except tri-state.
Class "H" output:	as "O" except $V_{OH} = V_{DD} - 0.6$ V min at $I_{OH} = 200$ μ A
Class "D" output:	Open Drain V_{OL} 0.4V max at $I_{OL} = 12$ mA $C_{OUT} = 15$ pF max (output or I/O)
Class "T" output:	Tri-State As Class "O" at $V_{DD} = 3.3V \pm 10\%$ V_{OL} 0.4V max at $I_{OL} = 12$ mA, $V_{DD} = 5V \pm 10\%$ V_{OH} 2.4V min at $I_{OH} = 12$ mA, $V_{DD} = 5V \pm 10\%$ Output impedance 45 ohms max Slew rate 0.05 - 0.40 V/ns (C_{LOAD} not stated by IEEE) $C_{OUT} = 15$ pF max (output or I/O)
Class "I" input:	V_{IL} 0.8V max at $V_{DD} = 5V \pm 10\%$ V_{IL} 0.6V max at $V_{DD} = 3.3V \pm 10\%$ V_{IH} 2.0V min $I_i \pm 10$ μ A max, $V_i = 0$ to 5V (includes leakage if I/O) $C_{IN} = 5$ pF max (if input only, see output type if I/O) Inputs of this type include Weak Latch circuits.
Class "R" input:	V_{IL} 0.6V max V_{IH} $V_{DD} - 0.6$ min at $V_{DD} = 5V \pm 10\%$ V_{IH} $V_{DD} - 0.3$ min at $V_{DD} = 3.3V \pm 10\%$ $I_i \pm 10$ μ A max, $V_i = 0$ to 5V $C_{IN} = 5$ pF max
Class "S" input:	V_{IL} 0.8V max at $V_{DD} = 5V \pm 10\%$ V_{IL} 0.6V max at $V_{DD} = 3.3V \pm 10\%$ V_{IH} 2.0V min Hysteresis 0.2V min $I_i \pm 20$ μ A max, $V_i = 0.8$ to 2V (includes leakage if I/O) Inputs of this type include Weak Latch circuits.

ELECTRICAL CHARACTERISTICS (Continued)

The following table shows the characteristics of each pin in terms of the above classifications. A dash "-" in the input or output column indicates the pin does not have that function.

Table 9. Pin Classification Characteristics

Pin	Input Class	Output Class	Pin	Input Class	Output Class
/BUSREQ	I	-	Busy	S	T
/CTS	I	-	CKA0/CKS	I	3
/CTS0/RxS	I	-	D0-D7	I	3
/DCD	I	-	EXTAL	R	-
/DCD0/CKA1	I	3	IEI	I	-
			IEO	-	O
/DTR	-	O			
/HALT	-	O	nAck	S	T
/INT0	I	D	nAutoFd	S	T
/INT1	I	-	nFault	S	T
/INT2	I	-	nInit	S	T
/IOCS	-	O	nSelectIn	S	T
			nStrobe	S	T
/IORQ	I	3			
/M1	I	3	PErrror	S	T
/MREQ	I	3	PHI	-	H
/NMI	R	-	PIA13-10/CLKTRG3-0	I	3
/RAMCS	-	O	PIA15-13/ZCTO2-0	I	3
/RD	I	3	PIA27-20	S	T
			RXA0	I	-
/RESET	R	D			
/RFSH	-	O	RXA1	I	-
/ROMCS	-	O	RXD	I	-
/RTS	-	O	/ST	-	O
/RTS0/TxS	-	O	Select	S	T
			TOUT//DREQ	I	O
/RTXC	I	3			
/TRXC	I	3	TXA0	-	O
/WAIT	I	D	TXA1	-	O
/WR	I	3	TXD	-	O
A0-A19	I	3	XTAL	-	O

PACKAGE INFORMATION

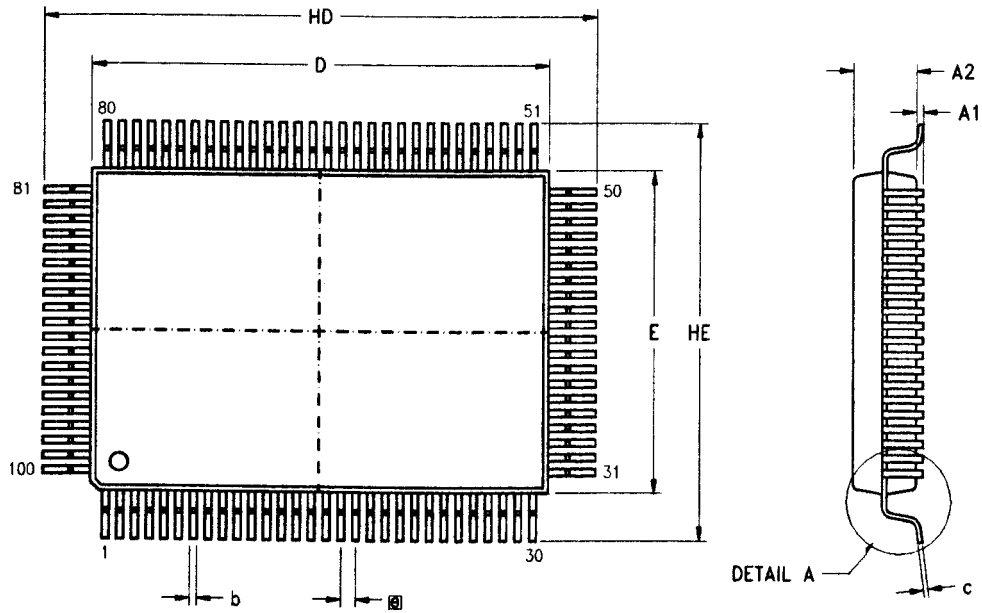

SYMBOL	MILLIMETER		INCH	
	MIN	MAX	MIN	MAX
A1	0.10	0.30	.004	.012
A2	2.60	2.80	.102	.110
b	0.25	0.40	.010	.016
c	0.13	0.20	.005	.008
HD	23.70	24.15	.933	.951
D	19.90	20.10	.783	.791
HE	17.70	18.15	.697	.715
E	13.90	14.10	.547	.555
e	0.65 TYP		.0256 TYP	
L	0.70	1.10	.028	.043

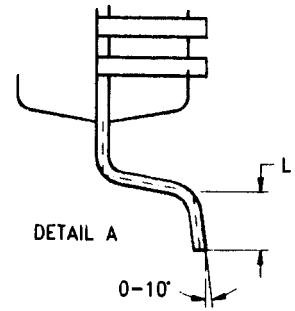

- NOTES:
 1. CONTROLLING DIMENSIONS : MILLIMETER
 2. MAX COPLANARITY : .10
 .004

100-Pin QFP Package Diagram

ORDERING INFORMATION

Z80185 (ROM Version)

20 MHz	33 MHz
Z8018520FSC	Z8018533FSC

Z80195 (ROMless Version)

20 MHz	33 MHz
Z8019520FSC	Z8019533FSC

For fast results, contact your local Zilog sales office for assistance in ordering the part(s) desired.

Package:

F = Plastic Quad Flatpack

Temperature:

S = 0°C to +70°C

Speeds:

20 = 20 MHz
33 = 33 MHz

Environmental:

C = Plastic Standard

Example:

Z 80185 20 F S C is a Z80185, 20 MHz, QFP, 0°C to +70°C, Plastic Standard Flow

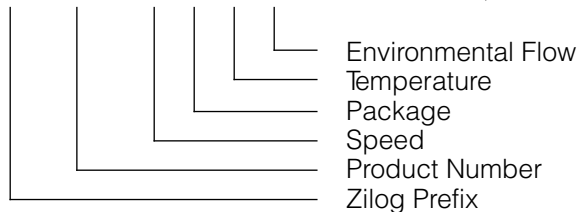

© 1997 by Zilog, Inc. All rights reserved. No part of this document may be copied or reproduced in any form or by any means without the prior written consent of Zilog, Inc. The information in this document is subject to change without notice. Devices sold by Zilog, Inc. are covered by warranty and patent indemnification provisions appearing in Zilog, Inc. Terms and Conditions of Sale only. Zilog, Inc. makes no warranty, express, statutory, implied or by description, regarding the information set forth herein or regarding the freedom of the described devices from intellectual property infringement. Zilog, Inc. makes no warranty of merchantability or fitness for any purpose. Zilog, Inc. shall not be responsible for any errors that may appear in this document. Zilog, Inc. makes no commitment to update or keep current the information contained in this document.

Zilog's products are not authorized for use as critical components in life support devices or systems unless a specific written agreement pertaining to such intended use is executed between the customer and Zilog prior to use. Life support devices or systems are those which are intended for surgical implantation into the body, or which sustains life whose failure to perform, when properly used in accordance with instructions for use provided in the labeling, can be reasonably expected to result in significant injury to the user.

Zilog, Inc. 210 East Hacienda Ave.
Campbell, CA 95008-6600
Telephone (408) 370-8000
Telex 910-338-7621
FAX 408 370-8056
Internet: <http://www.zilog.com>