

P1750A/SOS SINGLE CHIP, 20MHz to 30MHz, CMOS/SOS SPACE PROCESSOR



FEATURES

- Implements the MIL-STD-1750A Instruction Set Architecture
- CMOS/SOS Processor with 32 and 48-Bit Floating Point Arithmetic
- Integer DAIS Mix Performance
3.0 MIPS at 30 MHz
- Available with Class S type manufacturing, screening, and testing
- SOS Insulated substrate technology provides absolute latch up immunity and excellent SEU tolerance
- Total Dose \geq 100 Krads (Si)
- 20, 25, and 30 MHz operation over the Military Temperature Range
- Extensive Error and Fault Management and Interrupt Capability
- Built-In Self Test
- 24 User Accessible Registers
- Single 5V \pm 10% Power Supply
- TTL Signal Level compatible Inputs and Outputs
- Multiprocessor and Co-processor capability
- Built-In Function (BIF) for User Defined Instructions
- Two programmable Timers
- SOS devices are fully interchangeable with application-proven CMOS P1750A Processors; SMD 5962-87665
- Available in:
 - 68-Lead Quad Pack (Leaded Chip Carrier) with Optional Gull Wing



GENERAL DESCRIPTION

The PACE1750A is a general purpose, application-proven, single chip, 16-bit CMOS microprocessor designed for high performance floating point and integer arithmetic, with extensive real time environment support. It offers a variety of data types, including bits, bytes, 16-bit and 32-bit integers, and 32-bit and 48-bit floating point numbers. It provides 13 addressing modes, including direct, indirect, indexed, based, based indexed and immediate long and short, and it can access 2 MWords of segmented memory space (64 KWords segments without use of a MIL-STD-1750A MMU).

The PACE1750A offers a well-rounded instruction set with 130 instruction types, including a comprehensive integer, floating point, integer-to-floating point and floating point-to-integer set, a variety of stack manipulation instructions, high level language support instructions such as Compare Between Bounds and Loop Control Instructions. It also offers some unique instructions such as vectored I/O, supports executive and user modes, and provides an escape mechanism which allows user-defined instructions using a coprocessor. The instruction set is fully compliant with MIL-STD-1750A.

The chip includes 16 general purpose registers, 8 other user-accessible registers, and an array of real time application support resources, such as 2 programmable timers, a complete interrupt controller supporting 16 levels of prioritized internal and external interrupts, and a faults and exceptions handler controlling internally and externally generated faults.

The P1750A uses a single multiplexed 16-bit parallel bus. Status signals are provided to determine whether the processor is in the memory or I/O bus cycle, reading and writing, and whether the bus cycle is for data or instructions.

The basic bus cycle is 4 clocks long. The P1750A will extend the cycle by insertion of wait states in the address and data phases (in response to RDYA and RDYD signals, respectively) and will hold the machine in HI-Z if this CPU has not acquired the bus. A typical non-bus cycle is three clocks long. However, variable length cycles are used for such repetitive operations as multiply, divide, scale and normalize, reducing significantly the number of CPU CLOCKS per operation step and resulting in very fast integer and floating point execution times.

ABSOLUTE MAXIMUM RATINGS¹

Supply Voltage Range	-0.5V to 7.0V
Input Voltage Range	-0.5V to V _{CC} + 0.5V
Storage Temperature Range	-65°C to + 150°C
Input Current Range	-30mA to +5mA
Voltage Applied to Inputs	-0.5V to V _{CC} + 0.5V
Current Applied to Outputs ³	150 mA
Maximum Power Dissipation ²	1.5W
Operating worst case power dissipation (outputs open):	
0.5W	at 20MHz
0.6W	at 25MHz
0.7W	at 30MHz
Lead Temperature Range (soldering 10 seconds)	300°C
Thermal resistance, junction-to-case (θ_{JC}): Packages QL and QG	8°C/W

NOTES:

1. Stresses above the absolute maximum rating may cause permanent damage to the device. Extended operation at the maximum levels may degrade performance and affect reliability.

2. Must withstand the added power dissipation due to short circuit test e.g., I_{OS}

3. Duration one second or less.

RADIATION HARDNESS

Total Dose - (All specification still within limits)	> 1 x 10 ⁵ Rad (Si) [1]
Neutron Hardness	1 x 10 ¹⁵ neutrons/cm ² [2]
Single Event Upset	> 9 x 10 ⁻¹⁰ errors per day [3]
Radiation Induced Latch Up	Absolute immunity [4]

NOTES:

[1] Tested MIL-STD-883 TM 1019

[2] CMOS/SOS is a majority carrier technology and is therefore unaffected. CMOS/SOS typically withstands neutron radiation to > 10¹⁵ (limit of available test equipment). Testing waived, MIL-STD-883 TM 5005

[3] Tested at Brookhaven National Laboratory

[4] Physically impossible for SOS device to suffer destructive latch up from natural space ionizing radiation.

RECOMMENDED OPERATING CONDITIONS

Supply Voltage Range	4.5V to 5.5V
Case Operating Temperature Range	-55°C to +125°C

DC ELECTRICAL SPECIFICATIONS (Over recommended operating conditions)

Symbol	Parameter		Min	Max	Unit	Conditions ¹	
V _{IH}	Input HIGH Level Voltage		2.0	V _{CC} + 0.5	V		
V _{IL}	Input LOW Level Voltage ²		-0.5	0.8	V		
V _{OH}	Output HIGH Level Voltage		2.4		V	V _{CC} = 4.5V	I _{OH} = -8.0mA
			V _{CC} - 0.2		V	V _{CC} = 4.5V	I _{OH} = -300μA
V _{OL}	Output LOW Level Voltage			0.5	V	V _{CC} = 4.5V	I _{OL} = 8.0mA
				0.2	V	V _{CC} = 4.5V	I _{OL} = 300μA
I _{IH1}	Input HIGH Level Current, except I _{B0} - I _{B15} , $\overline{\text{BUS BUSY}}$, $\overline{\text{BUS LOCK}}$			300	μA	V _{IN} = V _{CC} , V _{CC} = 5.5V	
I _{IH2}	Input HIGH Level Current, I _{B0} - I _{B15} , $\overline{\text{BUS BUSY}}$, $\overline{\text{BUS LOCK}}$			100	μA	V _{IN} = V _{CC} , V _{CC} = 5.5V	
I _{IL1}	Input LOW Level Current, except I _{B0} - I _{B15} , $\overline{\text{BUS BUSY}}$, $\overline{\text{BUS LOCK}}$			-50	μA	V _{IN} = GND, V _{CC} = 5.5V	
I _{IL2}	Input LOW Level Current, I _{B0} - I _{B15} , $\overline{\text{BUS BUSY}}$, $\overline{\text{BUS LOCK}}$			-50	μA	V _{IN} = GND, V _{CC} = 5.5V	
I _{OZH}	Output Three-State Current			50	μA	V _{OUT} = 2.4V, V _{CC} = 5.5V	
I _{OZL}	Output Three-State Current			-50	μA	V _{OUT} = 0.5V, V _{CC} = 5.5V	
I _{CCQC}	Quiescent Power Supply Current (CMOS Input Levels)			25	mA	V _{IN} < 0.2V or < V _{CC} - 0.2V, f = 0MHz, Outputs Open, V _{CC} = 5.5V	
I _{CCQT}	Quiescent Power Supply Current (TTL Input Levels)			100	mA	V _{IN} < 3.4V, f = 0MHz, Outputs Open, V _{CC} = 5.5V	
I _{CCD}	Dynamic Power Supply Current	20 MHz		90	mA	V _{IN} = 0V to V _{CC} , tr = tf = 2.5 ns, Outputs Open,	
		25 MHz		100	mA	V _{CC} = 5.5V	
		30 MHz		125	mA		
I _{OS}	Output Short Circuit Current ³		-25		mA	V _{OUT} = GND, V _{CC} = 5.5V	
C _{IN}	Input Capacitance			10	pF		
C _{OUT}	Output Capacitance			15	pF		
C _{I/O}	Bi-directional Capacitance			15	pF		

Notes

- 4.5V ≤ V_{CC} ≤ 5.5V, -55°C ≤ T_C ≤ +125°C. Unless otherwise specified, testing shall be conducted at worst-case conditions.
- V_{IL} = -3.0V for pulse widths less than or equal to 20ns.
- Duration of the short should not exceed one second; only one output may be shorted at a time.

SIGNAL PROPAGATION DELAYS^{1,2}

Symbol	Parameter	20 MHz		25 MHz		30 MHz		Unit
		Min	Max	Min	Max	Min	Max	
$t_{C(BR)L}$	BUS REQ		33		30		27	ns
$t_{C(BR)H}$	BUS REQ		33		30		27	ns
$t_{BGV(C)}$	BUS GNT setup	5		5		5		ns
$t_{C(BG)X}$	BUS GNT hold	5		5		5		ns
$t_{C(BB)L}$	BUS BUSY LOW		38		33		24	ns
$t_{C(BB)H}$	BUS BUSY HIGH		38		33		24	ns
$t_{BBV(C)}$	BUS BUSY setup	5		5		5		ns
$t_{C(BB)X}$	BUS BUSY hold	5		5		5		ns
$t_{C(BL)L}$	BUS LOCK LOW		38		34		32	ns
$t_{C(BL)H}$	BUS LOCK HIGH		38		34		32	ns
$t_{BLV(C)}$	BUS LOCK setup	5		5		5		ns
$t_{C(BL)X (IN)}$	BUS LOCK hold	5		5		5		ns
$t_{C(ST)V}$	M/ \overline{IO} , R/ \overline{W} Status		32		28		25	ns
$t_{C(ST)V}$	AS ₀ -AS ₃ , AK ₀ -AK ₃ , D/I Status		27		23		21	ns
$t_{C(ST)X}$	AS ₀ -AS ₃ , AK ₀ -AK ₃ , D/I Status, M/ \overline{IO} , R/ \overline{W}	0		0		0		ns
$t_{C(SA)H}$	STRBA HIGH		24		20		18	ns
$t_{C(SA)L}$	STRBA LOW		24		20		18	ns
$t_{SAL(IBA)X}$	Address hold from STRBA LOW	5		5		5		ns
$t_{RAV(C)}$	RDYA setup	5		5		5		ns
$t_{C(RA)X}$	RDYA hold	5		5		5		ns
$t_{C(SDW)L}$	STRBD LOW write		24		20		18	ns
$t_{C(SD)H}$	STRBD HIGH		24		20		18	ns
$t_{FC(SDR)L}$	STRBD LOW read		24		20		18	ns
$t_{SDRH(IBD)X}$	STRBD HIGH	0		0		0		ns
$t_{SDWH(IBD)X}$	STRBD HIGH	28		28		28		ns
$t_{SDL(SD)H}$	STRBD write	32		32		32		ns
$t_{RDV(C)}$	RDYD setup	5		5		5		ns
$t_{C(RD)X}$	RDYD hold	5		5		5		ns
$t_{C(IBA)V}$	IB ₀ -IB ₁₅		36		32		28	ns
$t_{FC(IBA)X}$	IB ₀ -IB ₁₅	0		0		0		ns
$t_{IBDRV(C)}$	IB ₀ -IB ₁₅ setup	10		10		10		ns
$t_{C(IBD)X}$	IB ₀ -IB ₁₅ hold (read)	10		10		10		ns
$t_{C(IBD)X}$	Data valid out (write)	0		0		0		ns

SIGNAL PROPAGATION DELAYS^{1,2} (continued)

Symbol	Parameter	20 MHz		25 MHz		30 MHz		Unit
		Min	Max	Min	Max	Min	Max	
$t_{FC(IBD)V}$	IB ₀ -IB ₁₅		34		34		32	ns
$t_{C(SNW)}$	SNEW		34		30		28	ns
$t_{FC(TGO)}$	TRIGORST		34		30		28	ns
$t_{RSTL(DMA ENL)}$	DMA enable		44		40		38	ns
$t_{C(DME)}$	DMA enable		44		40		38	ns
$t_{FC(NPU)}$	Normal power up		44		40		38	ns
$t_{C(ER)}$	Clock to major error unrecoverable		60		55		52	ns
$t_{RSTL(NPU)}$	RESET		50		45		40	ns
$t_{REQV(C)}$	Console request	0		0		0		ns
$t_{C(REQ)X}$	Console request	10		10		10		ns
$t_{FV(BB)H}$	Level sensitive faults	5		5		5		ns
$t_{BBH(F)X}$	Level sensitive faults	5		5		5		ns
$t_{IRV(C)}$	IOL _{1,2} INT user interrupt (0-5) setup	0		0		0		ns
$t_{C(IR)X}$	Power down interrupt level sensitive hold	15		15		15		ns
$t_{RSTL}(t_{RSTH})$	Reset pulse width	25		25		20		ns
$t_{C(XX)Z}$	Clock to three-state		24		20		18	ns
$t_{f(F)}, t_{1(1)}$	Edge sensitive pulse width	5		5		5		ns
t_r, t_f	Clock rise and fall		5		5		5	ns

Notes

1. $4.5V \leq V_{CC} \leq 5.5V$, $-55^\circ C \leq T_C \leq +125^\circ C$. Unless otherwise specified, testing shall be conducted at worst-case conditions.
2. All timing parameters are composed of Three elements. The first "t" stands for timing. The second represents the "from" signal. The third in parentheses indicates "to" signal. When the CPU clock is one of the signal elements, either the rising edge "C" or the falling edge "FC" is referenced. When other elements are used, an additional suffix indicates the final logic level of the signal. "L" - low level, "H" - high level, "V" - valid, "Z" - high impedance, "X" - don't care, "LH" - low to high, "ZH" - high impedance to high, "R" - read cycle, and "W" - write cycle.
3. Functional test shall consist of the same functional test used when testing the equivalent bulk CMOS, MIL-STD-883 Compliant, Class B SMD 5962-87665 device.

MINIMUM WRITE BUS CYCLE TIMING DIAGRAM

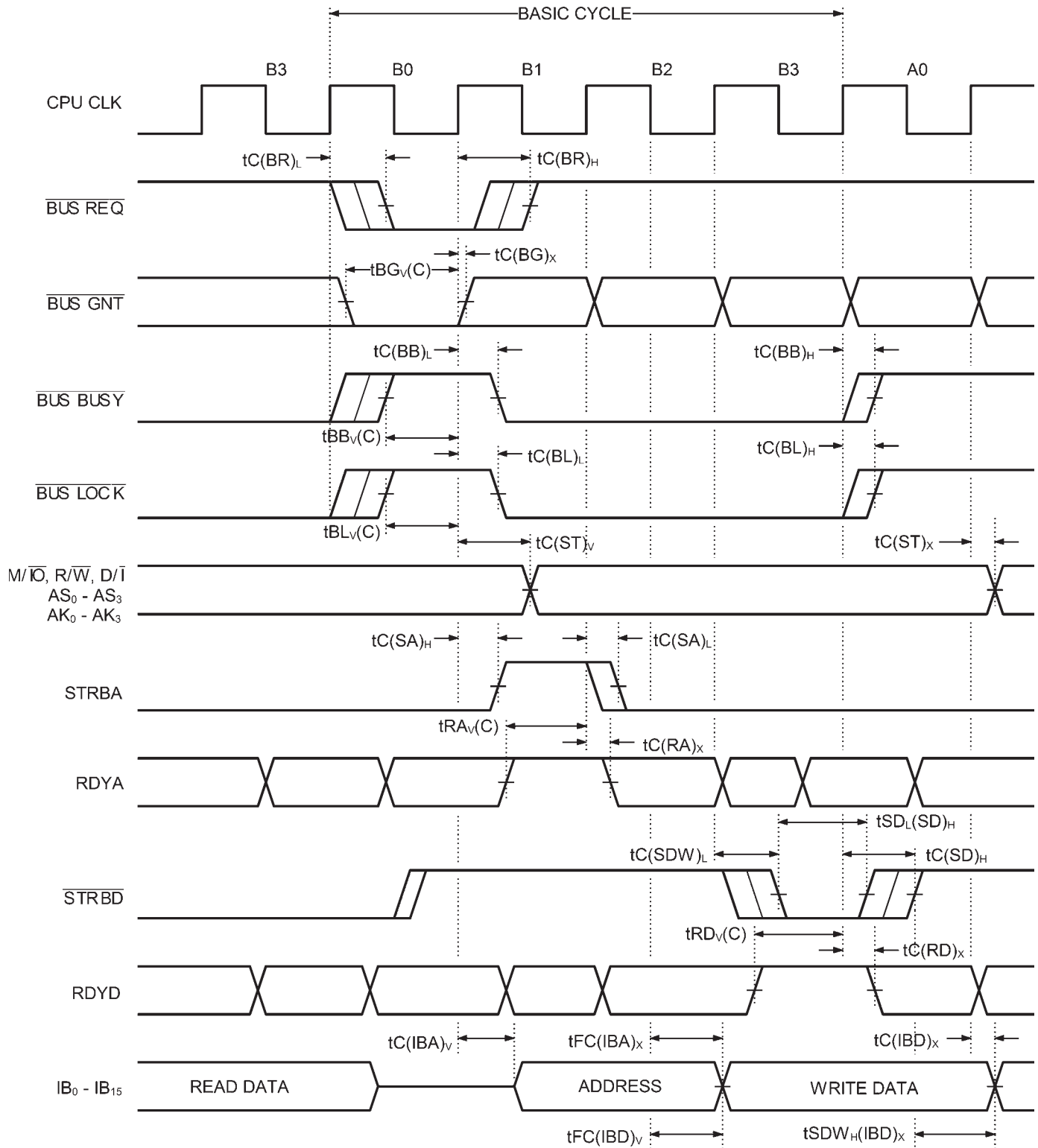

Note:
All time measurements on active signals relate to the 1.5 volt level.

MINIMUM READ BUS CYCLE TIMING DIAGRAM

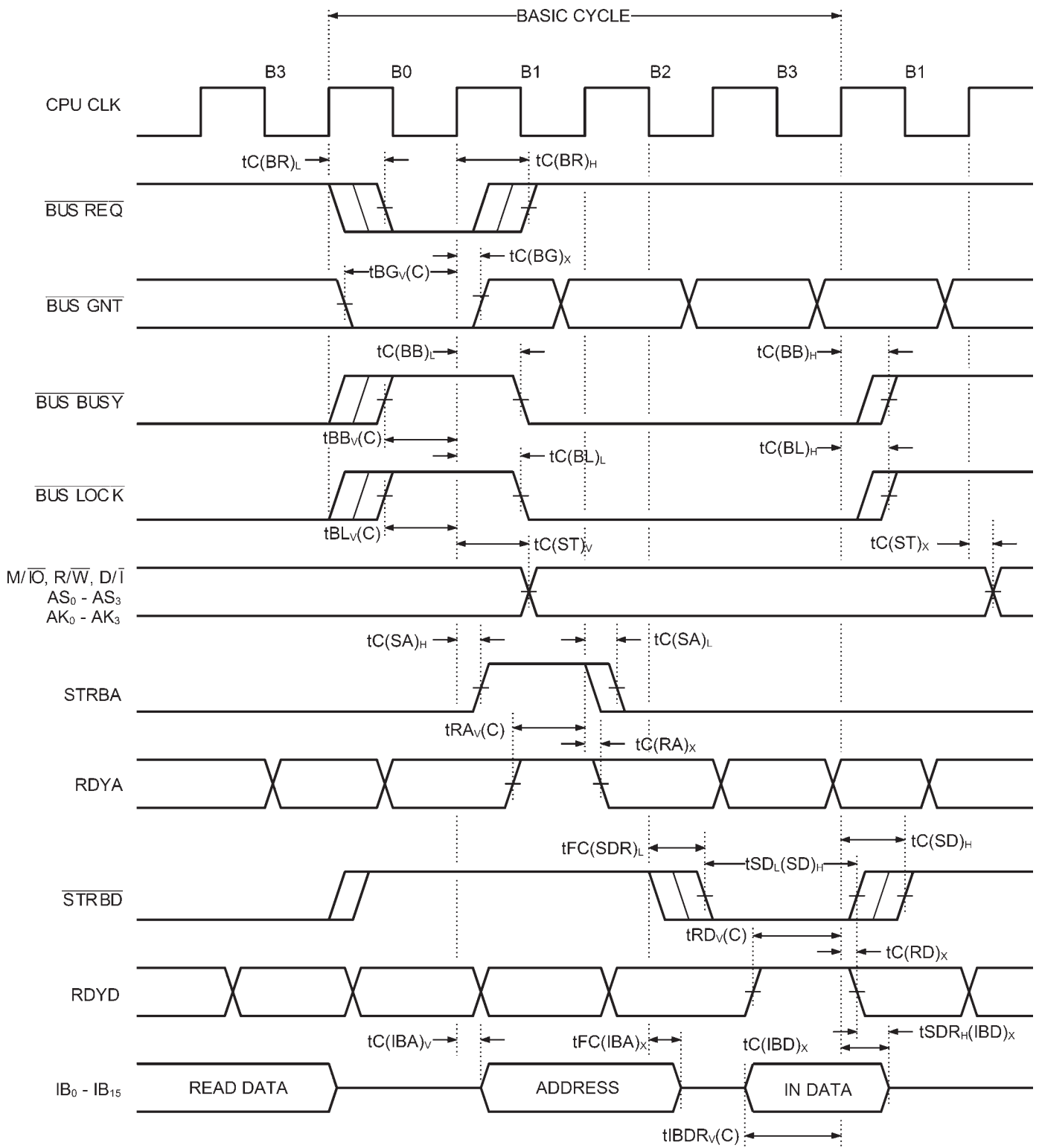

Note:
All time measurements on active signals relate to the 1.5 volt level.

MINIMUM WRITE BUS CYCLE, FOLLOWED BY A NON-BUS CYCLE, TIMING DIAGRAM

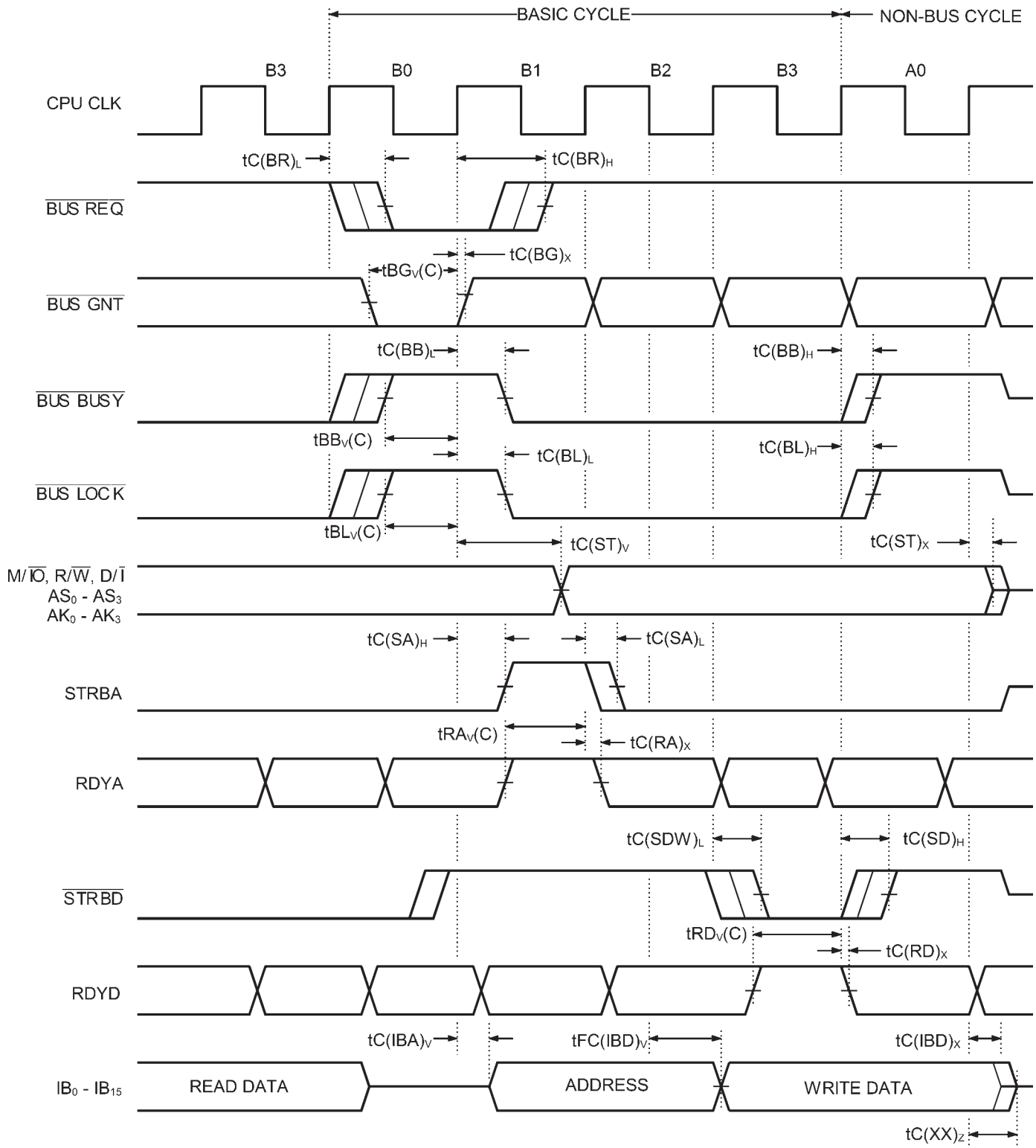

Note:
All time measurements on active signals relate to the 1.5 volt level.

TRIGO RST DISCRETE TIMING DIAGRAM

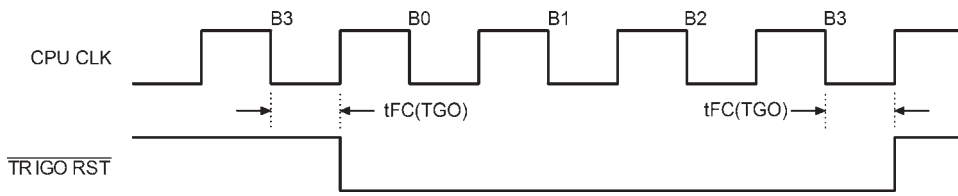

DMA EN DISCRETE TIMING DIAGRAM

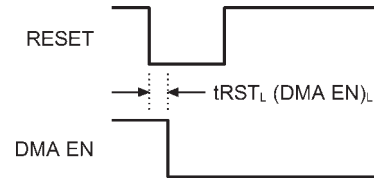

NORMAL POWER UP DISCRETE TIMING DIAGRAM

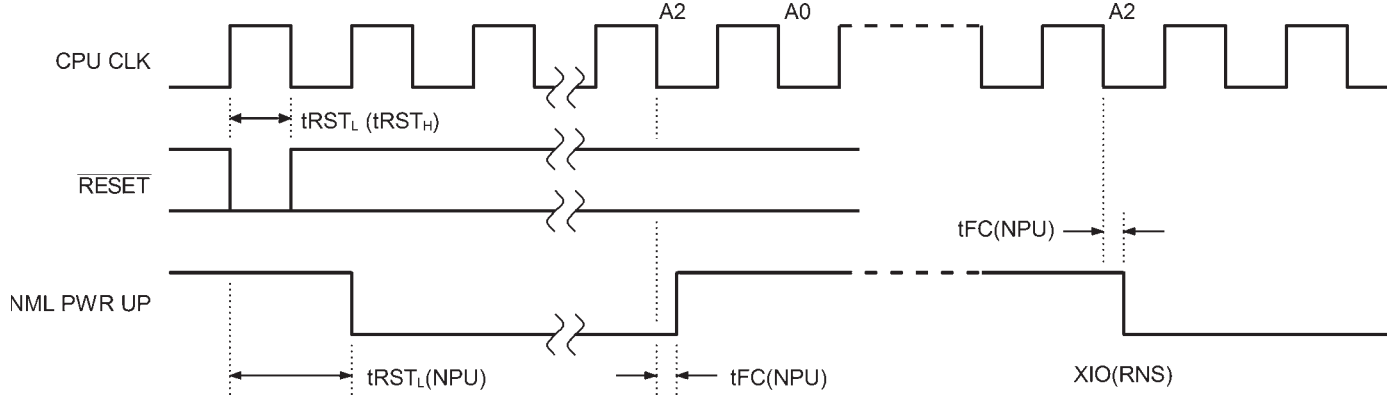

XIO OPERATIONS

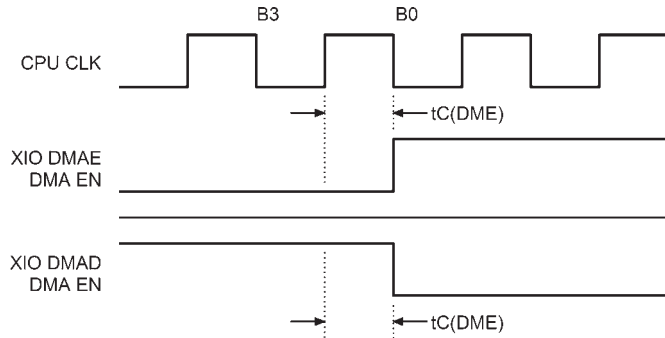

SNEW DISCRETE TIMING DIAGRAM

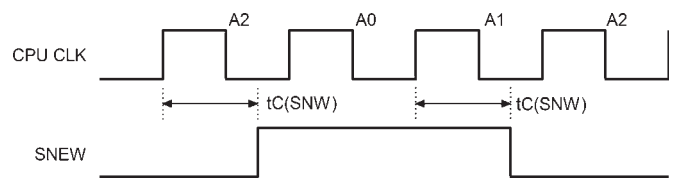

Note:

All time measurements on active signals relate to the 1.5 volt level.

EXTERNAL FAULTS AND INTERRUPTS TIMING DIAGRAM

Edge-sensitive interrupts and faults (SYSFLT₀, SYSFLT₁) min. pulse width

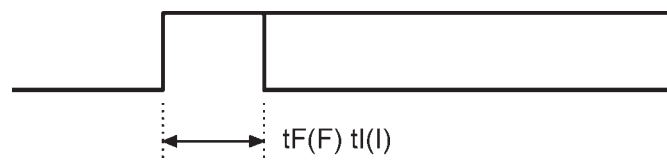

Level-sensitive interrupts

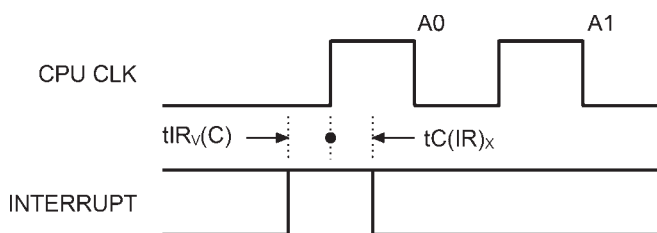

Note:
 $tC(IR)_x$ max = 35 clocks

Level-sensitive faults

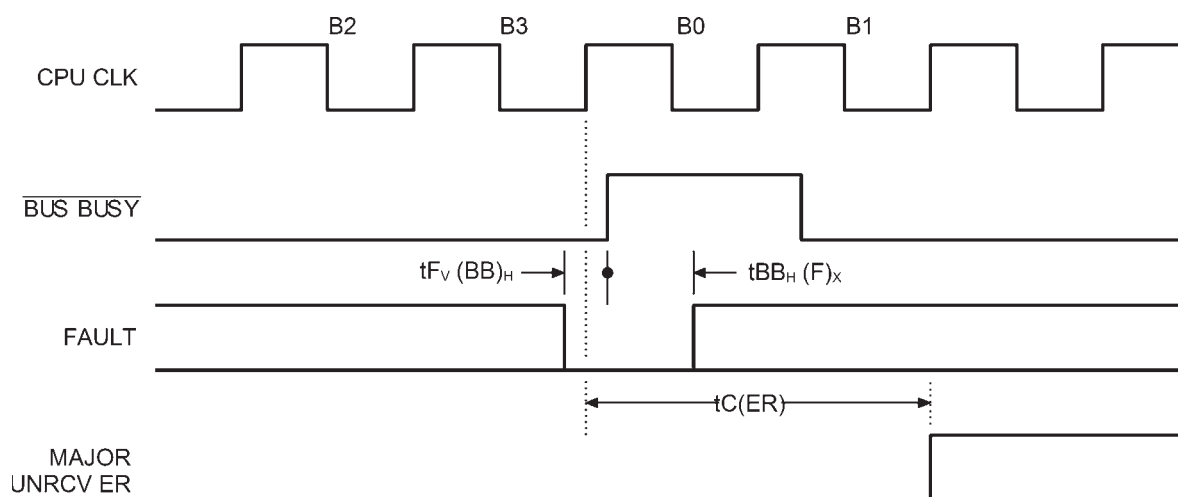

CON REQ

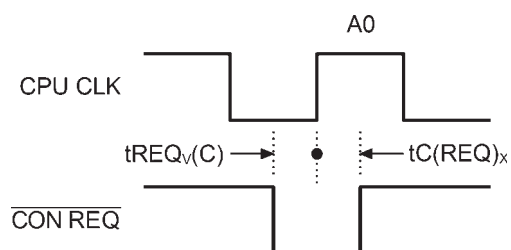

Note:
 All time measurements on active signals relate to the 1.5 volt level.

BUS ACQUISITION

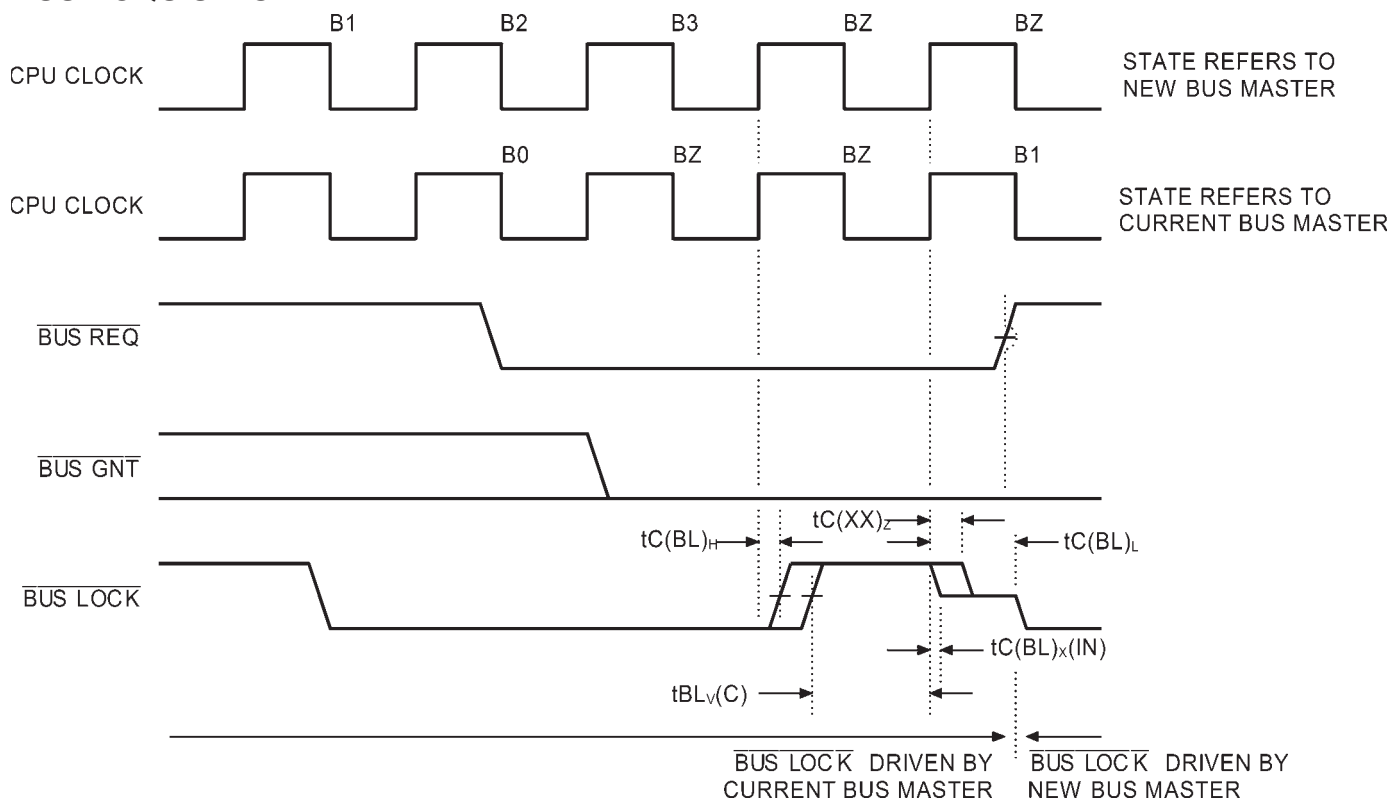

Note:

A CPU contending for the BUS will assert the $\overline{BUS REQ}$ line, and will acquire it when $\overline{BUS GNT}$ is asserted and the BUS is not locked ($\overline{BUS LOCK}$ is high).

SWITCHING TIME TEST CIRCUITS

Standard Output (Non-Three-State)

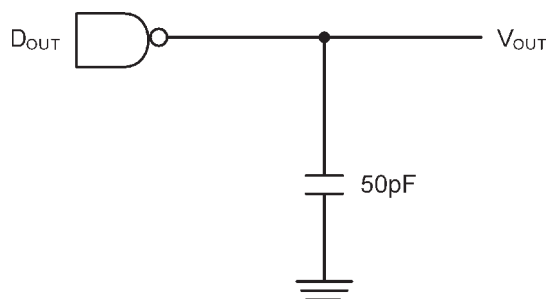

Three-State

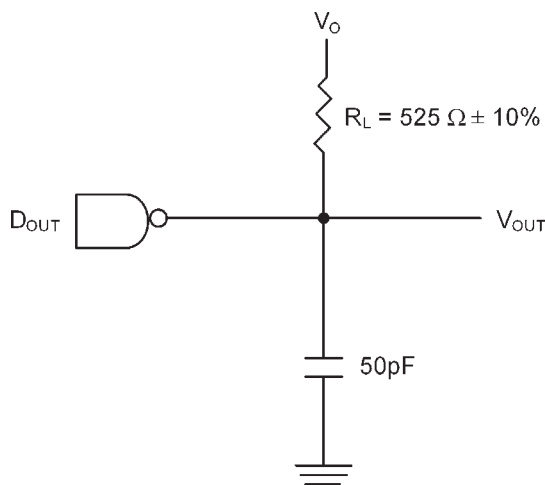

Note:

All time measurements on active signals relate to the 1.5 volt level.

Parameter	V0	VMEA
t_{PLZ}	$\geq 3V$	0.5V
t_{PHZ}	0V	$V_{CC} - 0.5V$
t_{PXL}	$V_{CC}/2$	1.5V
t_{PXH}	$V_{CC}/2$	1.5V

SIGNAL DESCRIPTIONS

CLOCKS AND EXTERNAL REQUESTS

Mnemonic	Name	Description
CPU CLK	CPU clock	A single phase input clock signal (0-40 MHz, 40 percent to 60 percent duty cycle).
TIMER CLK	Timer clock	A 100 KHz input that, after synchronization with CPU CLK, provides the clock for timer A and timer B. If timers are used, the CPU CLK signal frequency must be > 300 KHz.
$\overline{\text{RESET}}$	Reset	An active LOW input that initializes the device.
$\overline{\text{CON REQ}}$	Console request	An active LOW input that initiates console operations after completion of the current instruction.

INTERRUPT INPUTS

Mnemonic	Name	Description
PWRDN INT	Power down interrupt	An interrupt request input that cannot be masked or disabled. This signal is active on the positive going edge or the high level, according to the interrupt mode bit in the configuration register.
USR ₀ INT - USR ₅ INT	User interrupt	Interrupt request input signals that are active on the positive going edge or the high level, according to the interrupt mode bit in the configuration register.
IOL ₁ INT - IOL ₂ INT	I/O level interrupts	Active HIGH interrupt request inputs that can be used to expand the number of user interrupts.

FAULTS

Mnemonic	Name	Description
$\overline{\text{MEM PRT ER}}$	Memory protect error	An active LOW input generated by the MMU or BPU, or both and sampled by the $\overline{\text{BUS BUSY}}$ signal into the Fault Register (bit 0 CPU bus cycle, bit 1 if non-CPU bus cycle).
$\overline{\text{MEM PAR ER}}$	Memory parity error	An active LOW input sampled by the $\overline{\text{BUS BUSY}}$ signal into bit 2 of the fault register.
$\overline{\text{EXT ADR ER}}$	External address error	An active LOW input sampled by the $\overline{\text{BUS BUSY}}$ signal into the Fault register (bit 5 or 8), depending on the cycle (memory or I/O).
SYSFLT ₀ SYSFLT ₁	System fault ₀ , System fault ₁ ,	Asynchronous, positive edge-sensitive inputs that set bit 7 (SYSFLT ₀) or bits 13 and 15 (SYSFLT ₁) in the Fault register.

ERROR CONTROL

Mnemonic	Name	Description
UNRCV ER	Unrecoverable error	An active HIGH output that indicates the occurrence of an error classified as unrecoverable.
MAJ ER	Major error	An active HIGH output that indicates the occurrence of an error classified as major.

SIGNAL DESCRIPTIONS (Continued)**BUS CONTROL**

Mnemonic	Name	Description
D/ \bar{I}	Data or instruction	An output signal that indicates whether the current bus cycle access is for Data (HIGH) or Instruction (LOW). It is three-state during bus cycles not assigned to the CPU. This line can be used as an additional memory address bit for systems that require separate data and program memory.
R/ \bar{W}	Read or write	An output signal that indicates direction of data flow with respect to the current bus master. A HIGH indicates a read or input operation and a LOW indicates a write or output operation. The signal is three-state during bus cycles not assigned to the CPU.
M/ $\bar{I/O}$	Memory or I/O	An output signal that indicates whether the current bus cycle is memory (HIGH) or I/O (LOW). This signal is three-state during bus cycles not assigned to the CPU.
STRBA	Address strobe	An active HIGH output that can be used to externally latch the memory or I/O address at the HIGH-to-LOW transition of the strobe. The signal is three-state during bus cycles not assigned to the CPU.
RDYA	Address ready	An active HIGH input that can be used to extend the address phase of a bus cycle. When RDYA is not active, wait states are inserted by the device to accommodate slower memory or I/O devices.
$\overline{\text{STRBD}}$	Data strobe	An active LOW output that can be used to strobe data in memory and XIO cycles. This signal is three-state during bus cycles not assigned to the CPU.
RDYD	Data ready	An active HIGH input that extends the data phase of a bus cycle. When RDYD is not active, wait states are inserted by the device to accommodate slower memory or I/O devices.

INFORMATION BUS

Mnemonic	Name	Description
IB ₀ - IB ₁₅	Information bus	A bidirectional time-multiplexed address/data bus that is three-state during bus cycles not assigned to the CPU. IB ₀ is the most significant bit.

STATUS BUS

Mnemonic	Name	Description
AK ₀ - AK ₃	Access key	Outputs used to match the access lock in the MMU for memory accesses (a mismatch will cause the MMU to pull the MEM PRT ER signal LOW), and also indicates processor state (PS). Privileged instructions can be executed with PS = 0 only. These signals are three-state during bus cycles not assigned to the CPU.
AS ₀ - AS ₃	Address state	Outputs that select the page register group in the MMU. It is three-state during bus cycles not assigned to the CPU. [These outputs together with D/ \bar{I} can be used to expand the device direct addressing space to 4 MBytes, in a nonprotected mode (no MMU)]. However, using this addressing mode may produce situations not specified in MIL-STD-1750.

SIGNAL DESCRIPTIONS (Continued)

BUS ARBITRATION

Mnemonic	Name	Description
$\overline{\text{BUS REQ}}$	Bus request	An active LOW output that indicates the CPU requires the bus. It becomes inactive when the CPU has acquired the bus and started the bus cycle.
$\overline{\text{BUS GNT}}$	Bus grant	An active LOW input from an external arbiter that indicates the CPU currently has the highest priority bus request. If the bus is not used and not locked, the CPU may begin a bus cycle, commencing with the next CPU clock. A HIGH level will hold the CPU in Hi-Z state (Bz), three-stating the IB bus status lines ($\overline{\text{D/I}}$, $\overline{\text{R/W}}$, $\overline{\text{M/I\O}}$), strobes ($\overline{\text{STRBA}}$, $\overline{\text{STRBD}}$), and all the other lines that go three-state when this CPU does not have the bus.
$\overline{\text{BUS BUSY}}$	Bus busy	An active LOW, bidirectional signal used to establish the beginning and end of a bus cycle. The trailing edge (LOW-to-HIGH transition) is used for sampling bits into the fault register. It is three-state in bus cycles not assigned to this CPU. However, the CPU monitors the $\overline{\text{BUS BUSY}}$ line for latching non-CPU bus cycle faults into the fault register.
$\overline{\text{BUS LOCK}}$	Bus lock	An active low, bi-directional signal used to lock the bus for successive bus cycles. During non-locked bus cycles, the $\overline{\text{BUS LOCK}}$ signal mimics the $\overline{\text{BUS BUSY}}$ signal. It is three-state during bus cycles not assigned to the CPU. The following instructions will lock the bus: INCM, DECM, SB, RB, TSB, SRM, STUB and STL B.

DISCRETE CONTROL

Mnemonic	Name	Description
DMA EN	Direct memory Access enable	An active HIGH output that indicates the DMA is enabled. It is disabled when the CPU is initialized (reset) and can be enabled or disabled under program control (I/O commands DMAE, DMAD).
NML PWRUP	Normal power up	An active HIGH output that is set when the CPU has successfully completed the built-in self test in the initialization sequence. It can be reset by the I/O command RNS.
SNEW	Start new	An active HIGH output that indicates a new instruction is about to start executing in the next cycle.
$\overline{\text{TRIGO RST}}$	Trigger-go reset	An active LOW discrete output. This signal can be pulsed low under program control I/O address 400B (Hex) and is automatically pulsed during processor initialization.

TERMINAL CONNECTIONS

Case Outlines: 1) Leaded Chip Carrier with unformed leads and 2) Leaded Chip Carrier with Gull-Wing Leads					
Terminal Number	Terminal Symbol	Terminal Number	Terminal Symbol	Terminal Number	Terminal Symbol
1	GND	23	IB ₁₁	46	AS ₂
2	$\overline{\text{CON REQ}}$	24	IB ₁₂	47	AS ₁
3	DMA EN	25	IB ₁₃	48	AS ₀
4	$\overline{\text{TRIGORST}}$	26	IB ₁₄	49	GND
5	$\overline{\text{RESET}}$	27	IB ₁₅	50	AK ₃
6	NML PWRUP	28	$\overline{\text{MEM PRTER}}$	51	AK ₂
7	TIMER CLK	29	$\overline{\text{MEM PARER}}$	52	VCC
8	UNRCV ER	30	$\overline{\text{EXT ADRER}}$	53	AK ₁
9	GND	31	SYSFLT ₀	54	AK ₀
10	IB ₀	32	SYSFLT ₁	55	CPU CLK
11	IB ₁	33	MAJ ER	56	STRBA
12	IB ₂	34	GND	57	$\overline{\text{STRBD}}$
13	IB ₃	35	VCC	58	$\overline{\text{BUS REQ}}$
14	IB ₄	36	PWRDN INT	59	RDYA
15	IB ₅	37	USR ₀ INT	60	RDYD
16	IB ₆	38	USR ₁ INT	61	R/ $\overline{\text{W}}$
17	IB ₇	39	USR ₂ INT	62	D/ $\overline{\text{I}}$
18	GND	40	USR ₃ INT	63	M/ $\overline{\text{IO}}$
19	IB ₈	41	USR ₄ INT	64	$\overline{\text{BUS BUSY}}$
20	IB ₉	42	USR ₅ INT	65	$\overline{\text{BUS GNT}}$
21	VCC	43	IOL ₁ INT	66	$\overline{\text{BUS LOCK}}$
22	IB ₁₀	44	IOL ₂ INT	67	SNEW
		45	AS ₃	68	VCC

ORDERING INFORMATION

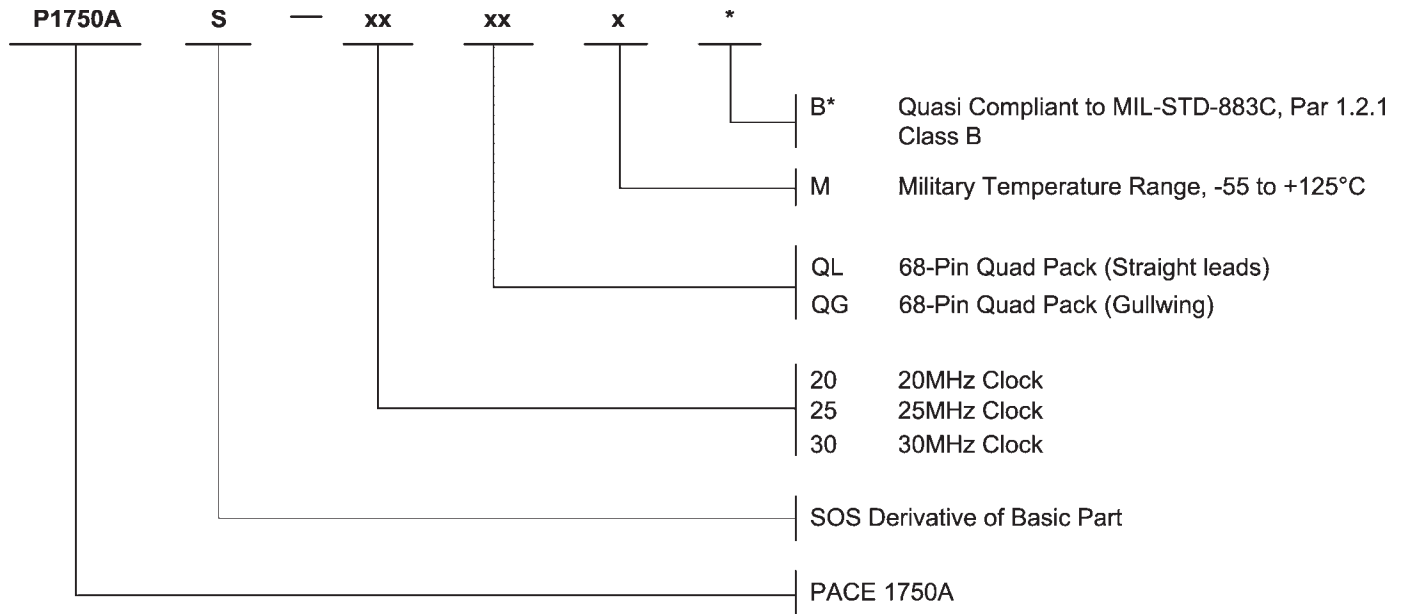

CASE OUTLINE 1:

68 Lead Quad Pack with Straight Leads (Ordering Code QL)

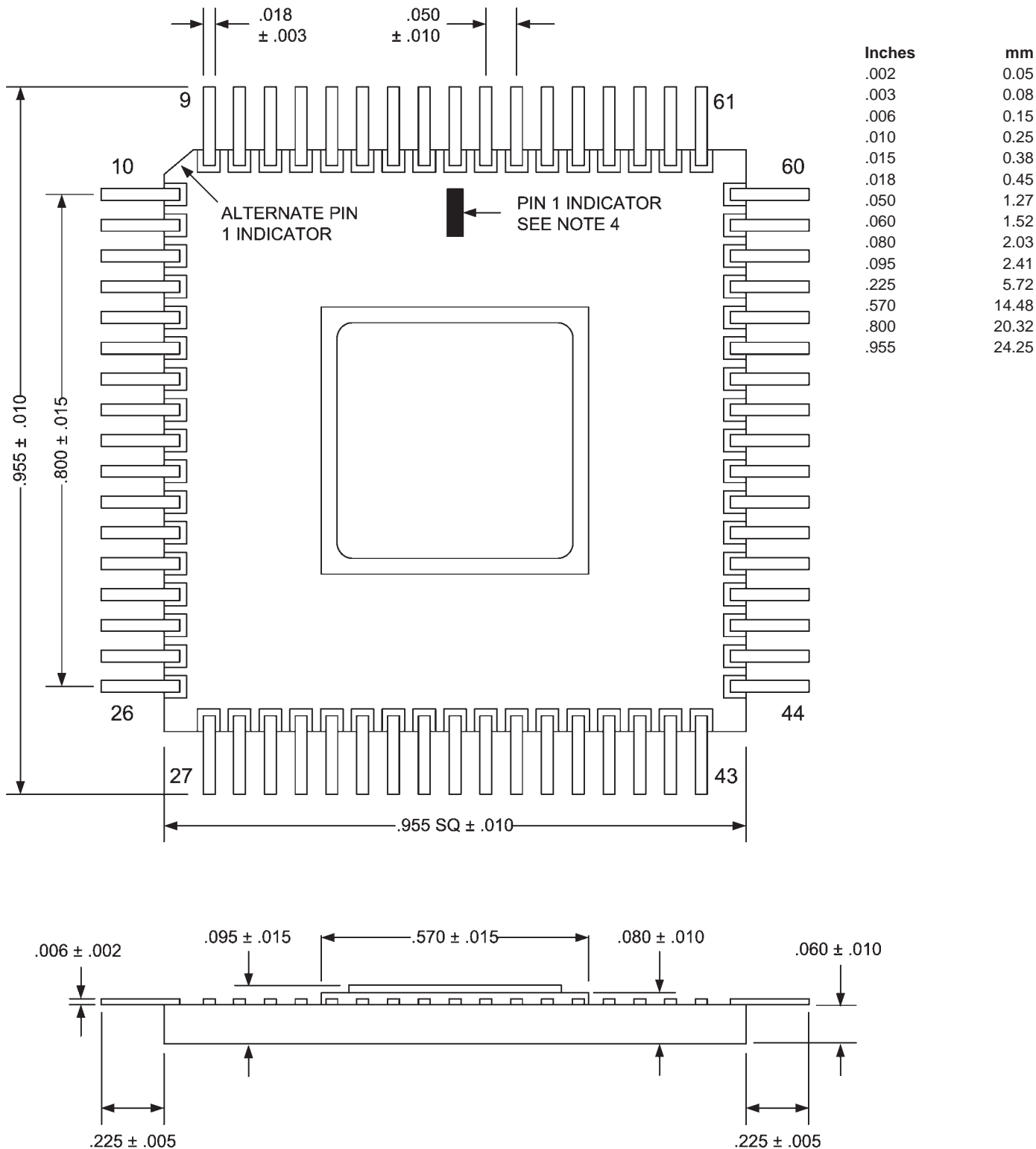

NOTES:

- 1) Dimensions are in inches.
- 2) Metric equivalents are given for general information only.
- 3) Unless otherwise specified, tolerances are .02 (0.5 mm) for two place decimals and .005 (0.13 mm) for three place decimals.
- 4) Pin 1 indicator can be either rectangle, dot, or triangle at specified location or referenced to the uniquely beveled corner.
- 5) Corners indicated as notched may be either notched or square.

CASE OUTLINE 2:

68 Lead Quad Pack with Gullwing Leads (Ordering Code QG)

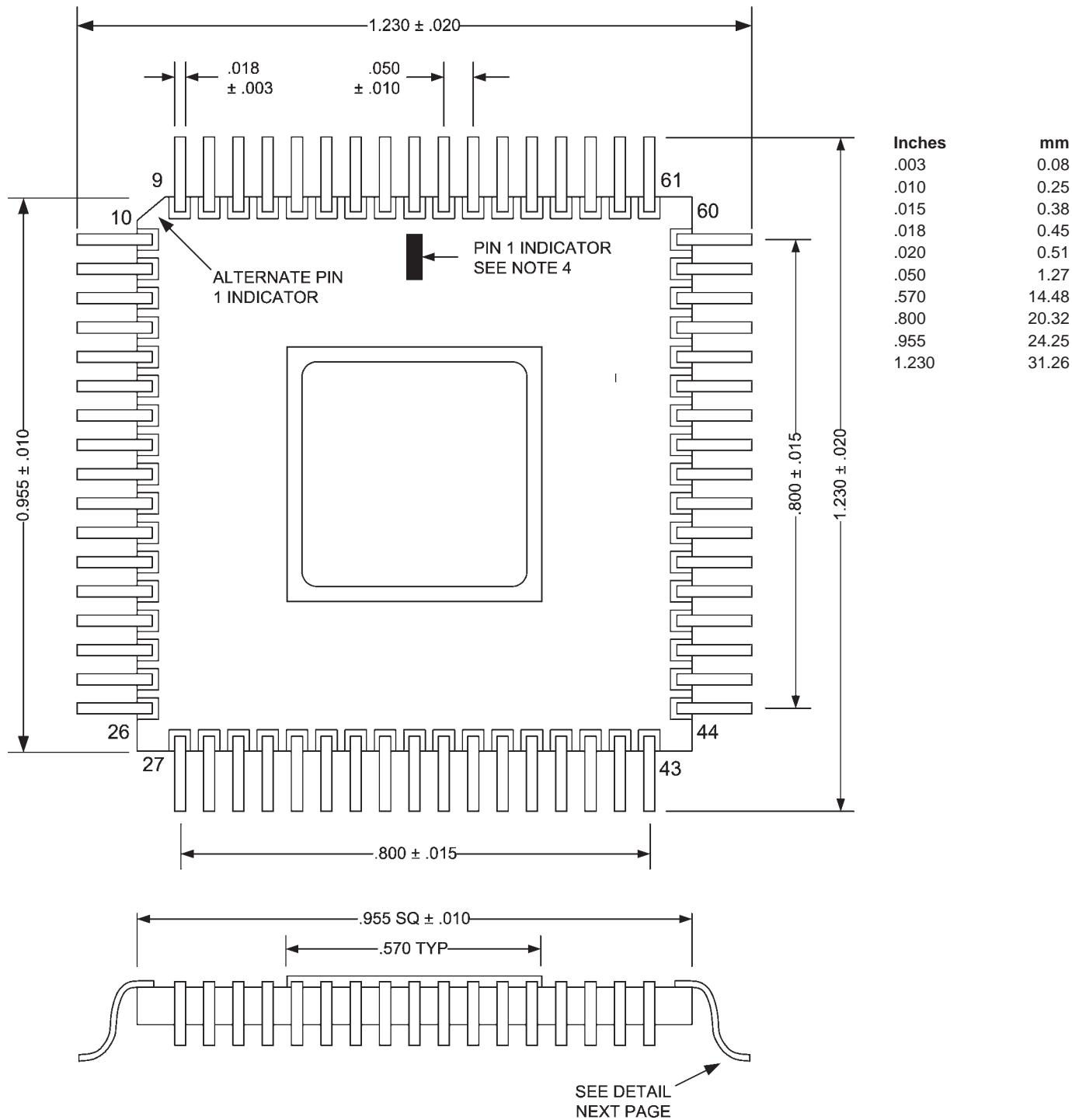

NOTES:

- 1) Dimensions are in inches.
- 2) Metric equivalents are given for general information only.
- 3) Unless otherwise specified, tolerances are .02 (0.5 mm) for two place decimals and .005 (0.13 mm) for three place decimals.
- 4) Pin 1 indicator can either be rectangle, dot, or triangle at specified location or referenced to the uniquely beveled corner.
- 5) Corners indicated as notched may be either notched or square (with radius).
- 6) Case 2 is derived from Case 1 by forming the leads to the shown gullwing configuration.

LEAD FORM DETAIL

Symbol	INCHES	
	Min	Max
A	0.048	0.090
A1	0.011	0.031
B	0.016	0.021
C	0.004	0.008
e1	0.050 BSC	
D	1.210	1.250
D1	0.945	0.965
D2	0.800 BSC	
E	1.210	1.250
E1	0.945	0.965
E2	0.800 BSC	
L*	0.270 Nominal	
L0	0.120	0.210
L3	0.040	0.050
L4	0.086	0.109
R1	0.018	0.020
R2	0.018	0.020
Φ_1	4°	8°
Φ_2	-1°	7°
A0**		0.141

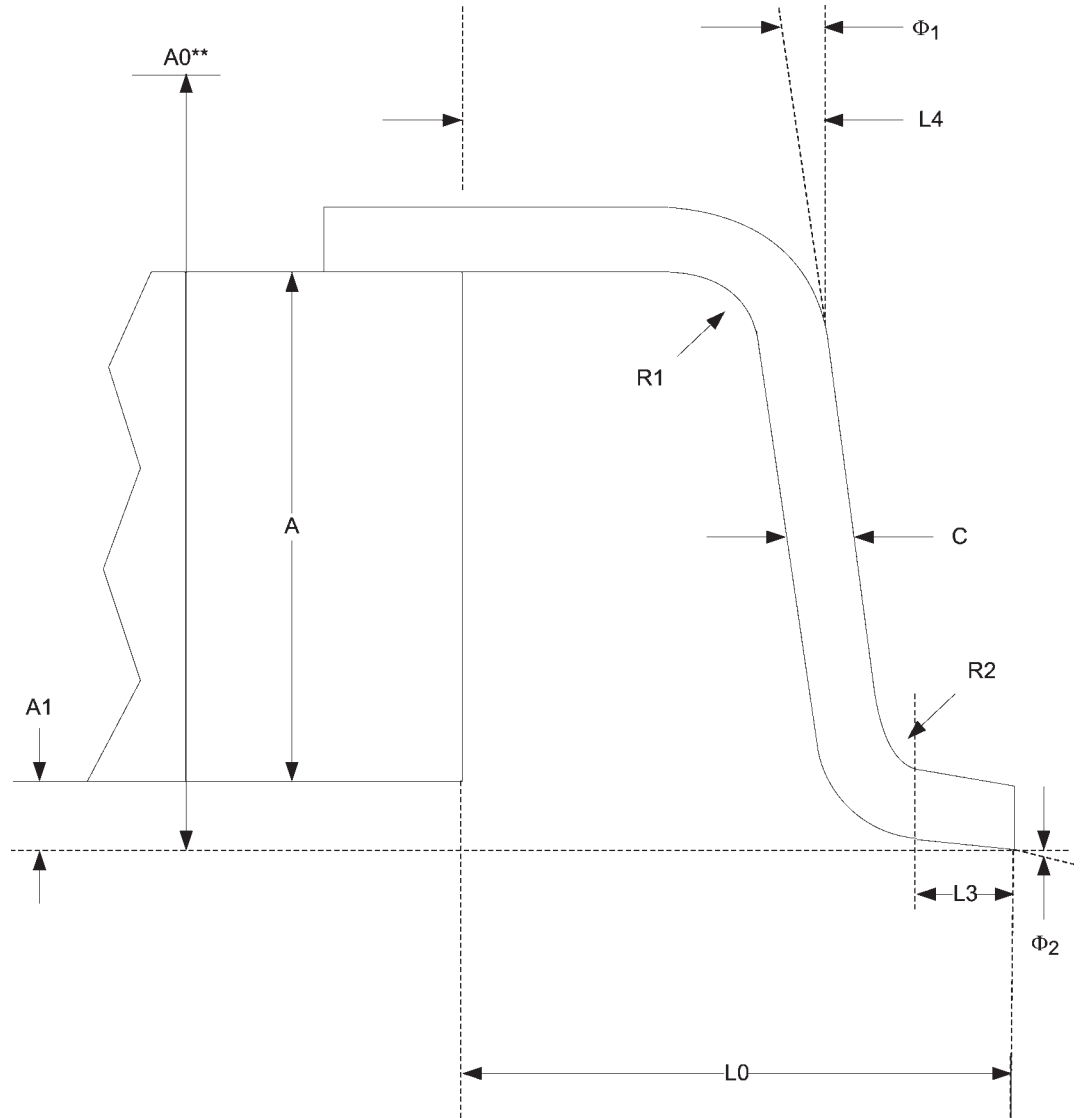

* Lead length in the straight lead configuration, prior to leadforming (used for all test and in-process WIP operations).

** Measured from the highest of the top of the leads or the top of the lid.

REVISIONS

DOCUMENT NUMBER:		MICRO-6	
DOCUMENT TITLE:		PACE1750A CMOS/SOS 16-BIT PROCESSOR	
REV.	ISSUE DATE	ORIG. OF CHANGE	DESCRIPTION OF CHANGE
ORIG	May-89	RKK	New Data Sheet
A	Jul-04	JDB	Added Pyramid logo
B	Aug-05	JDB	Re-created electronic version