

Features

- Fast Read Access Time - 70 ns
- Low Power CMOS Operation
 - 100 μ A max. Standby
 - 20 mA max. Active at 5 MHz
- Wide Selection of JEDEC Standard Packages Including:
 - 28-Lead 600-mil Cerdip, OTP Plastic DIP, SOIC, or TSOP
 - 32-Pad LCC, 32-Lead JLCC and OTP PLCC
- 5V \pm 10% Supply
- High Reliability CMOS Technology
 - 2000 V ESD Protection
 - 200 mA Latchup Immunity
- Rapid Programming - 100 μ s/byte (typical)
- Two-line Control
- CMOS and TTL Compatible Inputs and Outputs
- Integrated Product Identification Code
- Military, Commercial and Industrial Temperature Ranges

256K (32K x 8)
UV
Erasable
CMOS
EPROM

4

Description

The AT27C256R chip is a low-power, high performance 262,144 bit Ultraviolet Erasable and Electrically Programmable Read Only Memory (EPROM) organized 32K x 8. It requires only one 5 V power supply in normal read mode operation. Any byte can be accessed in less than 70 ns, eliminating the need for speed reducing WAIT states on high performance micro-processor systems.

Atmel's scaled CMOS technology provides low active power consumption, and fast programming. Power consumption is typically only 8 mA in Active Mode and less than 10 μ A in Standby.

Pin Configurations

| Pin Name | Function |
|----------|---------------|
| A0-A14 | Addresses |
| O0-O7 | Outputs |
| CE | Chip Enable |
| OE | Output Enable |
| NC | No Connect |

CDIP, PDIP, SOIC Top

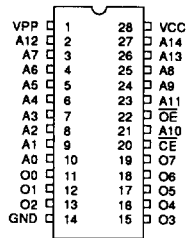

LCC, JLCC, PLCC Top

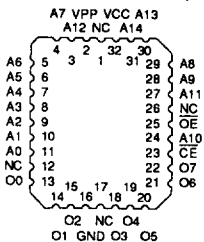

TSOP Top View

Type 1



Note: PLCC Package Pins 1 and 17 are DON'T CONNECT.





Description (Continued)

The AT27C256R comes in a choice of industry standard JEDEC-approved packages including: 28-pin windowed ceramic DIP, 28-pin one time programmable (OTP) plastic DIP, 28-pin OTP gull wing small outline IC (SOIC), 28-pin OTP thin small outline package (TSOP), 32-pad windowed ceramic leadless chip carrier (LCC), 32-lead windowed J-leaded chip carrier (JLCC), and 32-lead OTP plastic J-leaded chip carrier (PLCC). All devices feature two line control (\overline{CE} , \overline{OE}) to give designers the flexibility to prevent bus contention.

With high density 32K byte storage capability, the AT27C256R allows firmware to be stored reliably and to be accessed by the system without the delays of mass storage media.

Atmel's 27C256R has additional features to ensure high quality and efficient production use. The Rapid Programming Algorithm reduces the time required to program the part and guarantees reliable programming. Programming time is typically only 100 μ s/byte. The Integrated Product Identification Code electronically identifies the device and manufacturer. This feature is used by industry standard programming equipment to select the proper programming algorithms and voltages.

Erase Characteristics

The entire memory array of the AT27C256R is erased (all outputs read as V_{OH}) after exposure to ultraviolet light at a wavelength of 2537Å. Complete erasure is assured after a minimum of 20 minutes exposure using 12,000 μ W/cm² intensity lamps spaced one inch away from the chip. Minimum erase time for lamps at other intensity ratings can be calculated from the minimum integrated erasure dose of 15 W-sec/cm². To prevent unintentional erasure, an opaque label is recommended to cover the clear window on any UV erasable EPROM which will be subjected to continuous fluorescent indoor lighting or sunlight.

Operating Modes

| Mode \ Pin | \overline{CE} | \overline{OE} | Ai | V _{PP} | V _{CC} | Outputs |
|---------------------------------------|-----------------|-----------------|--|-----------------|-----------------|---------------------|
| Read | V _{IL} | V _{IL} | Ai | V _{CC} | V _{CC} | DOUT |
| Output Disable | V _{IL} | V _{IH} | X ⁽¹⁾ | V _{CC} | V _{CC} | High Z |
| Standby | V _{IH} | X | X | V _{CC} | V _{CC} | High Z |
| Rapid Program ⁽²⁾ | V _{IL} | V _{IH} | Ai | V _{PP} | V _{CC} | DIN |
| PGM Verify ⁽²⁾ | X | V _{IL} | Ai | V _{PP} | V _{CC} | DOUT |
| Optional PGM Verify ⁽²⁾ | V _{IL} | V _{IL} | Ai | V _{CC} | V _{CC} | DOUT |
| PGM Inhibit ⁽²⁾ | V _{IH} | V _{IH} | X | V _{PP} | V _{CC} | High Z |
| Product Identification ⁽⁴⁾ | V _{IL} | V _{IL} | A9=V _{IH} ⁽³⁾ A0=V _{IH} or V _{IL} A1-A14=V _{IL} | V _{CC} | V _{CC} | Identification Code |

Notes: 1. X can be V_{IL} or V_{IH}.
2. Refer to Programming characteristics.
3. V_{IH} = 12.0 \pm 0.5 V.

Block Diagram

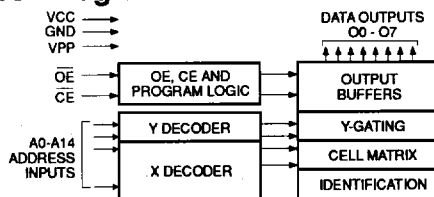

Absolute Maximum Ratings*

| | |
|--|----------------------------------|
| Temperature Under Bias | -55°C to +125°C |
| Storage Temperature | -65°C to +150°C |
| Voltage on Any Pin with Respect to Ground | -2.0 V to +7.0 V ⁽¹⁾ |
| Voltage on A9 with Respect to Ground | -2.0 V to +14.0 V ⁽¹⁾ |
| V _{PP} Supply Voltage with Respect to Ground | -2.0 V to +14.0 V ⁽¹⁾ |
| Integrated UV Erase Dose | 7258 W-sec/cm ² |

*NOTICE: Stresses beyond those listed under "Absolute Maximum Ratings" may cause permanent damage to the device. This is a stress rating only and functional operation of the device at these or any other conditions beyond those indicated in the operational sections of this specification is not implied. Exposure to absolute maximum rating conditions for extended periods may affect device reliability.

Notes:

1. Minimum voltage is -0.6 V dc which may undershoot to -2.0 V for pulses of less than 20 ns. Maximum output pin voltage is V_{CC}+0.75 V dc which may overshoot to +7.0 V for pulses of less than 20 ns.

D.C. and A.C. Operating Conditions for Read Operation

| | | AT27C256R | | | | | |
|------------------------------|------|--------------|---------------|---------------|---------------|---------------|---------------|
| | | -70 | -90 | -12 | -15 | -20 | -25 |
| Operating Temperature (Case) | Com. | 0°C - 70°C | 0°C - 70°C | 0°C - 70°C | 0°C - 70°C | 0°C - 70°C | 0°C - 70°C |
| | Ind. | -40°C - 85°C | -40°C - 85°C | -40°C - 85°C | -40°C - 85°C | -40°C - 85°C | -40°C - 85°C |
| | Mil. | | -55°C - 125°C | -55°C - 125°C | -55°C - 125°C | -55°C - 125°C | -55°C - 125°C |
| V _{CC} Power Supply | | 5 V ± 10% | 5 V ± 10% | 5 V ± 10% | 5 V ± 10% | 5 V ± 10% | 5 V ± 10% |

D.C. and Operating Characteristics for Read Operation

4

| Symbol | Parameter | Condition | Min | Max | Units |
|---------------------------------|---|--|-----------|-----------------------|-------|
| I _{LI} | Input Load Current | V _{IN} = -0.1 V to V _{CC} +1 V | | 10 | μA |
| I _{LO} | Output Leakage Current | V _{OUT} = -0.1 V to V _{CC} +0.1 V | | 10 | μA |
| I _{PP1} ⁽²⁾ | V _{PP} ⁽¹⁾ Read/Standby Current | V _{PP} = 3.8 to V _{CC} +0.3 V | | 10 | μA |
| I _{SB} | V _{CC} ⁽¹⁾ Standby Current | I _{SB1} (CMOS) | Com. | 100 | μA |
| | | CE = V _{CC} -0.3 to V _{CC} +1.0 V | Ind.,Mil. | 200 | μA |
| | | I _{SB2} (TTL) | Com. | 2 | mA |
| | | CE = 2.0 to V _{CC} +1.0 V | Ind.,Mil. | 3 | mA |
| I _{CC} | V _{CC} Active Current | f = 5 MHz, I _{OUT} = 0 mA, CE = V _{IL} | Com. | 20 | mA |
| | | | Ind.,Mil. | 25 | mA |
| V _{IL} | Input Low Voltage | | -0.6 | 0.8 | V |
| V _{IH} | Input High Voltage | | 2.0 | V _{CC} +0.75 | V |
| V _{OL} | Output Low Voltage | I _{OL} = 2.1 mA | | .45 | V |
| V _{OH} | Output High Voltage | I _{OH} = -100 μA | | V _{CC} -0.3 | V |
| | | I _{OH} = -2.5 mA | | 3.5 | V |
| | | I _{OH} = -400 μA | | 2.4 | V |
| V _{PP} | V _{PP} Read Voltage | V _{CC} = 5 ± 0.25 V | 3.8 | V _{CC} +3 | V |

Notes: 1. V_{CC} must be applied simultaneously or before V_{PP}, and removed simultaneously or after V_{PP}.

2. V_{PP} may be connected directly to V_{CC}, except during programming. The supply current would then be the sum of I_{CC} and I_{PP}.

A.C. Characteristics for Read Operation

| | | | AT27C256R | | | | | | Units | | | | | |
|----------------------------------|--|--|-----------|-----|-----|-----|-----|-----|-------|-----|-----|-----|-----|-----|
| | | | -70 | | -90 | | -12 | | | -15 | | -20 | | -25 |
| Symbol | Parameter | Condition | Min | Max | Min | Max | Min | Max | Min | Max | Min | Max | Min | Max |
| t _{ACC} ⁽⁴⁾ | Address to Output Delay | CE = OE = V _{IL} Com., Ind. Mil. | 70 | 90 | 120 | 150 | 200 | 250 | ns | | | | | |
| | | | | 90 | 120 | 150 | 200 | 250 | ns | | | | | |
| t _{CE} ⁽³⁾ | CE to Output Delay | OE = V _{IL} | 70 | 90 | 120 | 150 | 200 | 250 | ns | | | | | |
| t _{OE} ^(3,4) | OE to Output Delay | CE = V _{IL} | 30 | 35 | 35 | 60 | 75 | 100 | ns | | | | | |
| t _{DF} ^(2,5) | OE or CE High to Output Float | CE = V _{IL} | 25 | 30 | 30 | 45 | 55 | 60 | ns | | | | | |
| t _{OH} | Output Hold from Address, CE or OE, whichever occurred first | CE = OE = V _{IL} | 0 | 0 | 0 | 0 | 0 | 0 | 0 | ns | | | | |

Notes: 2, 3, 4, 5. - see AC Waveforms for Read Operation.

A.C. Waveforms for Read Operation ⁽¹⁾

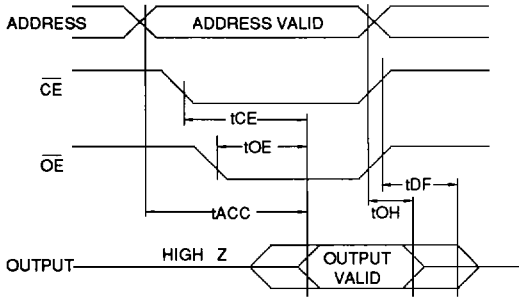

Notes:

1. Timing measurement references are 0.8 V and 2.0 V. Input AC driving levels are 0.45 V and 2.4 V, unless otherwise specified.
2. t_{DF} is specified from \overline{OE} or \overline{CE} , whichever occurs first. Output float is defined as the point when data is no longer driven.
3. \overline{OE} may be delayed up to t_{CE-tOE} after the falling edge of \overline{CE} without impact on t_{CE} .
4. \overline{OE} may be delayed up to $t_{ACC-tOE}$ after the address is valid without impact on t_{ACC} .
5. This parameter is only sampled and is not 100% tested.

Input Test Waveforms and Measurement Levels

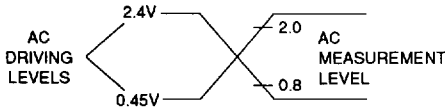

$t_R, t_F < 20$ ns (10% to 90%)

Output Test Load

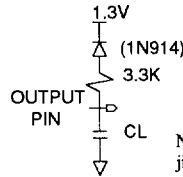

Note: $C_L = 100$ pF including jig capacitance.

Pin Capacitance ($f = 1$ MHz, $T = 25^\circ\text{C}$) ⁽¹⁾

| | Typ | Max | Units | Conditions |
|-----------|-----|-----|-------|-----------------|
| C_{IN} | 4 | 6 | pF | $V_{IN} = 0$ V |
| C_{OUT} | 8 | 12 | pF | $V_{OUT} = 0$ V |

Notes: 1. Typical values for nominal supply voltage. This parameter is only sampled and is not 100% tested.

Programming Waveforms ⁽¹⁾

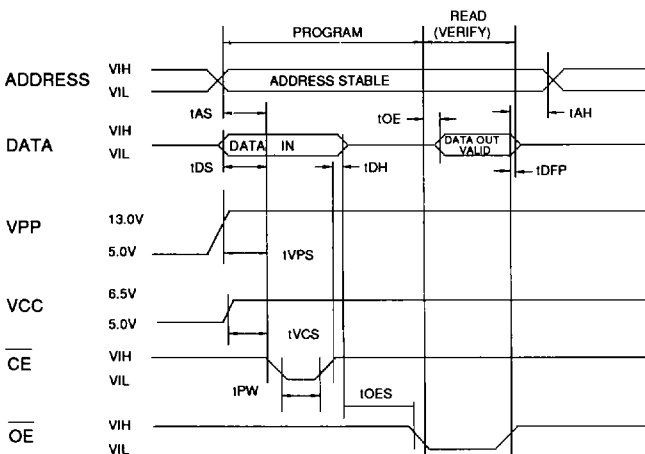

Notes:

1. The Input Timing Reference is 0.8 V for V_{IL} and 2.0 V for V_{IH} .
2. t_{OE} and t_{DFP} are characteristics of the device but must be accommodated by the programmer.
3. When programming the AT27C256R a 0.1- μF capacitor is required across V_{pp} and ground to suppress spurious voltage transients.

D.C. Programming Characteristics

$T_A = 25 \pm 5^\circ\text{C}$, $V_{CC} = 6.5 \pm 0.25\text{ V}$, $V_{PP} = 13.0 \pm 0.25\text{ V}$

| Sym- bol | Parameter | Test Conditions | Limits | | Units |
|------------------|--|---------------------------|--------|------------|---------------|
| | | | Min | Max | |
| I _{LI} | Input Load Current | $V_{IN}=V_{IL}, V_{IH}$ | | 10 | μA |
| V _{IL} | Input Low Level | (All Inputs) | -0.6 | 0.8 | V |
| V _{IH} | Input High Level | | 2.0 | $V_{CC}-1$ | V |
| V _{OL} | Output Low Volt. | $I_{OL}=2.1\text{ mA}$ | | .45 | V |
| V _{OH} | Output High Volt. | $I_{OH}=400\ \mu\text{A}$ | 2.4 | | V |
| I _{CC2} | V _{CC} Supply Current (Program and Verify) | | | 25 | mA |
| I _{PP2} | V _{PP} Current | $\overline{CE}=V_{IL}$ | | 25 | mA |
| V _{ID} | A9 Product Identification Voltage | | 11.5 | 12.5 | V |

A.C. Programming Characteristics

$T_A = 25 \pm 5^\circ\text{C}$, $V_{CC} = 6.5 \pm 0.25\text{ V}$, $V_{PP} = 13.0 \pm 0.25\text{ V}$

| Sym- bol | Parameter | Test Conditions* (see Note 1) | Limits | | Units |
|------------------|---|-------------------------------------|--------|-----|---------------|
| | | | Min | Max | |
| t _{AS} | Address Setup Time | | 2 | | μs |
| t _{OES} | \overline{OE} Setup Time | | 2 | | μs |
| t _{DS} | Data Setup Time | | 2 | | μs |
| t _{AH} | Address Hold Time | | 0 | | μs |
| t _{DH} | Data Hold Time | | 2 | | μs |
| t _{DFP} | \overline{OE} High to Out- put Float Delay | (Note 2) | 0 | 130 | ns |
| t _{VPS} | V _{PP} Setup Time | | 2 | | μs |
| t _{VCS} | V _{CC} Setup Time | | 2 | | μs |
| t _{PW} | \overline{CE} Program Pulse Width | (Note 3) | 95 | 105 | μs |
| t _{OE} | Data Valid from \overline{OE} | (Note 2) | | 150 | ns |

*A.C. Conditions of Test:

Input Rise and Fall Times (10% to 90%) 20 ns
 Input Pulse Levels 0.45 V to 2.4 V
 Input Timing Reference Level 0.8 V to 2.0 V
 Output Timing Reference Level 0.8 V to 2.0 V

Notes:

- V_{CC} must be applied simultaneously or before V_{PP} and removed simultaneously or after V_{PP}.
- This parameter is only sampled and is not 100% tested. Output Float is defined as the point where data is no longer driven — see timing diagram.
- Program Pulse width tolerance is 100 $\mu\text{s} \pm 5\%$.

Atmel's 27C256R Integrated Product Identification Code

| Codes | Pins | | | | | | | | | | Hex Data |
|--------------|------|----|----|----|----|----|----|----|----|--|-------------|
| | A0 | O7 | O6 | O5 | O4 | O3 | O2 | O1 | O0 | | |
| Manufacturer | 0 | 0 | 0 | 0 | 1 | 1 | 1 | 1 | 0 | | 1E |
| Device Type | 1 | 1 | 0 | 0 | 0 | 1 | 1 | 0 | 0 | | 8C |

Rapid Programming Algorithm

A 100 μs \overline{CE} pulse width is used to program. The address is set to the first location. V_{CC} is raised to 6.5 V and V_{PP} is raised to 13.0 V. Each address is first programmed with one 100 μs \overline{CE} pulse without verification. Then a verification/reprogramming loop is executed for each address. In the event a byte fails to pass verification, up to 10 successive 100 μs pulses are applied with a verification after each pulse. If the byte fails to verify after 10 pulses have been applied, the part is considered failed. After the byte verifies properly, the next address is selected until all have been checked. V_{PP} is then lowered to 5.0 V and V_{CC} to 5.0 V. All bytes are read again and compared with the original data to determine if the device passes or fails.

4

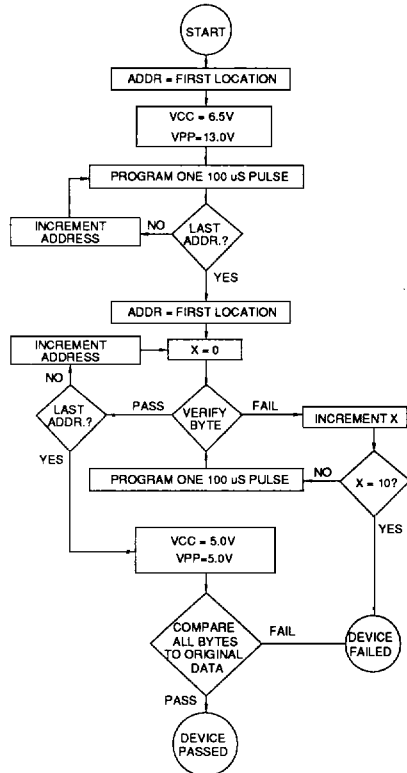



Ordering Information

| I _{acc} (ns) | I _{cc} (mA) | | Ordering Code | Package | Operation Range |
|--------------------------|----------------------|---------|--|---|---|
| | Active | Standby | | | |
| 70 | 20 | 0.1 | AT27C256R-70DC AT27C256R-70KC AT27C256R-70LC | 28DW6 32KW 32LW | Commercial (0°C to 70°C) |
| 70 | 25 | 0.2 | AT27C256R-70DI AT27C256R-70KI AT27C256R-70LI | 28DW6 32KW 32LW | Industrial (-40°C to 85°C) |
| 90 | 20 | 0.1 | AT27C256R-90DC AT27C256R-90JC AT27C256R-90KC AT27C256R-90LC AT27C256R-90PC AT27C256R-90RC | 28DW6 32J 32KW 32LW 28P6 28R | Commercial (0°C to 70°C) |
| 90 | 25 | 0.2 | AT27C256R-90DI AT27C256R-90JI AT27C256R-90KI AT27C256R-90LI AT27C256R-90PI AT27C256R-90RI | 28DW6 32J 32KW 32LW 28P6 28R | Industrial (-40°C to 85°C) |
| | | | AT27C256R-90DM AT27C256R-90KM AT27C256R-90LM | 28DW6 32KW 32LW | Military (-55°C to 125°C) |
| | | | AT27C256R-90DM/883 AT27C256R-90KM/883 AT27C256R-90LM/883 | 28DW6 32KW 32LW | Military/883C Class B, Fully Compliant (-55°C to 125°C) |
| 120 | 20 | 0.1 | AT27C256R-12DC AT27C256R-12JC AT27C256R-12KC AT27C256R-12LC AT27C256R-12PC AT27C256R-12RC | 28DW6 32J 32KW 32LW 28P6 28R | Commercial (0°C to 70°C) |
| 120 | 25 | 0.2 | AT27C256R-12DI AT27C256R-12JI AT27C256R-12KI AT27C256R-12LI AT27C256R-12PI AT27C256R-12RI | 28DW6 32J 32KW 32LW 28P6 28R | Industrial (-40°C to 85°C) |
| | | | AT27C256R-12DM AT27C256R-12KM AT27C256R-12LM | 28DW6 32KW 32LW | Military (-55°C to 125°C) |
| | | | AT27C256R-12DM/883 AT27C256R-12KM/883 AT27C256R-12LM/883 | 28DW6 32KW 32LW | Military/883C Class B, Fully Compliant (-55°C to 125°C) |
| 150 | 20 | 0.1 | AT27C256R-15DC AT27C256R-15JC AT27C256R-15KC AT27C256R-15LC AT27C256R-15PC AT27C256R-15RC | 28DW6 32J 32KW 32LW 28P6 28R | Commercial (0°C to 70°C) |

Ordering Information

| t _{ACC} (ns) | I _{CC} (mA) | | Ordering Code | Package | Operation Range |
|--------------------------|----------------------|---------|--|---|---|
| | Active | Standby | | | |
| 150 | 25 | 0.2 | AT27C256R-15DI AT27C256R-15JI AT27C256R-15KI AT27C256R-15LI AT27C256R-15PI AT27C256R-15RI | 28DW6 32J 32KW 32LW 28P6 28R | Industrial (-40°C to 85°C) |
| | | | AT27C256R-15DM AT27C256R-15KM AT27C256R-15LM | 28DW6 32KW 32LW | Military (-55°C to 125°C) |
| | | | AT27C256R-15DM/883 AT27C256R-15KM/883 AT27C256R-15LM/883 | 28DW6 32KW 32LW | Military/883C Class B, Fully Compliant (-55°C to 125°C) |
| 200 | 20 | 0.1 | AT27C256R-20DC AT27C256R-20JC AT27C256R-20KC AT27C256R-20LC AT27C256R-20PC AT27C256R-20RC | 28DW6 32J 32KW 32LW 28P6 28R | Commercial (0°C to 70°C) |
| 200 | 25 | 0.2 | AT27C256R-20DI AT27C256R-20JI AT27C256R-20KI AT27C256R-20LI AT27C256R-20PI AT27C256R-20RI | 28DW6 32J 32KW 32LW 28P6 28R | Industrial (-40°C to 85°C) |
| | | | AT27C256R-20DM AT27C256R-20KM AT27C256R-20LM | 28DW6 32KW 32LW | Military (-55°C to 125°C) |
| | | | AT27C256R-20DM/883 AT27C256R-20KM/883 AT27C256R-20LM/883 | 28DW6 32KW 32LW | Military/883C Class B, Fully Compliant (-55°C to 125°C) |
| 250 | 20 | 0.1 | AT27C256R-25DC AT27C256R-25JC AT27C256R-25KC AT27C256R-25LC AT27C256R-25PC AT27C256R-25RC | 28DW6 32J 32KW 32LW 28P6 28R | Commercial (0°C to 70°C) |
| 250 | 25 | 0.2 | AT27C256R-25DI AT27C256R-25JI AT27C256R-25KI AT27C256R-25LI AT27C256R-25PI AT27C256R-25RI | 28DW6 32J 32KW 32LW 28P6 28R | Industrial (-40°C to 85°C) |
| | | | AT27C256R-25DM AT27C256R-25KM AT27C256R-25LM | 28DW6 32KW 32LW | Military (-55°C to 125°C) |
| | | | AT27C256R-25DM/883 AT27C256R-25KM/883 AT27C256R-25LM/883 | 28DW6 32KW 32LW | Military/883C Class B, Fully Compliant (-55°C to 125°C) |



Ordering Information

| t _{ACC} (ns) | I _{CC} (mA) | | Ordering Code | Package | Operation Range |
|--------------------------|----------------------|---------|--|-----------------------|---|
| | Active | Standby | | | |
| 90 | 25 | 0.2 | 5962-86063 07 XX 5962-86063 07 YX 5962-86063 07 ZX | 28DW6 32LW 32KW | Military/883C Class B, Fully Compliant (-55°C to 125°C) |
| 120 | 25 | 0.2 | 5962-86063 06 XX 5962-86063 06 YX 5962-86063 06 ZX | 28DW6 32LW 32KW | Military/883C Class B, Fully Compliant (-55°C to 125°C) |
| 150 | 25 | 0.2 | 5962-86063 05 XX 5962-86063 05 YX 5962-86063 05 ZX | 28DW6 32LW 32KW | Military/883C Class B, Fully Compliant (-55°C to 125°C) |
| 170 | 25 | 0.2 | 5962-86063 04 XX 5962-86063 04 YX 5962-86063 04 ZX | 28DW6 32LW 32KW | Military/883C Class B, Fully Compliant (-55°C to 125°C) |
| 200 | 25 | 0.2 | 5962-86063 01 XX 5962-86063 01 YX 5962-86063 01 ZX | 28DW6 32LW 32KW | Military/883C Class B, Fully Compliant (-55°C to 125°C) |
| 250 | 25 | 0.2 | 5962-86063 02 XX 5962-86063 02 YX 5962-86063 02 ZX | 28DW6 32LW 32KW | Military/883C Class B, Fully Compliant (-55°C to 125°C) |
| 300 | 25 | 0.2 | 5962-86063 03 XX 5962-86063 03 YX 5962-86063 03 ZX | 28DW6 32LW 32KW | Military/883C Class B, Fully Compliant (-55°C to 125°C) |

| t _{ACC} (ns) | I _{CC} (mA) | | Ordering Code | Package | Operation Range |
|--------------------------|----------------------|---------|----------------|---------|-----------------------------|
| | Active | Standby | | | |
| 90 | 20 | 0.1 | AT27C256R-90TC | 28T | Commercial (0°C to 70°C) |
| 120 | 20 | 0.1 | AT27C256R-12TC | 28T | Commercial (0°C to 70°C) |
| 150 | 20 | 0.1 | AT27C256R-15TC | 28T | Commercial (0°C to 70°C) |
| 200 | 20 | 0.1 | AT27C256R-20TC | 28T | Commercial (0°C to 70°C) |
| 250 | 20 | 0.1 | AT27C256R-25TC | 28T | Commercial (0°C to 70°C) |

Ordering Information

| Package Type | |
|---------------------|--|
| 28DW6 | 28 Lead, 0.600" Wide, Windowed, Ceramic Dual Inline Package (Cerdip) |
| 32J | 32 Lead, Plastic J-Leaded Chip Carrier OTP (PLCC) |
| 32KW | 32 Lead, Windowed, Ceramic J-Leaded Chip Carrier (JLCC) |
| 32LW | 32 Pad, Windowed, Ceramic Leadless Chip Carrier (LCC) |
| 28P6 | 28 Lead, 0.600" Wide, Plastic Dual Inline Package OTP (PDIP) |
| 28R | 28 Lead, 0.330" Wide, Plastic Gull Wing Small Outline OTP (SOIC) |
| 28T | 28 Lead, Plastic Thin Small Outline Package OTP (TSOP) |

