



PRELIMINARY

Data Sheet

ENMods™

Component Power Front End System for EN Compliance

Features

- Harmonic Current Attenuation to EN61000-3-2
- EMI Filtering to EN55022, Level B
- Transient Immunity to EN61000-4-5
- 575W Rated Power Output
- Autoranging 115/230Vac Input
- Microprocessor Control
- Inrush Current Limiting

Product Highlights

The ENMods system is a new AC front end solution for compliance to electromagnetic compatibility (EMC) standards. It consists of the MiniHAM — a passive harmonic attenuation module and the FARM3 — an auto ranging AC-DC front end module. Combined with the filtering and hold-up capacitors as specified herein, the ENMods system provides full compliance to:

- EN61000-3-2 Harmonic Current
- EN55022, Level B Conducted Emissions
- EN61000-4-5 Surge Immunity
- EN61000-4-11 Line Disturbances

The MiniHAM is the first passive product specifically designed for compliance to EN harmonic current limits. Unlike active PFC solutions, the MiniHAM generates no EMI, greatly simplifying and reducing system noise filtering requirements. It is also considerably smaller and more efficient than active alternatives and improves MTBF by an order of magnitude. Optimized for operation on the DC bus (provided by the FARM3) rather than directly on the AC line, it will provide harmonic current compliance up to 600W of input power at 230Vac.

The 115/230Vac input FARM3 is a new member of Vicor's Filter and Autoranging Module product line that has been optimized for use as the front end for the MiniHAM. Both modules are in Vicor's standard Mini half-brick package. Together with Vicor's 1st or 2nd Generation 300V input DC-DC converters, they form the basis of a low noise, high efficiency, rugged, simple and reliable EN compliant power system.

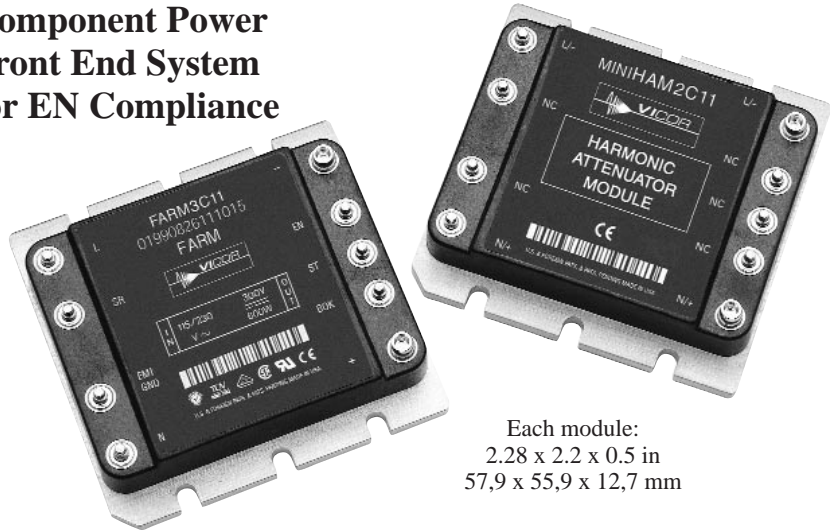

Each module:
2.28 x 2.2 x 0.5 in
57,9 x 55,9 x 12,7 mm

Absolute Maximum Ratings

Parameter	Rating	Unit	Notes
L to N voltage (FARM3)	264	Vrms	Continuous
L to N voltage (FARM3)	280	Vrms	100ms
+Out to -Out voltage (FARM3)	400	Vdc	
BOK to -Out voltage (FARM3)	16	Vdc	
EN to -Out voltage (FARM3)	16	Vdc	
Mounting torque	4-6(0.45-0.68)	in-lbs (N-m)	6 each, 4-40 screw
Pin soldering temperature	500 (260)	°F (°C)	<5 sec; wave solder
Pin soldering temperature	750 (390)	°F (°C)	<7 sec; hand solder
Output current	3.5	A	

Thermal Resistance

Parameter	Typ	Unit
Baseplate to sink; flat, greased surface	0.16	°C/Watt
Baseplate to sink; with thermal pad (P/N 20264)	0.14	°C/Watt
Baseplate to ambient	8.0	°C/Watt
Baseplate to ambient; 1000 LFM	1.9	°C/Watt

Part Numbering

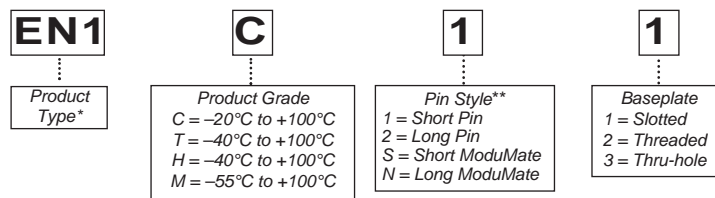

*EN1 product includes one each MiniHAM and FARM3 with same product grade, pin and baseplate style.
**Pin styles S & N are compatible with the ModuMate interconnect system for socketing and surface mounting.

PRELIMINARY

Electrical Characteristics

Electrical characteristics apply over the full operating range of input voltage, output power and baseplate temperature, unless otherwise specified. All temperatures refer to the operating temperature at the center of the baseplate. Performance specifications are based on the ENMods system as shown in Figure 1a.

■ FARM3 MODULE SPECIFICATIONS (see Figure 3 thru Figure 7 for operating characteristics)

Parameter	Min	Typ	Max	Unit	Notes
Operating input voltage	90	115	132	Vac	Autoranging (doubler mode)
Operating input voltage	180	230	264	Vac	Autoranging (bridge mode)
Input undervoltage			90	Vac	No damage
AC line frequency	47		63	Hz	C-, T-, H- and M-Grade
Power factor	0.68	0.72			Typical line
Inrush current			30	Amps	264Vac line voltage
Efficiency	94	96		%	Full load
AC Bus OK (BOK)					
Low state resistance			15	Ω	To negative output - Bus normal
Low state current			50	mA	Bus normal
High state voltage	14.8	15.0	15.2	Vdc	Bus abnormal, 27k internal pull up to 15Vdc (see Figure12)
BOK true threshold	235	240	245	Vdc	Output Bus voltage
BOK false threshold	200	205	210	Vdc	Output Bus voltage
Module Enable (EN)					
Low state resistance			15	Ω	To negative output - Converters disabled
Low state current			50	mA	
High state voltage	14.8	15.0	15.2	Vdc	150k internal pull up to 15Vdc (see Figure 11)
Enable threshold	235	240		Vdc	Output bus voltage
Disable threshold	185	190	195	Vdc	Output bus voltage
AC Bus OK - Module Enable, differential error*	15	17	20	Vdc	AC Bus OK and Module Enable thresholds track

* Tracking error between BUS OK and Enable thresholds

■ MINIHAM MODULE SPECIFICATIONS (when used in accordance with Figure 1a)

Parameter	Min	Typ	Max	Unit	Notes
Output power	0		575	Watts	
Efficiency @ 115Vac	93	94		%	Full load
Efficiency @ 230Vac	96	97		%	Full load
Output voltage	250		375	Vdc	
External hold-up capacitance			3,300	μF	

■ ELECTROMAGNETIC COMPATIBILITY (configured as illustrated in Figures 1a and 1b)

Harmonic currents	EN61000-3-2, Amendment 14	50-625W, 230Vac input 575W output (see Figure 2)
Input line disturbances	EN61000-4-11	
Input surge withstand	EN61000-4-5	2kV–50 μs common mode 1kV–50 μs differential mode
Conducted emissions	EN55022, Level B	(See Figures 8a thru 8c)

Electrical Characteristics (continued)

MODULE GENERAL SPECIFICATIONS

Parameter	Min	Typ	Max	Unit	Notes
Safety approvals					
FARM3					TÜV + VDE EN60950, CE Marked (pending)
MiniHAM					CE Marked (pending)
Isolation (in to out)	None				Isolation provided by DC-DC converter(s)
Dielectric withstand (I/O to baseplates)	1500			Vrms	Baseplate earthed
Leakage current			2.5	mA	264Vac
MTBF		>1,000,000		Hours	25°C, Ground Benign
Baseplate material					Aluminum
Cover					Dupont Zenite / Aluminum
Pin material					
-Style 1 & 2					Copper, Tin/Lead solder dipped
-Style S & N (ModuMate compatible)					Copper, Nickel/Gold plating
Weight					
FARM3		3.1(88)		Ounces (grams)	
MiniHAM		5.1(145)		Ounces (grams)	
Size		2.25 x 2.2 x 0.5		Inches	Vicor's standard mini half-brick package
		57,9 x 55,9 x 12,7		mm	
Storage temperature					
(C-, T-Grade)	-40		+125	°C	
(H-Grade)	-55		+125	°C	
(M-Grade)	-65		+125	°C	
Operating temperature					
(C-Grade)	-20		+100	°C	Baseplate
(T-, H-Grade)	-40		+100	°C	Baseplate
(M-Grade)	-55		+100	°C	Baseplate



Figure 1a—ENMods system and DC-DC converter interconnection drawing

Operating Characteristics

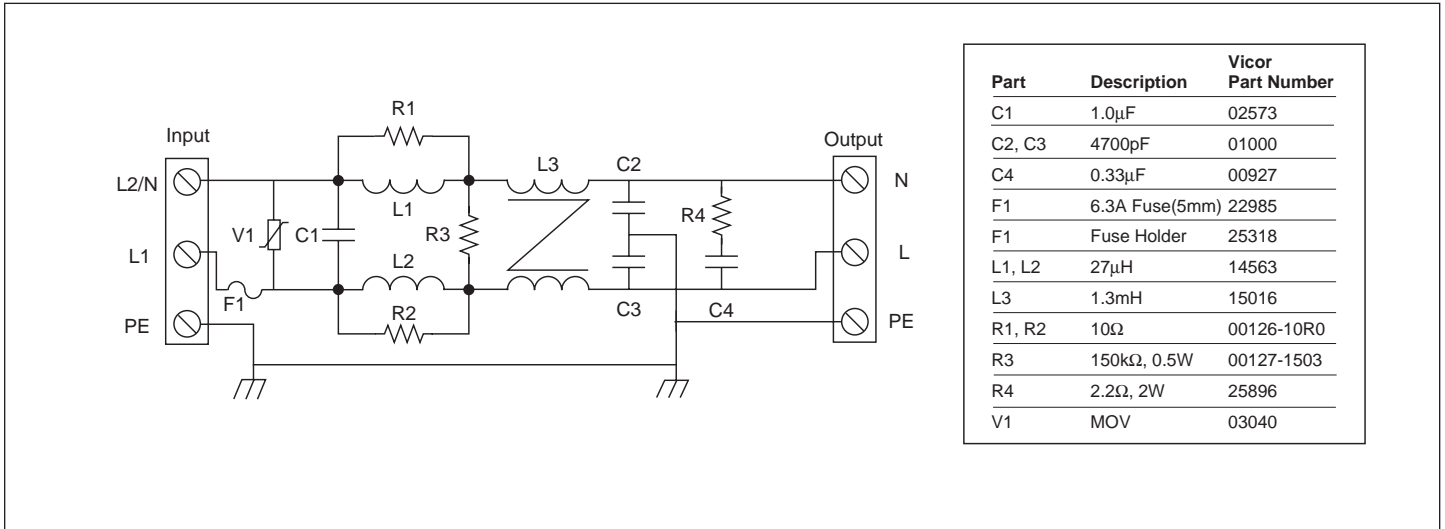

Figure 1b — Input EMI filter for EN55022, Level B compliance

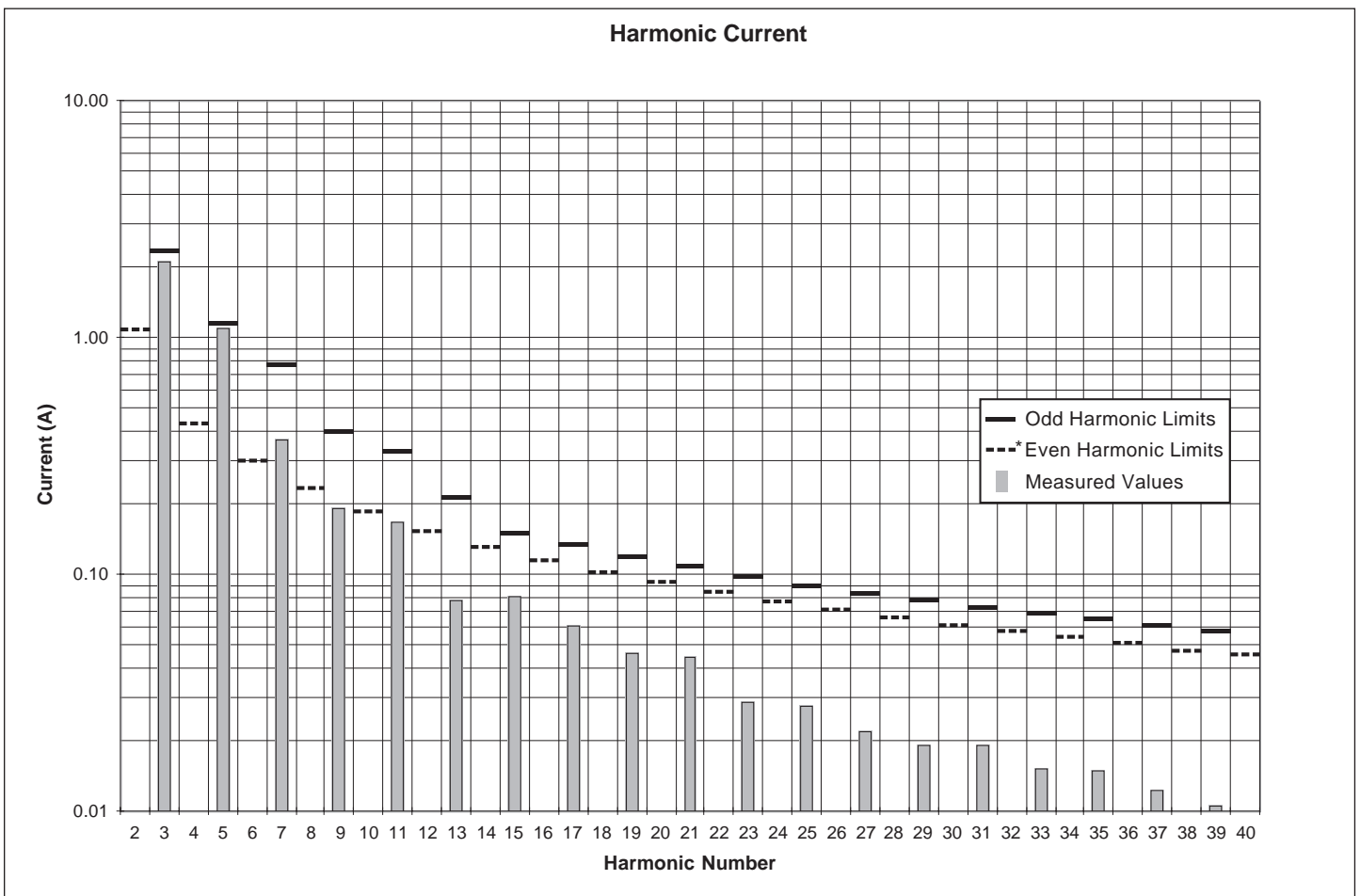

Figure 2 — Measured harmonic current at 230VAC, 575W vs. EN spec limits

*Measured values of even harmonics are below 0.01A

Operating Characteristics (FARM3)



Figure 3—Start-up at 120Vac input



Figure 4—Start-up at 240Vac input



Figure 5—Power-down from 120Vac



Figure 6—Power-down from 240Vac

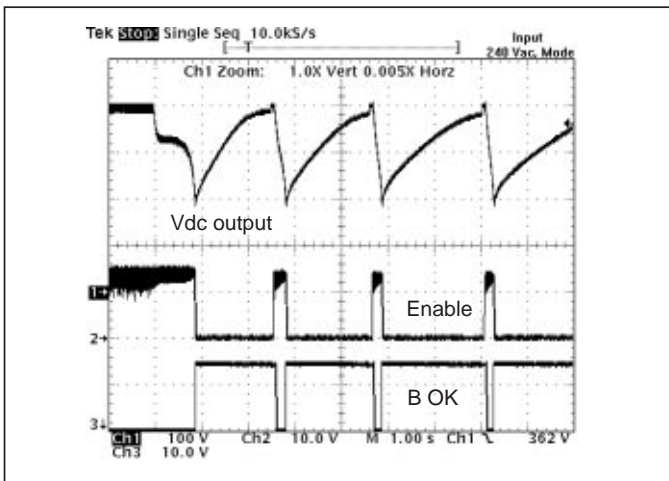

Figure 7—Output overvoltage protection 240Vac range

PRELIMINARY

Operating Characteristics (Conducted emissions relative to EN55022 Reference Figure 1a)

Quasi Peak and Average Limits

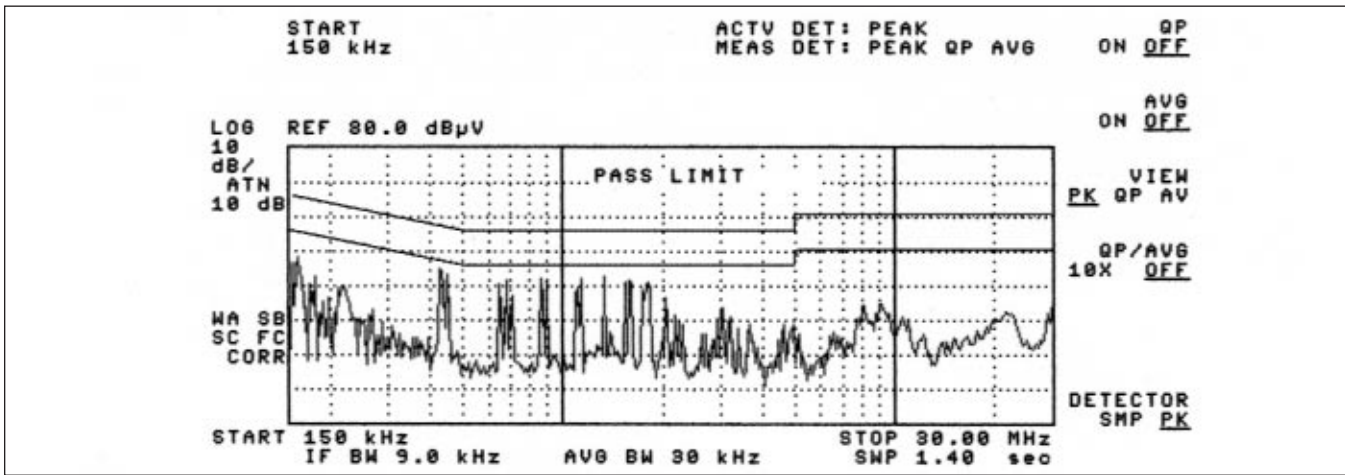

Figure 8a —Peak detection

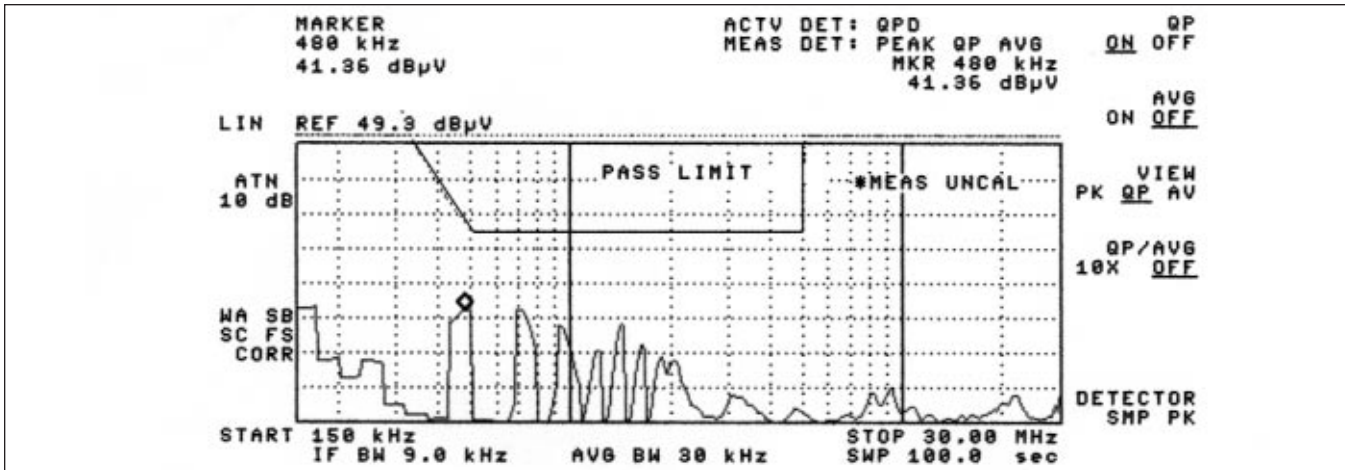

Figure 8b —Quasi peak detection

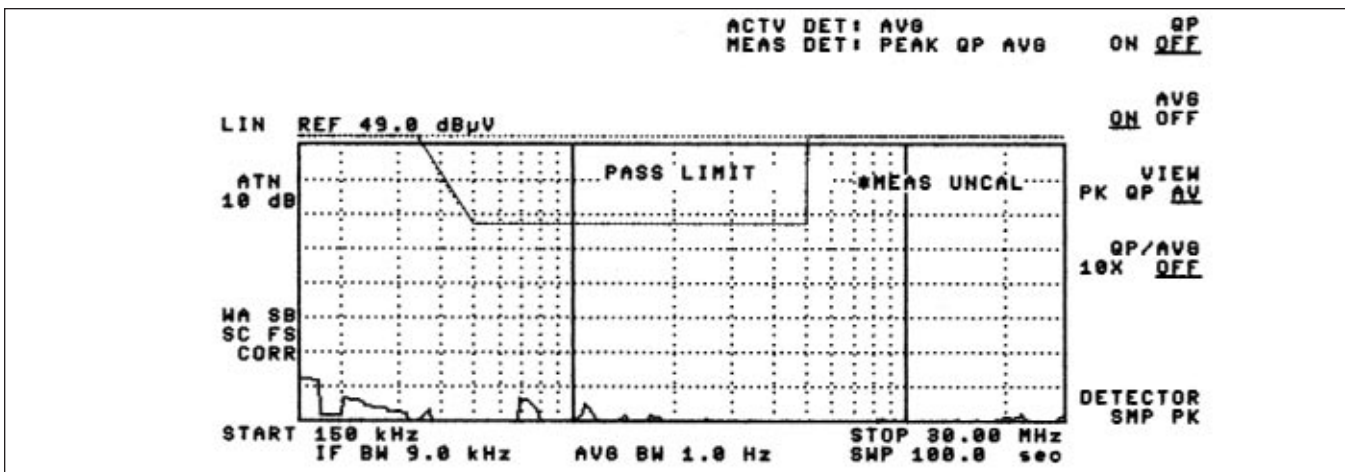

Figure 8c —Average detection

Application Note

The ENMods system provides an effective solution for the AC front end of a power supply built with Vicor DC-DC converters. This high performance power system building block satisfies a broad spectrum of requirements and agency standards.

The ENMods system provides transient/surge immunity, harmonic current attenuation and EMI filtering, in addition to all of the power switching and control circuitry necessary for autoranging rectification, inrush current limiting, and overvoltage protection. Converter enable and status functions for orderly power up/down control or sequencing are also provided. To complete the AC front end configuration, the user only needs to add hold-up capacitors, a simple EMI filter, and a few discrete components (Fig 1A).

Functional Description (FARM3, see Figures 9 & 10)

Power-Up Sequence.

- 1.1** Upon application of input power, the hold-up capacitors begin to charge. The thermistor limits the charge current, and the exponential time constant is determined by the hold-up capacitor value and the thermistor cold resistance. The slope (dv/dt) of the capacitor voltage versus time approaches zero as the capacitors become charged to the peak of the AC line voltage.

The switch that bypasses the inrush limiting PTC (positive temperature coefficient) thermistor is open when power is applied, as is the switch that engages the strap for voltage doubling. In addition, the converter modules are disabled via the Enable (EN) line, and Bus-OK (BOK) is high.

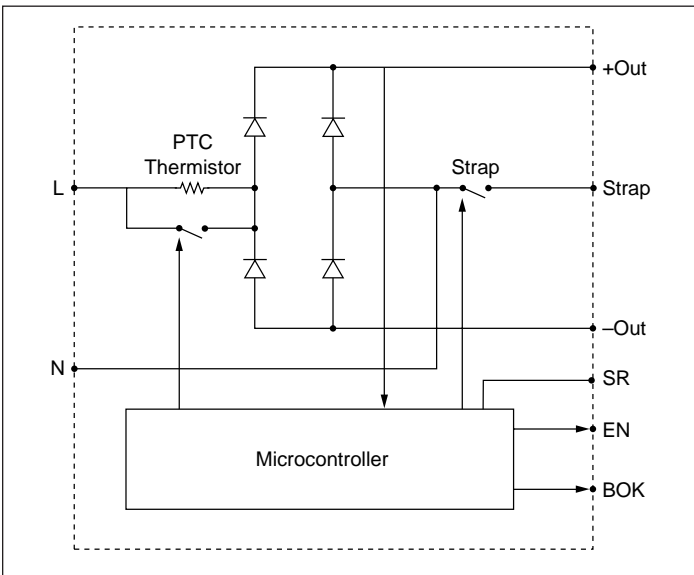

Figure 9—Functional block diagram: FARM3 module

- 2.1** If the bus voltage is less than 200V as the slope nears zero, the voltage doubler is activated, and the bus voltage climbs exponentially to twice the peak line voltage. If the bus voltage is greater than 200V, the doubler is not activated.
- 3.1** If the bus voltage is greater than 235V as the slope approaches zero, the inrush limiting thermistor is bypassed. Below 235V, it is not bypassed.
- 4.1** The converters are enabled 50 milliseconds after the thermistor bypass switch is closed.
- 5.1** Bus-OK is asserted after an additional 50 millisecond delay to allow the converter outputs to settle within specification.

Power-Down Sequence. When input power is turned off or fails, the following sequence occurs as the bus voltage decays:

- 1.2** Bus-OK is deasserted when the bus voltage falls below 210Vdc.
- 2.2** The converters are disabled when the bus voltage falls below 190Vdc. If power is reapplied after the converters are disabled, the entire power-up sequence is repeated. If a momentary power interruption occurs and power is reestablished before the bus reaches the disable threshold, the power-up sequence is not repeated, i.e., the power conversion system “rides through” the momentary interruption.

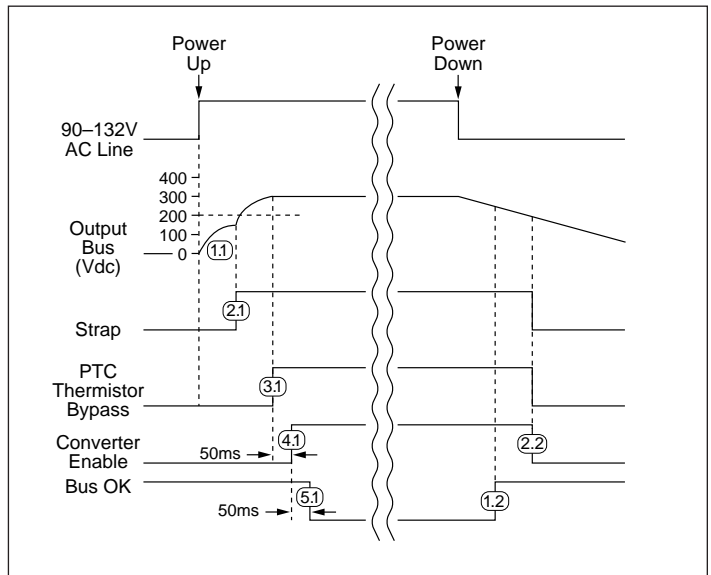

Figure 10—Timing diagram: power-up/down sequence

Application Note (continued)

Off-Line Power Supply Configuration

The ENMods system maintains the DC output bus voltage between 250 and 370Vdc over the entire input voltage range, which is compatible with all Vicor 300V input converters. Autoranging automatically switches to the proper bridge or doubler mode at startup depending on the input voltage, eliminating the possibility of damage due to improper line connection. The ENMods system is rated at 575W output power. These modules can serve as the AC front end for any number and combination of compatible converters as long as the maximum power rating is not exceeded.

Pin Descriptions (see Figure 1a)

Strap (ST) Pin. In addition to input and output power pin connections, it is necessary to connect the Strap pin to the center junction of the series hold-up capacitors ($C1$, $C2$) for proper (autoranging) operation. Varistors $V1$ and $V2$ provide capacitor protection. The bleeder resistors ($R1$, $R2$) discharge the hold-up capacitors when power is switched off. Capacitors $C7$ and $C8$ are recommended if the hold-up capacitors are located more than 3 inches from the output pins.

Enable (EN) Pin. The Enable pin must be connected to the PC or Gate-In pin of all converter modules to disable the converters during power-up. Otherwise, the converters would attempt to start while the hold-up capacitors are being charged through the current limiting thermistor, preventing the bus voltage from reaching the thermistor bypass threshold, thus disabling the power supply. The Enable output (the drain of an N channel MOSFET) is internally pulled up to 15V through a 150k Ω resistor. (see Figure 11)

A signal diode should be placed close to and in series with the PC or (Gate-In) pin of each converter to eliminate the possibility of control interference between converters. The Enable pin switches to the high state (15V) with respect to the SR pin to turn on the converters after the power-up inrush is over. The Enable function also provides input overvoltage protection for the converters by turning off the converters if the DC bus voltage exceeds 400Vdc. The thermistor bypass switch opens if this condition occurs, placing the thermistor in series with the input voltage, which reduces the bus voltage to a safe level while limiting input current in case the varistors conduct. The thermistor bypass switch also opens if a fault or overload reduces the bus voltage to less than 180Vdc. (see Figure 9)

Bus-OK (BOK) Pin. (see Figure 12) The Bus-OK pin is intended to provide early-warning power fail information and is also referenced to the SR pin.

Caution: There is no input to output isolation in the ENMods. It is necessary to monitor Bus-OK via an optoisolator if it is to be used on the secondary (output) side of the converters. A line isolation transformer should be used when performing scope measurements. Scope probes should never be applied simultaneously to the input and output as this will destroy the unit.

L, N Pins. Line and neutral input.

+, – Pins. Positive and negative outputs.

SR Pin. Signal return for BOK and EN outputs

Filter (see Figure 1b)

The input EMI filter consists of differential and common mode chokes, Y– rated capacitors (line-ground) and X– rated capacitors (line-line). This filter configuration provides sufficient common mode and differential mode insertion loss in the frequency range between 100kHz and 30MHz to comply with the Level B conducted emissions limit, as illustrated in Figures 8a thru 8c.

Hold-up Capacitors

Hold-up capacitor values should be determined according to output bus voltage ripple, power fail hold-up time, and ride-through time (see Figure 13). Many applications require the power supply to maintain output regulation during a momentary power failure of specified duration, i.e., the converters must hold-up or ride through such an event while maintaining undisturbed output voltage regulation. Similarly, many of these same systems require notification of an impending power failure in order to allow time to perform an orderly shutdown.

The energy stored on a capacitor which has been charged to voltage V is:

$$\mathcal{E} = 1/2(CV^2) \quad (1)$$

Where: \mathcal{E} = stored energy
 C = capacitance
 V = voltage across the capacitor

Energy is given up by the capacitors as they are discharged by the converters. The energy expended (the power-time product) is:

$$\mathcal{E} = P\Delta t = C(V_1^2 - V_2^2) / 2 \quad (2)$$

Where: P = operating power
 Δt = discharge interval
 V_1 = capacitor voltage at the beginning of Δt
 V_2 = capacitor voltage at the end of Δt

Rearranging Equation 2 to solve for the required capacitance:

$$C = 2P\Delta t / (V_1^2 - V_2^2) \quad (3)$$

Application Note (continued)



Figure 11—Enable (EN) function



Figure 12—Bus OK (BOK) isolated power status indicator

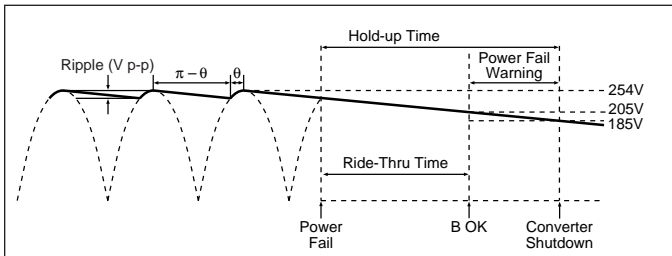

Figure 13—Hold-up time

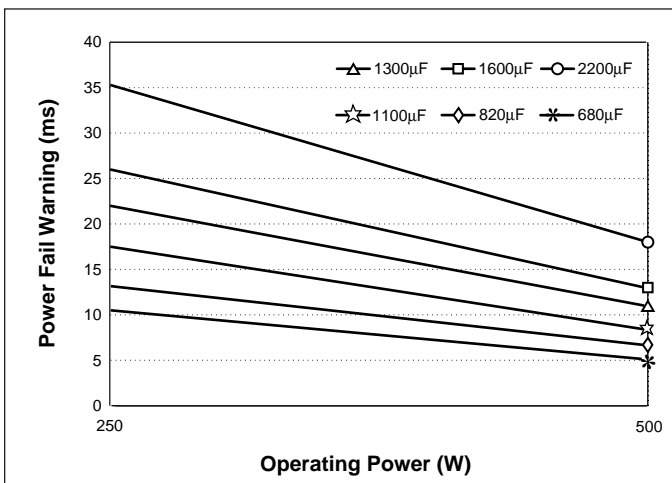

Figure 14—Hold-up time vs. operating power and total bus capacitance, series combination of C1, C2 (see Figure 1a)



Figure 15—Ride-through time vs. operating power



Figure 16—Ripple voltage vs. operating power and bus capacitance, series combination of C1, C2 (see Figure 1a)

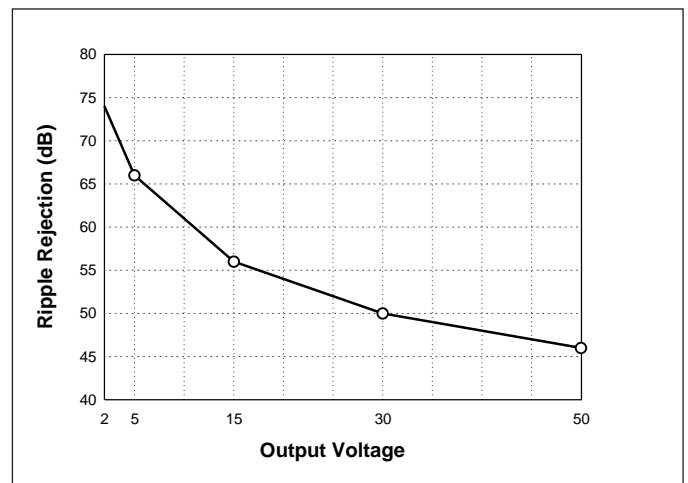

Figure 17—Converter ripple rejection vs. output voltage

Application Note (continued)

The power fail warning time (Δt) is defined as the interval between BOK and converter shutdown (EN) as illustrated in Figure 13. The Bus-OK and Enable thresholds are 205V and 185V, respectively. A simplified relationship between hold-up time, operating power, and bus capacitance is obtained by inserting these constants in equation (3):

$$C = 2P\Delta t / (205^2 - 185^2)$$

$$C = 2P\Delta t / (7,800)$$

It should be noted that the series combination ($C1, C2$, see Figure 1a) requires each capacitor to be twice the calculated value, but the required voltage rating of each capacitor is reduced to 200V.

Allowable ripple voltage on the bus (or ripple current in the capacitors) may define the capacitance requirement. Consideration should be given to converter ripple rejection and resulting output ripple voltage. The ripple rejection (R) of Vicor converters is specified as a function of the input/output voltage ratio:

$$R = 30 + 20\log(V_{in} / V_{out}) \quad (4)$$

For example, a converter whose output is 15V and nominal input is 300V will provide 56dB ripple rejection, i.e., 10V p-p of input ripple will produce 15mV p-p of output ripple (see Figure 17). Equation 3 is again used to determine the required capacitance. In this case, V_1 and V_2 are the instantaneous values of bus voltage at the peaks and valleys (see Figure 13) of the ripple, respectively. The capacitors must holdup the bus voltage for the time interval (Δt) between peaks of the rectified line as given by:

$$\Delta t = (\pi - \theta) / 2\pi f \quad (5)$$

Where: f = line frequency
 θ = rectifier conduction angle

The approximate conduction angle is given by:

$$\theta = \text{Cos}^{-1}(V_2/V_1) \quad (6)$$

Another consideration in hold-up capacitor selection is their ripple current rating. The capacitors' rating must be higher than the maximum operating ripple current. The approximate operating ripple current (rms) is given by:

$$I_{rms} = 2P/V_{ac} \quad (7)$$

Where: P = total output power
 V_{ac} = operating line voltage

Calculated values of bus capacitance for various hold-up time, ride-through time, and ripple voltage requirements are given as a function of operating power level in Figures 14, 15, and 16, respectively.

Example

In this example, the output required from the DC-DC converter at the point of load is 12Vdc at 320W. Therefore, the output power from the ENMods would be 375W (assuming a converter efficiency of 85%). The desired hold-up time is 9ms over an input range of 90 to 264Vac.

Determining Required Capacitance for Power Fail

Warning. Figure 14 is used to determine capacitance for a given power fail warning time and power level, and shows that the total bus capacitance should be at least 820 μ F. Since two capacitors are used in series, each capacitor should be at least 1,640 μ F. Note that warning time is not dependent on line voltage. A hold-up capacitor calculator is available on the Vicor website, at vicorpower.com.

Determining Ride-through Time. Figure 15 illustrates ride-through time as a function of line voltage and output power, and shows that at a nominal line of 90Vac, ride-through would be 68ms. Ride-through time is a function of line voltage.

Determining Ripple Voltage on the Hold-up Capacitors.

Figure 16 is used to determine ripple voltage as a function of operating power and bus capacitance, and shows that the ripple voltage across the hold-up capacitors will be 12V p-p.

Determining the Ripple on the Output of the DC-DC Converter.

Figure 17 is used to determine the ripple rejection of the DC-DC converter and indicates a ripple rejection of approximately 60 dB for a 12V output. Since the ripple on the bus voltage is 12Vac and the ripple rejection of the converter is 60 dB, the output ripple of the converter due to ripple on its input (primarily 120 Hz) will be 12mV p-p. Note that 2nd Generation converters have greater ripple rejection than either VI-200s or VI-J00s.

A variety of hold-up capacitor assemblies (HUBs) are available. Please visit the Vicor website @ vicorpower.com.

For more information about designing an autoranging AC input power supply using the ENMods and Vicor DC-DC converter modules, contact Vicor Applications Engineering at the nearest Vicor Technical Support Center, or send E-mail to apps@vicorpower.com.

• • •

Mechanical Diagram



Pin No.	FARM3		MiniHAM	
	Function	Label	Function	Label
1	Neutral	N	Neutral /+ In	N/+
2	EMI	GND	NC	NC
3	Signal Return	SR	NC	NC
4	Line	L	Line /- In	L/-
5	-Out	-	Line /- Out	L/-
6	Enable	EN	NC	NC
7	Strap	ST	NC	NC
8	BUS OK	BOK	NC	NC
9	+Out	+	Neutral /+ Out	N/+

PCB Mounting Specifications

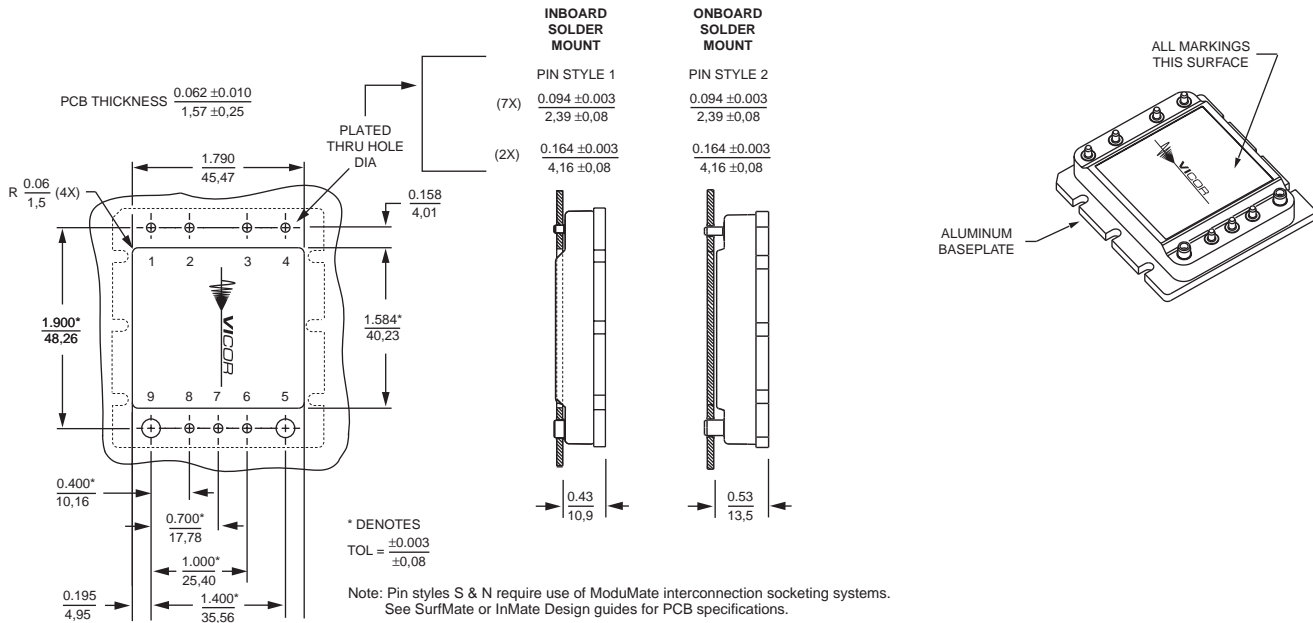

Vicor's comprehensive line of power solutions includes modular, high density DC-DC converters and accessory components, configurable power supplies, and custom power systems.

Information furnished by Vicor is believed to be accurate and reliable. However, no responsibility is assumed by Vicor for its use. No license is granted by implication or otherwise under any patent or patent rights of Vicor. Vicor components are not designed to be used in applications, such as life support systems, wherein a failure or malfunction could result in injury or death. All sales are subject to Vicor's Terms and Conditions of Sale, which are available upon request.

Specifications are subject to change without notice.



*Component Solutions
for Your Power System*

Vicor Corporation
25 Frontage Road
Andover, MA, USA 01810
Tel: 800-735-6200
Fax: 978-475-6715

Email

Vicor Express: vicorexp@vicr.com
Technical Support: apps@vicr.com