

# Kingbright Electronic Co., Ltd.



Mail Address: P. O. Box 81-153 Taipei, Taiwan  
 Telex No. : 22249 TWNKIN

Cable Address : "TWNKIN" Taipei  
 Telephones : 715-2848 • 713-0682

2 x 4.5mm RECTANGULAR LED LAMP

L-193

Unit: mm

Tolerance:  $\pm 0.2$

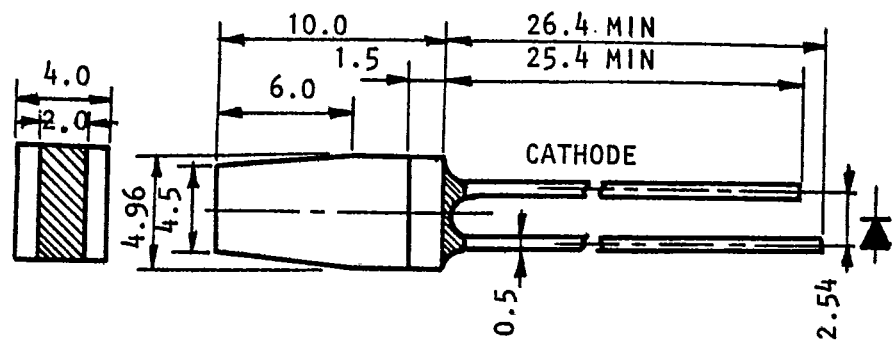

✓ New

**SELECTION GUIDE**

PART NO.	SOURCE (DICE)	LENSE TYPE (RESIN)	AXIAL LUMINOUS INTENSITY IN MCD @ 20mA		VIEWING ANGLE
			MIN	TYP	
✓ L-193HD	RED HIGH EFFICIENCY (GaP)	Red Diffused	0.5	2.2	120°
✓ L-193ID	RED HIGH INTENSITY (GaAsP/GaP)	Red Diffused	1.5	5.0	120°
✓ L-193GD	GREEN (GaP)	Green Diffused	1.0	3.5	120°
✓ L-193YD	YELLOW (GaAsP/GaP)	Yellow Diffused	1.0	4.0	120°
✓ L-193ED	ORANGE (GaAsP/GaP)	Orange Diffused	1.5	5.0	120°