

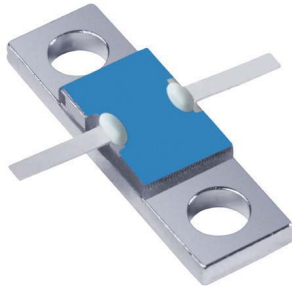

### Flangeless Attenuator 100 Watts



#### General Specifications

<b>Resistive Element</b>	Thick film
<b>Substrate</b>	Aluminum Nitride ceramic
<b>Mounting Flange</b>	Copper, Nickel plated per QQ-N-290
<b>Lead(s):</b>	99.99% pure silver (.005" thick)

#### Electrical Specifications

<b>Attenuation Range:</b>	1, 2, 3, 4, 5, 6, 10, 20 or 30 dB
<b>Frequency Range;</b>	DC – See Chart
<b>Power:</b>	100 Watts
<b>VSWR</b>	1.25:1

**Note:** Tolerance is  $\pm 0.010"$ , unless otherwise specified. Designed to meet or exceed applicable portions of MIL-E-5400. Operating temperature is  $-55^{\circ}\text{C}$  to  $150^{\circ}\text{C}$  (see chart for derating temperatures).  
All dimensions in inches.

**Specifications subject to change with out notice.**

#### Features:

- DC – 3.0 GHz
- 100 Watts
- AIN Ceramic
- Non-Nichrome Resistive Element
- Low VSWR
- 100% Tested

#### Outline Drawing

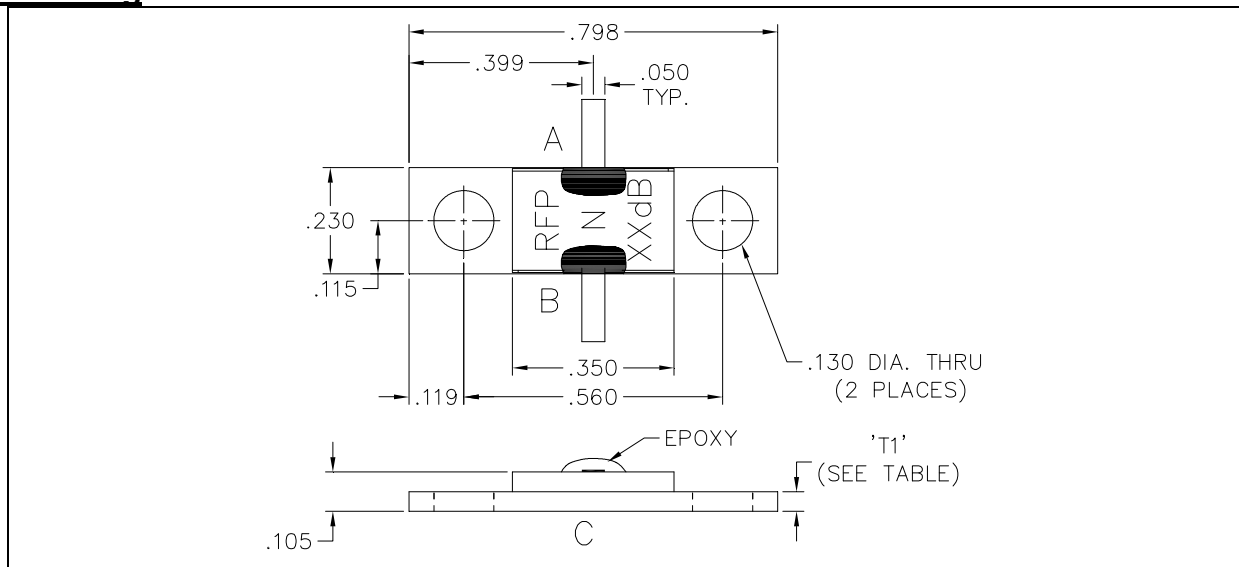

100NXXAE (097) Rev D

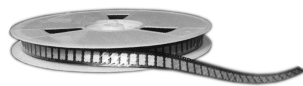



### Typical Performance:

RESISTOR VALUE CHART							
ATTENUATION	VALUE (A-B)	VALUE (A-C)	VALUE (B-C)	TOL.	FREQUENCY	R.F.P. STOCK P/N	'T1'
1dB±0.25dB	4.8Ω	435 Ω	435 Ω	±4%	DC-2.2GHz.	RFP-100N1AE	.042
2dB±0.40dB	9.6Ω	232 Ω	232 Ω	±4%	DC-2.2GHz.	RFP-100N2AE	.042
3dB±0.40dB	15.2Ω	155 Ω	155 Ω	±4%	DC-2.5GHz.	RFP-100N3AE	.042
4dB±0.40dB	22 Ω	151Ω	151Ω	±4%	DC-2.5GHz.	RFP-100N4AE	.042
5dB±0.40dB	28.5Ω	94.7Ω	94.7Ω	±4%	DC-3.0GHz.	RFP-100N5AE	.042
6dB±0.40dB	33.7Ω	82.5 Ω	82.5 Ω	±4%	DC-3.0GHz.	RFP-100N6AE	.042
9dB±0.75dB	50.6Ω	64.1Ω	64.1Ω	±4%	DC-2.2GHz.	RFP-100N9AE	.042
10dB±0.75dB	54.0Ω	59.8Ω	59.8Ω	±4%	DC-2.2GHz.	RFP-100N10AE	.042
20dB±0.50dB	81.7Ω	50.9 Ω	50.9 Ω	±4%	DC-2.0GHz.	RFP-100N20AE	.062
30dB±1.00dB	94 Ω	50.1Ω	50.1Ω	±4%	DC-2.5GHz.	RFP-100N30AE	.062

### Power De-rating:

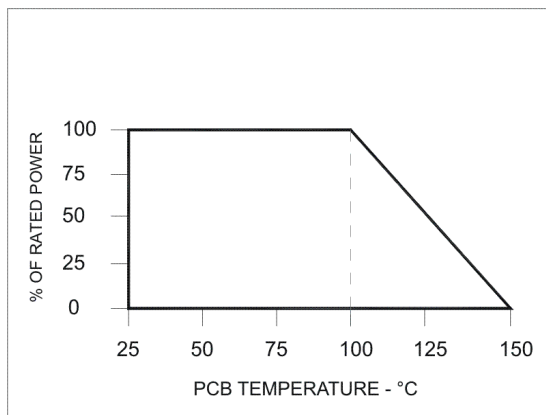

### Mounting Footprint and Procedure:

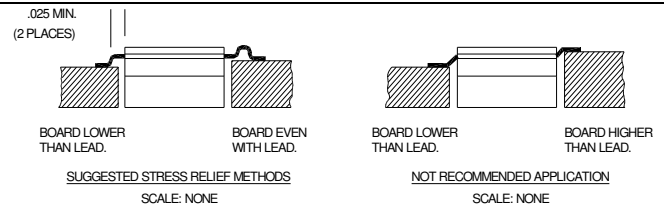

#### SUGGESTED MOUNTING PROCEDURES:

1. MAKE SURE THAT THE DEVICES ARE MOUNTED ON FLAT SURFACES (.001" UNDER THE DEVICE) TO OPTIMIZE THE HEAT TRANSFER.
2. DRILL & TAP THE HEATSINK FOR THE APPROPRIATE THREAD SIZE TO BE USED.
3. COAT HEATSINK WITH A MINIMUM AMOUNT OF HIGH QUALITY SILICONE GREASE (.001" MAX. THICKNESS).
4. POSITION DEVICE ON MOUNTING SURFACE & SECURE USING SOCKET HEAD SCREWS, FLAT & SPLIT WASHER. TORQUE SCREWS TO THE APPROPRIATE VALUE. MAKE SURE THAT THE DEVICE IS FLAT AGAINST THE HEATSINK. (CARE SHOULD BE TAKEN TO AVOID UPWARD PRESSURE OF THE LEADS TOWARDS THE LID).
5. SOLDER LEADS IN PLACE USING APPROPRIATE SOLDER WITH A CONTROLLED TEMPERATURE IRON.

\*\* FOR MORE DETAILS CONTACT FACTORY \*\*

100NXXAE (097) Rev D

USA/Canada: (315) 432-8909  
Toll Free: (800) 544-2414  
Europe: +44 2392-232392

Available on Tape and Reel For Pick and Place Manufacturing.

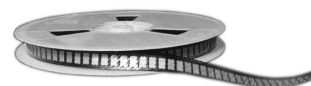

**Anaren**  
What'll we think of next?™