



Features

- InGaAs/InP PIN Photodiode with trans-impedance amplifier
- High Sensitivity with AGC*
- Differential ended output
- Single +3.3V operation
- -40~85°C operating temperature

Packaging

- FC/ST/SC receptacle package
- SM/MM fiber pigtailed with optional FC/ST/SC connector

Application

- 1.25Gbps SDH/SONET/ATM receivers
- RoHS Compliant available

Absolute Maximum Ratings (Tc=25°C)

Parameter	Symbol	Rating	Unit
Supply Voltage	V _{cc}	4.5	V
Operating Temperature	T _{opr}	-40 ~ 85	°C
Storage Temperature	T _{stg}	-40 ~ 85	°C

DC Electrical Characteristics (Tc=25°C)

Parameter	Symbol	Min.	Typ.	Max.	Unit
Power Supply	V _{cc}	3	3.3	3.6	V
Differential Output Voltage	V _d	185	250	415	mV
Supply Current (no load)	I _{cc}	-	26	50	mA

(Operating at V_{cc}=3.3V , Tc=25°C, λ=1310nm, 9/125 μm SM & 50/125 μm MM fiber)

Parameter	Symbol	Min.	Typ.	Max.	Unit	Notes
Detection Range		1100	1310	1650	nm	-
Gain@10Mbps differential	G	1.92	2.5	3.4	V/mW	Measure differentially with 30uAp-p signal
Bandwidth (to -3dB point)	BW	700	920	1100	MHz	-
Saturation Power	P _{sat}	-3	0	-	dBm	BER<10 ⁻¹² @1.25Gbps, PRBS 2 ⁷ -1, E _r =10dB
Sensitivity	Sens	-	-26	-23	dBm	BER<10 ⁻¹² @1.25Gbps, PRBS 2 ⁷ -1, E _r =10dB
Output Resistance	R _{out}	48	50	62	Ω	-

- Note: 1. Pin assignment can be customized.**
2. Specifications subject to change without notice.

Pinout Assignment

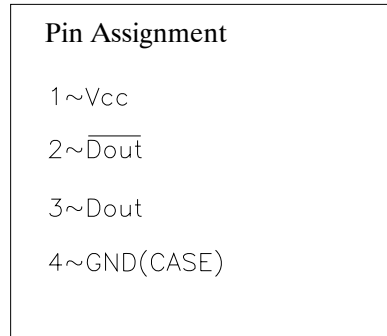
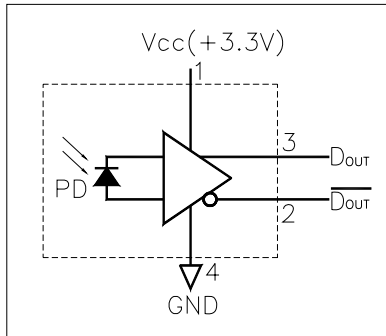

Mechanic Dimension (Units in mm)

Part Number: T-11-1250-R3-XXX-XX

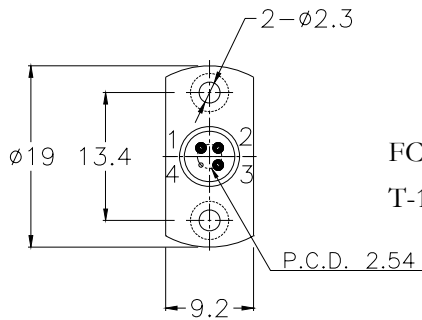

FC Receptacle
T-11-1250-R3-XFC-XX

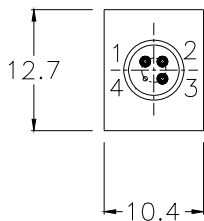
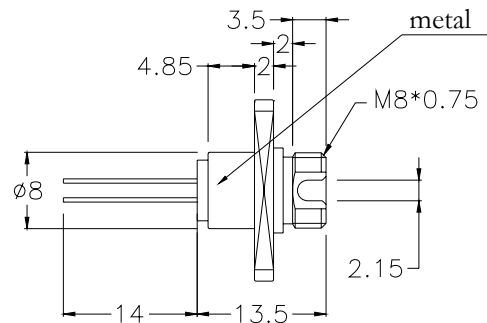

ST Receptacle
T-11-1250-R3-XST-XX

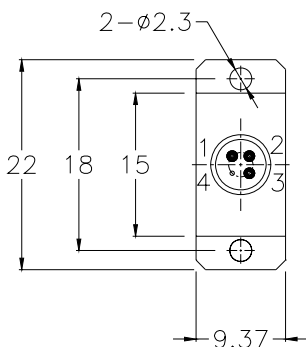
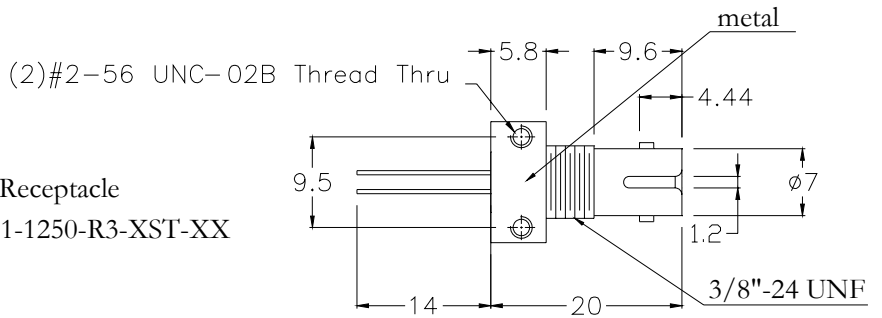

SC Receptacle
T-11-1250-R3-XSC-XX

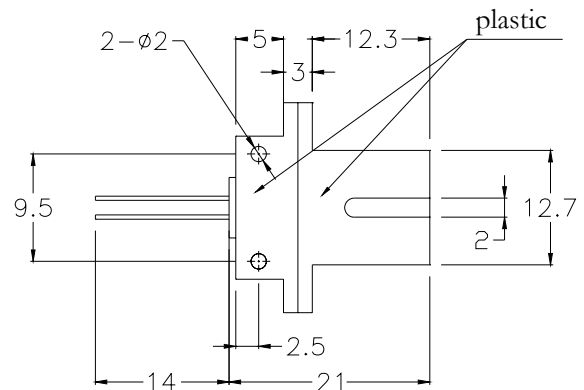

Mechanic Dimension (Units in mm)

Part Number: T-11-1250-P3-XXX-X-XX

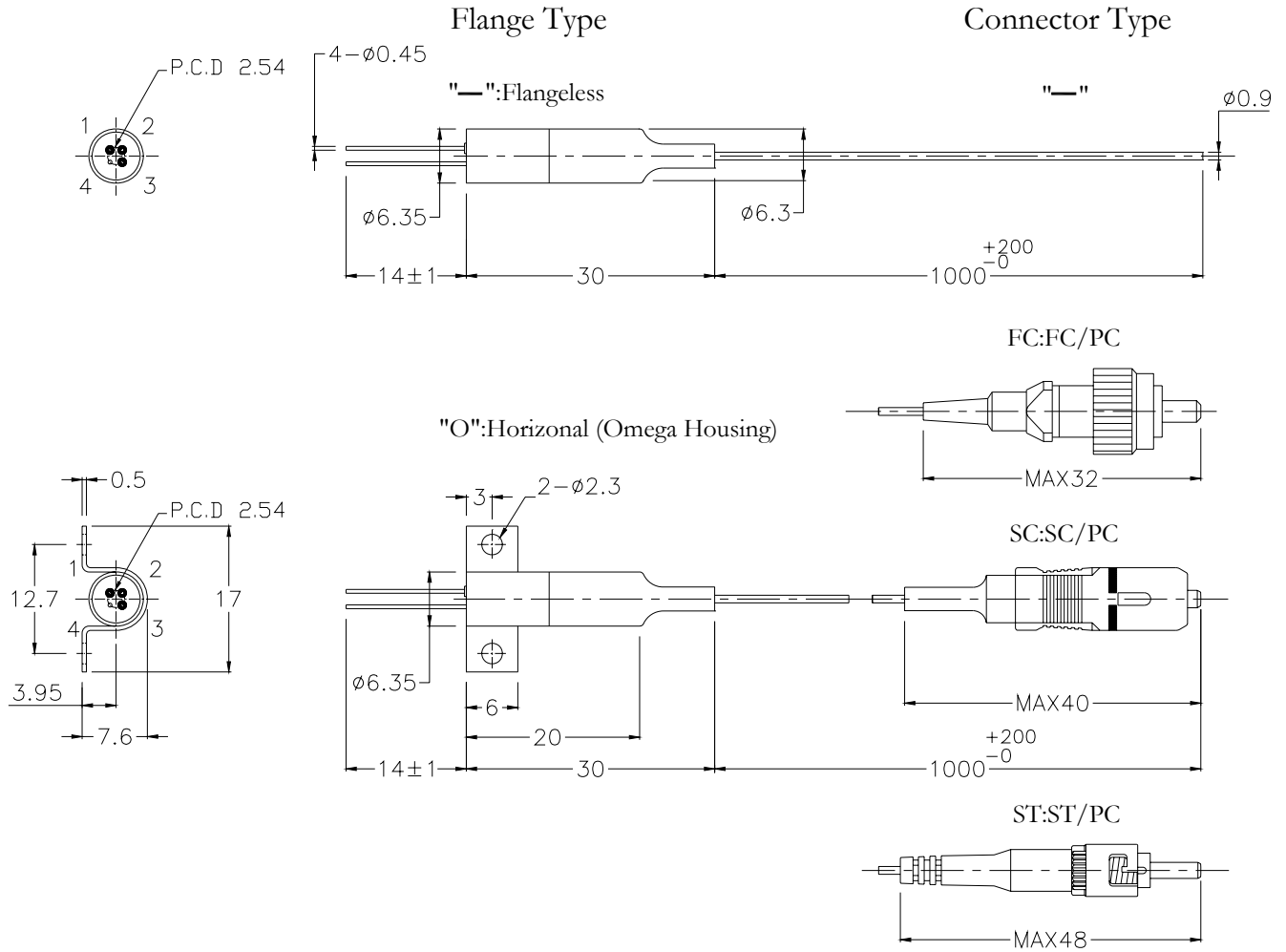

Ordering Information

T-11-1250-X3-XXX-X-XX

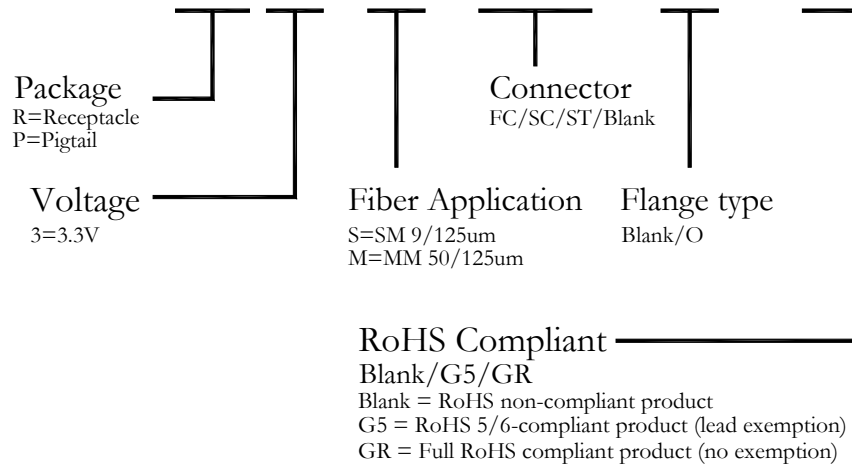

Warnings

Handling Precautions: This device is susceptible to damage as a result of electrostatic discharge (ESD). A static free environment is highly recommended. Follow guidelines according to proper ESD procedures.

Laser Safety: Radiation emitted by laser devices can be dangerous to human eyes. Avoid eye exposure to direct or indirect radiation.

Legal Notice

IMPORTANT NOTICE!

All information contained in this document is subject to change without notice, at Source Photonics's sole and absolute discretion. Source Photonics warrants performance of its products to current specifications only in accordance with the company's standard one-year warranty; however, specifications designated as "preliminary" are given to describe components only, and Source Photonics expressly disclaims any and all warranties for said products, including express, implied, and statutory warranties, warranties of merchantability, fitness for a particular purpose, and non-infringement of proprietary rights. Please refer to the company's Terms and Conditions of Sale for further warranty information.

Source Photonics assumes no liability for applications assistance, customer product design, software performance, or infringement of patents, services, or intellectual property described herein. No license, either express or implied, is granted under any patent right, copyright, or intellectual property right, and Source Photonics makes no representations or warranties that the product(s) described herein are free from patent, copyright, or intellectual property rights. Products described in this document are NOT intended for use in implantation or other life support applications where malfunction may result in injury or death to persons. Source Photonics customers using or selling products for use in such applications do so at their own risk and agree to fully defend and indemnify Source Photonics for any damages resulting from such use or sale.

THE INFORMATION CONTAINED IN THIS DOCUMENT IS PROVIDED ON AN "AS IS" BASIS. Customer agrees that Source Photonics is not liable for any actual, consequential, exemplary, or other damages arising directly or indirectly from any use of the information contained in this document. Customer must contact Source Photonics to obtain the latest version of this publication to verify, before placing any order, that the information contained herein is current.

© Copyright Source Photonics, Inc. 2010

All rights reserved