

OCXO (Oven Controlled Crystal Oscillators) +5.0 V; +12 V
OC30E Series 50 ohm Load Sine Wave

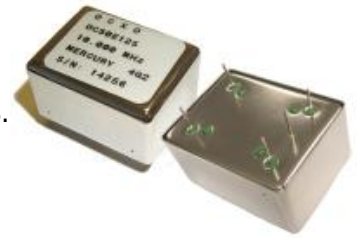

MERCURY
Since 1973

Mercury OC30E is 36.2x27.2 mm 5 pin solder sealed metal package with 25.4x17.8 mm pin-to-pin spacing high stability low aging OCXO. Besides standard AT cut crystal, users can also choose SC cut crystal for better performance. HCMOS square wave output is available as OC30T series. For same package size but with standard Eurocase OCXO pin configurations, please refer to OC31E series.



General Specifications (10 MHz at +25°C, at specified Vcc and +2.5 V Vcon)

| | | | | | | |
|--|---|--|--------------|---|----------------|----------|
| Output Wave Form | | Sine wave. Wave form code is "E" | | | | |
| Frequency Range | | 10 MHz ~100.0 MHz | | | | |
| Type of Crystal Cut Used | | AT-cut. Use "A" for crystal code or SC-cut: use "S" for crystal code. SC has better performance but higher cost. See technical note TN-031. | | | | |
| Supply Voltage (Vcc) | | +5.0 V _{D.C} ±5% (voltage code is "5"); +12.0 V _{D.C} ±5% (voltage code is "12") | | | | |
| Initial Calibration Tolerance | | ±0.5 ppm max. at time of shipment; Vcon = +2.5V | | | | |
| Frequency Stability vs | Operating Temperature Range (custom spec. on request) | Best Stability | 0°C to +60°C | -20°C to +70°C | -40°C to +85°C | |
| | | For AT crystal | ±0.03 ppm | ±0.08 ppm | ±0.2 ppm | |
| | | For SC crystal | ±0.01 ppm | ±0.02 ppm | ±0.03 ppm | |
| | Aging (after 72 hours of continuous operation) | AT: ±3 ppb max./day; ±0.5 ppm max./first year; ±3 ppm max. over 10 years. SC: ±2 ppb max./day; ±0.1 ppm max./first year; ±0.5 ppm max. over 10 years. | | | | |
| | Supply Voltage ±5% Variation | ±20 ppb max. | | | | |
| Load ±5% variation | ±20 ppb max. | | | | | |
| Warm-up time (at +25°C) | AT: 3 minutes max. Within ±0.5 ppm of its reference frequency. SC: 1 minute max. Within ±0.1 ppm of its reference frequency. | | | | | |
| Voltage Control on pin 1 (EFC) (Electronics Frequency Tuning) | Freq. Deviation Range | AT: ±5 ppm min. ±20 ppm max.; SC: ±0.5 ppm min, ±2 ppm max. | | Referenced to fo at +25°C and over operating temperature range. | | |
| | Control Voltage Range | 2.5 V ± 2.0 V | | | | |
| | Transfer Function | Positive: Increasing control voltage increases output frequency. | | | | |
| | Input Impedance | 100 K ohms min. | | | | |
| | EFC Linearity | ±10% max. | | | | |
| Power | Power Dissipation (at +25°C) | 1.2 Watts max. at steady-state; 3.5 Watts max. at turn-on. | | | | |
| Output | Output Level | +3 dBm typical; +8 dBm max. with 50Ω load | | | | |
| | Harmonic | -30 dBc min. | | | | |
| | Spurious | -75 dBc min. | | | | |
| | Reference Voltage | +4.0 V _{D.C.} ±0.3 V _{D.C.} or custom. | | | | |
| | Phase Noise | Offset | 1 Hz | 10 Hz | 100 Hz | 1 KHz |
| 10 MHz AT-cut XTAL | | -75 dBc | -100 dBc | -130 dBc | -140 dBc | -150 dBc |
| 10 MHz SC-cut XTAL | | -85 dBc | -120 dBc | -140 dBc | -145 dBc | -150 dBc |
| Storage Temperature | | -55°C to +125°C | | | | |
| Shock | | 2000 G's, 0.3 ms ½ sine | | | | |
| Vibration | | 10 to 2000 Hz / 10 G's | | | | |

MERCURY www.mercury-crystal.com

Taiwan: TEL (886)-2-2406-2779, FAX (886)-2-2496-0769, e-mail: sales-tw@mercury-crystal.com

U.S.A.: TEL (1)-909-466-0427, FAX (1)-909-466-0762, e-mail: sales-us@mercury-crystal.com

OC30E Test Circuit

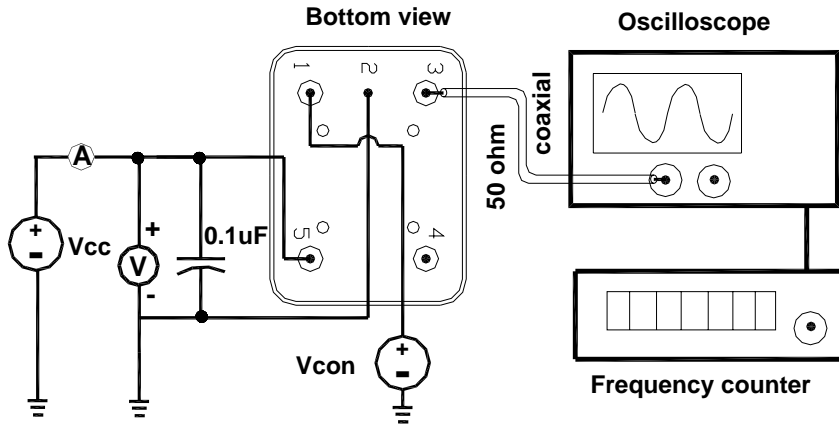

OC30E Series Package Dimensions and Pin Connections:

Pin 1: Voltage Control EFC Pin 2: Ground, Case
 Pin 4: Reference Voltage Output Pin 5: Supply Voltage

unit mm
 Pin 3: RF Output

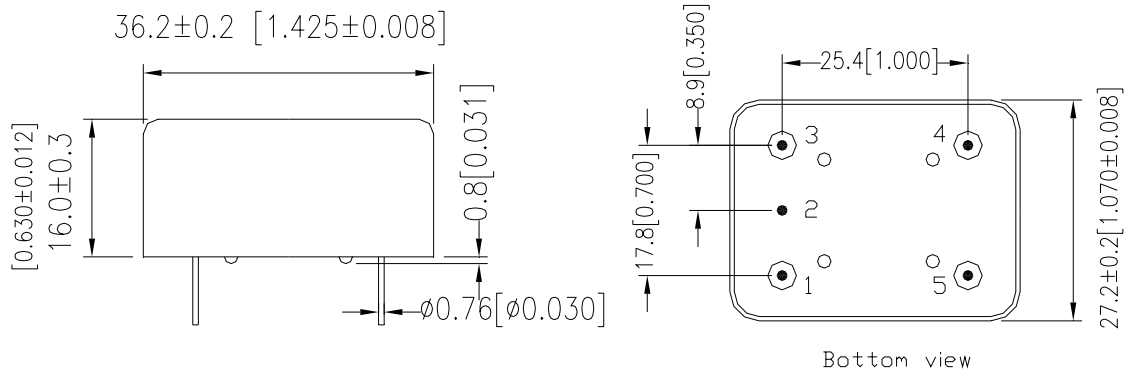

Part Number Format and Example:

| | | | | | | | | | | |
|--|----|---|---|---|------|--------|------|------|-------|--------|
| Example: OC30E5S-10.000-0.01/-20+70 | | | | | | | | | | |
| OC | 30 | E | 5 | S | — | 10.000 | — | 0.01 | / | -20+70 |
| ① | ② | ③ | ④ | ⑤ | dash | ⑥ | dash | ⑦ | slash | ⑧ |
| <p>①: "OC" Product Prefix for OCXO ②: Package type. "30" for OC30 package ③: Output wave form code. "E" for 50 ohm load Sine wave. ④: Supply voltage code. "5" for +5.0V; "12" for +12.0V ⑤: Crystal type. Use "A" for AT-cut crystal; Use "S" for SC-cut crystal. ⑥: Frequency in MHz; ⑦: Frequency stability in ppm; ⑧: Operating temperature range: -20°C to +70°C in this case.</p> | | | | | | | | | | |