

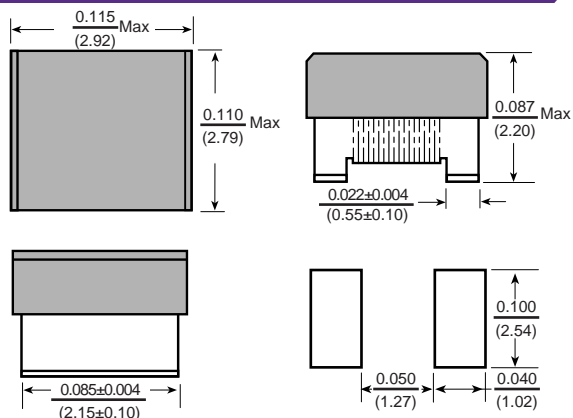

Ceramic Core Chip Inductors CC10



Dimensions: $\frac{\text{Inches}}{\text{(mm)}}$



Allied Part Number	Inductance (nh)	Tolerance (%) *	Test Freq.	Q Min.	Test Freq. (MHz)	SRF Min. (MHz)	DCR Max. (Ω)	Rated Current (mA)
CC10-10N_-RC	10	G,J,K	50	50	500	4100	0.08	1000
CC10-12N_-RC	12	G,J,K	50	50	500	3300	0.09	1000
CC10-15N_-RC	15	G,J,K	50	50	500	2500	0.18	1000
CC10-18N_-RC	18	G,J,K	50	50	350	2500	0.11	1000
CC10-22N_-RC	22	G,J,K	50	55	350	2400	0.12	1000
CC10-27N_-RC	27	G,J,K	50	55	350	1600	0.13	1000
CC10-33N_-RC	33	G,F,K	50	60	350	1600	0.14	1000
CC10-39N_-RC	39	G,F,K	50	60	350	1500	0.15	1000
CC10-47N_-RC	47	G,F,K	50	65	350	1500	0.16	1000
CC10-56N_-RC	56	G,F,K	50	65	350	1300	0.18	1000
CC10-68N_-RC	68	G,F,K	50	65	350	1300	0.20	1000
CC10-82N_-RC	82	G,F,K	50	60	350	1000	0.22	1000
CC10-100N_-RC	100	G,F,K	25	60	350	1000	0.56	650
CC10-120N_-RC	120	G,F,K	25	60	350	950	0.63	650
CC10-150N_-RC	150	G,F,K	25	45	100	850	0.70	580
CC10-180N_-RC	180	G,F,K	25	45	100	750	0.77	620
CC10-220N_-RC	220	G,F,K	25	45	100	700	0.84	500
CC10-270N_-RC	270	G,F,K	25	45	100	600	0.91	500
CC10-330N_-RC	330	G,F,K	25	45	100	570	1.05	450
CC10-390N_-RC	390	G,F,K	25	45	100	500	1.12	470
CC10-470N_-RC	470	G,F,K	25	45	100	450	1.19	470
CC10-560N_-RC	560	G,F,K	25	45	100	415	1.33	400
CC10-620N_-RC	620	G,F,K	25	45	100	375	1.40	300
CC10-680N_-RC	680	G,F,K	25	45	100	375	1.47	400
CC10-750N_-RC	750	G,F,K	25	45	100	360	1.54	360
CC10-820N_-RC	820	G,F,K	25	45	100	350	1.61	400
CC10-910N_-RC	910	G,F,K	25	35	50	320	1.68	380
CC10-1000N_-RC	1000	G,F,K	25	35	50	290	1.75	370
CC10-1200N_-RC	1200	G,F,K	7.9	35	50	250	2.00	310
CC10-1500N_-RC	1500	G,F,K	7.9	28	50	200	2.23	330
CC10-1800N_-RC	1800	G,F,K	7.9	28	50	160	2.60	300
CC10-2200N_-RC	2200	G,F,K	7.9	28	50	160	2.80	280
CC10-2700N_-RC	2700	G,F,K	7.9	22	25	140	3.20	290
CC10-3300N_-RC	3300	G,F,K	7.9	22	25	110	3.40	290
CC10-3900N_-RC	3900	G,F,K	7.9	20	25	100	3.60	260
CC10-4700N_-RC	4700	G,F,K	7.9	18	7.9	32	4.00	200
CC10-5600N_-RC	5600	G,F,K	7.9	18	7.9	45	4.00	200
CC10-6800N_-RC	6800	G,F,K	7.9	18	7.9	40	4.90	200
CC10-8200N_-RC	8200	G,F,K	7.9	18	7.9	25	6.00	170
CC10-10000N_-RC	10000	G,F,K	2.52	18	7.9	25	8.00	150

*Insert letter for desired tolerance. G= \pm 2%, J= \pm 5%, K= \pm 10%
All specifications subject to change without notice.

Features

- 1008 size suitable for pick and place automation
- Low Profile under 2.20mm
- Ceramic core provide high self resonant frequency.
- High Q values at high frequencies
- Ceramic core also provides excellent thermal and batch consistency

Electrical

Inductance Range: 10nH to 10,000nH
Tolerance: Available as noted. Insert letter for desired tolerance.
Test Frequency: At specified frequency
Operating Temp: -40°C ~ 125°C
Rated Current: The current at which the inductance shall change no more than 20% of initial value.

Resistance to Soldering Heat

Test Method: Reflow Solder the device onto PCB
 Peak Temp: 260°C \pm 5°C for 10 sec.
 Inductance: Within \pm 10% of initial value
 Q: Shall not exceed specification
 RDC: Within 15% of initial value and shall not exceed specifications

Test Equipment

(L/Q): Agilent 4291, 4287, E4991
(SRF): Agilent 4291, E4991
(RDC): Agilent 4338
Irms: HP4284A + HP42841A+/HP4285A+ HP42841A

Physical

Packaging: 2000 pieces per 7 inch reel.
Marking: None