



Product Specification

AHA3520

20 MBytes/sec ALDC Data Compression Coprocessor IC

*Advanced Hardware
Architectures, Inc.
2365 NE Hopkins Court
Pullman, WA 99163-5601
509.334.1000
Fax: 509.334.9000
e-mail: sales@aha.com
<http://www.aha.com>*

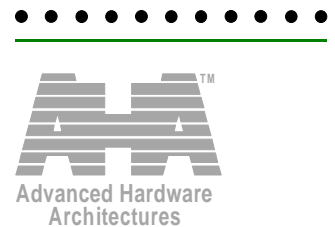

Table of Contents

1.0	Introduction	1
1.1	Conventions, Notations and Definitions	1
1.2	Features	1
1.3	Applications	1
1.4	Functional Description	1
1.4.1	Port A and Port B Interfaces	2
1.4.2	FIFO Operation	2
1.4.3	Data Expansion During Compression	2
2.0	Compression Operation	3
2.1	Compression Pass Through	3
2.2	Compression	3
3.0	Decompression Operation	4
3.1	Decompression Pass Through	4
3.2	Decompression	4
3.3	Decompression Output Disabled Mode	4
4.0	Microprocessor Interface and Register Access	4
4.1	Microprocessor Interface	4
4.1.1	Interrupts	4
4.1.2	Resets	5
4.2	Register Access	5
4.3	Pausing	5
5.0	Port A and Port B Configuration	5
6.0	Register Description	6
6.1	Status 0 (STAT0)	7
6.2	Port A Configuration 0 (ACNF0)	7
6.3	Port A Configuration 1 (ACNF1)	8
6.4	Port B Configuration 0 (BCNF0)	8
6.5	Port B Configuration 1 (BCNF1)	9
6.6	Identification (ID)	9
6.7	Port A Polarity (APOL)	9
6.8	Port B Polarity (BPOL)	10
6.9	Port A Transfer Count (ATC0, ATC1, ATC2, ATC3)	10
6.10	Port B Transfer Count (BTC0, BTC1, BTC2, BTC3)	10
6.11	Error Status (ERRS)	11
6.12	Interrupt Status (INTS)	11
6.13	Command (CMND)	12
6.14	Transfer Size (TS0, TS1, TS2, TS3)	13
6.15	Data Disabled Count (DDC0, DDC1, DDC2, DDC3)	13
6.16	error mask (EMSK)	14
6.17	Interrupt Mask (IMSK)	14
7.0	Signal Descriptions	15
7.1	Microprocessor Interface	15
7.2	Port A Interface	16
7.3	Port B Interface	17
8.0	Pinout	18
9.0	Electrical Specifications	20
9.1	Absolute Maximum Ratings	20
9.2	Recommended Operating Conditions	20
9.3	DC Specifications	20

10.0 Timing Specifications 21

11.0 Packaging 34

12.0 Ordering Information 35

 12.1 Available Parts 35

 12.2 Part Numbering 35

13.0 AHA Related Technical Publications 35

Figures

Figure 1:	Functional Block Diagram	3
Figure 2:	Pinout	19
Figure 3:	Clock Timing	21
Figure 4:	Reset Timing	21
Figure 5:	Almost Full/Almost Empty Timing	21
Figure 6:	Processor Read Timing, MMODE = 1	22
Figure 7:	Processor Write Timing, MMODE = 1	23
Figure 8:	Processor Read Timing, MMODE = 0	24
Figure 9:	Processor Write Timing, MMODE = 0	25
Figure 10:	Port A/B Timing, Four Edge, Master Mode	26
Figure 11:	Port A/B Timing, Four Edge, Slave Mode	27
Figure 12:	Port A/B Timing, Burst, Master Mode	28
Figure 13:	Port A/B Timing, Burst, Slave Mode	29
Figure 14:	Peripheral Access Read Timing, MMODE = 1	30
Figure 15:	Peripheral Access Write Timing, MMODE = 1	31
Figure 16:	Peripheral Access Read Timing, MMODE = 0	32
Figure 17:	Peripheral Access Write Timing, MMODE = 0	33
Figure 18:	AHA3520 PQFP Package Specifications	34

Tables

Table 1:	<i>Microprocessor Interface Control Signals</i>	4
Table 2:	<i>Port A Interface Signals</i>	5
Table 3:	<i>Port B Interface Signals</i>	5
Table 4:	<i>Clock Timing</i>	21
Table 5:	<i>Reset Timing</i>	21
Table 6:	<i>Almost Full/Almost Empty Timing</i>	21
Table 7:	<i>Processor Read Timing, MMODE = 1</i>	22
Table 8:	<i>Processor Write Timing, MMODE = 1</i>	23
Table 9:	<i>Processor Read Timing, MMODE = 0</i>	24
Table 10:	<i>Processor Write Timing, MMODE = 0</i>	25
Table 11:	<i>Port A/B Timing, Four Edge, Master Mode</i>	26
Table 12:	<i>Port A/B Timing, Four Edge, Slave Mode</i>	27
Table 13:	<i>Port A/B Timing, Burst, Master Mode</i>	28
Table 14:	<i>Port A/B Timing, Burst, Slave Mode</i>	29
Table 15:	<i>Peripheral Access Read Timing, MMODE = 1</i>	30
Table 16:	<i>Peripheral Access Write Timing, MMODE = 1</i>	31
Table 17:	<i>Peripheral Access Read Timing, MMODE = 0</i>	32
Table 18:	<i>Peripheral Access Write Timing, MMODE = 0</i>	33
Table 19:	<i>PQFP (Plastic Quad Flat Pack) 14 mm x 20 mm Package Dimensions</i>	34

1.0 INTRODUCTION

AHA3520 is a single chip lossless compression and decompression integrated circuit implementing the industry standard adaptive lossless data compression algorithm, also known as ALDC. The device compresses, decompresses or passes through data unchanged depending on the operating mode selected. This device achieves an average compression ratio of 2:1 on typical computer files. The flexible hardware interface makes this part suitable for many applications.

AHA 3520 is algorithm and pinout compatible to the IBM ALDC device. Compressed files between AHA and IBM's implementation of the algorithm do not always produce the same compressed code stream. However, the decompressed results are always the same. Files compressed on either device can be interchanged and decompressed on either device.

Content Addressable Memory (CAM) within the compression/decompression engine eliminates the need for external SRAMS. This part connects directly to industry standard peripheral chips.

Included in this specification is a functional overview, operation modes, register descriptions, DC and AC Electrical characteristics, ordering information, and a listing of related technical publications. It is intended for hardware and software engineers designing a compression system using AHA3520.

AHA designs and develops lossless compression, forward error correction and data storage formatter/controller ICs. Other ALDC product offering includes AHA3521. This is a pin and firmware compatible device that includes additional features. Technical publications are available upon request.

1.1 CONVENTIONS, NOTATIONS AND DEFINITIONS

- Active low signals have an "N" appended to the end of the signal name. For example, CSN and WRITEN.
- "Signal assertion" means the output signal is logically true.
- Hex values are represented with a prefix of "0x", such as Register "0x00". Binary values do not contain a prefix, for example, MMODE = 1.
- A prefix or suffix of "x" indicates a letter missing in a register name or signal name. For example, xCNF0 refers to the ACNF0 or BCNF0 register.
- A range of signal names or register bits is denoted by a set of colons between the numbers. Most significant bit is always shown first, followed by

least significant bit. For example, MDATA[7:0] indicates signal names MDATA7 through MDATA0.

- Mega Bytes per second is referred to as MBytes/sec or MB/sec.
- Reserved bits in registers are referred as "res".

1.2 FEATURES

PERFORMANCE:

- 20 MB/s data compression, decompression or pass-through rate with a single 40 MHz clock
- 2:1 average compression ratio
- A four byte *Transfer Size* register allows block transfers up to 4 gigabytes
- Error checking in decompression mode reportable via an interrupt

FLEXIBILITY:

- In-line and Look-aside architectures supported
- Polled or interrupt driven I/O
- Two independent DMA ports programmable for 8 or 16-bit transfers, handshaking modes and master or slave operation
- Programmable polarity for DMA control signals

SYSTEM INTERFACE:

- Single chip data compression solution
- Two selectable microprocessor interfaces
- Programmable Interrupts
- Interfaces directly with the AHA5140 tape formatter and industry standard SCSI chips

OTHERS:

- Open standard ALDC adaptive lossless compression algorithm
- Complies to QIC-154, ECMA 222, ANSI X3.280-1996 and ISO 15200 standard specifications
- Compatible to IBM ALDC1-20S-HA specification
- 100 pin package in 14 × 20 mm PQFP

1.3 APPLICATIONS

- QIC or 8 mm tape drives

1.4 FUNCTIONAL DESCRIPTION

AHA3520 is a compression/decompression device residing between the host interface, usually SCSI, and the buffer manager ASIC. Major blocks in this device are the Microprocessor Interface, Port A Interface, Port B Interface, and the Compression/Decompression Engine. The Microprocessor Interface provides status and control information by register access. Port A and Port B Interfaces are DMA ports configurable for bus width, polarity, handshaking modes, and other options. The

operating mode establishes the direction of both the Port A and Port B Interfaces. Compression or Compression Pass Through sets the Port A Interface as an input and the Port B Interface as an output. Conversely Decompression or Decompression Pass Through sets the Port A Interface as an output and the Port B Interface as an input. Decompression Output Disabled mode allows the device to decompress a block of data up to a predetermined point while dumping the uncompressed data, then automatically begin outputting the remaining uncompressed data in that block or record.

A four byte Transfer Size counter allows the user to partition the data into blocks of four gigabytes or less to process. Compression Pass Through mode and Decompression Pass Through modes allow data transfers through the device without changing the data. Both the Port A Interface and Port B Interface have a 16-byte FIFO with Almost Empty and Almost Full signal pins and programmable thresholds. Both DMA interfaces, Port A and Port B, have programmable wait states in addition to four selectable DMA transfer modes: asynchronous request/acknowledge pair, asynchronous burst mode, and two peripheral access modes that correlate with the two microprocessor modes.

1.4.1 PORT A AND PORT B INTERFACES

Both Port A and Port B Interfaces are independently configurable via the *Port A Configuration* registers (ACNFx), the *Port A Polarity* register (APOL), the *Port B Configuration* registers (BCNFx), and the *Port B Polarity* register (BPOL). Both operate in four DMA modes.

Four-edge mode is an asynchronous data transfer requiring a request and acknowledge pulse for each transfer of one or two bytes, depending on the width configuration of the Interface. A four edge transfer begins by asserting the request signal, followed by the acknowledge in response to the request, which causes the request to deassert, and finally this causes the acknowledge to deassert. Data is transferred on the trailing edge of the acknowledge signal.

Burst mode is similar to four-edge mode except there may be many acknowledges while the request is held asserted. The advantage of this mode is that it requires fewer clocks per transfer.

Two peripheral access modes exist and are selected via the MMODE pin. Peripheral access allows the microprocessor to write to and read from a peripheral device connected to the Port A Interface or Port B Interface. This mode is a relatively slow, asynchronous transfer. This mode is not allowed during a data transfer operation.

1.4.2 FIFO OPERATION

Port A and Port B Interfaces both contain sixteen-byte FIFOs with programmable thresholds. AHA3520 has an Almost Full and an Almost Empty signal pin associated with each of the Data Interfaces. The FIFO thresholds are programmed in the configuration registers (ACNF0 and BCNF0). If the Data Interface is configured for either four-edge or burst mode of operation the FIFO threshold determines when request gets asserted and deasserted. During an output transfer the request signal asserts when the number of bytes in the FIFO is greater than or equal to the programmed FIFO threshold. The interface continues to request data transfers until the FIFO becomes empty.

When transferring data into either the Port A or Port B Interfaces, the request signal asserts when the number of empty byte locations in the FIFO is greater than or equal to the programmed FIFO threshold. The interface continues to request data transfers until the FIFO is full.

The almost full (xAF) and almost empty (xAE) signals are always available to the user. Almost Full can be used as an early warning indicator to stop transferring data into the Port B Interface or Port A Interface. The xAE signal can be used to stop transfers out of the Port A Interface or Port B Interface

The xAF signal deasserts when a transfer operation begins. It asserts the clock after the number of empty byte locations in the FIFO is less than or equal to the FIFO threshold. The xAF signal deasserts the clock after the number of empty byte locations in the FIFO is greater than the FIFO threshold.

The xAE signal asserts when a transfer operation begins. It deasserts the clock after the number of available bytes in the FIFO is greater than the FIFO threshold. The xAE signal asserts after the clock when the number of available bytes in the FIFO is less than or equal to the FIFO threshold.

1.4.3 DATA EXPANSION DURING COMPRESSION

Data expansion occurs when the size of the data increases during a compression operation. This typically occurs when the data is compressed prior to input into the chip. The EXPAND status bit is set if the Port B Transfer Count is larger than the *Transfer Size* register. If data expansion caused the Port B Transfer Count to exceed its maximum 4-byte value then the BTC Overflow Error status gets set. Worst case expansion allowable by the algorithm is 12.5% or (9/8 times the uncompressed transfer size).

Figure 1: Functional Block Diagram

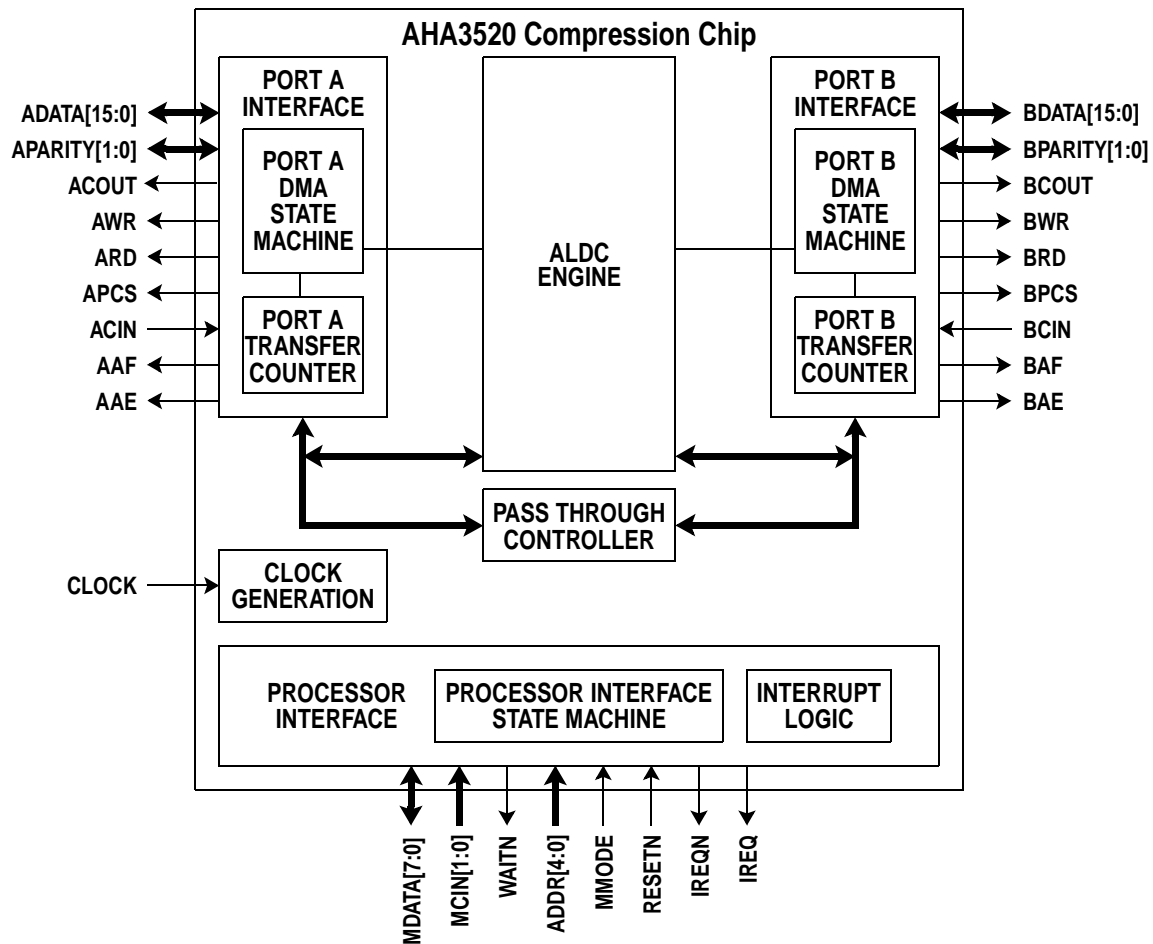

2.0 COMPRESSION OPERATION

2.1 COMPRESSION PASS THROUGH

Compression Pass Through mode allows data to enter the Port A Interface, transfer through the device unchanged and exit through the Port B Interface. Pass through mode uses the Port A Transfer counter, Port B Transfer counter and *Transfer Size* register. The DONE status bit and interrupt (if not masked) are set when the transfer completes.

2.2 COMPRESSION

During compression operation, uncompressed data flows into the Port A Interface, is compressed by the compression engine and the compressed data transferred out of the Port B Interface.

The device contains a Content Addressable Memory (CAM). The CAM is the history buffer during compression operation. The compressor appends an end marker control code to the end of the compressed data. It also pads the end of a transfer to a byte boundary with zeroes. End marker control

codewords are monitored during decompression, to determine Decompression End errors.

The compression engine constantly monitors the performance of compression for expansion during compression operation. The EXPAND bit is set if the Port B Transfer Count is larger than the transfer size at the end of a compression operation. When the Port B Transfer Count is higher than the Port A Transfer Count the EXPAND bit in the *Status 0* register is set indicating data expansion during compression operation.

Port A Interface count increments with each byte received and when this count equals the transfer size, all bytes in this transfer have been received into Port A.

A compression operation is complete when the last byte transfers out of the Port B Interface and the Port B Interface count is zero, thus setting the DONE status bit and generating a Done Interrupt if it is not masked.

3.0 DECOMPRESSION OPERATION

3.1 DECOMPRESSION PASS THROUGH

Decompression Pass Through mode allows data to enter the Port B Interface, transfer through the device unchanged and exit through the Port A Interface. Pass through mode uses the Port A Transfer counter, Port B Transfer counter and *Transfer Size* register. The DONE status bit and interrupt (if not masked) are set when the transfer completes.

3.2 DECOMPRESSION

During Decompression mode, compressed data flows into the Port B Interface and is decompressed. The resulting uncompressed data is transferred out of the Port A Interface.

The number of compressed bytes in the transfer is programmed into the four byte *Transfer Size* register. A decompression operation is complete when the last byte transfers out of the Port A Interface, thus setting the DONE status bit and generating a Done Interrupt if it is not masked.

Two types of errors are detected and reported during decompression. Decoder Control Codes Errors are caused by detection of invalid control codes in the compressed data stream. Decoder End Errors are detected when either the decompressor encountered an end control code before the expected end of record indicated by the *Transfer Size* register, or the end of record was reached according to the *Transfer Size* register but no end control code was detected. These errors are reported in the *Error Status* register.

3.3 DECOMPRESSION OUTPUT DISABLED MODE

Decompressed output disabled mode allows the user to decompress to a point in the record or block and rebuild the history buffer while discarding the uncompressed data. After the point in the file is

reached where the user wants the data (Port A Transfer Count is equal or greater than the Data Disable Count), the device switches to normal decompression mode and the remainder of that file is decompressed and transferred out of the Port A Interface. Removal of CBG headers also applies to this mode.

4.0 MICROPROCESSOR INTERFACE AND REGISTER ACCESS

4.1 MICROPROCESSOR INTERFACE

Microprocessor Interface configuration is determined by the MMODE pin. If MMODE is tied high transfers are controlled by a chip select signal (CSN) and a read/write signal (RWN), otherwise transfers are controlled by separate read (READN), write (WRITEN) signals. Refer to Section 10.0 *Timing Specifications* for timing diagrams.

4.1.1 INTERRUPTS

IREQ and IREQN are two hardware interrupt signals. IREQN is a negative active open-drain output that requires a pull-up resistor if it is used. IREQ is a standard TTL output. When active they indicate an interrupt is set in the device. The microprocessor can determine the cause of the interrupt by reading the *Interrupt Status* register.

Masking individual interrupts with the *Interrupt Mask* register disables particular interrupts from causing the interrupt signal pins to assert (IREQ and IREQN). They do not disable bits in the *Interrupt Status* register.

The interrupt signals are reset to their inactive state when either a hardware or software reset occurs, when a data transfer operation resumes, or when a data transfer operation begins. In addition, disabling Interrupt Mask bits after the Interrupt pin is asserted, clears the interrupt and deasserts the Interrupt pin.

Table 1: Microprocessor Interface Control Signals

PIN NAME	MMODE TIED LOW	MMODE TIED HIGH
MCIN[0]	READN	CSN
MCIN[1]	WRITEN	RWN
WAITN	WAITN	WAITN
ADDR[0]	ADDR[0] = 0 selects register bits 7:0 ADDR[0] = 1 selects register bits 15:8	ADDR[0] = 0 selects register bits 15:8 ADDR[0] = 1 selects register bits 7:0

4.1.2 RESETS

The AHA3520 has one hardware reset signal and a software reset. When the RESETN signal is asserted all registers except the *Identification* registers are reset, current operations are cancelled, and the history buffer is cleared. The software reset via the *Command* register does not affect the *Configuration* registers (ACNFx or BCNFx), *Identification* registers (IDx), either of the *Polarity* registers (APOL or BPOL), or the *Command* register (CMND). All other registers are reset, current operations cancelled and the history buffer cleared.

4.2 REGISTER ACCESS

MMODE determines whether ADDR[0] selects even or odd addressed registers. When MMODE is high and ADDR[0]=0, odd addressed registers are accessible. MMODE=1 causes ADDR[0] input signal to be inverted.

The following registers may not be stable if BUSY is set: *Status 0*, *Status 1*, *Port A Transfer Count*, *Port B Transfer Count*, *Error Status*, *Interrupt Status* and *FIFO Access*.

4.3 PAUSING

When a Pause command is issued, the device pauses at the next break in the DMA handshaking. When a port is in slave mode, it pauses after xCOUT (DACKx) deasserts. When a port is in master mode and xCOUT (DREQx) is asserted, the port does not pause until xCIN (DACKx) is received from the external DMA device. The AHA3520 waits until both ports are paused, at which time the BUSY status bit clears and the PAUSED status bit and interrupt are set.

5.0 PORT A AND PORT B CONFIGURATION

Port A and Port B operate identically. They both are 16-bit bidirectional data ports with parity checking and generation. There are three configuration registers associated with each port and a polarity register that determines the polarity of all of the control signals for that port.

The function of the control pin is determined by either xCNF0[13, 12] bits or *Command* register programmed for peripheral access. The polarity of control signals are controlled by specific bits in the *Polarity* registers.

Table 2: Port A Interface Signals

SIGNAL NAME	MASTER SLAVE=0	SLAVE SLAVE=1	APOL bit	DIRECTION
ACIN	DACKA	DREQA	7	I
ACOUT	DREQA	DACKA	5	O
AWR	deasserted	AWR	4	O
ARD	deasserted	ARD	3	O
APCS	APCS	APCS	2	O
AAF	AAF	AAF	1	O
AAE	AAE	AAE	0	O

Table 3: Port B Interface Signals

SIGNAL NAME	MASTER SLAVE=0	SLAVE SLAVE=1	BPOL bit	DIRECTION
BCIN	DACKB	DREQB	7	I
BCOUT	DREQB	DACKB	5	O
BWR	deasserted	BWR	4	O
BRD	deasserted	BRD	3	O
BPCS	BPCS	BPCS	2	O
BAF	BAF	BAF	1	O
BAE	BAE	BAE	0	O

6.0 REGISTER DESCRIPTION

ADDR[4:0]		MNEMONIC	REGISTER NAME	R/W	NOTES	REGISTER RESET VALUE		
MMODE=0	MMODE=1					HARDWARE RESET	RESET COMMAND	NEW TRANSFER COMMAND
0x00	0x01	STAT0	Status 0	R	1	0x00	0x00	0x80
0x01	0x00	<i>res</i>	<i>Reserved</i>					
0x00	0x01	ACNF0	Port A Configuration 0	R/W	2	0x00	unchanged	unchanged
0x01	0x00	ACNF1	Port A Configuration 1	R/W	2	0x00	unchanged	unchanged
0x00	0x01	BCNF0	Port B Configuration 0	R/W	3	0x00	unchanged	unchanged
0x01	0x00	BCNF1	Port B Configuration 1	R/W	3	0x00	unchanged	unchanged
0x02	0x03	ID	Identification	R	1	0xC1	0xC1	0xC1
0x03	0x02	<i>res</i>	<i>Reserved</i>					
0x02	0x03	APOL	Port A Polarity	R/W	2	0xFF	unchanged	unchanged
0x03	0x02	<i>res</i>	<i>Reserved</i>					
0x02	0x03	BPOL	Port B Polarity	R/W	3	0xFF	unchanged	unchanged
0x03	0x02	<i>res</i>	<i>Reserved</i>					
0x04	0x05	ATC2	Port A Transfer Count, Byte 2	R	4	0x00	0x00	0x00
0x05	0x04	ATC3	Port A Transfer Count, Byte 3	R	4	0x00	0x00	0x00
0x06	0x07	ATC0	Port A Transfer Count, Byte 0	R	4	0x00	0x00	0x00
0x07	0x06	ATC1	Port A Transfer Count, Byte 1	R	4	0x00	0x00	0x00
0x08	0x09	BTC2	Port B Transfer Count, Byte 2	R	5	0x00	0x00	0x00
0x09	0x08	BTC3	Port B Transfer Count, Byte 3	R	5	0x00	0x00	0x00
0x0A	0x0B	BTC0	Port B Transfer Count, Byte 0	R	5	0x00	0x00	0x00
0x0B	0x0A	BTC1	Port B Transfer Count, Byte 1	R	5	0x00	0x00	0x00
0x0C	0x0D	ERRS	Error Status	R	1	0x00	0x00	0x00
0x0D	0x0C	<i>res</i>	<i>Reserved</i>		1			
0x0E	0x0F	INTS	Interrupt Status	R	1	0x00	0x00	0x00
0x0F	0x0E	<i>res</i>	<i>Reserved</i>					
0x10	0x11	<i>res</i>	<i>Reserved</i>					
0x11	0x10	CMND	Command	R/W		0x00	0x00	0x00
0x12	0x13	<i>res</i>	<i>Reserved</i>					
0x13	0x12	<i>res</i>	<i>Reserved</i>					
0x14	0x15	TS2	Transfer Size, Byte 2	R/W		0x00	0x00	unchanged
0x15	0x14	TS3	Transfer Size, Byte 3	R/W		0x00	0x00	unchanged
0x16	0x17	TS0	Transfer Size, Byte 0	R/W		0x00	0x00	unchanged
0x17	0x16	TS1	Transfer Size, Byte 1	R/W		0x00	0x00	unchanged
0x18	0x19	DDC2	Data Disabled Count, Byte 2	R/W		0x00	0x00	unchanged
0x19	0x18	DDC3	Data Disabled Count, Byte 3	R/W		0x00	0x00	unchanged
0x1A	0x1B	DDC0	Data Disabled Count, Byte 0	R/W		0x00	0x00	unchanged
0x1B	0x1A	DDC1	Data Disabled Count, Byte 1	R/W		0x00	0x00	unchanged
0x1C	0x1D	EMSK	Error Mask	R/W		0x00	0x00	unchanged
0x1D	0x1C	<i>res</i>	<i>Reserved</i>					
0x1E	0x1F	IMSK	Interrupt Mask	R/W		0x00	0x00	unchanged
0x1F	0x1E	<i>res</i>	<i>Reserved</i>					

Notes:

- 1) When CMND is not a Selection Command.
- 2) When CMND is a Select Port A Configuration Command.
- 3) When CMND is a Select Port B Configuration Command.
- 4) When CMND is any Transfer Command or Select Port A Configuration Command.
- 5) When CMND is any Transfer Command or Select Port B Configuration Command.

6.1 STATUS 0 (STAT0)

Read Only
 Reset Value = 0x00
 Software Reset Value = 0x00

<i>MMODE</i> =		<i>bit7</i>	<i>bit6</i>	<i>bit5</i>	<i>bit4</i>	<i>bit3</i>	<i>bit2</i>	<i>bit1</i>	<i>bit0</i>
0	1	BUSY	PAUSED	OUTDIS	BYPASS	EXPAND	ANYINT	ANYERR	DONE
0x00	0x01								

- BUSY** - Busy. This bit is set when a data transfer operation begins. It is cleared when the data transfer operation completes successfully, when an unmasked error occurs, when a reset occurs, or when a paused command is issued by the microprocessor.
- PAUSED** - Paused. This bit is set when a data transfer operation is currently paused. It is cleared when a paused data transfer operation is resumed or when a reset occurs.
- OUTDIS** - Output Disabled. This bit is set when Port A Interface output is disabled. It is cleared when Port A Interface output is re-enabled or when a reset occurs.
- BYPASS** - Bypass. This bit is set after a Start Compression Bypass or a Start Decompression Bypass command is written to the *Command* register. It is cleared after a Start Compression, Start Decompression or when a reset occurs.
- EXPAND** - Expansion. This bit is set when the *Port B Transfer Count* register is larger than the *Transfer Size* register at the end of a compression operation. It is cleared when another data transfer operation begins or when a reset occurs.
- ANYINT** - Any Interrupt. This bit is set while an unmasked interrupt is active. This signal mirrors the Interrupt signal pin.
- ANYERR** - Any Error. This bit is set when an unmasked error occurs. It is cleared when a data transfer operation begins or when a reset occurs.
- DONE** - Done. This bit is set when the current data transfer operation is complete. It is cleared when a data transfer operation begins or when a reset occurs.

6.2 PORT A CONFIGURATION 0 (ACNF0)

Read/Write
 Reset Value = 0x00
 Software Reset Value = unchanged

<i>MMODE</i> =		<i>bit7</i>	<i>bit6</i>	<i>bit5</i>	<i>bit4</i>	<i>bit3</i>	<i>bit2</i>	<i>bit1</i>	<i>bit0</i>
0	1	reserved	WAITST[2:0]			FIFOTH[3:0]			
0x00	0x01								

- WAITST[2:0]**-Wait State. These bits configure the number of wait states used during a Port A Interface peripheral access. The values 011 through 111 are valid.
- FIFOTH[3:0]**-FIFO Threshold. These bits configure the Port A FIFO threshold value. Values from 0000 through 1111 are valid.

6.3 PORT A CONFIGURATION 1 (ACNF1)

Read/Write
 Reset Value = 0x00
 Software Reset Value = unchanged

MMODE =

0	1	bit7	bit6	bit5	bit4	bit3	bit2	bit1	bit0
0x01	0x00	PARITY	ODD	SLAVE	MODE[1:0]		WIDE	reserved	

- PARITY** - Parity. When set, parity checking is enabled for the ADATA[15:0] data bus. When cleared, parity checking is disabled for the ADATA[15:0] bus.
- ODD** - Odd. Setting this bit along with PARITY enables odd parity checking and generation on the ADATA[15:0] data bus. When cleared with PARITY set even parity checking and generation is enabled on the ADATA[15:0] data bus.
- SLAVE** - Slave. When set, the Port B Interface acts as a slave device and generates acknowledges in response to requests. When cleared, the Port B Interface acts as a DMA master, and generates requests and expects acknowledges.
- MODE[1:0]**-DMA Mode. These bits configure the interface DMA mode of the Port A Interface with values as defined below.

MODE[1:0]	DMA TYPE
00	Four Edge
01	Burst
10	reserved
11	reserved

- WIDE** - Two Byte. When set, ADATA[15:0] and PARITY[1:0] are used. When cleared, AD[7:0] and PARITY[0] are used.

6.4 PORT B CONFIGURATION 0 (BCNF0)

Read/Write
 Reset Value = 0x00
 Software Reset Value = unchanged

MMODE =

0	1	bit7	bit6	bit5	bit4	bit3	bit2	bit1	bit0
0x00	0x01	reserved	WAITST[2:0]			FIFOTH[3:0]			

- WAITST[2:0]**-Wait State. These bits configure the number of wait states used during Port A Interface peripheral access. The values 001 through 111 are valid. Values 000, 001, 010 result in two wait states.
- FIFOTH[3:0]**-FIFO Threshold. These bits configure the Port A FIFO threshold value. Values from 0001 through 1111 are valid. A value of 0000 results in the same operation as 0001.

6.5 PORT B CONFIGURATION 1 (BCNF1)

Read/Write
 Reset Value = 0x00
 Software Reset Value = unchanged

MMODE =		bit7	bit6	bit5	bit4	bit3	bit2	bit1	bit0
0	1	PARITY	ODD	SLAVE	MODE[1:0]	WIDE	reserved		
0x01	0x00								

PARITY - Parity. When set, parity checking is enabled for the BDATA[15:0] data bus. When cleared, parity checking is disabled for the BDATA[15:0] bus.

ODD - Odd. When set, odd parity checking and generation is used on the BDATA[15:0] data bus. When cleared, even parity checking and generation is used on the BDATA[15:0] data bus.

SLAVE - Slave. When set, the Port B Interface acts as a slave device and generates acknowledges in response to requests. When cleared, the Port B Interface acts as a DMA master, and generates requests and expects acknowledges.

MODE[1:0]-DMA Mode. These bits configure the interface DMA mode of the Port B Interface with values as defined below.

MODE[1:0]	DMA TYPE
00	Four Edge
01	Burst
10	reserved
11	reserved

WIDE - Two Byte. When set, BDATA[15:0] and PARITY[1:0] are used. When cleared, BD[7:0] and PARITY[0] are used.

6.6 IDENTIFICATION (ID)

Read Only
 Value = Contact AHA Applications Engineering

MMODE =		bit7	bit6	bit5	bit4	bit3	bit2	bit1	bit0
0	1	ID[7:0]							
0x02	0x03								

ID[7:0]- The bits of this register correspond to the identification code of the chip. This register is accessible when CMND is not a Selection Command.

6.7 PORT A POLARITY (APOL)

Read/Write
 Reset Value = 0xFF
 Software Reset Value = unchanged

MMODE =		bit7	bit6	bit5	bit4	bit3	bit2	bit1	bit0
0	1	ACIN	reserved	ACOUT	AWR	ARD	APCS	AAF	AAE
0x02	0x03								

The bits of this register correspond to Port A Interface signals. A set bit programs the corresponding signal to be active low. A cleared bit programs the corresponding signal to be active high. This register is only accessible when CMND is Select Port A Configuration.

6.8 PORT B POLARITY (BPOL)

Read/Write

Reset Value = 0xFF

Software Reset Value = unchanged

MMODE =		bit7	bit6	bit5	bit4	bit3	bit2	bit1	bit0
0	1								
0x02	0x03	BCIN	reserved	BCOUT	BWR	BRD	BPCS	BAF	BAE

The bits of this register correspond to Port B Interface signals. A set bit programs the corresponding signal to be active low. A cleared bit programs the corresponding signal to be active high. This register is only accessible when CMND is Select Port B Configuration.

6.9 PORT A TRANSFER COUNT (ATC0, ATC1, ATC2, ATC3)

Read Only

Reset Value = 0x00

Software Reset Value = 0x00

MMODE =		bit7	bit6	bit5	bit4	bit3	bit2	bit1	bit0
0	1								
0x06	0x07	ATC[7:0]							
0x07	0x06	ATC[15:8]							
0x04	0x05	ATC[23:16]							
0x05	0x04	ATC[31:24]							

ATC[31:0]- Port A Transfer Count. These registers provide status information on the number of bytes transferred for a current data transfer operation. During a compression operation, ATC is incremented as each original data byte is received by the Port A Interface. When ATC equals TS during compression, all bytes in the compression operation have been received by the AHA3520. During a decompression operation, ATC is incremented as each decompressed data byte is sent by the Port A Interface. This register is only accessible when CMND is not a Selection Command.

6.10 PORT B TRANSFER COUNT (BTC0, BTC1, BTC2, BTC3)

Read Only

Reset Value = 0x00

Software Reset Value = 0x00

MMODE =		bit7	bit6	bit5	bit4	bit3	bit2	bit1	bit0
0	1								
0x00	0x01	BTC[7:0]							
0x01	0x00	BTC[15:8]							
0x00	0x01	BTC[23:16]							
0x01	0x00	BTC[31:24]							

BTC[31:0] -Port B Transfer Count. These registers provide status information on the number of bytes transferred for a current data transfer operation. During a compression operation, BTC is incremented as each compressed data byte is sent by the Port B Interface. During a decompression operation, BTC is incremented as each compressed data byte is received by the Port B Interface. When BTC equals TS during decompression, all bytes in the decompression operation have been received by the AHA3520 host interface. This register is only accessible when CMND is not a Selection Command.

6.11 ERROR STATUS (ERRS)

Read Only

Reset Value = 0x00

Software Reset Value = 0x00

MMODE =		bit7	bit6	bit5	bit4	bit3	bit2	bit1	bit0
0	1								
0x0C	0x0D	reserved	APERR	BPERR	reserved	BTCO	ATCO	ADCC	ADE

The *Error Status* register provides error status bits to the microprocessor. This register should only be read when CMND is not a Selection Command. These bits are set regardless of the error mask settings.

- APERR** - Port A Interface Parity Error. This bit is set when a parity error is detected during a transfer into ADATA[15:0] and the Port A Interface Parity bit is set. It is cleared when a data transfer operation begins or when a reset occurs.
- BPERR** - Port B Interface Parity Error. This bit is set when a parity error is detected during a transfer into BDATA[15:0] and the Port B Interface Parity bit is set. It is cleared when a data transfer operation begins or when a reset occurs.
- BTCO** - Port B Transfer Count Overflow Error. This bit is set when a carry out is detected on the *Port B Transfer Count* register. It is cleared when a data transfer operation begins or when a reset occurs.
- ATCO** - Port A Transfer Count Overflow Error. This bit is set when a carry out is detected on the *Port A Transfer Count* register. It is cleared when a data transfer operation begins or when a reset occurs.
- ADCC** - ALDC Decoder Control Code Error. This bit is set during decompression when an invalid control code is detected in the compressed data stream. It is cleared when a data transfer operation begins or when a reset occurs.
- ADE** - ALDC Decoder End Error. This bit is set during decompression when an End control code is detected while Port B Transfer Count is less than Transfer Size or when BTC equals TS and no End control code is detected in the compressed data stream. It is cleared when a data transfer operation begins or when a reset occurs.

6.12 INTERRUPT STATUS (INTS)

Read Only

Reset Value = 0x00

Software Reset Value = 0x00

MMODE =		bit7	bit6	bit5	bit4	bit3	bit2	bit1	bit0
0	1								
0x0E	0x0F	DONE	PAUSED	reserved				ERROR	

- DONE** - Done Interrupt. This bit is set when data transfer has completed on the Port B Interface during compression and when data transfer has completed on the Port A Interface during decompression. It is cleared when a data transfer operation begins or when a reset occurs.
- PAUSED** - Paused Interrupt. This bit is set when the current transfer step after the microprocessor issues a Pause command is completed. It is cleared when the microprocessor issues a Resume command, when a data transfer operation begins, or when a reset occurs.
- ERROR** - Error Interrupt. This bit is set when an error occurs. It is cleared when a data transfer operation begins or when a reset occurs. The *Error Status* register is used to determine the cause of the error.

6.13 COMMAND (CMND)

Read/Write
 Reset Value = 0x00
 Software Reset Value = 0x00

MMODE =		bit7	bit6	bit5	bit4	bit3	bit2	bit1	bit0
0	1	CMND[7:0]							
0x11	0x10								

The *Command* register is used to program the operation of the compression subsystem.

CMND[7:0]-Command. This register provides for operation as described in the following table.

CMND[7:0]	ACTION
SELECTION COMMANDS	
0xC1	Select Port A Configuration. The <i>Port A Configuration</i> and <i>Port A Polarity</i> registers are enabled for reads and writes.
0xC2	Select Port B Configuration. The <i>Port B Configuration</i> and <i>Port B Polarity</i> registers are enabled for reads and writes.
0xC4	Select Port A Interface Peripheral Access. All peripheral access addresses are enabled for reads and writes to a Port A Interface attached peripheral.
0xC8	Select Port B Interface Peripheral Access. All peripheral access addresses are enabled for reads and writes to a Port B Interface attached peripheral.
TRANSFER COMMANDS (Described in Sections 2.0 and 3.0)	
0x50	Start Compression Bypass.
0x58	Start Compression.
0x60	Start Decompression Bypass.
0x68	Start Decompression.
0x6C	Start Decompression Output Disabled.
CONTROL COMMANDS	
0x42	Pause. When a data transfer operation is in progress, any current operation steps are completed and the Port A Interface and Port B Interface data busses are placed into a high impedance state. The Paused Interrupt and Paused Status bits are then set. All data currently being processed by the data transfer operation is preserved.
0x44	Resume. A previously paused data transfer operation resumes processing. The Paused Interrupt and Paused status bits are cleared and the Busy status bit is set.
0xA0	Software Reset. The <i>Port A Configuration</i> , <i>Port B Configuration</i> , <i>Identification</i> , <i>Port A Polarity</i> , <i>Port B Polarity</i> , and <i>Command</i> registers are not affected by this command. All other registers are reset, current operations are cancelled, and the history buffer is cleared.
MISCELLANEOUS COMMANDS	
0x00	NOP, no operation is performed.

6.14 TRANSFER SIZE (TS0, TS1, TS2, TS3)

Read/Write
 Reset Value = 0x00
 Software Reset Value = 0x00

MMODE =		bit7	bit6	bit5	bit4	bit3	bit2	bit1	bit0
0	1								
0x16	0x17								TS[7:0]
0x17	0x16								TS[15:8]
0x14	0x15								TS[23:16]
0x15	0x14								TS[31:24]

TS[31:0]- Transfer Size. The *Transfer Size* register provides the microprocessor control of the number of bytes transferred during a data transfer operation. The direction of the data transfer operation specifies whether the *Port A Transfer Count* register or the *Port B Transfer Count* register is used to determine when all data bytes have been received for the data transfer operation. During compression, ATC is used. During decompression, BTC is used. When the appropriate *Transfer Count* register (ATC or BTC) equals TS, all bytes in the current data transfer operation have been received by the compression module.

6.15 DATA DISABLED COUNT (DDC0, DDC1, DDC2, DDC3)

Read/Write
 Reset Value = 0x00
 Software Reset Value = 0x00

MMODE =		bit7	bit6	bit5	bit4	bit3	bit2	bit1	bit0
0	1								
0x1A	0x1B								DDC[7:0]
0x1B	0x1A								DDC[15:8]
0x18	0x19								DDC[23:16]
0x19	0x18								DDC[31:24]

DDC[31:0]- Data Disabled Count. The *Data Disabled Count* register provides the microprocessor control of the number of bytes skipped during a Start Decompression Output Disabled operation. If the Data Disabled Count is set to 0x00 during a Start Decompression Output Disabled operation or the DDC is greater than the Transfer Size (TS) during a Start Decompression Output Disabled operation, then the Port A Interface output is disabled for the entire transfer.

6.16 ERROR MASK (EMSK)

Read/Write
 Reset Value = 0x00
 Software Reset Value = 0x00

MMODE =		bit7	bit6	bit5	bit4	bit3	bit2	bit1	bit0
0	1								
0x1C	0x1D	reserved	APERRM	BPERRM	reserved	BTCOM	ATCOM	ADCOM	ADEM

The *Error Mask* register provides error reporting configuration to the microprocessor. If an unmasked error status bit is active, ANYERR status and ERROR interrupts are set.

APERRM - Port A Interface Parity Error Mask.

BPERRM - Port B Interface Parity Error Mask.

BTCOM - Port B Transfer Count Overflow Error Mask.

ATCOM - Port A Transfer Count Overflow Error Mask.

ADCOM - ALDC Decoder Control Code Error Mask.

ADEM - ALDC Decoder End Error Mask.

6.17 INTERRUPT MASK (IMSK)

Read/Write
 Reset Value = 0x00
 Software Reset Value = 0x00

MMODE =		bit7	bit6	bit5	bit4	bit3	bit2	bit1	bit0
0	1								
0x1E	0x1F	DONEM	PAUSEDM	reserved				ERRORM	

The *Interrupt Mask* register masks the individual interrupts allowing the user to control which ones may cause the Interrupt signal pins (IREQ or IREQN) to assert. For example, if DONE and PAUSED are set with ERROR cleared, only an ERROR interrupt will cause the Interrupt signal pins to assert.

DONEM - Done Interrupt Mask.

PAUSEDM - Paused Interrupt Mask.

ERRORM - Error Interrupt Mask.

7.0 SIGNAL DESCRIPTIONS

This section contains descriptions for all the pins. Each signal has a type code associated with it. The type codes are described in the following table.

TYPE CODE	DESCRIPTION
I	Input only pin
O	Output only pin
I/O	Input/Output pin

7.1 MICROPROCESSOR INTERFACE

MICROPROCESSOR INTERFACE			
SIGNAL	TYPE	DESCRIPTION	DEFAULT AFTER RESET
MDATA[7:0]	I/O	Microprocessor data bus	Hi-Z
MCIN[0]	I	Microprocessor interface control pin [0]. If MMODE is high this pin is CSN. If MMODE is low this pin is READN.	Input
MCIN[1]	I	Microprocessor interface control pin [1]. If MMODE is high this pin is RWN. If MMODE is low this pin is WRITEN.	Input
WAITN	O	Microprocessor output signal. WAITN is driven during CSN and then goes to tristate with a resistive pullup.	High (internal pullup)
ADDR[4:0]	I	Microprocessor Interface address bus, used to select internal registers.	Input
MMODE	I	Microprocessor Interface mode selector pin.	Input
RESETN	I	Hardware reset signal, resets all registers except the <i>Identification</i> register.	Input
IREQN	O	Interrupt request output signal, open drain output. This signal requires a pull-up resistor if used by the system.	Hi-Z
IREQ	O	Interrupt request output signal, active high.	Low
CLOCK	I	Clock input	Input
TESTN[6:0]	I	Active low test pins. These pins must be tied high in the system.	Input
TRISTATEN	I	Active low testpin. Tristates all pads	Input

7.2 PORT A INTERFACE

PORT A INTERFACE			
SIGNAL	TYPE	DESCRIPTION	DEFAULT AFTER RESET
ACIN	I	Port A Interface Control Input signal. This signal functions as DACKA or DREQA. Polarity is programmed by APOL[7].	Input
ACOUT	O	Port A Interface Control Output signal. This signal functions as DACKA or DREQA. Polarity is programmed by APOL[5].	High
AWR	O	Port A Interface Control Output signal. Polarity is controlled by APOL[4].	High
ARD	O	Port A Interface Control Output signal. Polarity is controlled by APOL[3].	High
APCS	O	Port A Interface Control Output signal. Polarity is controlled by APOL[2].	High
AAF	O	Port A Interface Output signal. Port A FIFO almost full signal. Polarity is programmed by APOL[1]. Exactly when this flag gets set depends on the threshold bits in the <i>Port A Configuration 0</i> register.	High
AAE	O	Port A Interface Output signal. Port A almost empty signal. Polarity is programmed by APOL[0]. Exactly when this flag gets set depends on the threshold bits in the <i>Port A Configuration 0</i> register.	Low
APARITY[1:0]	I/O	When enabled, this pin checks parity on input and generates parity for output for the AD bus. APARITY[0] is used for AD[7:0], and APARITY[1] is used for AD[15:8]. Setting ACNF[15]=1 enables APARITY[0]. Setting ACNF[15]=1 and ACNF[10]=1 enables APARITY[1]. When disabled these pins may be tied high, tied low or not connected.	Hi-Z
ADATA[15:0]	I/O	Port A Interface Data bus. The upper eight bits [15:8] are enabled by setting ACNF[10]=1. When the upper eight bits are disabled they may be tied high, tied low, or not connected.	Hi-Z

Note: Refer to Section 5.0 Port A and Port B Configuration and Table 2 for configuration of Port A control signals.

7.3 PORT B INTERFACE

PORT B INTERFACE			
SIGNAL	TYPE	DESCRIPTION	DEFAULT AFTER RESET
BCIN	I	Port B Interface Control Input signal. This signal functions as DACKB or DREQB. Polarity is programmed by BPOL[7].	Input
BCOUT	O	Port B Interface Control Output signal. This signal functions as DACKB or DREQB. Polarity is programmed by BPOL[5].	High
BWR	O	Port B Interface Control Output signal. Polarity is controlled by BPOL[4].	High
BRD	O	Port B Interface Control Output signal. Polarity is controlled by BPOL[3].	High
BPCS	O	Port B Interface Control Output signal. Polarity is controlled by BPOL[2].	High
BAF	O	Port B Interface Output signal. Port B FIFO almost full signal. Polarity is programmed by BPOL[1]. Exactly when this flag gets set depends on the threshold bits in the <i>Port B Configuration 0</i> register.	High
BAE	O	Port B Interface Output signal. Port B almost empty signal. Polarity is programmed by BPOL[0]. Exactly when this flag gets set depends on the threshold bits in the <i>Port B Configuration 0</i> register.	Low
BPARITY[1:0]	I/O	When enabled, this pin checks parity on input and generates parity for output for the BD bus. BPARITY[0] is used for BD[7:0], and BPARITY[1] is used for BD[15:8]. Setting BCNF[15]=1 enables BPARITY[0]. Setting BCNF[15]=1 and BCNF[10]=1 enables BPARITY[1]. When disabled these pins may be tied high, tied low or not connected.	Hi-Z
BDATA[15:0]	I/O	Port B Interface Data bus. The upper eight bits [15:8] are enabled by setting BCNF[10]=1. When the upper eight bits are disabled they may be tied high, tied low, or not connected.	Hi-Z

Note: Refer to Section 5.0 Port A and Port B Configuration and Table 3 for configuration of Port B control signals.

8.0 PINOUT

<i>PIN</i>	<i>SIGNAL</i>
1	AAE
2	VDD
3	GND
4	BDATA[7]
5	BDATA[6]
6	BDATA[5]
7	BDATA[4]
8	BDATA[3]
9	BDATA[2]
10	VDD
11	GND
12	BDATA[1]
13	BAF
14	BAE
15	BDATA[0]
16	BDATA[15]
17	BDATA[14]
18	BDATA[13]
19	BDATA[12]
20	VDD
21	GND
22	BDATA[11]
23	BDATA[10]
24	BDATA[9]
25	BDATA[8]
26	BPARITY[0]
27	BPARITY[1]
28	VDD
29	GND
30	IREQN
31	IREQ
32	BPCS
33	WAITN
34	BRD
35	BWR
36	BCOUT
37	RESETN
38	TRISTATEN
39	CLK
40	GND
41	VDD
42	ADDR[4]
43	ADDR[3]
44	TESTN[0]
45	BCIN
46	GND
47	TESTN[1]
48	ADDR[2]
49	ADDR[1]
50	ADDR[0]

<i>PIN</i>	<i>SIGNAL</i>
51	ACIN
52	VDD
53	GND
54	ADATA[7]
55	ADATA[6]
56	TESTN[2]
57	ADATA[5]
58	ADATA[4]
59	ADATA[3]
60	VDD
61	GND
62	ADATA[2]
63	ARD
64	APCS
65	ADATA[1]
66	ADATA[0]
67	ADATA[15]
68	ADATA[14]
69	ADATA[13]
70	VDD
71	GND
72	ADATA[12]
73	ADATA[11]
74	ADATA[10]
75	ADATA[9]
76	ADATA[8]
77	APARITY[0]
78	VDD
79	GND
80	APARITY[1]
81	MDATA[7]
82	TESTN[3]
83	TESTN[4]
84	MDATA[6]
85	MDATA[5]
86	MDATA[4]
87	MDATA[3]
88	ACOUT
89	AWR
90	GND
91	VDD
92	MCIN[0]
93	MCIN[1]
94	MDATA[2]
95	MDATA[1]
96	MDATA[0]
97	AAF
98	MMODE
99	TESTN[5]
100	TESTN[6]

Figure 2: Pinout

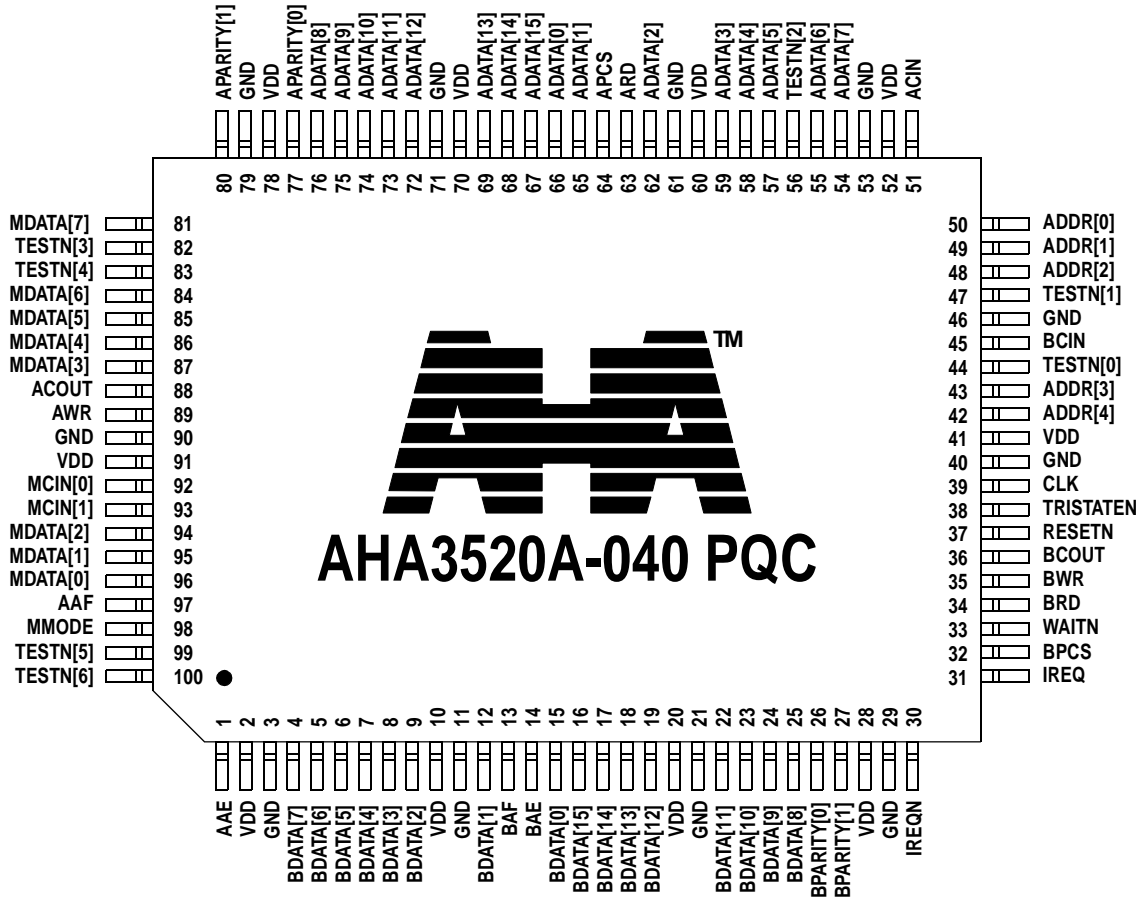

9.0 ELECTRICAL SPECIFICATIONS

9.1 ABSOLUTE MAXIMUM RATINGS

ABSOLUTE MAXIMUM RATINGS					
SYMBOL	PARAMETER	MIN	MAX	UNITS	NOTES
Vdd	Power supply voltage		7.0	Volts	
Vpin	Voltage applied to any pin	-0.5	7.0	Volts	

9.2 RECOMMENDED OPERATING CONDITIONS

RECOMMENDED OPERATING CONDITIONS					
SYMBOL	PARAMETER	MIN	MAX	UNITS	NOTES
Vdd	Power supply voltage	4.75	5.25	Volts	
Ta	Operating temperature	0	70	°C	

9.3 DC SPECIFICATIONS

DC SPECIFICATIONS						
SYMBOL	PARAMETER	CONDITIONS	MIN	MAX	UNITS	NOTES
Vil	Input low voltage			0.8	Volts	
Vih	Input high voltage		2.0		Volts	
Vol	Output low voltage	Iol = 4.0 mAmps		0.4	Volts	
Voh	Output high voltage	Ioh = -0.4 mAmps	2.4		Volts	
Iil	Input low current	Vin = 0 Volts	-10		μAmps	
Iih	Input high current	Vin = Vdd Volts		10	μAmps	
Iozl	Output tristate low current	Vout = 0 Volts		10	μAmps	
Iozh	Output tristate high current	Vout = Vdd Volts	-10		μAmps	
IddA	Active Idd current	Vdd = 5.25 Volts		250	mAmps	1
Idd	Supply current (static)			1	mAmps	
Iol	Low level output current (except IREQN) IREQN (open drain)			4	mAmps	
				8		
Ioh	High level output current			-4	mAmps	
Cin	Input capacitance			5	pF	
Cout	Output capacitance			5	pF	
CI/O	I/O capacitance			5	pF	
CL	Load Capacitance			50	pF	

Notes:

1) Test Conditions: worst case compression current; 0mA loads.

10.0 TIMING SPECIFICATIONS

Notes:

1) All AC timings are referenced to 1.4 Volts.

Figure 3: Clock Timing

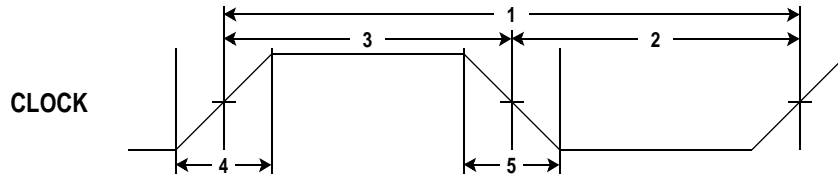

Table 4: Clock Timing

NUMBER	PARAMETER	MIN	MAX	UNITS	NOTES
1	CLK period	25		ns	1
2	CLK low pulsewidth	10		ns	1
3	CLK high pulsewidth	10		ns	1
4	CLK rise time		3	ns	2
5	CLK fall time		3	ns	2

Notes:

1) All AC Timings are referenced to 1.4 Volts

2) Rise and fall times are between 0.8 Volts and 2.0 Volts.

Figure 4: Reset Timing

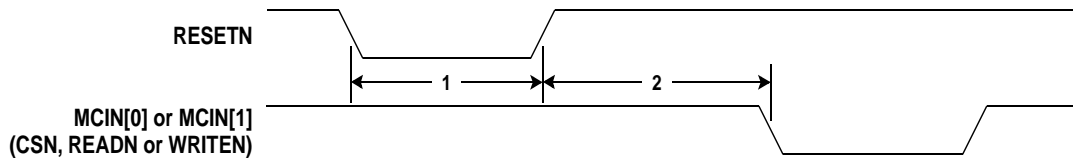

Table 5: Reset Timing

NUMBER	PARAMETER	MIN	MAX	UNITS	NOTES
1	RESETN pulsewidth	5		clocks	
2	RESETN delay to CSN, READN or WRITEN	2		clocks	

Figure 5: Almost Full/Almost Empty Timing

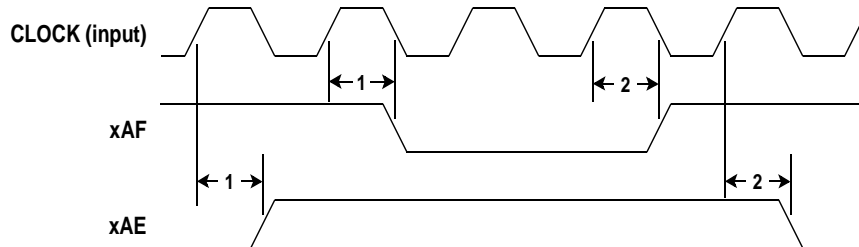

Table 6: Almost Full/Almost Empty Timing

NUMBER	PARAMETER	MIN	MAX	UNITS	NOTES
1	xAF or xAE asserted from CLOCK rise	3	26	ns	
2	xAF or xAE deasserted from CLOCK rise	3	26	ns	

Notes:

1) These timings are valid for both Port A and Port B and inverted signal polarities. Replace “x” with “A” for Port A signals and “B” for Port B signals.

Figure 6: Processor Read Timing, MMODE = 1

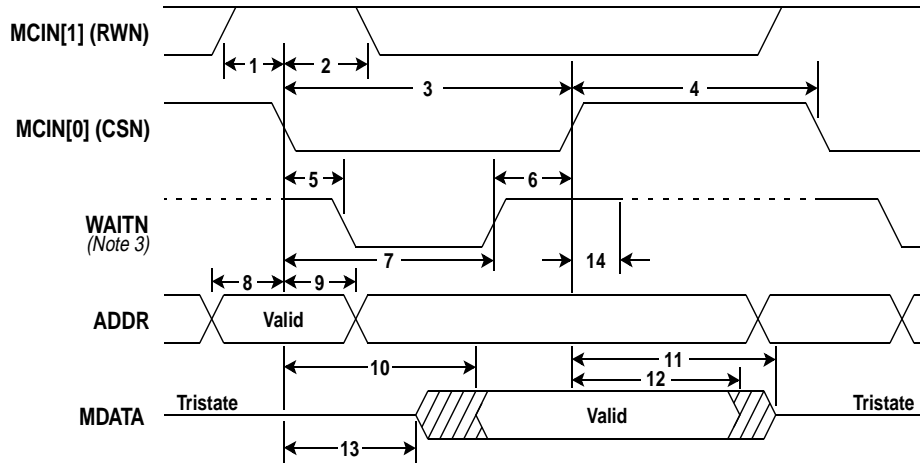

Table 7: Processor Read Timing, MMODE = 1

NUMBER	PARAMETER	MIN	MAX	UNITS	NOTES
1	RWN setup to CSN asserted	4		ns	
2	RWN hold from CSN asserted	4		ns	
3	CSN pulsewidth	3		clocks	1
4	Delay from CSN deasserted until next CSN	1 clock+5 ns			
5	CSN asserted to WAITN asserted		18	ns	
6	CSN hold from WAITN deasserted	0		ns	1
7	WAITN deasserted from CSN asserted	2 clocks	3 clocks+18 ns		
8	ADDR setup to CSN asserted	2		ns	2
9	ADDR hold from CSN asserted	6		ns	2
10	MDATA valid from CSN asserted		2 clocks+24 ns		
11	MDATA tristate from CSN deasserted	3	20	ns	
12	MDATA hold from CSN deasserted	3	20	ns	
13	CSN asserted to MDATA driven	1 clock			
14	CSN deasserted to WAITN tristate		10	ns	

Note:

- 1) When WAITN causes CSN to deassert, ignore number 3, otherwise ignore number 6.
- 2) The device latches ADDR on the falling edge of CSN. The user should latch MDATA on the rising edge of CSN.
- 3) WAITN is pulled up internally with a 10K resistor when not active and not driven low.

Figure 7: Processor Write Timing, MMODE = 1

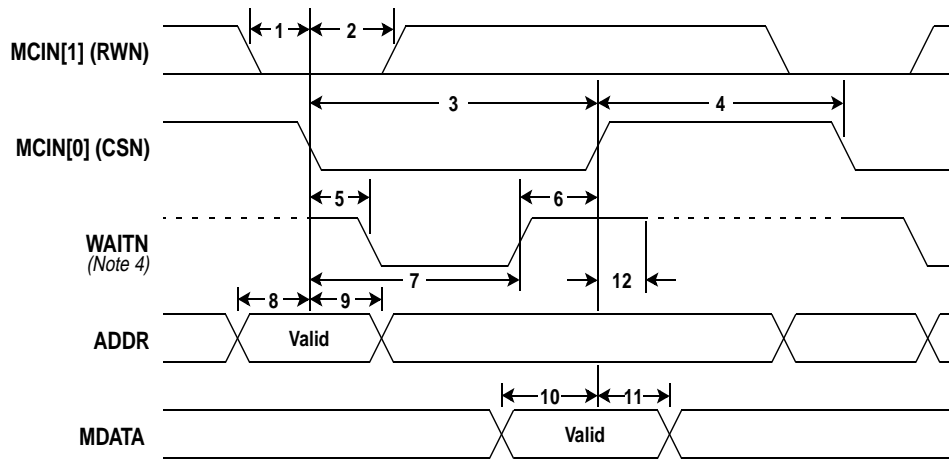

Table 8: Processor Write Timing, MMODE = 1

NUMBER	PARAMETER	MIN	MAX	UNITS	NOTES
1	RWN setup to CSN asserted	4		ns	
2	RWN hold from CSN asserted	4		ns	
3	CSN pulsewidth	2		clocks	1
4	Delay from CSN deasserted until next CSN	1 clock+5 ns			2
5	CSN asserted to WAITN asserted		18	ns	
6	CSN hold from WAITN deasserted	0		ns	1
7	WAITN deasserted from CSN asserted	1 clock	2 clocks+18 ns		
8	ADDR setup to CSN asserted	2		ns	3
9	ADDR hold from CSN asserted	6		ns	3
10	MDATA valid before CSN deasserted	4		ns	
11	MDATA hold from CSN deasserted	4		ns	
12	CSN deasserted to WAITN tristate		10	ns	

Notes:

- 1) When WAITN causes CSN to deassert, ignore number 3, otherwise ignore number 6.
- 2) When a read to a register immediately follows a write to that same register or to the command register, CSN must deassert for a minimum of 3 clocks after the write.
- 3) The device latches ADDR on the falling edge of CSN.
- 4) WAITN is pulled up internally with a 10K resistor when not active and not driven low.

Figure 8: Processor Read Timing, MMODE = 0

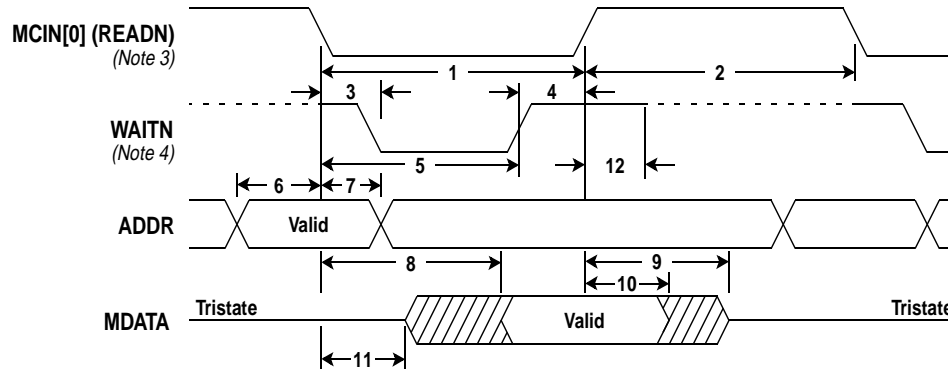

Table 9: Processor Read Timing, MMODE = 0

NUMBER	PARAMETER	MIN	MAX	UNITS	NOTES
1	READN pulsewidth	3		clocks	1
2	Delay from READN deasserted until next READN	2		clocks	
3	READN asserted to WAITN asserted		18	ns	
4	READN hold from WAITN deasserted	0		ns	1
5	WAITN deasserted from READN asserted	2 clocks	3 clocks+18 ns		
6	ADDR setup to READN asserted	2		ns	2
7	ADDR hold from READN asserted	6		ns	2
8	MDATA valid from READN asserted		2 clocks+24 ns		
9	MDATA tristate from READN deasserted		20	ns	
10	MDATA hold from READN deasserted	3		ns	
11	MDATA asserted from READN asserted	1 clock			
12	READN deasserted to WAITN tristate		10	ns	

Notes:

- 1) When WAITN causes READN to deassert ignore number 1, otherwise ignore number 4.
- 2) The device latches ADDR on the falling edge of READN. The user should latch MDATA on the rising edge of READN.
- 3) WRITEN must be deasserted during register reads.
- 4) WAITN is pulled up internally with a 10K resistor when not active and not driven low.

Figure 9: Processor Write Timing, MMODE = 0

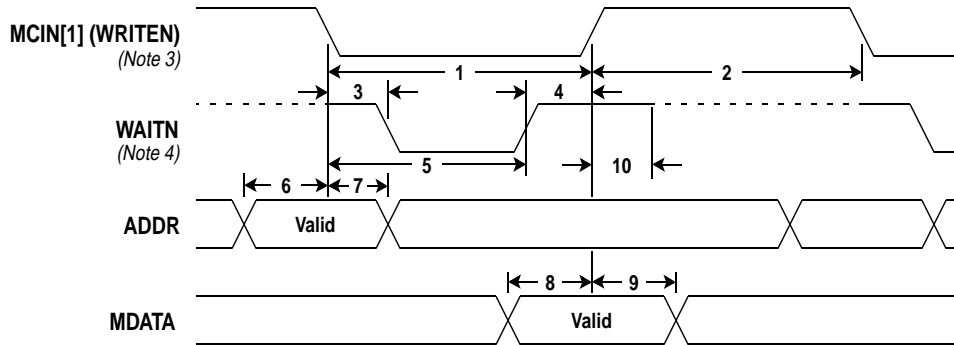

Table 10: Processor Write Timing, MMODE = 0

NUMBER	PARAMETER	MIN	MAX	UNITS	NOTES
1	WRITEN pulsewidth	2		clocks	1
2	Delay from WRITEN deasserted until next WRITEN	3		clocks	
3	WRITEN asserted to WAITN asserted		18	ns	
4	WRITEN hold from WAITN deasserted	0		ns	1
5	WAITN deasserted from WRITEN asserted	1 clock	2 clocks+18 ns		
6	ADDR setup to WRITEN asserted	2		ns	2
7	ADDR hold from WRITEN asserted	6		ns	2
8	MDATA valid before WRITEN deasserted	4		ns	
9	MDATA hold from WRITEN deasserted	4		ns	
10	WRITEN deasserted to WAITN tristate		10	ns	

Notes:

- 1) When WAITN causes WRITEN to deassert ignore number 1, otherwise ignore number 4.
- 2) The device latches ADDR on the falling edge of WRITEN.
- 3) READN must be deasserted during register writes.
- 4) WAITN is pulled up internally with a 10K resistor when not active and not driven low.

Figure 10: Port A/B Timing, Four Edge, Master Mode

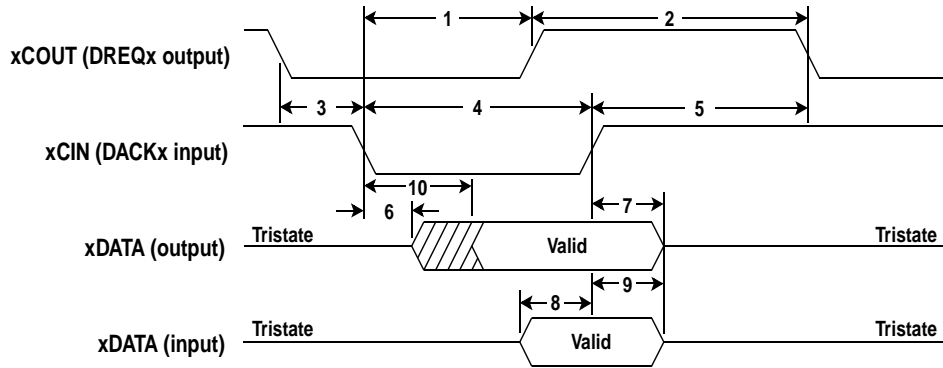

Table 11: Port A/B Timing, Four Edge, Master Mode

NUMBER	PARAMETER	MIN	MAX	UNITS	NOTES
1	DACKx asserted to DREQx deasserted		20	ns	1
2	Delay from DREQx deasserted to next DREQx	2 clocks–5 ns			1
3	DREQx asserted to DACKx asserted	1		clocks	1
4	DACKx pulsewidth	2		clocks	1
5	Delay from DACKx deasserted to next DREQx	1		clocks	1
6	xDATA (output) driven from DACKx asserted	2		ns	1
7	xDATA (output) hold from DACKx deasserted	2	23	ns	1, 2
8	xDATA (input) valid before DACKx deasserted	4		ns	1
9	xDATA (input) hold from DACKx deasserted	8		ns	1
10	xDATA (output) valid from DACKx asserted		23	ns	1

Notes:

- 1) These timings are valid for both Port A and Port B and inverted signal polarities. Replace “x” with “A” for Port A signals and “B” for Port B signals.
- 2) Internal bus keepers hold the xDATA until overdriven.

Figure 11: Port A/B Timing, Four Edge, Slave Mode

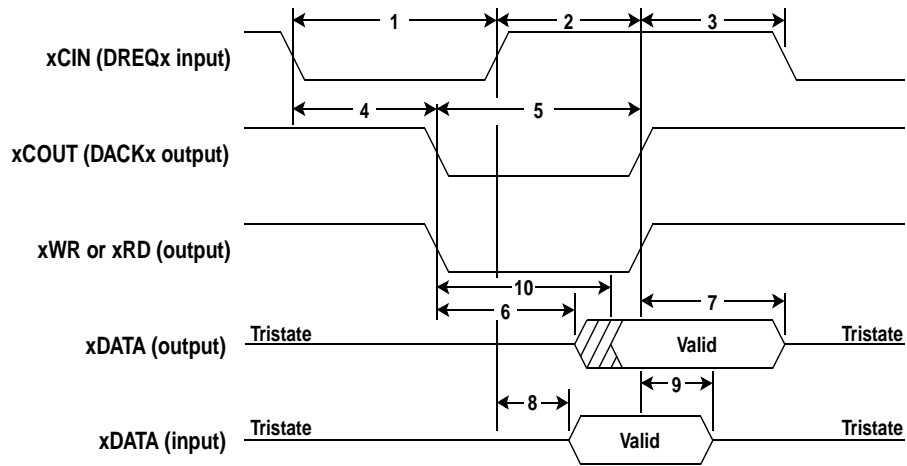

Table 12: Port A/B Timing, Four Edge, Slave Mode

NUMBER	PARAMETER	MIN	MAX	UNITS	NOTES
1	DREQx pulsewidth	2		clocks	1
2	DACKx deasserted from DREQx deasserted	1 clock	2 clocks+22 ns		1
3	Delay from DACKx deasserted to next DREQx	0		ns	1
4	DREQx asserted to DACKx asserted	1		clocks	1
5	DACKx pulsewidth	2 clocks-8 ns			1
6	xDATA (output) driven from DACKx asserted	1 clock-5 ns			1
7	xDATA (output) hold from DACKx deasserted	1 clock-10 ns	1 clock+5 ns		1, 2
8	xDATA (input) valid after DREQx deasserted		1 clock-5 ns		1
9	xDATA (input) hold from DACKx deasserted	0		ns	1
10	xDATA (output) valid from DACKx asserted		1 clock+10 ns		1

Notes:

- 1) These timings are valid for both Port A and Port B and inverted signal polarities. Replace “x” with “A” for Port A signals and “B” for Port B signals.
- 2) Internal bus keeps hold the xDATA until overdriven.

Figure 12: Port A/B Timing, Burst, Master Mode

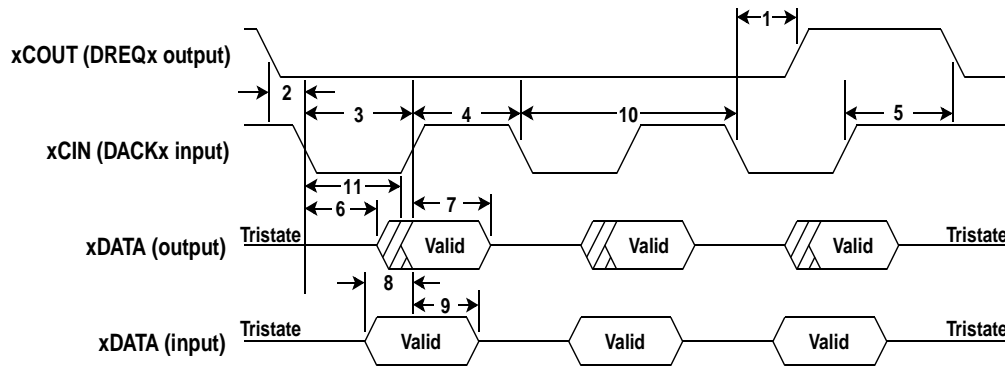

Table 13: Port A/B Timing, Burst, Master Mode

NUMBER	PARAMETER	MIN	MAX	UNITS	NOTES
1	Last DACKx asserted to DREQx deasserted, end of burst		20	ns	1
2	DREQx asserted to first DACKx asserted, start of burst	1		clocks	1
3	DACKx pulsewidth	2 clocks–10 ns			1
4	DACKx deasserted to DACKx asserted	2 clocks–10 ns			1
5	Last DACKx deasserted to next DREQx asserted, next burst	2		clocks	1
6	xDATA (output) driven from DACKx asserted	2		ns	1
7	xDATA (output) hold from DACKx deasserted	2	23	ns	1, 2
8	xDATA (input) valid before DACKx deasserted	4		ns	1
9	xDATA (input) hold from DACKx deasserted	8		ns	1
10	DACKx cycle time	4		clocks	1
11	xDATA (output) valid from DACKx asserted		23	ns	1

Notes:

- 1) These timings are valid for both Port A and Port B and inverted signal polarities. Replace “x” with “A” for Port A signals and “B” for Port B signals.
- 2) Internal bus keepers hold the xDATA until overdriven.

Figure 13: Port A/B Timing, Burst, Slave Mode

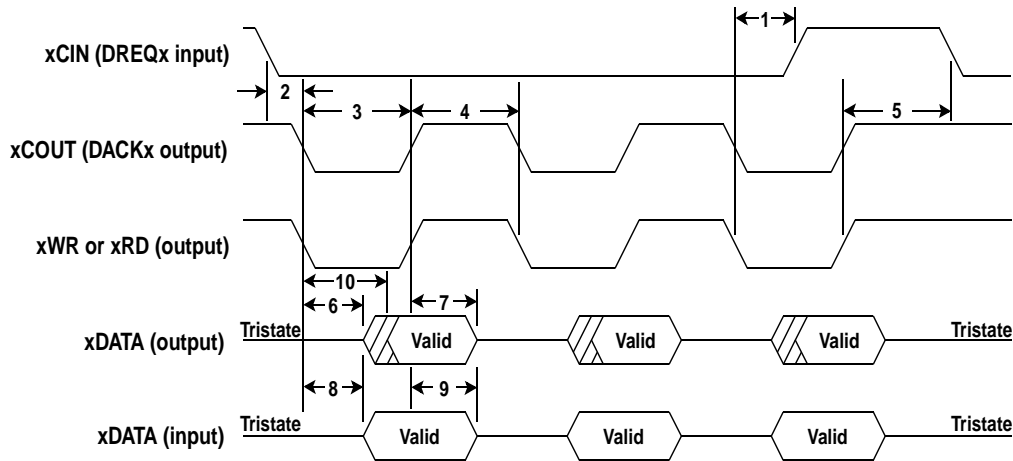

Table 14: Port A/B Timing, Burst, Slave Mode

NUMBER	PARAMETER	MIN	MAX	UNITS	NOTES
1	Last DACKx asserted to DREQx deasserted, end of burst	0 ns	3 clocks–22 ns		1
2	DREQx asserted to first DACKx asserted, start of burst	1		clocks	1
3	DACKx pulsewidth	2 clocks–8 ns	2 clocks+8 ns		1
4	DACKx deasserted to DACKx asserted	2 clocks–8 ns			1
5	Last DACKx deasserted to next DREQx asserted, next burst	2		clocks	1
6	xDATA (output) driven from DACKx asserted	1 clock–5 ns			1
7	xDATA (output) hold from DACKx deasserted	1 clock–10 ns	1 clock+5 ns		1, 2
8	xDATA (input) valid after DACKx asserted		2 clocks–18 ns		1
9	xDATA (input) hold from DACKx deasserted	0		ns	1
10	xDATA (output) valid from DACKx asserted		1 clock+10 ns	ns	1

Notes:

- 1) These timings are valid for both Port A and Port B and inverted signal polarities. Replace “x” with “A” for Port A signals and “B” for Port B signals.
- 2) Internal bus keepers hold the xDATA until overdriven.

Figure 14: Peripheral Access Read Timing, MMODE = 1

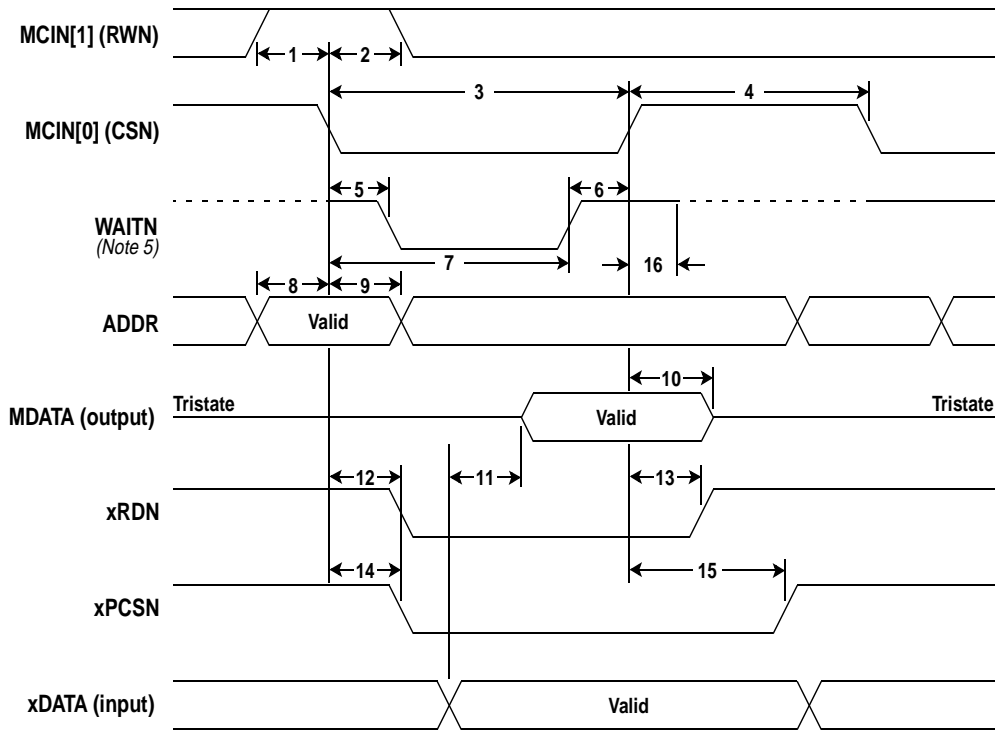

Table 15: Peripheral Access Read Timing, MMODE = 1

NUMBER	PARAMETER	MIN	MAX	UNITS	NOTES
1	RWN setup to CSN asserted	4		ns	
2	RWN hold from CSN asserted	4		ns	
3	CSN pulsewidth	(n+1)		clocks	1, 2
4	Delay from CSN deasserted until next CSN	2		clocks	
5	CSN asserted to WAITN asserted	5	18	ns	
6	CSN hold from WAITN deasserted	0		ns	1
7	WAITN deasserted from CSN asserted	n clocks	(n+1) clocks +18 ns		2
8	ADDR setup to CSN asserted	4		ns	3
9	ADDR hold from CSN asserted	4		ns	3
10	MDATA (output) hold from CSN deasserted	3	20	ns	
11	MDATA (output) valid from xDATA (input) valid		19	ns	4
12	xRDN asserted from CSN asserted	1 clock	2 clocks+21 ns		4
13	xRDN deasserted from CSN deasserted	1 clock	2 clocks+21 ns		4
14	xPCSN asserted from CSN asserted	1 clock	2 clocks+21 ns		4
15	xPCSN deasserted from CSN deasserted	1 clock	2 clocks+21 ns		4
16	CSN deasserted to WAITN tristate	0	10	ns	

Notes:

- 1) When WAITN causes CSN to deassert ignore number 3, otherwise ignore number 6.
- 2) "n" is the number of wait states programmed into the xCNF registers.
- 3) The device latches ADDR on the falling edge of CSN. The user should latch MDATA on the rising edge of CSN.
- 4) These timings are valid for both Port A and Port B and inverted signal polarities. Replace "x" with "A" for Port A signals and "B" for Port B signals.
- 5) WAITN is pulled up internally with a 10K resistor when not active and not driven low.

Figure 15: Peripheral Access Write Timing, MMODE = 1

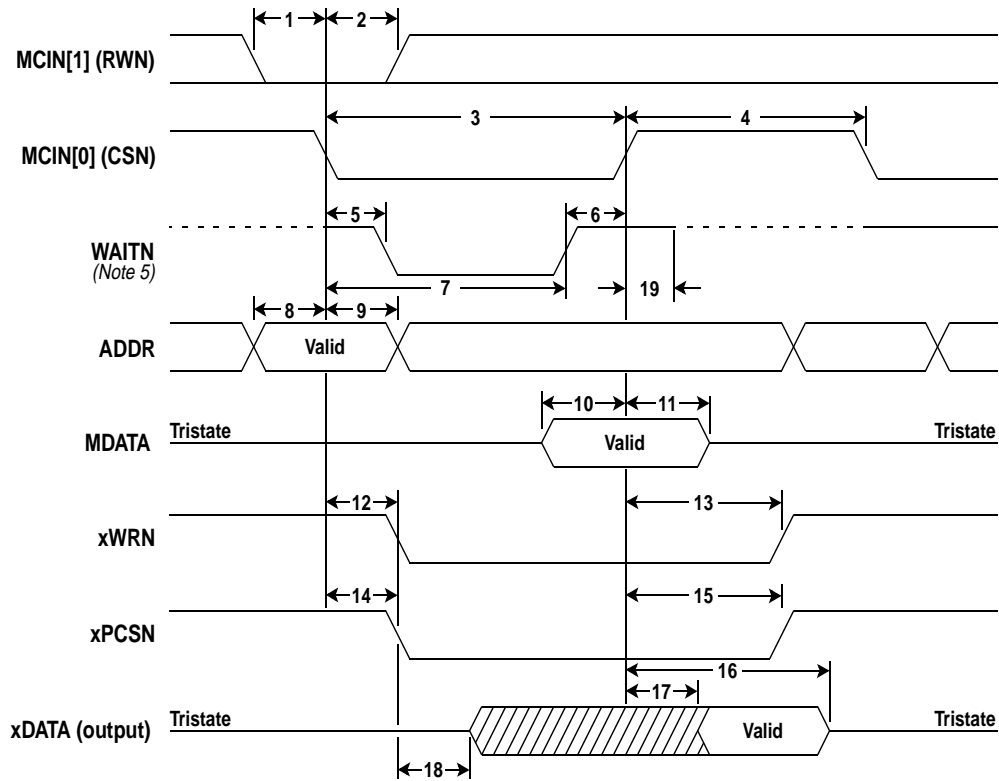

Table 16: Peripheral Access Write Timing, MMODE = 1

NUMBER	PARAMETER	MIN	MAX	UNITS	NOTES
1	RWN setup to CSN asserted	4		ns	
2	RWN hold from CSN asserted	4		ns	
3	CSN pulsewidth	(n+1)		clocks	1, 2
4	Delay from CSN deasserted until next CSN	3		clocks	6
5	CSN asserted to WAITN asserted	5	18	ns	
6	CSN hold from WAITN deasserted	0		ns	1
7	WAITN deasserted from CSN asserted	n clocks	(n+1) clocks+18 ns		2
8	ADDR setup to CSN asserted	4		ns	3
9	ADDR hold from CSN asserted	4		ns	3
10	MDATA valid before CSN deasserted	4		ns	
11	MDATA hold from CSN deasserted	4		ns	
12	xWRN asserted from CSN asserted	1 clock	2 clocks+21 ns		4
13	xWRN deasserted from CSN deasserted	1 clock	2 clocks+21 ns		4
14	xPCSN asserted from CSN asserted	1 clock	2 clocks+21 ns		4
15	xPCSN deasserted from CSN deasserted	1 clock	2 clocks+21 ns		4
16	xDATA (output) tristated from CSN deasserted	2 clocks	3 clocks+17 ns		4
17	xDATA valid from CSN deasserted		19	ns	4
18	CSN asserted to xDATA driven	1 clock			
19	MCIN[0] inactive to WAITN tristate	0	10	ns	

Notes:

- 1) When WAITN causes CSN to deassert ignore number 3, otherwise ignore number 6.
- 2) "n" is the number of wait states programmed into the xCNF registers.
- 3) The device latches ADDR on the falling edge of CSN.
- 4) These timings are valid for both Port A and Port B and inverted signal polarities. Replace "x" with "A" for Port A signals and "B" for Port B signals.
- 5) WAITN is pulled up internally with a 10K resistor when not active and not driven low.
- 6) This timing applies to before a write access as well as after.

Figure 16: Peripheral Access Read Timing, MMODE = 0

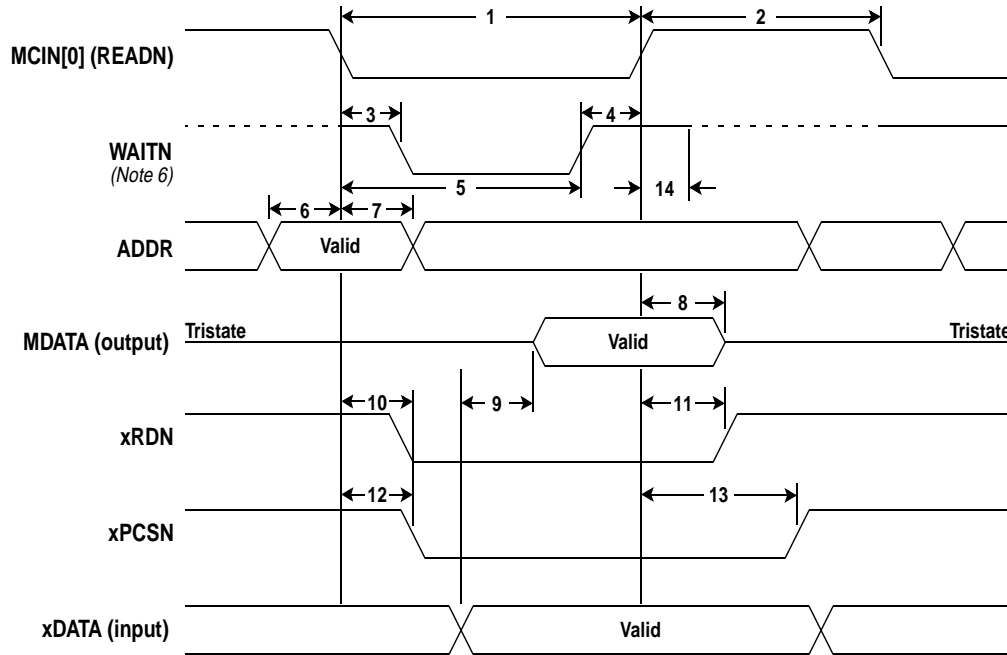

Table 17: Peripheral Access Read Timing, MMODE = 0

NUMBER	PARAMETER	MIN	MAX	UNITS	NOTES
1	READN pulsewidth	(n+1)		clocks	1, 2
2	Delay from READN deasserted until next READN	2		clocks	
3	READN asserted to WAITN asserted	5	18	ns	
4	READN hold from WAITN deasserted	0		ns	1
5	WAITN deasserted from READN asserted	n clocks	(n+1) clocks+18 ns		2
6	ADDR setup from READN asserted	4		ns	2
7	ADDR hold from READN asserted	4		ns	2
8	MDATA (output) hold from READN deasserted	3	20	ns	
9	MDATA (output) valid from xDATA (input) valid		19	ns	5
10	xRDN asserted from READN asserted	1 clock	2 clocks+21 ns		5
11	xRDN deasserted from READN deasserted	1 clock	2 clocks+21 ns		5
12	xPCSN asserted from READN asserted	1 clock	2 clocks+21 ns		5
13	xPCSN deasserted from READN deasserted	1 clock	2 clocks+21 ns		5
14	READN deasserted to WAITN tristate	0	10	ns	

Notes:

- 1) When WAITN causes READN to deassert ignore number 1, otherwise ignore number 4.
- 2) The device latches ADDR on the falling edge of READN. The user should latch MDATA on the rising edge of READN.
- 3) WRITEN must be deasserted during register reads.
- 4) "n" is the number of wait states programmed into the xCNF registers.
- 5) These timings are valid for both Port A and Port B and inverted signal polarities. Replace "x" with "A" for Port A signals and "B" for Port B signals.
- 6) WAITN is pulled up internally with a 10K resistor when not active and not driven low.

Figure 17: Peripheral Access Write Timing, MMODE = 0

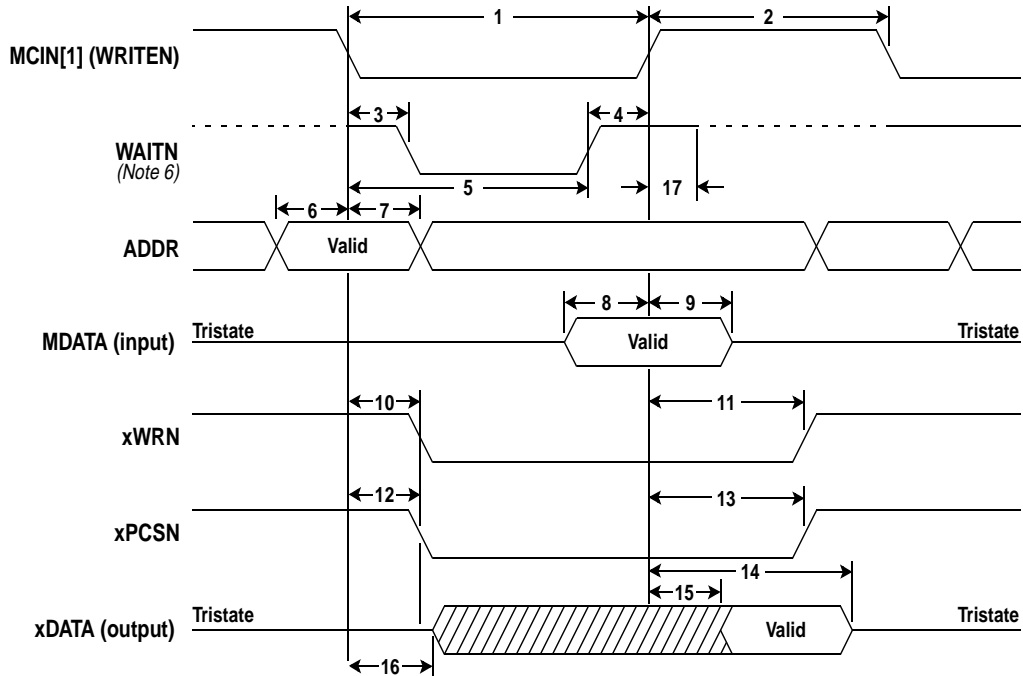

Table 18: Peripheral Access Write Timing, MMODE = 0

NUMBER	PARAMETER	MIN	MAX	UNITS	NOTES
1	WRITEN pulsewidth	(n+1)		clocks	1, 2
2	Delay from WRITEN deasserted until next WRITEN	3		clocks	
3	WRITEN asserted to WAITN asserted	5	18	ns	
4	WRITEN hold from WAITN deasserted	0		ns	1
5	WAITN deasserted from WRITEN asserted	n clocks	(n+1) clocks+18 ns		2
6	ADDR setup from WRITEN asserted	4		ns	2
7	ADDR hold from WRITEN asserted	4		ns	2
8	MDATA valid before WRITEN deasserted	4		ns	
9	MDATA hold from WRITEN deasserted	4		ns	
10	xWRN asserted from WRITEN asserted	1 clock	2 clocks+21 ns		5
11	xWRN deasserted from WRITEN deasserted	1 clock	2 clocks+21 ns		5
12	xPCSN asserted from WRITEN asserted	1 clock	2 clocks+21 ns		5
13	xPCSN deasserted from WRITEN deasserted	1 clock	2 clocks+21 ns		5
14	xDATA (output) tristated from WRITEN deasserted	2 clocks	3 clocks+17 ns		5
15	xDATA valid from WRITEN deasserted		19	ns	5
16	WRITEN asserted to xDATA driven	1 clock			5
17	WRITEN inactive to WAITN tristate	0	10	ns	

Notes:

- 1) When WAITN causes WRITEN to deassert ignore number 1, otherwise ignore number 4.
- 2) The device latches ADDR on the falling edge of WRITEN.
- 3) READN must be deasserted during register writes.
- 4) “n” is the number of wait states programmed into the xCNF registers.
- 5) These timings are valid for both Port A and Port B and inverted signal polarities. Replace “x” with “A” for Port A signals and “B” for Port B signals.
- 6) WAITN is pulled up internally with a 10K resistor when not active and not driven low.

11.0 PACKAGING

Figure 18: AHA3520 PQFP Package Specifications

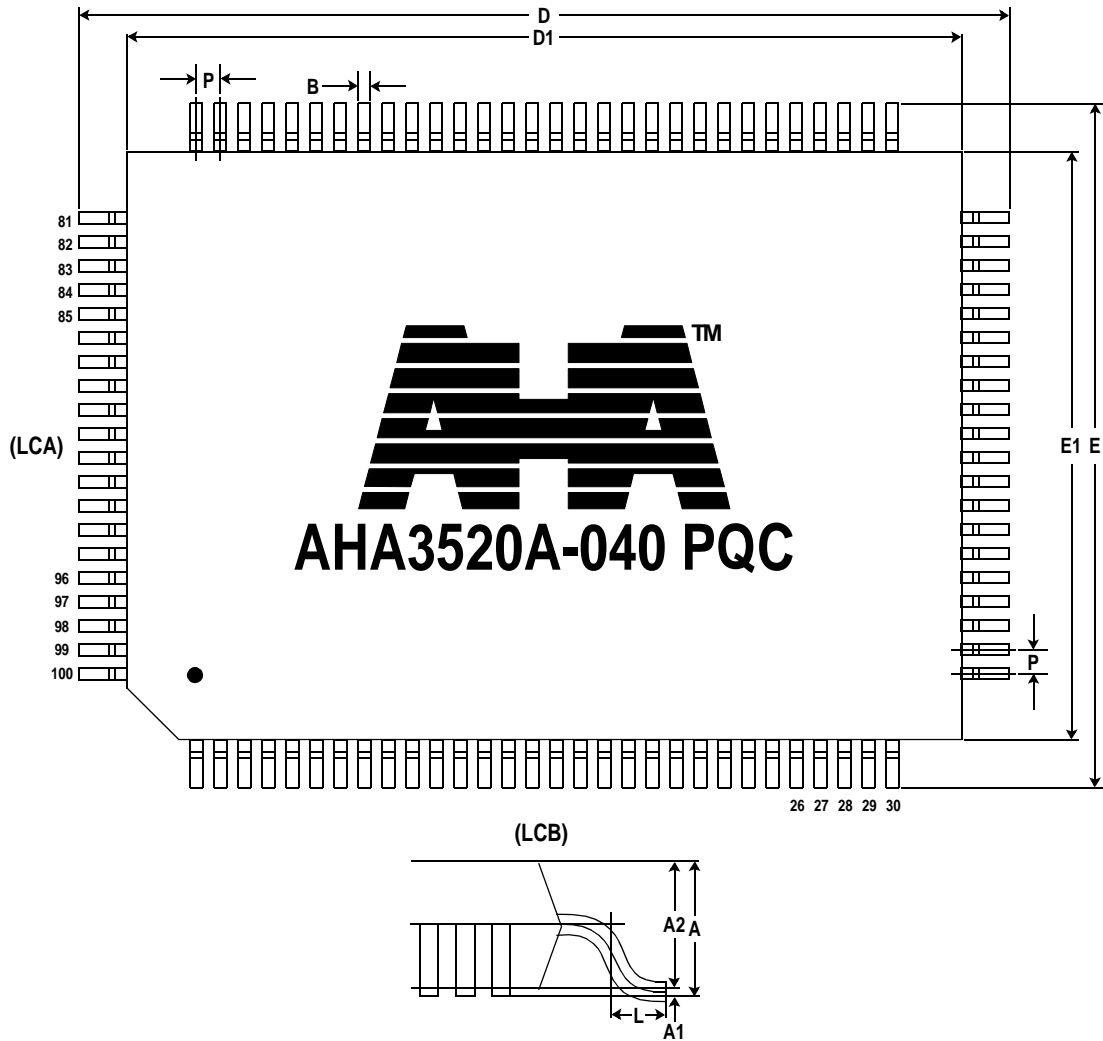

Table 19: PQFP (Plastic Quad Flat Pack) 14 mm x 20 mm Package Dimensions

(All dimensions are in mm)

SYMBOL	NUMBER OF PIN AND SPECIFICATION DIMENSION		
	100		
	RB		
	MIN	NOM	MAX
(LCA)	20		
(LCB)	30		
A			3.1
A1	0.1	0.23	0.36
A2	2.57	2.71	2.87
D	23.65	23.9	24.15
D1	19.9	20	20.1
E	17.65	17.9	18.15
E1	13.9	14	14.1
L	0.73	0.88	1.03
P		0.65	
B	0.22	0.3	0.33

JEDEC Outline MO-112

12.0 ORDERING INFORMATION

12.1 AVAILABLE PARTS

<i>PART NUMBER</i>	<i>DESCRIPTION</i>
AHA3520A-040 PQC	20 MBytes/sec ALDC Data Compression Coprocessor IC with Enhanced Features, PQFP

12.2 PART NUMBERING

<i>AHA</i>	<i>3520</i>	<i>A-</i>	<i>040</i>	<i>P</i>	<i>Q</i>	<i>C</i>
Manufacturer	Device Number	Revision Level	Speed Designation	Package Material	Package Type	Test Specification

Device Number:

3520

Revision Letter:

A

Package Material Codes:

P Plastic

Package Type Codes:

Q Q - Quad Flat Pack

Test Specifications:

C Commercial 0°C to +70°C

13.0 AHA RELATED TECHNICAL PUBLICATIONS

<i>DOCUMENT #</i>	<i>DESCRIPTION</i>
PB3520	AHA Product Brief – AHA3520 20 MBytes/sec ALDC Data Compression Coprocessor IC
PB3521	AHA Product Brief – AHA3521 20 MBytes/sec ALDC Data Compression Coprocessor IC with Enhanced Features
PS3521	AHA Product Specification – AHA3521 20 MBytes/sec ALDC Data Compression Coprocessor IC with Enhanced Features
ANDC18	AHA Application Note – Differences between AHA and IBM Devices
ANDC19	AHA Application Note – Designer’s Guide for ALDC Compression/Decompression Devices: AHA3520 and AHA3521