

Open Loop Phase Control Circuit

Description

The integrated circuit, U208B, is designed as a phase control circuit in bipolar technology with internal supply-voltage monitoring. As the voltage is built up, uncontrolled output pulses are avoided by internal

monitoring. Furthermore, it has internal-current and voltage synchronisation. It is recommended as a low cost open-loop control.

Features

- Automatic retriggering
- Triggering pulse typ. 125 mA
- Voltage and current synchronisation

- Internal supply voltage monitoring
- Current requirement ≤ 2.5 mA

Package: DIP8

Block Diagram

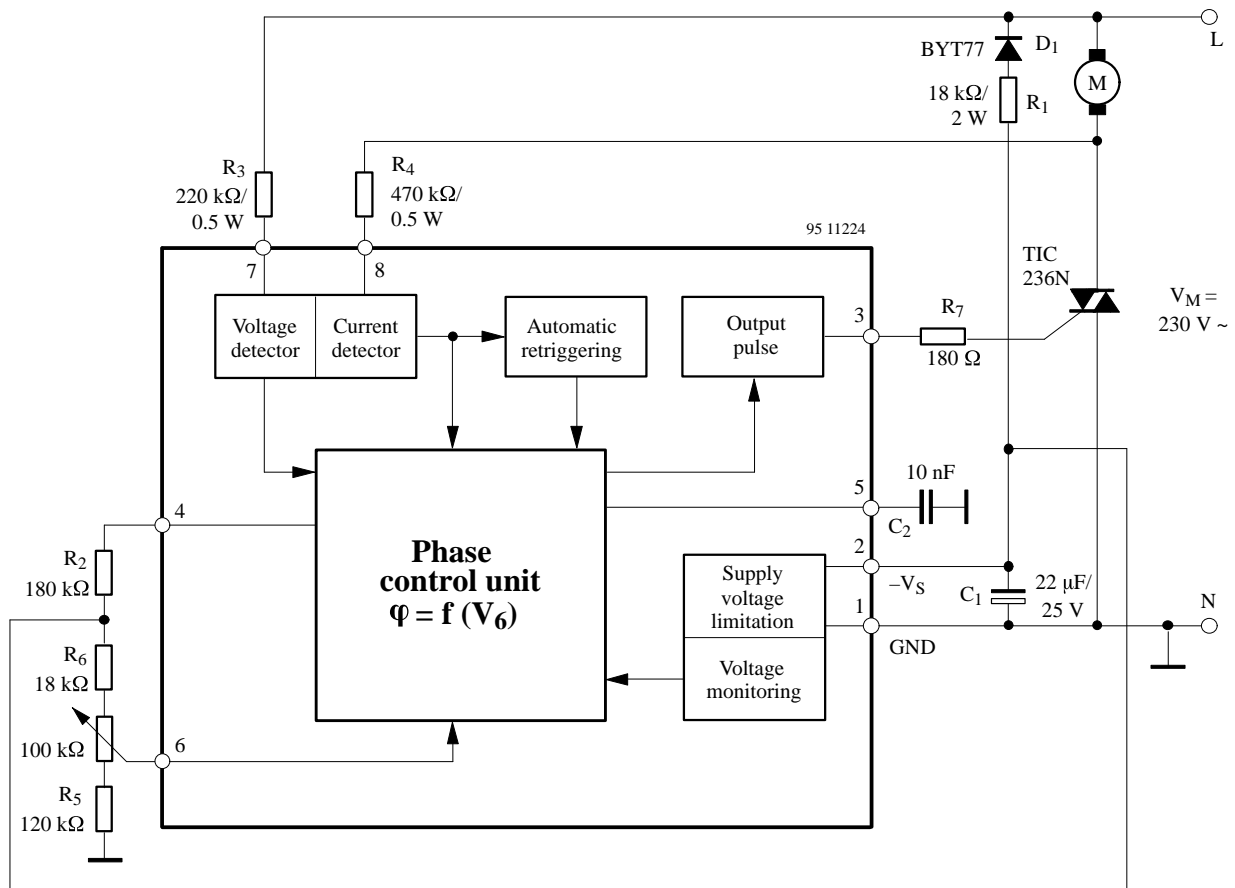

Figure 1. Block diagram for simple phase control system

Description

Mains Supply

The U208B is fitted with voltage limiting and can therefore be supplied directly from the mains. The supply voltage between Pin 1 (+ pol/⊥) and Pin 2 builds up across D_1 and R_1 and is smoothed by C_1 . The value of the series resistance can be approximated using figure 1:

$$R_1 = \frac{V_M - V_S}{2 I_S}$$

Further information regarding the design of the mains supply can be found in the data sheets in the appendix. Operation using an externally stabilized DC voltage is not recommended.

If the supply cannot be taken directly from the mains because the power dissipation in R_1 would be too large, then the circuit shown in the following figure 2 should be employed.

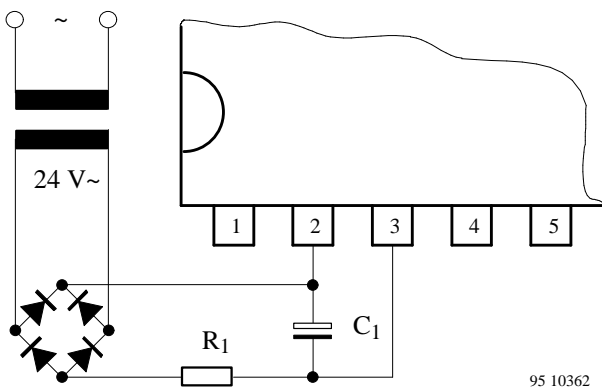

Figure 2. Supply voltage for high current requirements

Phase Control

The function of the phase control is largely identical to that of the well known component TEA1007. The phase angle of the trigger pulse is derived by comparing the ramp voltage, which is mains synchronized by the voltage detector, with the nominal value predetermined at the control input Pin 6. The slope of the ramp is determined by C_2 and its charging current. The charging current can be varied using R_2 on Pin 4. The maximum phase angle α_{max} can also be adjusted using R_2 .

When the potential on Pin 5 reaches the given value of Pin 6, then a trigger pulse is generated whose width t_p is determined by the value of C_2 (the value of C_2 and hence the pulse width can be evaluated by assuming $8 \mu s/nF$).

The current sensor on Pin 8 ensures that, for operation with inductive loads, no pulse will be generated in a new half cycle as long as the current from the previous half cycle is still flowing in the opposite direction to the supply voltage at that instant. This makes sure that "Gaps" in the load current are prevented. The control signal on Pin 6 can be in the range 0 V to -7 V (reference point Pin 1).

If $V_{pin6} = -7$ V then the phase angle is at maximum = α_{max} i.e., the current flow angle is a minimum. The minimum phase angle α_{min} is when $V_{pin6} = V_{pin1}$.

Voltage Monitoring

As the voltage is built up, uncontrolled output pulses are avoided by internal voltage surveillance. At the same time, all of the latches in the circuit are reset. Used with a switching hysteresis of 300 mV, this system guarantees defined start-up behavior each time the supply voltage is switched on, or after short interruptions of the mains supply.

Pulse Output Stage

The pulse output stage is short circuit protected and can typically deliver currents of 125 mA. For the design of smaller triggering currents, the function $I_{GT} = f(R_{GT})$ has been given in the data sheets in the appendix. In contrast to the TEA1007, the pulse output stage of the U 208 B has no gate bypass resistor.

Automatic Retriggering

The automatic retriggering prevents half cycles without current flow, even if the triacs is turned off earlier e.g. due to a collector which is not exactly centered (brush lifter) or in the event of unsuccessful triggering. If it is necessary, another triggering pulse is generated after a time lapse of $t_{pp} = 4.5 t_p$ and this is repeated until either the triac fires or the half cycle finishes.

General Hints and Explanation of Terms

To ensure safe and trouble-free operation, the following points should be taken into consideration when circuits are being constructed or in the design of printed circuit boards.

- The connecting lines from C₂ to Pin 5 and Pin 1 should be as short as possible, and the connection to Pin 1 should not carry any additional high current such as e.g. the load current.
- When selecting C₂, a low temperature coefficient is desirable.

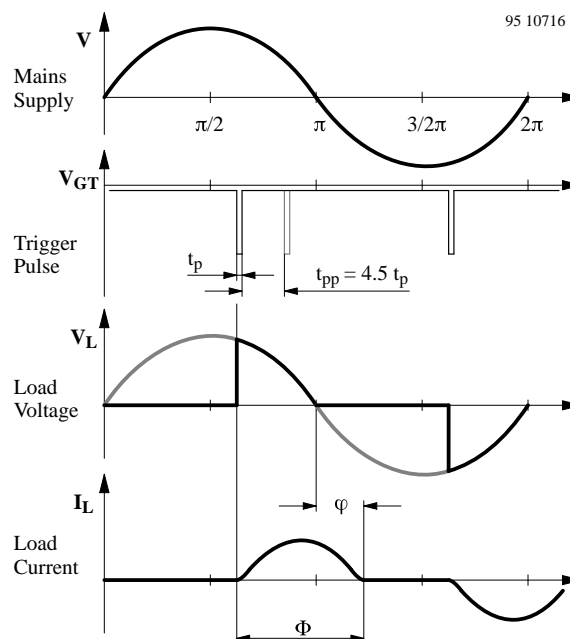

Figure 3. Explanation of terms in phase relationship

Absolute Maximum Ratings

Reference point Pin 1, unless otherwise specified

| Parameters | Symbol | Value | Unit |
|---|--|--------------------|------------------|
| Current requirement Pin 2 $t \leq 10 \mu\text{s}$ | $-I_S$ | 30 | mA |
| | $-i_s$ | 100 | |
| Synchronisation current Pin 8 Pin 7 $t < 10 \mu\text{s}$ Pin 8 Pin 7 $t < 10 \mu\text{s}$ | I_{syncI} I_{syncV} $\pm i_I$ $\pm i_V$ | 5 5 35 35 | mA |
| Phase control Input voltage Pin 6 Input current Pin 6 Pin 4 | $-V_I$ $\pm I_I$ I_I | 0 to 7 500 1 | |
| Power dissipation $T_{\text{amb}} = 45^\circ\text{C}$ $T_{\text{amb}} = 80^\circ\text{C}$ | P_{tot} | 530 300 | mW |
| Storage temperature range | T_{stg} | -40 to +125 | $^\circ\text{C}$ |
| Junction temperature | T_j | 125 | $^\circ\text{C}$ |
| Ambient temperature range | T_{amb} | -10 to +100 | $^\circ\text{C}$ |

Thermal Resistance

| Parameters | Symbol | Value | Unit |
|--------------------|------------|-------|------|
| Junction ambient | R_{thJA} | 120 | K/W |
| DIP8 | | 220 | |
| SO8: on p.c. board | | 140 | |
| SO8: on ceramic | | | |

Electrical Characteristics

$-V_S = 13.0\text{ V}$, $T_{amb} = 25\text{ }^\circ\text{C}$, reference point pin 1, unless otherwise specified

| Parameters | Test Conditions / Pins | Symbol | Min. | Typ. | Max. | Unit |
|-------------------------------------|---|------------------------|--------------|------------|--------------|---------------|
| Supply voltage for mains operations | Pin 2 | $-V_S$ | 13.0 | | V_{Limit} | V |
| Supply voltage limitation | $-I_S = 3\text{ mA}$ $-I_S = 30\text{ mA}$ Pin 2 | $-V_S$ | 14.6 14.7 | | 16.6 16.8 | V |
| DC supply current | $-V_S = 13\text{ V}$ Pin 2 | $-I_S$ | 1.0 | 2.2 | 2.5 | mA |
| Voltage monitoring | | | | | | |
| Turn-on threshold | Pin 2 | $-V_{SON}$ | | 11.2 | 13.0 | V |
| Turn-off threshold | Pin 2 | $-V_{SOFF}$ | 9.9 | 10.9 | | V |
| Phase control currents | | | | | | |
| Current synchronisation | Pin 8 | $I_{sync.I}$ | 0.35 | | 3.5 | mA |
| Voltage synchronisation | Pin 7 | $I_{sync.V}$ | 0.35 | | 3.5 | mA |
| Voltage limitation | $\pm I_I = 5\text{ mA}$ Pin 8 Pin 7 | $\pm V_I$ $\pm V_I$ | 8.0 8.0 | 8.9 8.9 | 9.5 9.5 | V |
| Reference ramp figure 4 | | | | | | |
| Load current | $I_S = f(R_4)$ Pin 5 | I_5 | 1 | | 20 | μA |
| R_φ -reference voltage | Pin 4, 2 | $V_{\varphi Ref}$ | 1.06 | 1.13 | 1.18 | V |
| Temperature coefficient | Pin 4 | $TC_{V_{\varphi Ref}}$ | | -0.5 | | mV/K |
| Pulse output | | | | | | |
| Output pulse current | $R_7 = 0$, $V_{GT} = 1.2\text{ V}$ Pin 3 | I_o | 100 | 125 | 150 | mA |
| Reverse current | Pin 3 | I_{or} | | 0.01 | 3.0 | μA |
| Output pulse width | $C_\varphi = 10\text{ nF}$ Pin 5-1 | t_p | | 80 | | μs |
| Automatic retriggering | | | | | | |
| Repetition rate | Pin 3, 5 | t_{pp} | 3 | 4.5 | 6 | t_p |

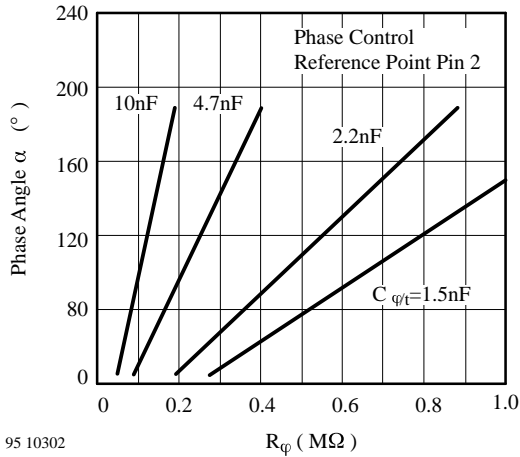

Figure 4.

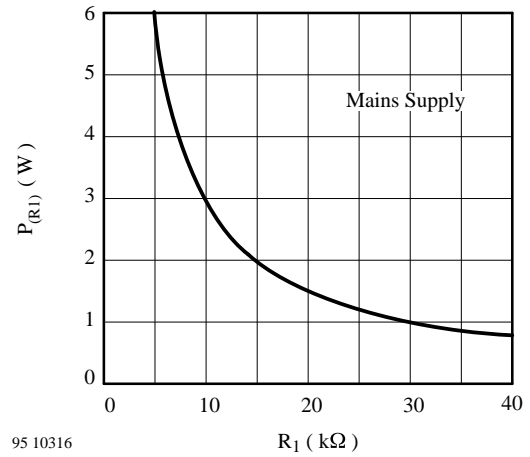

Figure 6.

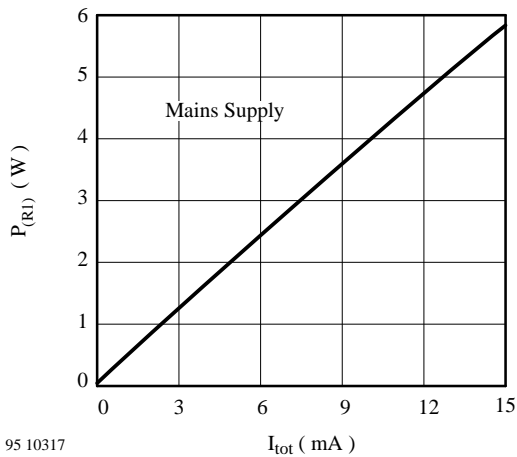

Figure 5.

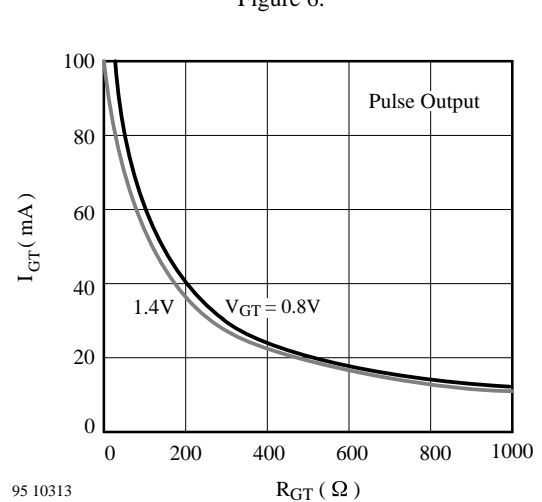

Figure 7.

Design Calculations for Mains Supply

The following equations can be used for evaluating the series resistor R_1 for worst case conditions:

$$R_{1max} = 0.85 \times \frac{V_{Mmin} - V_{Smax}}{2 I_{tot}}$$

$$R_{1min} = \frac{V_{Mmax} - V_{Mmin}}{2 I_{Smax}} \quad P_{(R1max)} = \frac{(V_{Mmax} - V_{Smin})^2}{2 R_1}$$

where:

- V_M = Mains voltage
- V_S = Supply voltage on Pin 4
- I_{tot} = Total DC current requirement of the circuit
= $I_S + I_p + I_x$
- I_S = Current requirement of the IC in mA
- I_p = Average current requirement of the triggering pulses
- I_x = Current requirement of other peripheral components

R_1 can be easily evaluated from figures 6 and 8

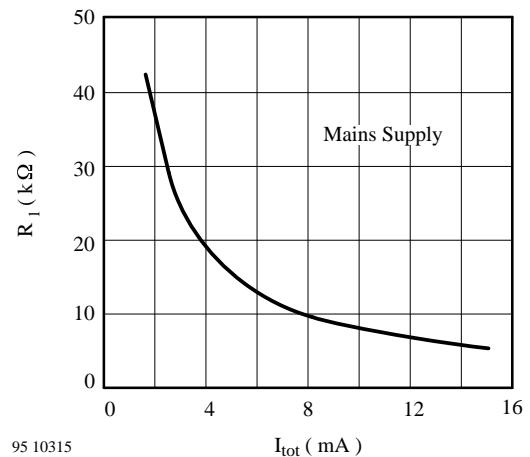

Figure 8.

Application

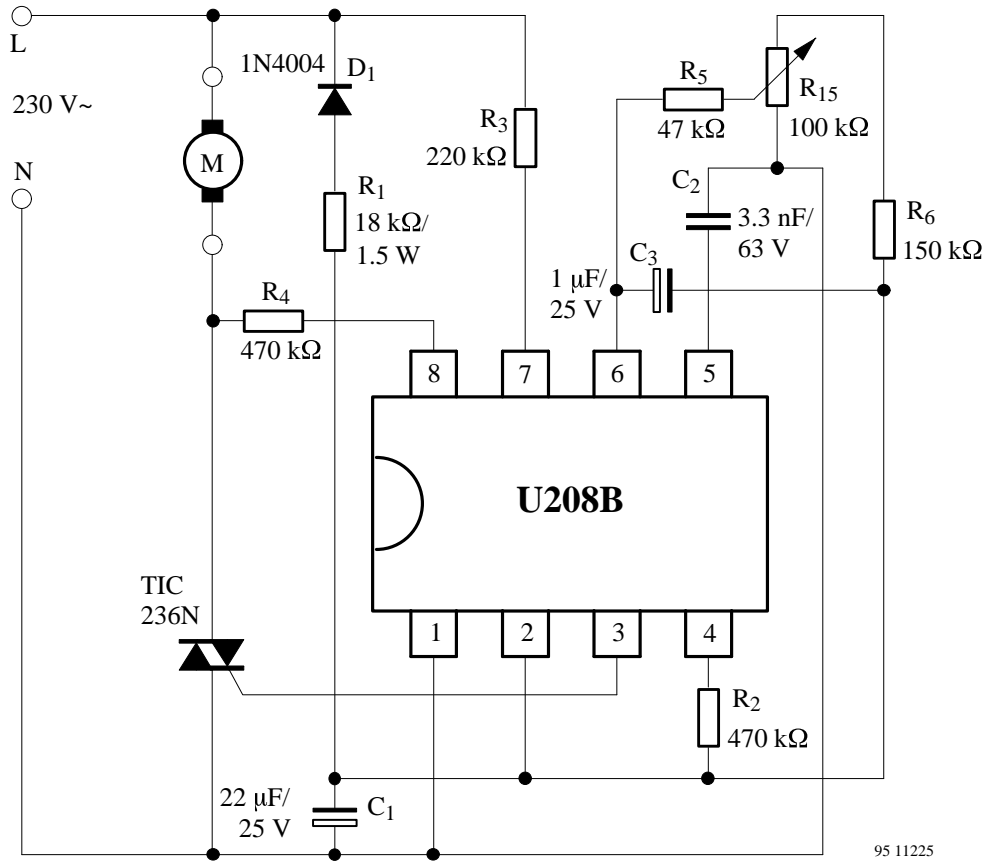
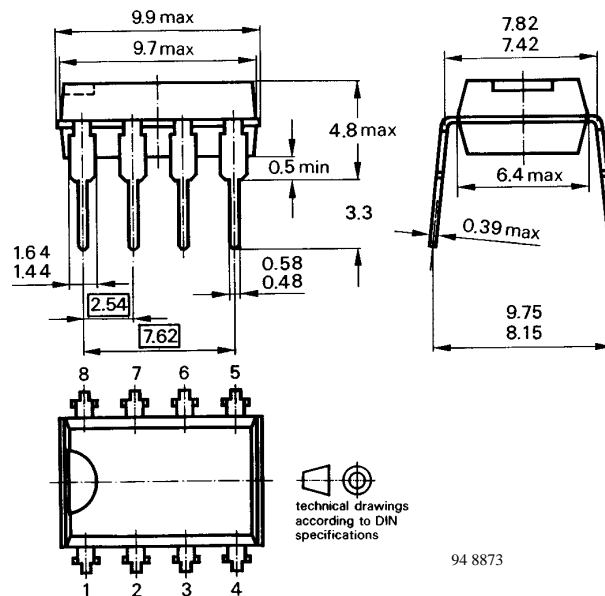

Figure 9. Phase control (power control) for electric tools

Dimensions in mm

Package: DIP8



94 8873

Ozone Depleting Substances Policy Statement

It is the policy of **TEMIC TELEFUNKEN microelectronic GmbH** to

1. Meet all present and future national and international statutory requirements.
2. Regularly and continuously improve the performance of our products, processes, distribution and operating systems with respect to their impact on the health and safety of our employees and the public, as well as their impact on the environment.

It is particular concern to control or eliminate releases of those substances into the atmosphere which are known as ozone depleting substances (ODSs).

The Montreal Protocol (1987) and its London Amendments (1990) intend to severely restrict the use of ODSs and forbid their use within the next ten years. Various national and international initiatives are pressing for an earlier ban on these substances.

TEMIC TELEFUNKEN microelectronic GmbH semiconductor division has been able to use its policy of continuous improvements to eliminate the use of ODSs listed in the following documents.

1. Annex A, B and list of transitional substances of the Montreal Protocol and the London Amendments respectively
2. Class I and II ozone depleting substances in the Clean Air Act Amendments of 1990 by the Environmental Protection Agency (EPA) in the USA
3. Council Decision 88/540/EEC and 91/690/EEC Annex A, B and C (transitional substances) respectively.

TEMIC can certify that our semiconductors are not manufactured with ozone depleting substances and do not contain such substances.

We reserve the right to make changes to improve technical design and may do so without further notice.

Parameters can vary in different applications. All operating parameters must be validated for each customer application by the customer. Should the buyer use TEMIC products for any unintended or unauthorized application, the buyer shall indemnify TEMIC against all claims, costs, damages, and expenses, arising out of, directly or indirectly, any claim of personal damage, injury or death associated with such unintended or unauthorized use.

TEMIC TELEFUNKEN microelectronic GmbH, P.O.B. 3535, D-74025 Heilbronn, Germany
Telephone: 49 (0)7131 67 2831, Fax number: 49 (0)7131 67 2423