

VOLTAGE REGULATOR (with Wide Input Voltage Range) with RESET R1150Hxxxx series

■ OUTLINE

The R1150Hxxxx series are voltage regulator (VR) ICs equipped with a voltage detector (V_{DET}) by CMOS process. VR function of the R1150Hxxxx has features of low dropout voltage, high output voltage accuracy, and ultra-low supply current. Each of the R1150HxxxA types includes also a chip enable circuit. The output of built-in voltage detector is Nch open drain type. The R1150HxxxC/D types have a pin for connecting external capacitor to set a certain reset delay time instead of chip enable control pin.

The regulator output voltage and the detector threshold voltage are fixed in the IC, Output Voltage Accuracy is $\pm 2.0\%$, while Detector Threshold Accuracy is $\pm 2.5\%$. The R1150HxxxA (with chip enable function) and C series can supervise input voltage by the built-in detector. R1150HxxxB type can supervise SENSE pin voltage by the built-in detector. R1150HxxxD type can supervise V_{OUT} voltage, or Regulator Output Voltage of this IC itself.

Since the package for these ICs is the SOT-89-5 package, high density mounting of the ICs on boards is possible.

■ FEATURES

- Ultra-Low Supply Current..... TYP. 7 μ A
- Input Voltage MAX. 24V
- Output Voltage (VR)..... Stepwise setting with a step of 0.1V in the range of 2.1V to 14.0V
- Detector Threshold Voltage (V_{DET})..... Stepwise setting with a step of 0.1V in the range of 2.3V to 15.0V
- High Output Voltage Accuracy..... $\pm 2.0\%$ (VR) $\pm 2.5\%$ (VD)
- Output Current..... MIN. 150mA(V_{OUT}=5V)
- Small Package SOT-89-5
- Built-in Current Limit Circuit, Thermal Shutdown Circuit (VR)
- Monitoring V_{DD} voltage A/C type
 - Monitoring sense pin (_{SENSE}) voltage B type
 - Monitoring V_{OUT} pin voltage D type

■ APPLICATIONS

- Power source and Reset circuit for cameras, videos and mobile telecommunication equipment.
- Power source and Reset circuit for battery-operated equipment.
- Power source and Reset circuit for home appliances.

■ BLOCK DIAGRAMS

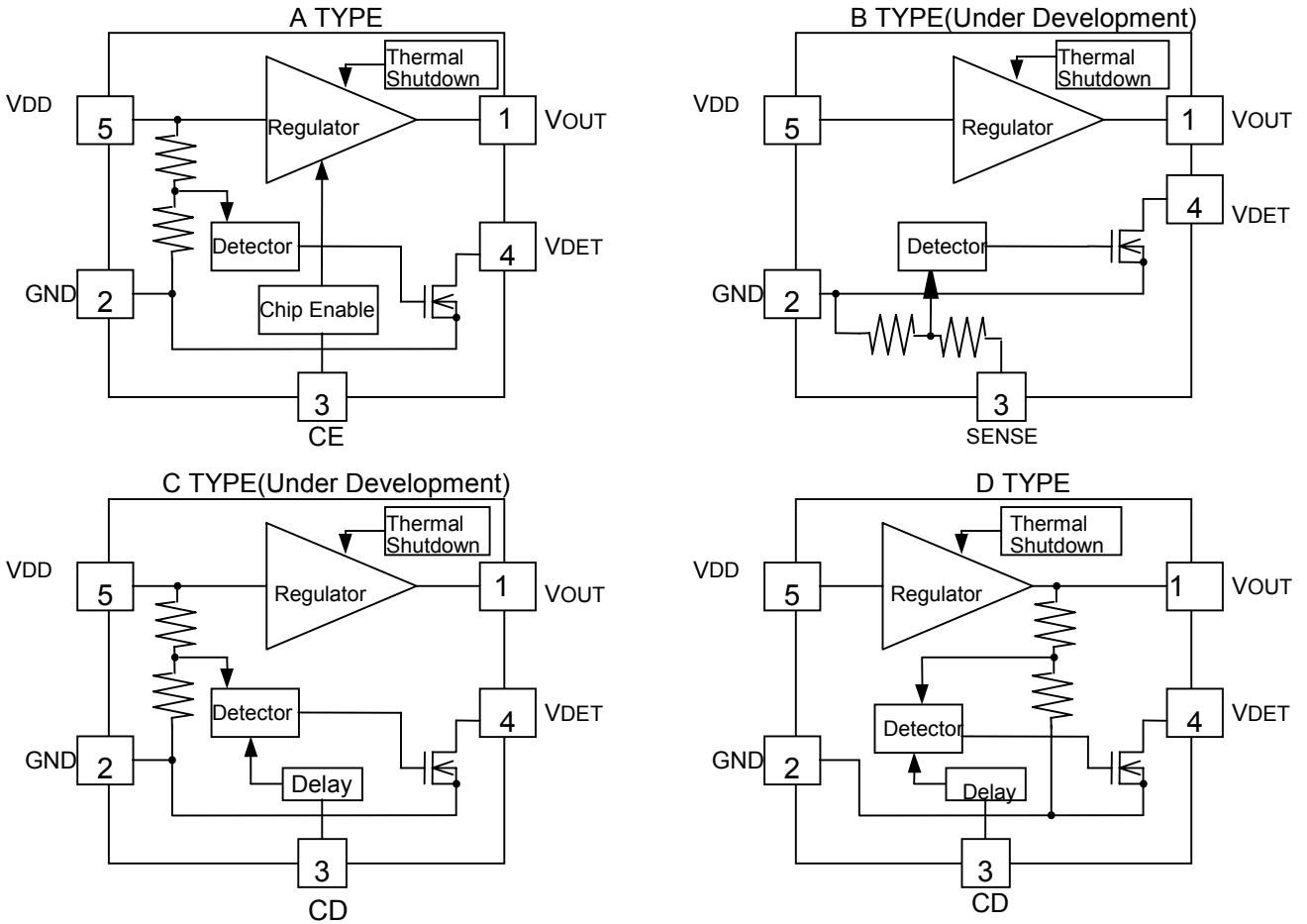

■ SELECTION GUIDE

The output voltage and the usage of pin No.3 (as a kind of types in the R1150Hxxxx series) can be selected at the user's request. The selection can be made with designating the part number as follows;

R1150HXXXX-XX ← Part Number
 ↑ ↑ ↑ ↑
 a b c d

Code	Contents
a	Designation of package type; H : SOT89-5
b	Serial Number for Voltage Setting
c	Designation of option; A: Built-in Chip Enable Circuit (VDET supervises VIN level.) B: VDET supervises SENSE pin. C: Used with an external capacitor for setting output delay time of VDET. (VDET supervises VIN.) D: Used with an external capacitor for setting output delay time of VDET. (VDET supervises VOUT.) B/C versions are under development.
d	Designation of Taping Type; (Refer to Taping Specifications)

■ PIN CONFIGURATION

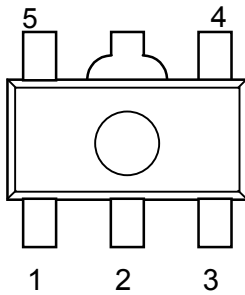

SOT-89-5

■ PIN DESCRIPTION

Pin No.	Symbol	Description
1	VOUT	Voltage Regulator Output Pin
2	GND	Ground Pin
3	CE(A type)	Chip Enable Pin
	SENSE(B type)	Sense Pin for Voltage Detector
	CD(C/D type)	Pin for External Capacitor for Setting Output Delay of Voltage Detector
4	VDET	Voltage Detector Output Pin
5	VDD	Input Pin

■ ABSOLUTE MAXIMUM RATINGS

Item	Symbol	Rating	Unit
Input Voltage	V _{IN}	26.0	V
Input Voltage(CE Input Pin)*Note1	V _{CE}	-0.3 ~ V _{IN} +0.3	V
Input Voltage(SENSE Input Pin)*Note2	V _{SENSE}	-0.3 ~ V _{IN} +0.3	V
Input Voltage(CD Input Pin)*Note3	V _{CD}	-0.3 ~ V _{IN} +0.3	V
Output Voltage(VDET Output Pin)	V _{DET}	-0.3 ~ V _{IN} +0.3	V
Output Voltage	V _{OUT}	-0.3 ~ V _{IN} +0.3	V
Output Current	I _{OUT}	300	mA
Power Dissipation	P _D	Internal Limited	
Operating Temperature	T _{opt}	-40 ~ 85	°C
Storage Temperature	T _{stg}	-55 ~ 125	°C

*Note1: This item is for A Version.

*Note2: This item is for B Version

*Note3: This item is for C/D Version

■ ELECTRICAL CHARACTERISTICS

●R1150HxxxA

(T_{opt}=25°C)

Item	Symbol	Conditions	MIN.	TYP.	MAX.	Unit
Input Voltage	V _{IN}				24.0	V
Supply Current 1	I _{SS1}	V _{IN} =V _{CE} V _{OUT} ≥(-V _{DET}): V _{IN} -V _{OUT} =2.0V V _{OUT} <(-V _{DET}): V _{IN} =(-V _{DET})+2.0V		7	14	μA
Supply Current 2	I _{SS2}	V _{DD} =24V, V _{CE} =0V	Refer to Supply Current 2 Table			
Thermal Shutdown Temperature	T _{SD}	Junction Temperature		150		°C
Thermal Shutdown Released Temperature	T _{SR}	Junction Temperature		120		°C

VR part

(T_{opt}=25°C)

Item	Symbol	Conditions	MIN.	TYP.	MAX.	Unit
Output voltage	V _{OUT}	V _{IN} -V _{OUT} =2.0V I _{OUT} =20mA	x0.98		x1.02	V
Output Current	I _{OUT}	V _{IN} -V _{OUT} =2.0V	Refer to Output Current Table			
Load Regulation	ΔV _{OUT} / ΔI _{OUT}	V _{IN} -V _{OUT} =2.0V 1mA≤I _{OUT} ≤40mA	Refer to Load Regulation Table			
Line Regulation	ΔV _{OUT} / ΔV _{IN}	V _{IN} -V _{OUT} =2.0V I _{OUT} =20mA V _{OUT} +1V≤V _{IN} ≤24V		0.05	0.15	%/V
Dropout Voltage	V _{DIF}	I _{OUT} =20mA	Refer to Dropout Voltage Table			
Output Voltage Temperature Coefficient	ΔV _{OUT} / ΔT	V _{IN} -V _{OUT} =2.0V I _{OUT} =20mA -40°C ≤ T _{opt} ≤ 85°C		±100		ppm /°C
Short Current Limit	I _{LIM}	V _{OUT} =0V		45		mA
CE "H" Input Voltage	V _{CEH}		1.5		V _{IN}	V
CE "L" Input Voltage	V _{CEL}		0		0.25	V

V_{DET} part

(T_{opt}=25°C)

Item	Symbol	Conditions	MIN.	TYP.	MAX.	Unit
Detector Threshold	-V _{DET}		x0.975		x1.025	V
Detector Threshold Hysteresis	V _{HYS}		-V _{DET} x0.03	-V _{DET} x0.05	-V _{DET} x0.07	V
Sink Current	I _{DOUT}	V _{IN} =2.0V, V _{DET} =0.05V	0.15	0.20		μA
Minimum Operating Voltage	V _{DDL}	*Note 1		0.9	1.2	V
Detector Threshold Temperature Coefficient	Δ(-V _{DET})/ ΔT	-40°C≤T _{opt} ≤85°C		±100		ppm /°C
Output Delay Time	t _{PLH}	*Note 2		0.5	1.0	ms

●R1150HxxxB

(T_{opt}=25°C)

Item	Symbol	Conditions	MIN.	TYP.	MAX.	Unit
Input Voltage	V _{IN}				24.0	V
Supply Current	I _{SS}	V _{OUT} ≥ (-V _{DET}): V _{IN} = SENSE = V _{OUT} + 2.0V V _{OUT} < (-V _{DET}): V _{IN} = SENSE = (-V _{DET}) + 2.0V		7	14	μA
Thermal Shutdown Temperature	T _{SD}	Junction Temperature		150		°C
Thermal Shutdown Released Temperature	T _{SR}	Junction Temperature		120		°C

VR part

(T_{opt}=25°C)

Item	Symbol	Conditions	MIN.	TYP.	MAX.	Unit
Output voltage	V _{OUT}	V _{IN} - V _{OUT} = 2.0V I _{OUT} = 20mA	V _{SET} x0.98	V _{SET}	V _{SET} x1.02	V
Output Current	I _{OUT}	V _{IN} - V _{OUT} = 2.0V	Refer to Output Current Table			
Load regulation	ΔV _{OUT} / ΔI _{OUT}	V _{IN} - V _{OUT} = 2.0V 1mA ≤ I _{OUT} ≤ 40mA	Refer to Load Regulation Table			
Line regulation	ΔV _{OUT} / ΔV _{IN}	I _{OUT} = 20mA V _{OUT} + 1V ≤ V _{IN} ≤ 24V		0.05	0.15	%/V
Dropout Voltage	V _{DIF}	I _{OUT} = 20mA	Refer to Dropout Voltage Table			
Output Voltage Temperature Coefficient	ΔV _{OUT} / ΔT	V _{IN} - V _{OUT} = 2.0V I _{OUT} = 20mA -40°C ≤ T _{opt} ≤ 85°C		±100		ppm /°C
Short Current Limit	I _{LIM}	V _{OUT} = 0V		45		mA

V_{DET} part

(T_{opt}=25°C)

Item	Symbol	Conditions	MIN.	TYP.	MAX.	Unit
Detector Threshold	-V _{DET}		V _{SET} x0.975	V _{SET}	V _{SET} x1.025	V
Detector Threshold Hysteresis	V _{HYS}		-V _{DET} x0.03	-V _{DET} x0.05	-V _{DET} x0.07	V
Sink Current	I _{DOUT}	V _{IN} = SENSE = 2.0V, V _{DS} = 0.05V	0.17			mA
Minimum Operating Voltage	V _{DDL}	*Note 1		0.9	1.2	V
Detector Threshold Temperature Coefficient	Δ(-V _{DET})/ ΔT	-40°C ≤ T _{opt} ≤ 85°C		±100		ppm /°C
Output Delay Time	t _{PLH}	*Note 2		1.0	1.5	ms

●R1150HxxxC

(T_{opt}=25°C)

Item	Symbol	Conditions	MIN.	TYP.	MAX.	Unit
Input voltage	V _{IN}				24.0	V
Supply Current	I _{SS}	V _{OUT} ≥ (-V _{DET}): V _{IN} = V _{OUT} + 2.0V V _{OUT} < (-V _{DET}): V _{IN} = (-V _{DET}) + 2.0V		7	14	μA
Thermal Shutdown Temperature	T _{SD}	Junction Temperature		150		°C
Thermal Shutdown Released Temperature	T _{SR}	Junction Temperature		120		°C

VR part

(T_{opt}=25°C)

Item	Symbol	Conditions	MIN.	TYP.	MAX.	Unit
Output Voltage	V _{OUT}	V _{IN} =V _{OUT} +2V, I _{OUT} =20mA	V _{SET} x0.98	V _{SET}	V _{SET} x1.02	V
Output Current	I _{OUT}	V _{IN} -V _{OUT} =2.0V	Refer to Output Current Table			
Load regulation	$\frac{\Delta V_{OUT}}{\Delta I_{OUT}}$	V _{IN} -V _{OUT} =2.0V 1mA≤I _{OUT} ≤40mA	Refer to Load Regulation Table			
Line regulation	$\frac{\Delta V_{OUT}}{\Delta V_{IN}}$	I _{OUT} =20mA V _{OUT} +1V≤V _{IN} ≤24V		0.05	0.15	%/V
Dropout Voltage	V _{DIF}	I _{OUT} =20mA	Refer to Dropout Voltage Table			
Output Voltage Temperature Coefficient	$\frac{\Delta V_{OUT}}{\Delta T}$	V _{IN} -V _{OUT} =2.0V I _{OUT} =20mA -40°C≤T _{opt} ≤85°C		±100		ppm /°C
Short Current Limit	I _{LIM}	V _{OUT} =0V		45		mA

VDET part

(T_{opt}=25°C)

Item	Symbol	Conditions	MIN.	TYP.	MAX.	Unit
Detector Threshold	-V _{DET}		V _{SET} x0.975	V _{SET}	V _{SET} x1.025	V
Detector Threshold Hysteresis	V _{HYS}		-V _{DET} x0.03	-V _{DET} x0.05	-V _{DET} x0.07	V
Sink Current	I _{DOU} T	V _{IN} =2.0V, V _{DS} =0.05V	0.17			mA
Minimum Operating Voltage	V _{DDL}	*Note 1		0.9	1.2	V
Detector Threshold Temperature Coefficient	$\frac{\Delta -V_{DET}}{\Delta T}$	-40°C ≤ T _{opt} ≤ 85°C		±100		ppm /°C
Output Delay Time	t _{PLH}	C _d =4.7nF, *Note 2	20	30	50	ms

●R1150HxxxD

(T_{opt}=25°C)

Item	Symbol	Conditions	MIN.	TYP.	MAX.	Unit
Input Voltage	V _{IN}				24.0	V
Supply Current	I _{SS}	V _{IN} -V _{OUT} =2.0V		7	14	μA
Thermal Shutdown Temperature	T _{SD}			150		°C
Thermal Shutdown Released Temperature	T _{SR}	Junction Temperature		120		°C

VR part

(T_{opt}=25°C)

Item	Symbol	Conditions	MIN.	TYP.	MAX.	Unit
Output voltage	V _{OUT}	V _{IN} -V _{OUT} =2.0V I _{OUT} =20mA	V _{SET} x0.98	V _{SET}	V _{SET} x1.02	V
Output Current	I _{OUT1}	V _{IN} -V _{OUT} =2.0V	Refer to Output Current Table			
Load regulation	$\frac{\Delta V_{OUT}}{\Delta I_{OUT}}$	V _{IN} -V _{OUT} =2.0V 1mA≤I _{OUT} ≤40mA	Refer to Load Regulation Table			
Line regulation	$\frac{\Delta V_{OUT}}{\Delta V_{IN}}$	I _{OUT} =20mA V _{OUT} +1V≤V _{IN} ≤24V		0.05	0.15	%/V
Output Voltage Temperature Coefficient	$\frac{\Delta V_{OUT}}{\Delta T}$	V _{IN} -V _{OUT} =2.0V I _{OUT} =20mA -40°C ≤ T _{opt} ≤ 85°C		±100		ppm /°C
Short Current Limit	I _{LIM}	V _{OUT} =0V		45		mA

VDET part		(T _{opt} =25°C)				
Item	Symbol	Conditions	MIN.	TYP.	MAX.	Unit
Detector Threshold	-VDET		VSET x0.975	VSET	VSET x1.025	V
Detector Threshold Hysteresis	VHYS		-VDET x0.03	-VDET x0.05	-VDET x0.07	V
Sink Current	IDOUT	V _{IN} =2.0V, V _{DS} =0.05V	0.17			mA
Minimum Operating Voltage	VDDL	*Note 1		0.9	1.2	V
Detector Threshold Temperature Coefficient	$\frac{\Delta-VDET}{\Delta T}$	-40°C ≤ T _{opt} ≤ 85°C		±100		ppm /°C
Output Delay Time	t _{PD}	C _d =4.7nF, *Note 2	20	30	50	ms
Release Margin		V _{OUT} -0.2(-VDET)- VHYS	50			mV

Note 1) This item means VDD Voltage when Output Voltage is equal or less than 0.1V(Pull-up Resistor=470kΩ, Pull up Voltage=5V)

Note 2) VDET pin is pulled up to VDD via 470kΩ. t_{PLH} means time interval from rising edge of VDD from (-VDET)-2.0V to (-VDET)+2.0V to the point of Output Voltage being 80% of pull-up voltage.

●Output Current (T_{opt}=25°C)

Output Voltage V _{OUT} (V)	Output Current (mA)	
	MIN.	
2.1V ≤ V _{OUT} ≤ 2.9V	90	
3.0V ≤ V _{OUT} ≤ 4.0V	120	
4.1V ≤ V _{OUT} ≤ 14V	150	

●Load Regulation (T_{opt}=25°C)

Output Voltage V _{OUT} (V)	Load Regulation (mV)	
	TYP.	MAX.
2.1V ≤ V _{OUT} ≤ 3.0V	15	35
3.1V ≤ V _{OUT} ≤ 5.0V	25	45
5.1V ≤ V _{OUT} ≤ 10.0V	40	65
10.1V ≤ V _{OUT} ≤ 14.0V	50	80

●Dropout Voltage (T_{opt}=25°C)

Output Voltage V _{OUT} (V)	Dropout Voltage (V)	
	TYP.	MAX.
2.1V ≤ V _{OUT} ≤ 2.4V	0.40	0.60
2.5V ≤ V _{OUT} ≤ 3.0V	0.30	0.40
3.1V ≤ V _{OUT} ≤ 7.0V	0.25	0.35
7.1V ≤ V _{OUT} ≤ 10.0V	0.27	0.45
10.1V ≤ V _{OUT} ≤ 14.0V	0.30	0.50

●Supply Current 2(Off state with CE) (Topt=25°C)

Detector Threshold Voltage -VDET(V)	Supply Current(μA)	
	TYP.	MAX.
2.3V≤(-VDET)≤3.0V	2.5	5.0
3.1V≤(-VDET)≤15.0V	3.0	6.0

■ TEST CIRCUITS

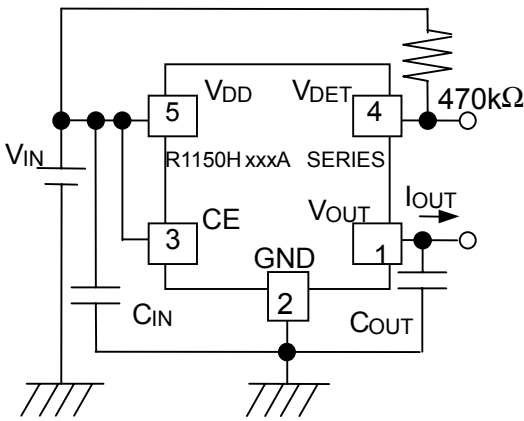

CIN=0.1μF,COUT=1μF

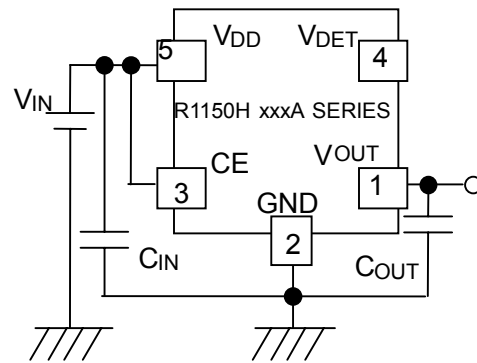

CIN=0.1μF,COUT=1μF

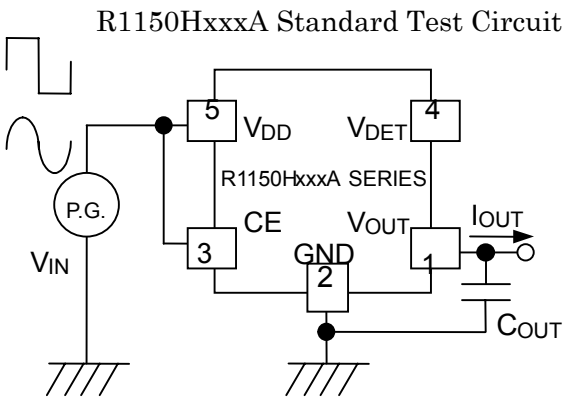

CIN=0.1μF,COUT=1μF

R1150HxxxA Input Transient Response /
Ripple Rejection Test Circuit

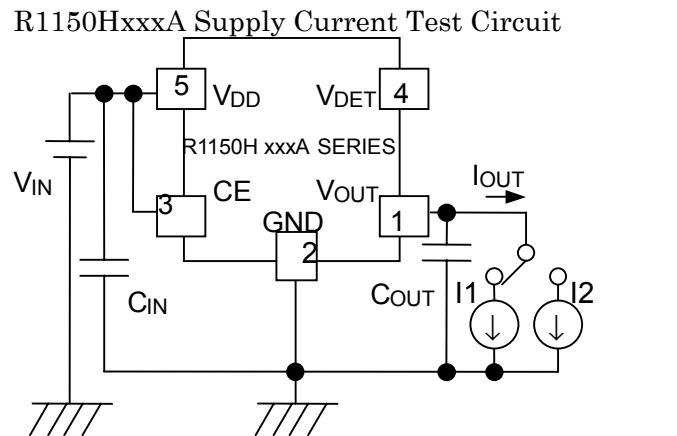

CIN=0.1μF,COUT=1μF

R1150HxxxA Load Transient Response
Test Circuit

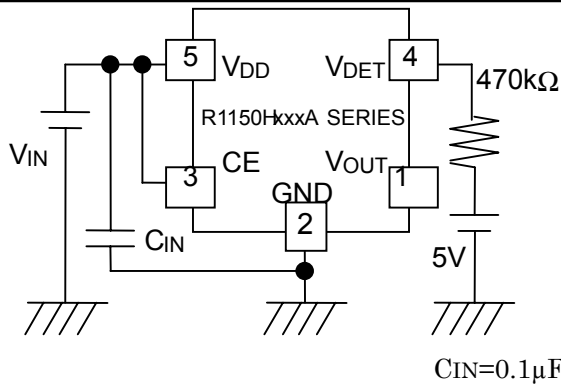

R1150HxxxA Minimum Operating Voltage Test Circuit

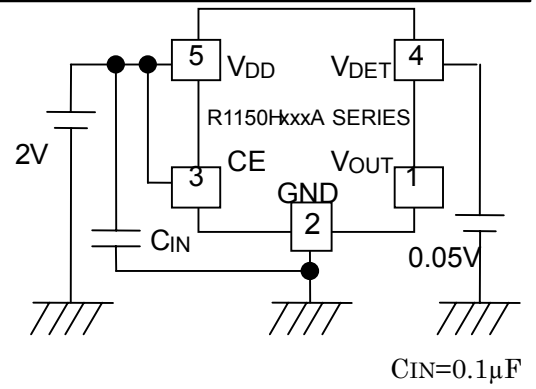

R1150HxxxA VDET Output Current Test Circuit

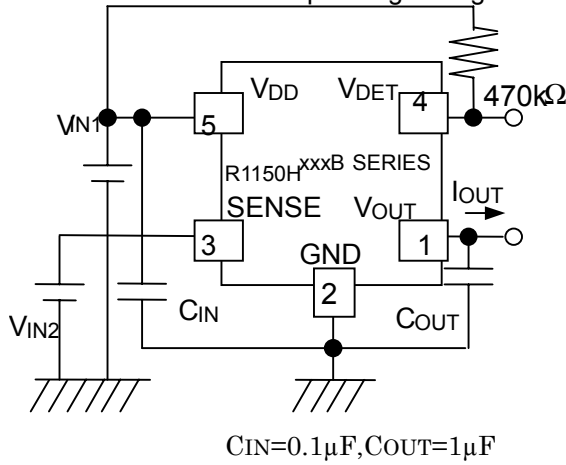

R1150HxxxB Standard Test Circuit

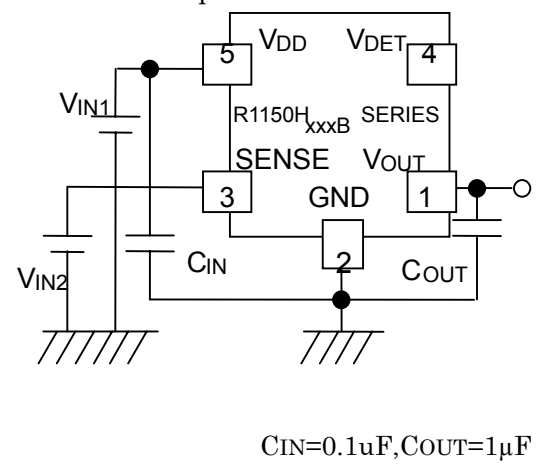

R1150HxxxA VDET Output Current Test Circuit

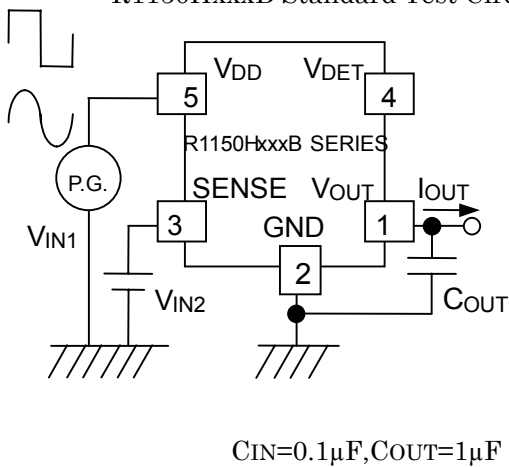

R1150HxxxB Input Transient Response, Ripple Rejection Test Circuit

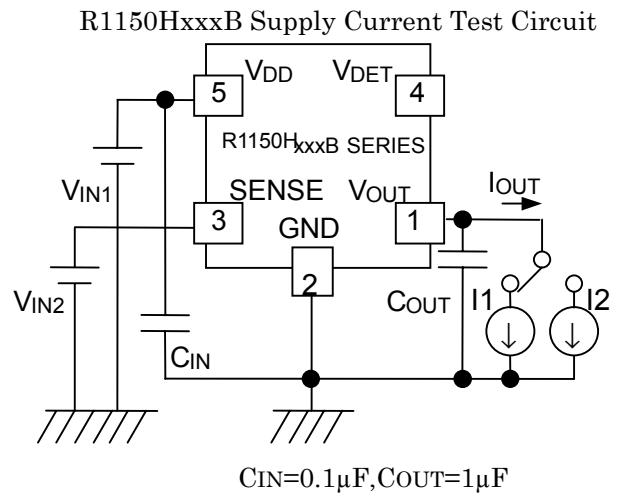

R1150HxxxB Load Transient Response Test Circuit

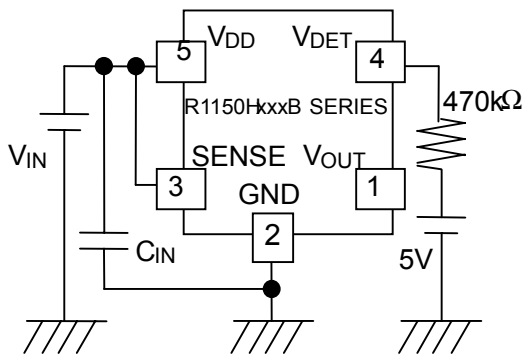

$C_{IN}=0.1\mu F$

R1150HxxxB VDET Minimum Operating Voltage

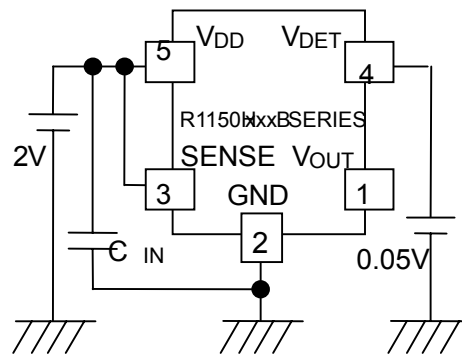

$C_{IN}=0.1\mu F$

R1150HxxxB VDET Output Current Test Circuit

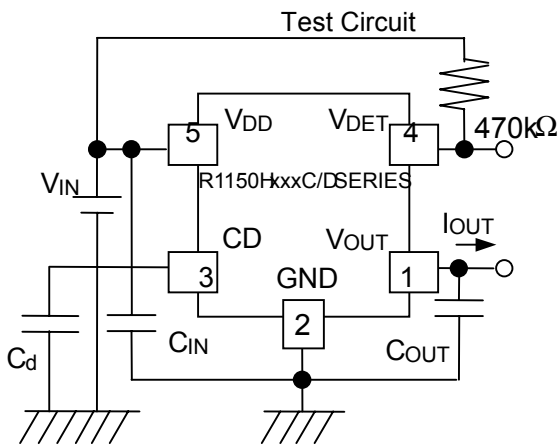

$C_{IN}=0.1\mu F, C_{OUT}=1\mu F$

R1150HxxxC/D Standard Test Circuit

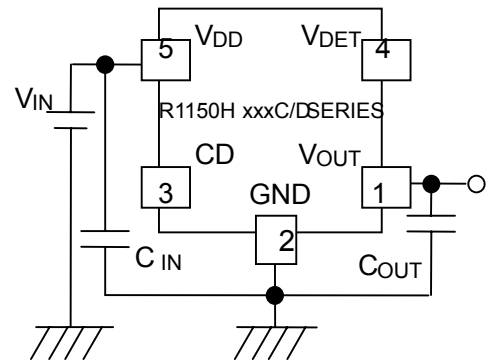

$C_{IN}=0.1\mu F, C_{OUT}=1\mu F$

R1150HxxxC/D Supply Current Test Circuit

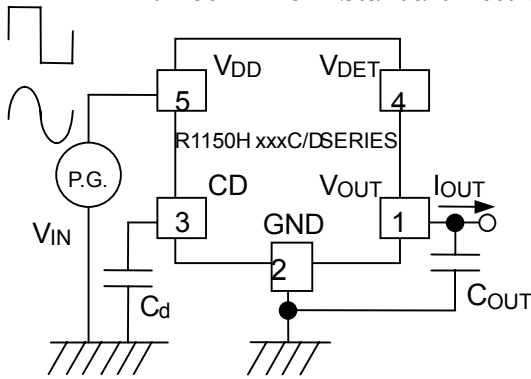

$C_{IN}=0.1\mu F, C_{OUT}=1\mu F$

R1150HxxxC/D Input Transient Response
/ Ripple Rejection Test Circuit

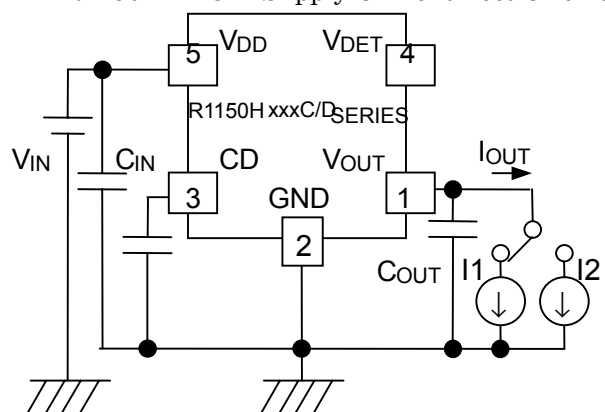

$C_{IN}=0.1\mu F, C_{OUT}=1\mu F$

R1150HxxxC/D Load Transient Response
Test Circuit

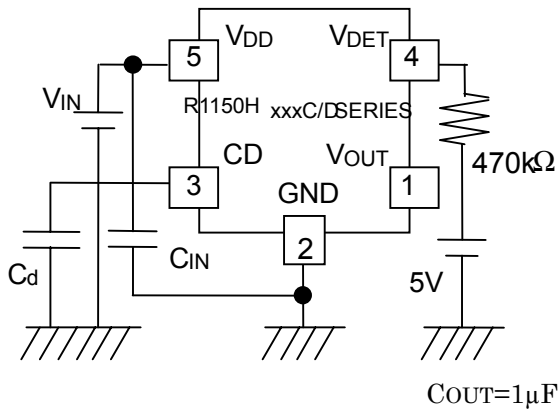

R1150HxxxC/D VDET Minimum Operating Voltage Test Circuit

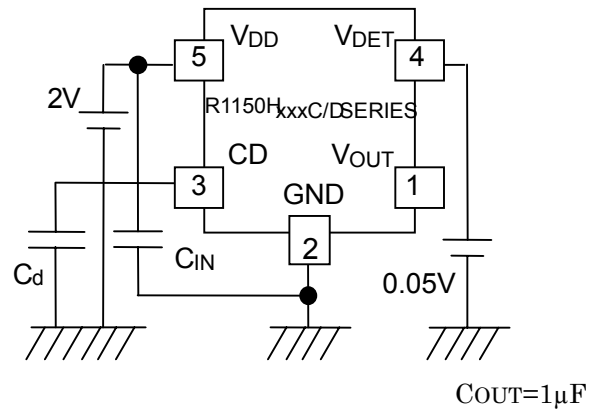

R1150HxxxC/D VDET Output Current Test Circuit

TYPICAL CHARACTERISTICS

1) Output Voltage vs. Temperature

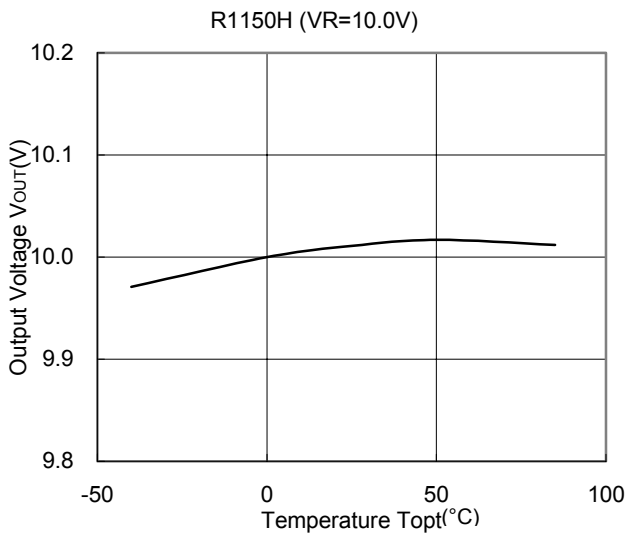
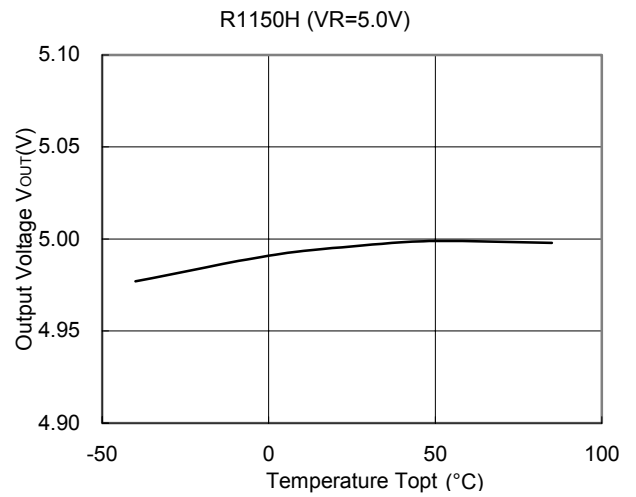
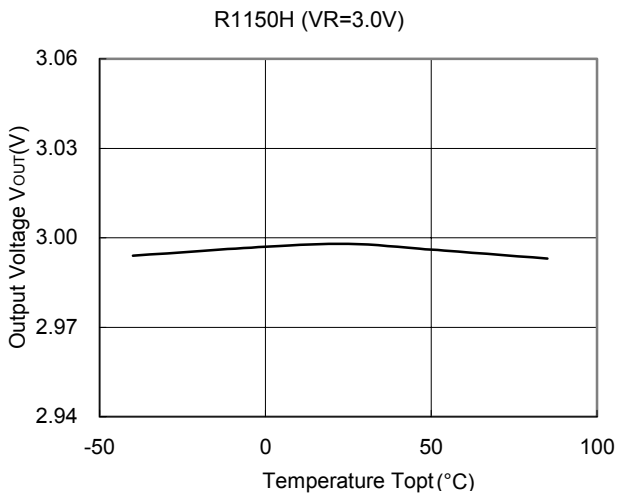

2) Input Voltage vs. Output Voltage (T_{opt}=25°C)

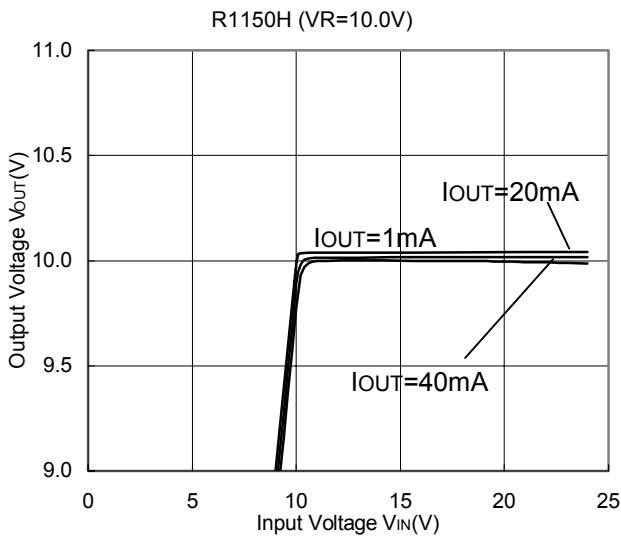
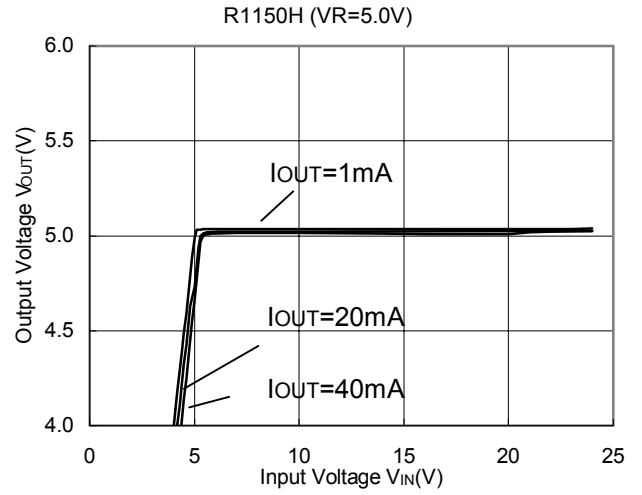
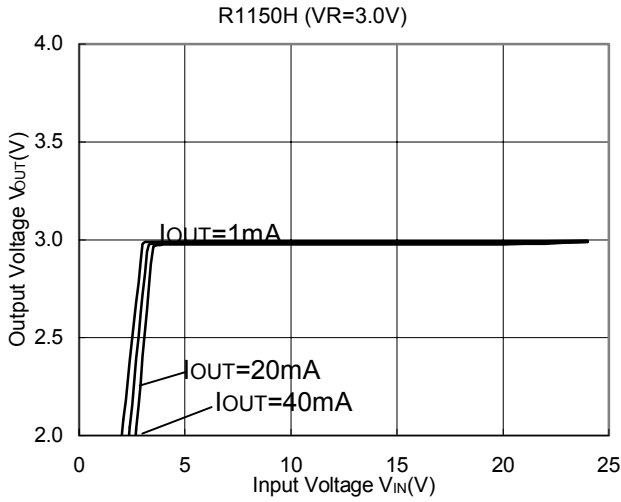

3) Output Voltage vs. Output Current (T_{opt}=25°C)

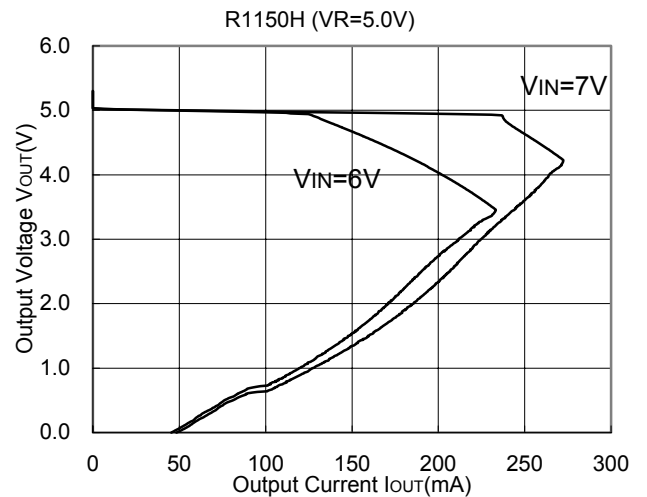
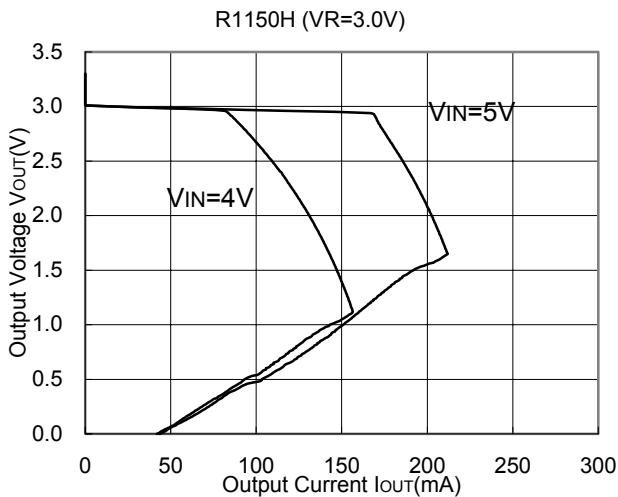

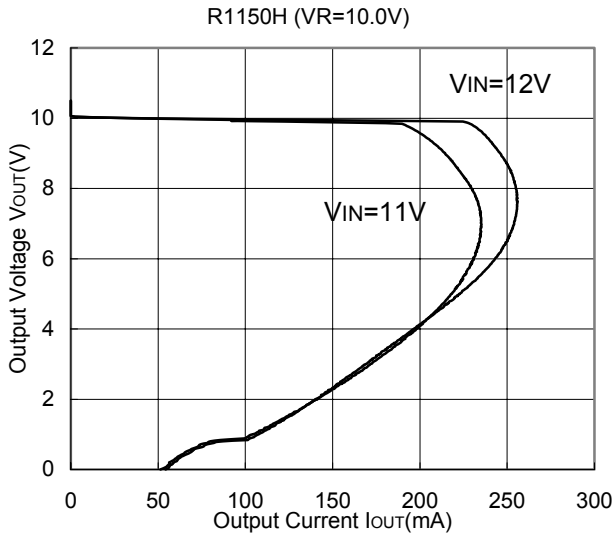

4) Dropout Voltage vs. Output Current

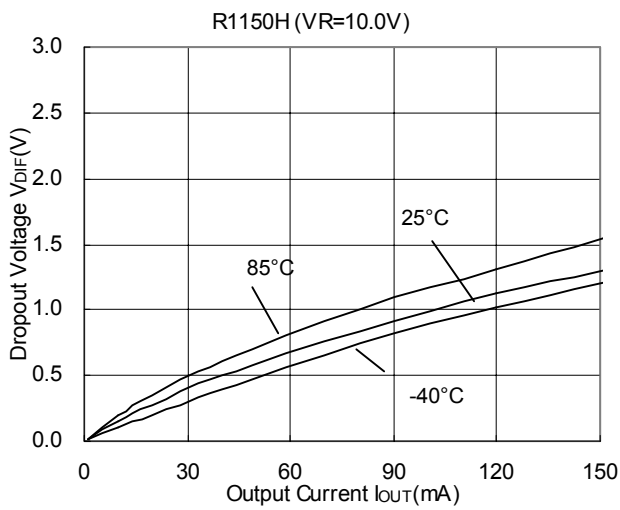
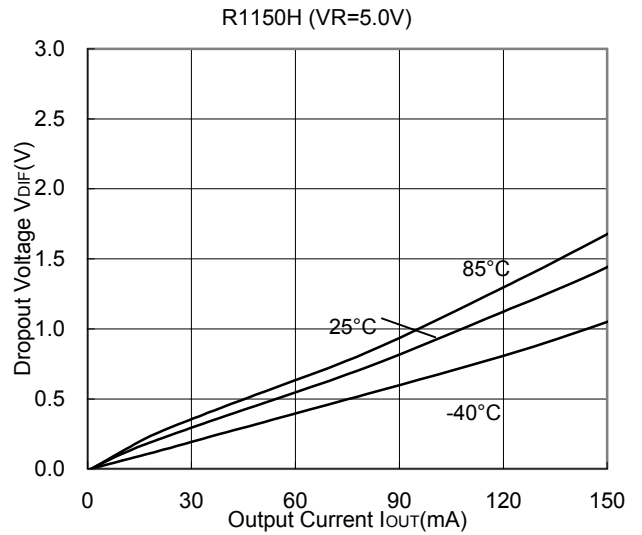
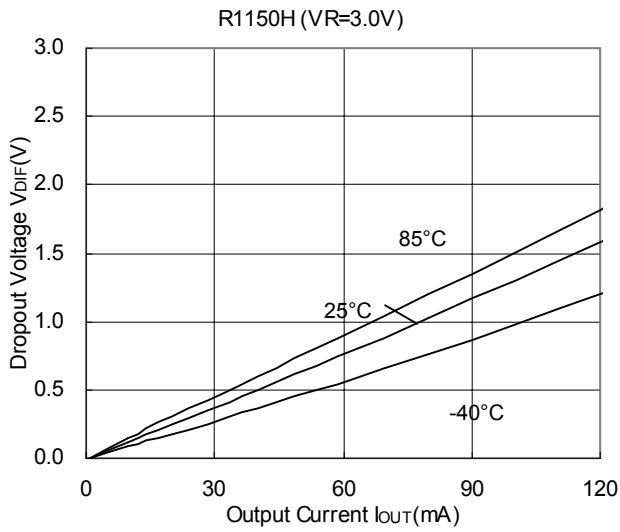

5) Supply Current vs. Input Voltage ($T_{opt}=25^{\circ}\text{C}$)

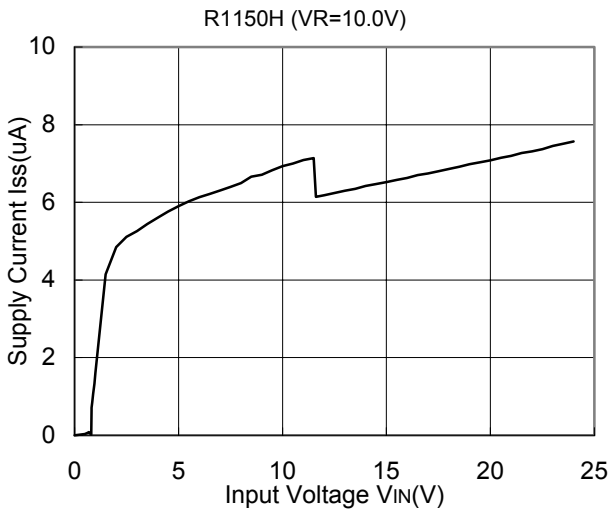
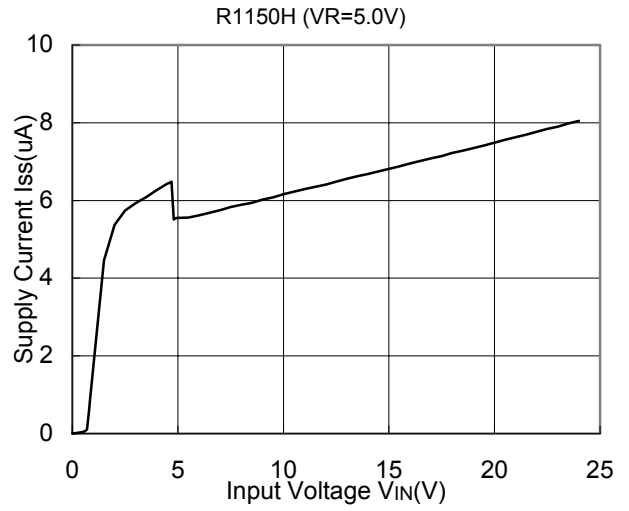
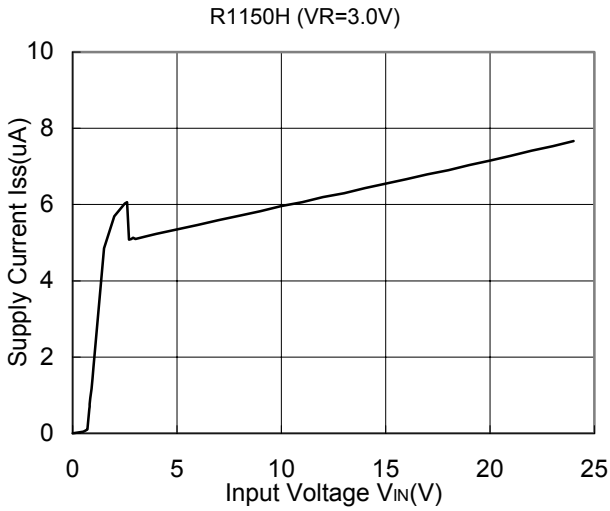

6) Supply Current vs. Temperature

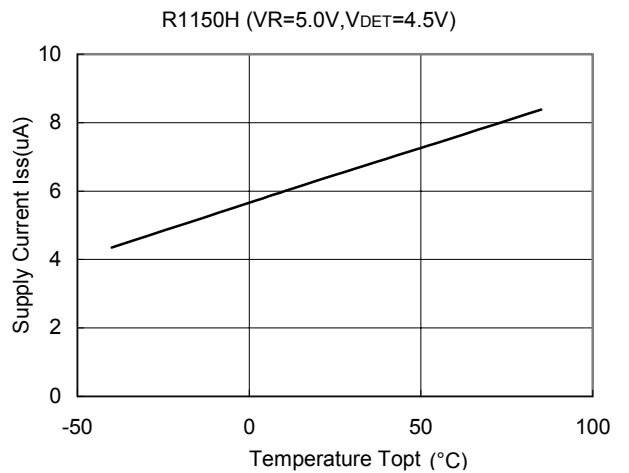
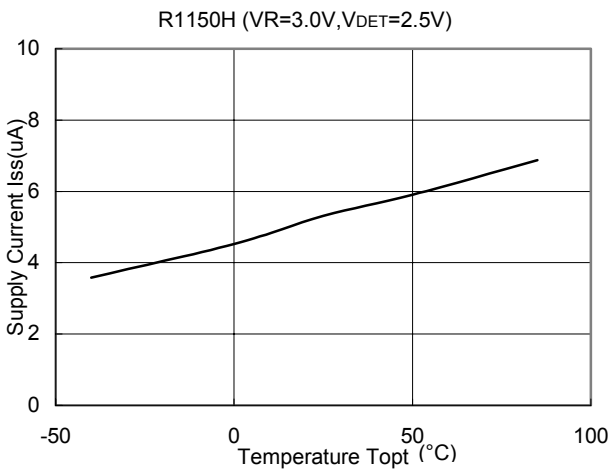

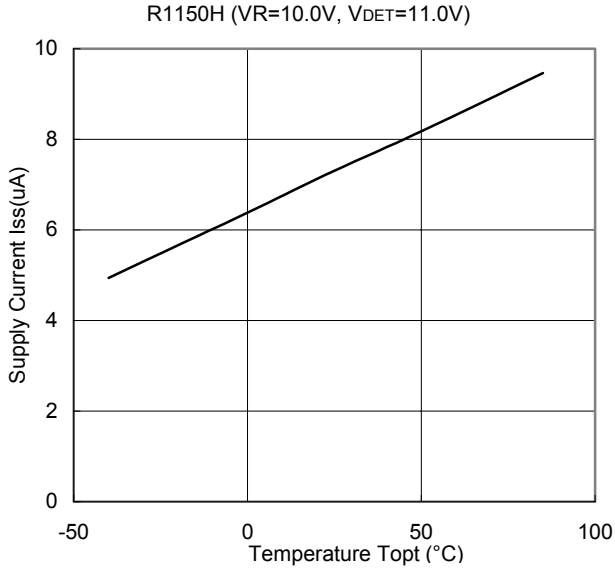

7) Ripple Rejection vs. Frequency (T_{opt}=25°C)

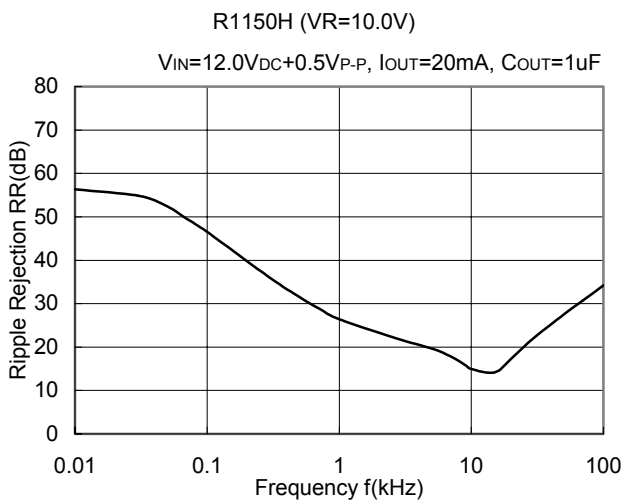
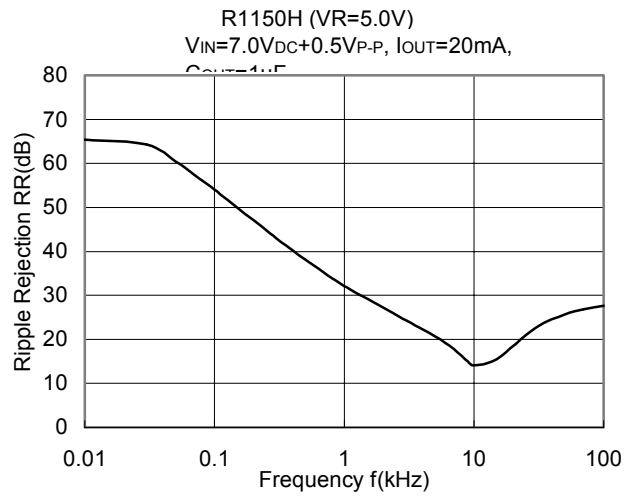
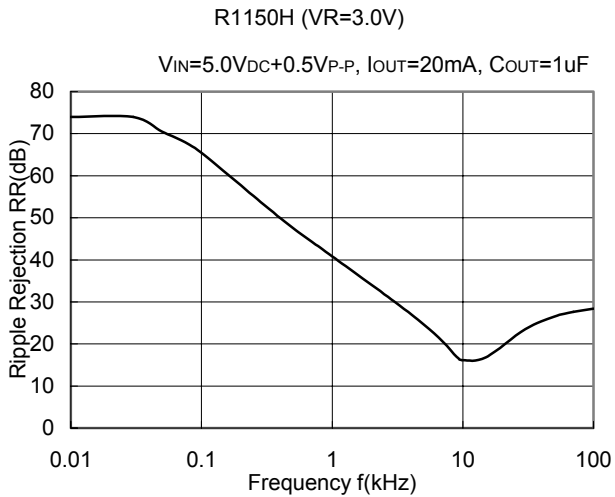

8) Input Transient Response

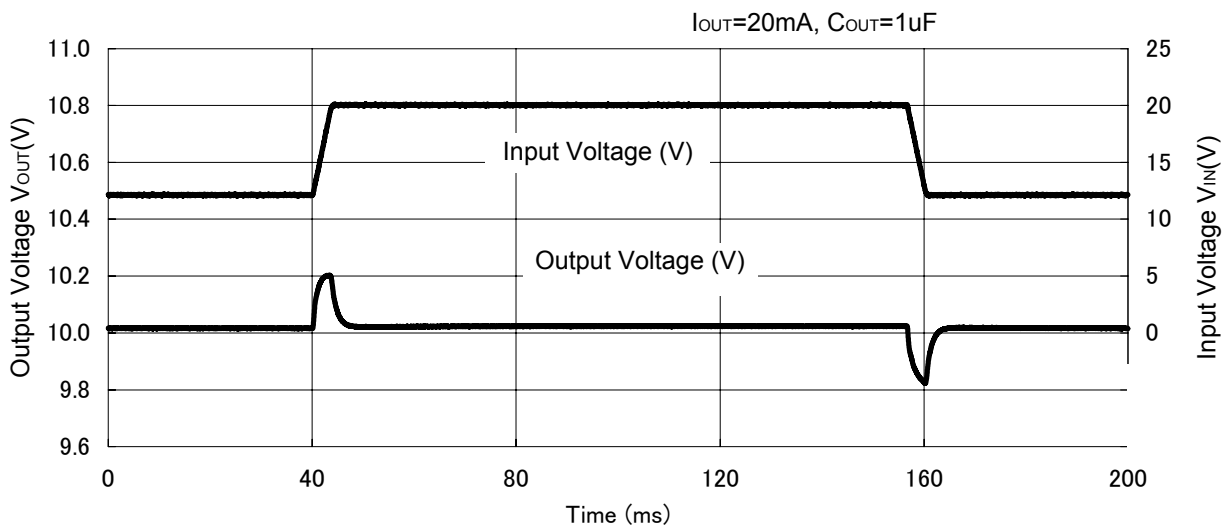
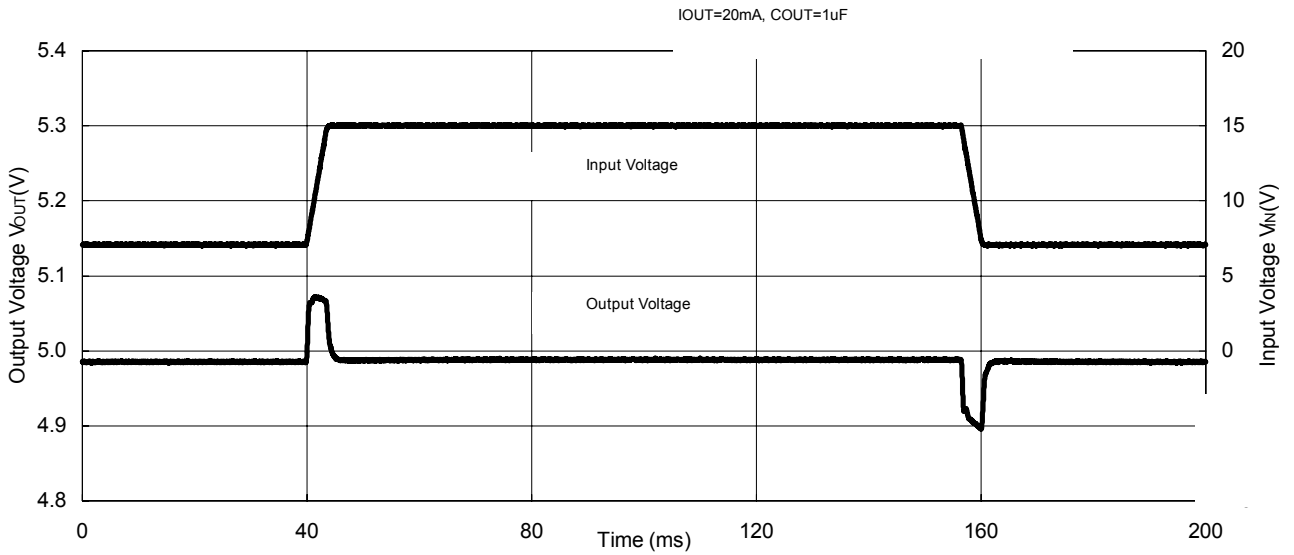
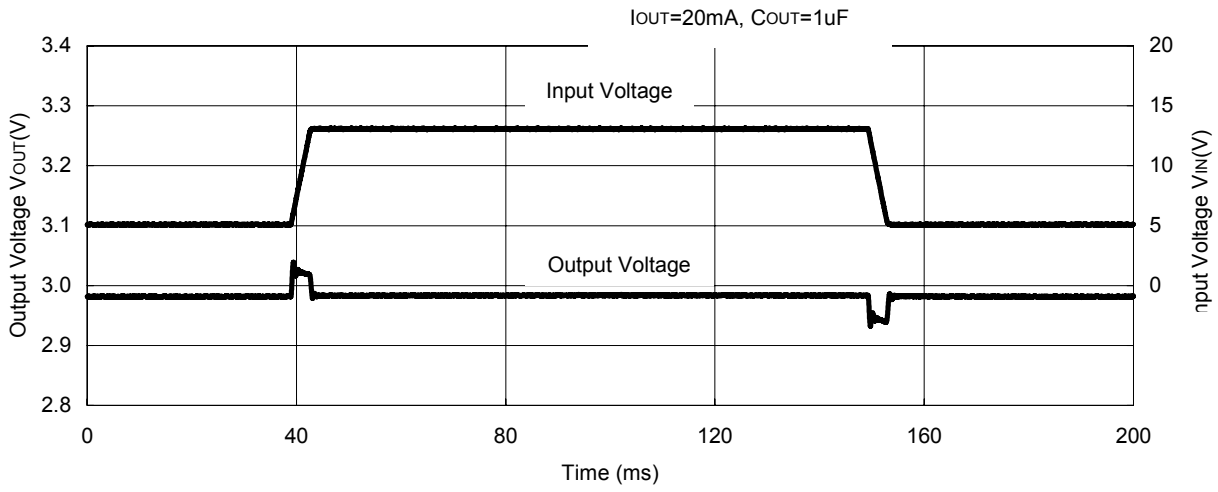

9) Load Transient Response (T_{opt}=25°C)

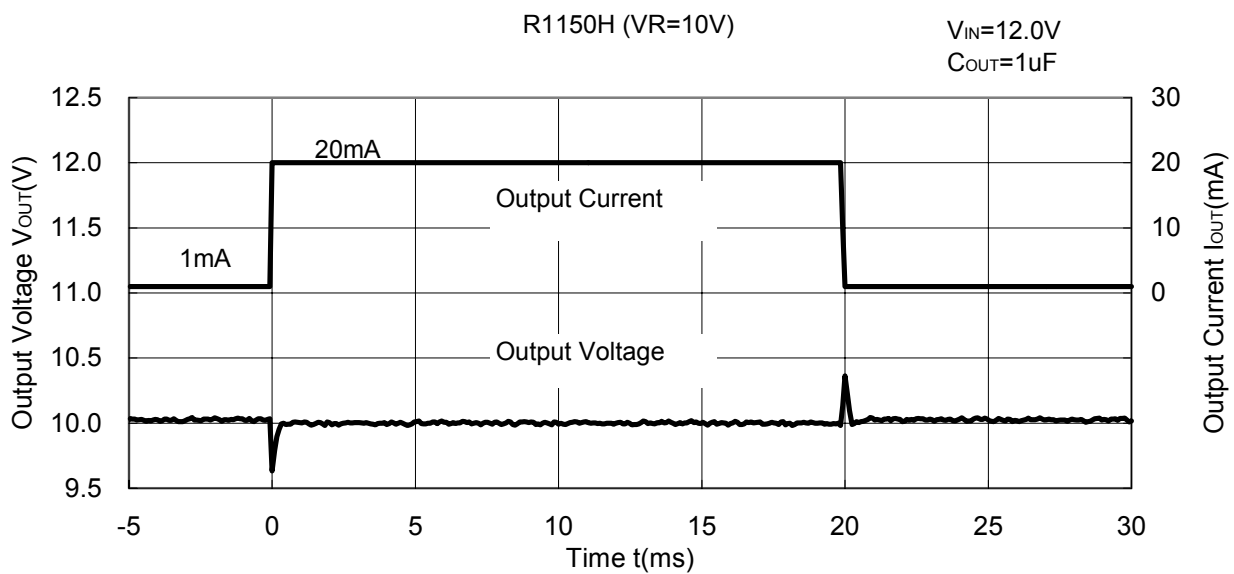
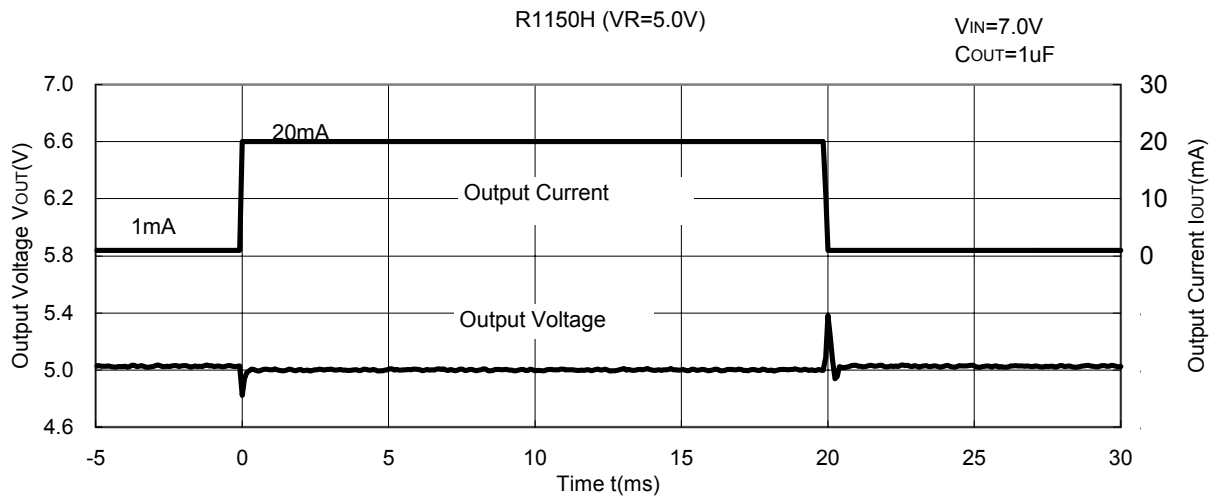
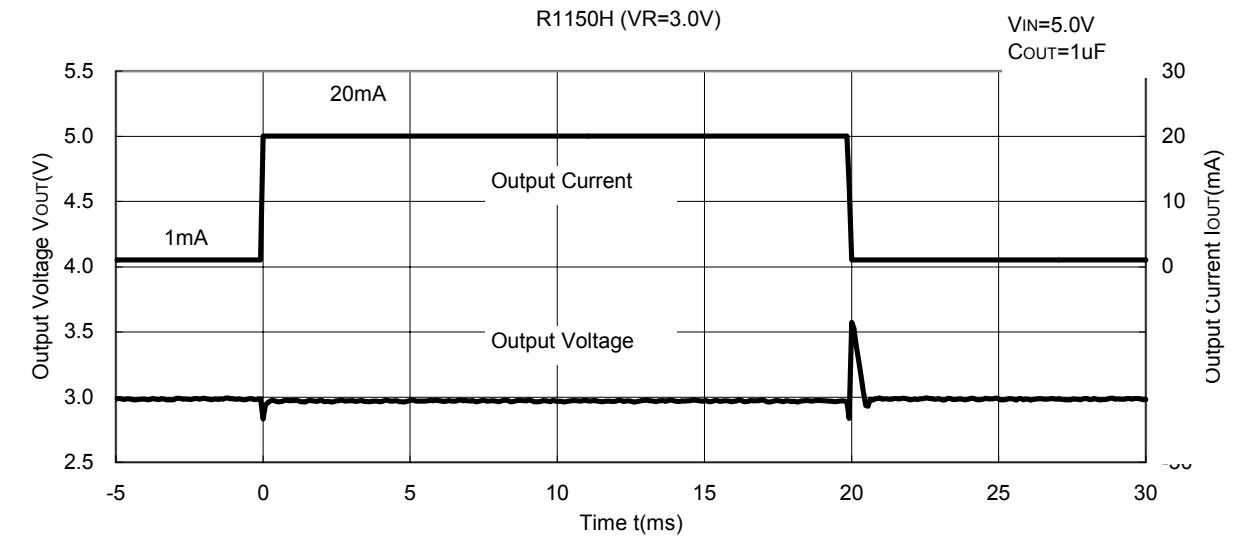

10) Detector Threshold vs. Temperature

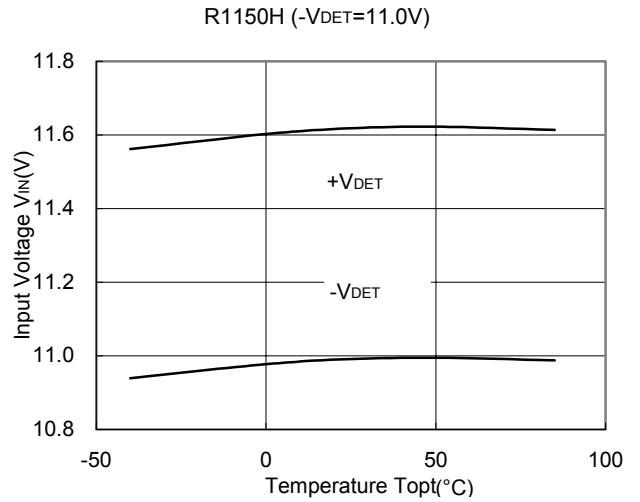
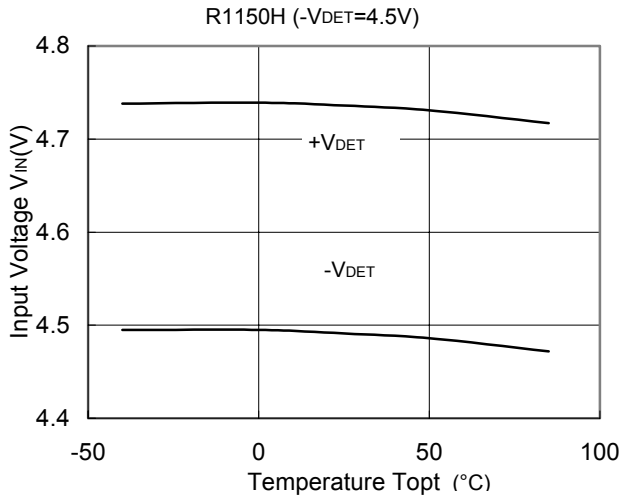

11) Detector Threshold vs. Input Voltage

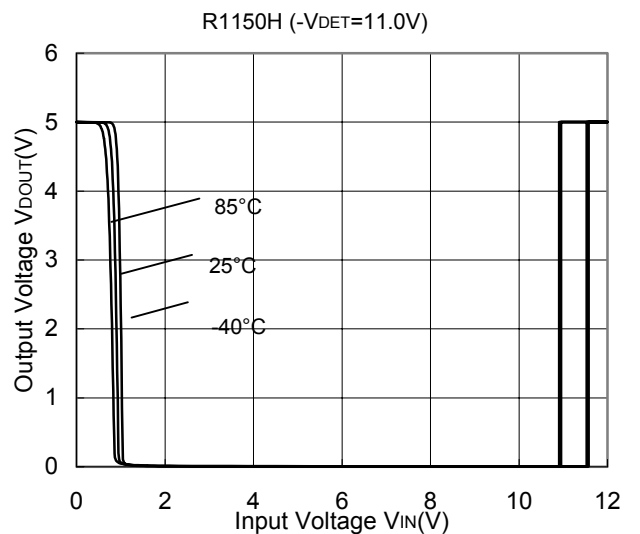
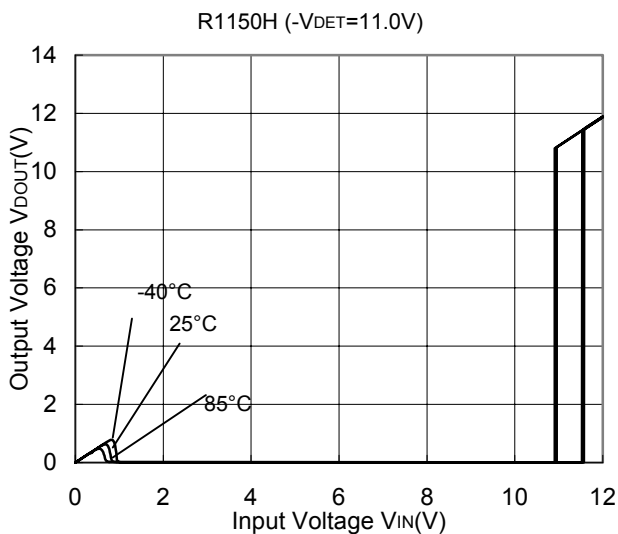
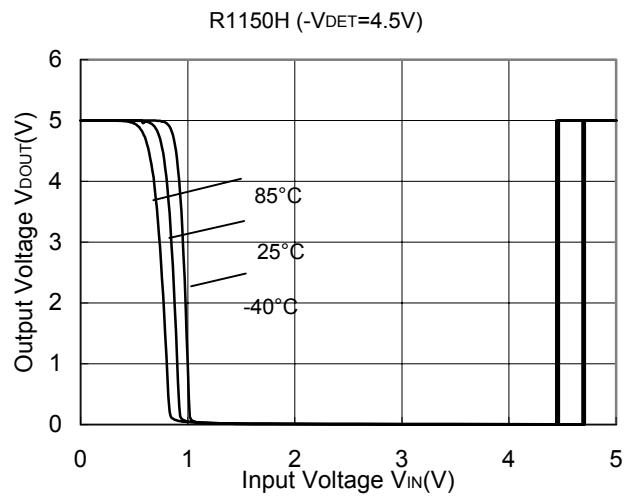
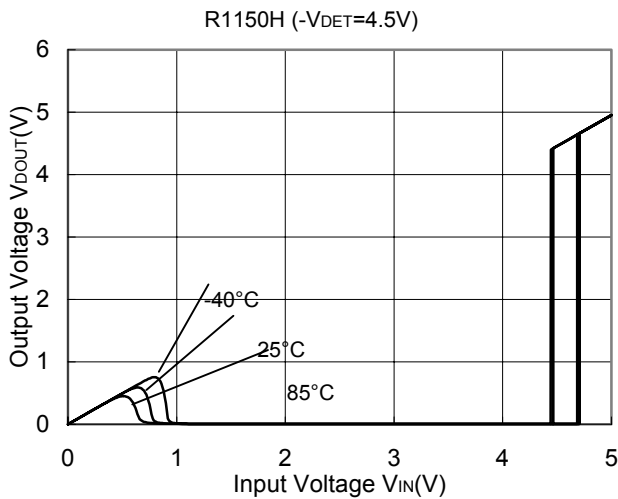

12) Nch Driver Output Current vs. VDS

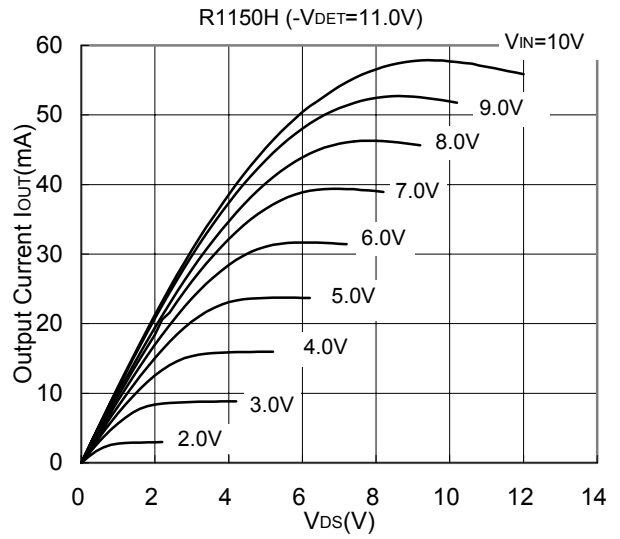
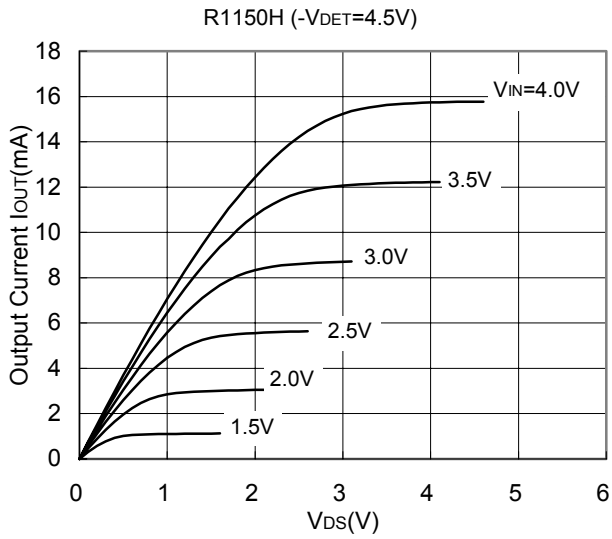

13) Nch Driver Output Current vs. Input Voltage

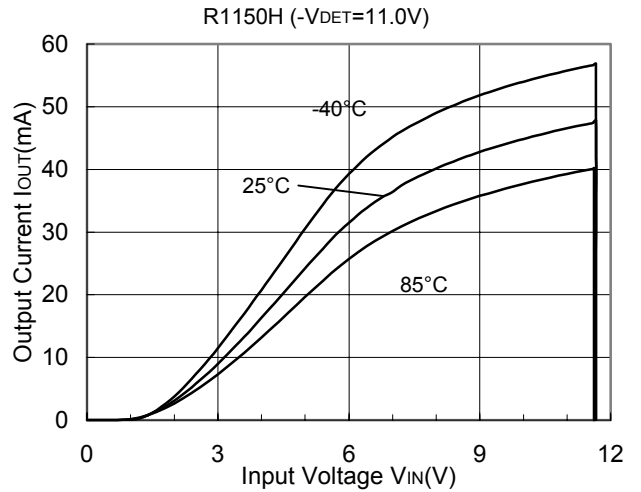
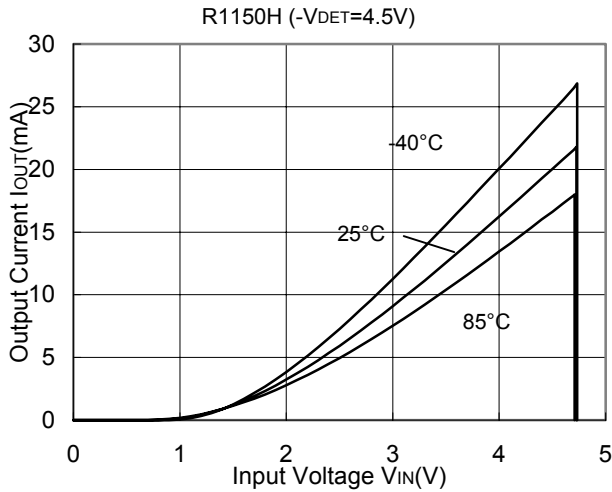

14) Detector Output Delay Time vs. Temperature

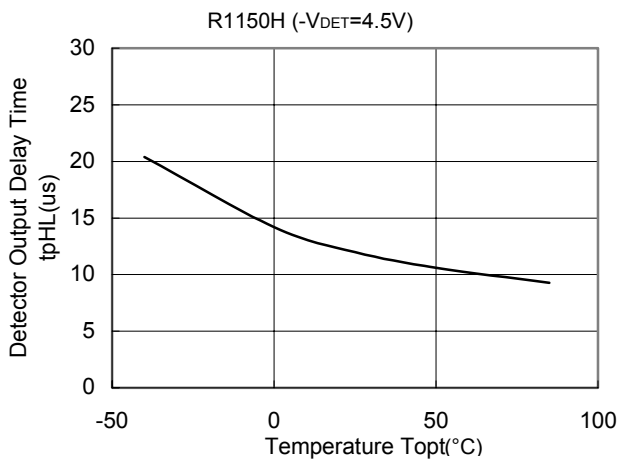

15) Thermal Shutdown Temperature vs. Output Voltage

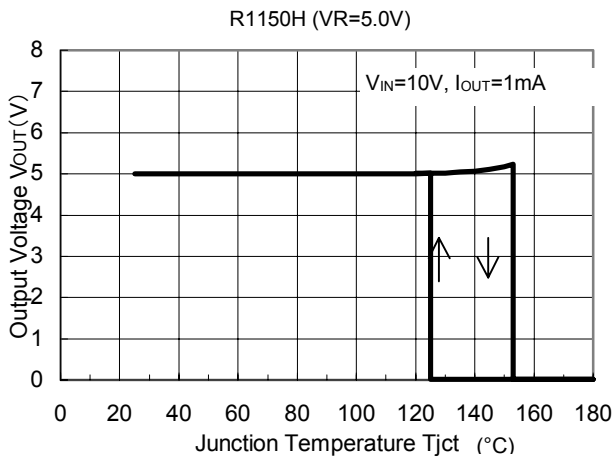

16) Output Delay Time vs. Temperature

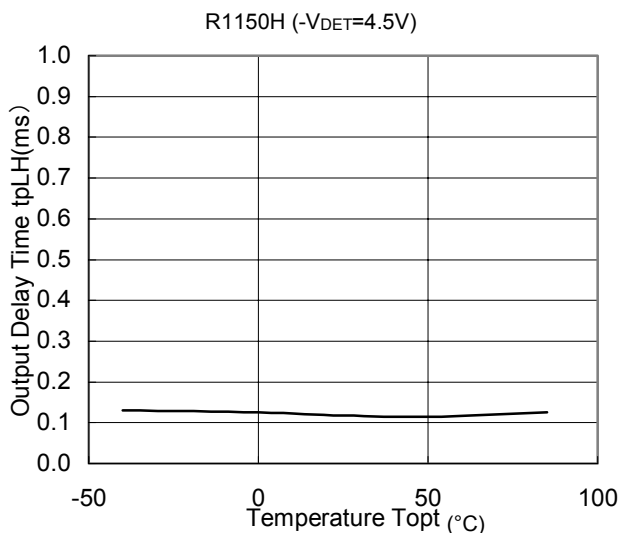

17) CD pin Threshold Voltage vs. Temperature

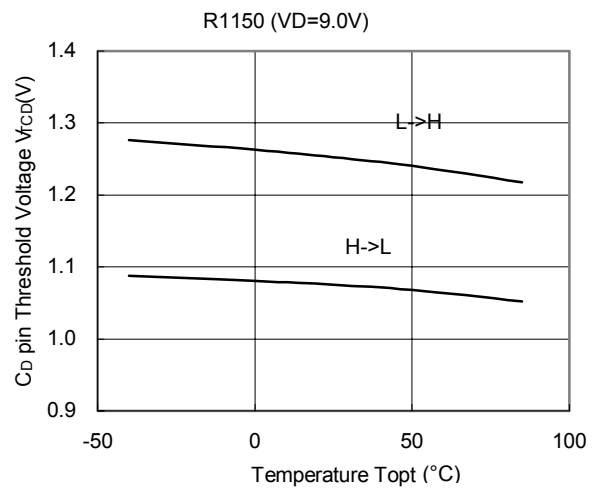
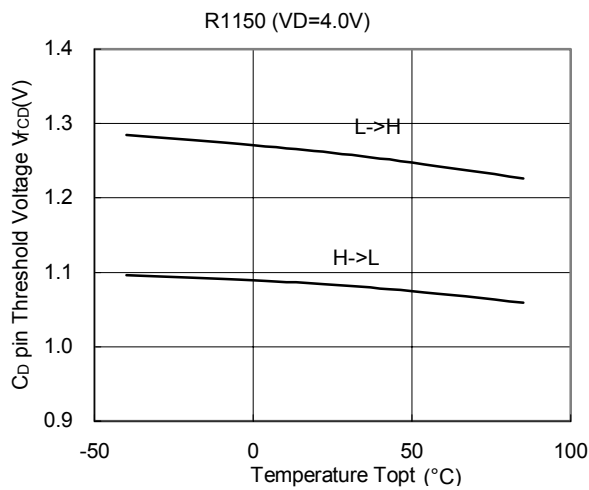

18) CD pin Sink Current vs. Input Voltage

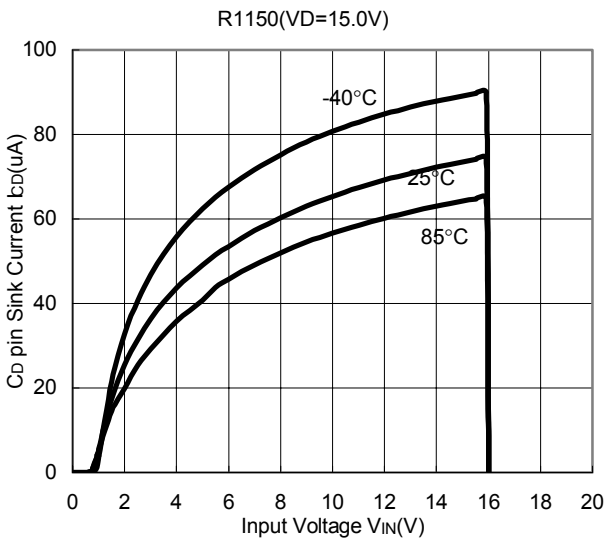
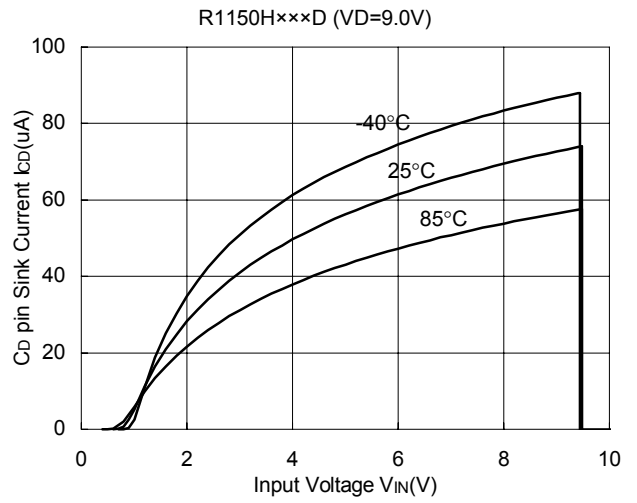
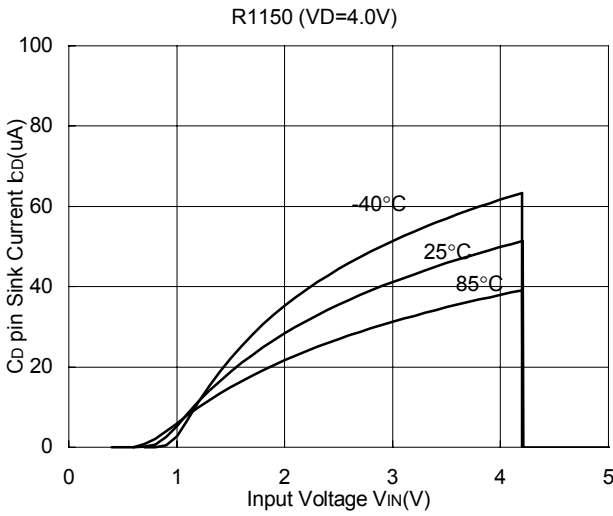

19) CD pin Sink Current vs. VDS

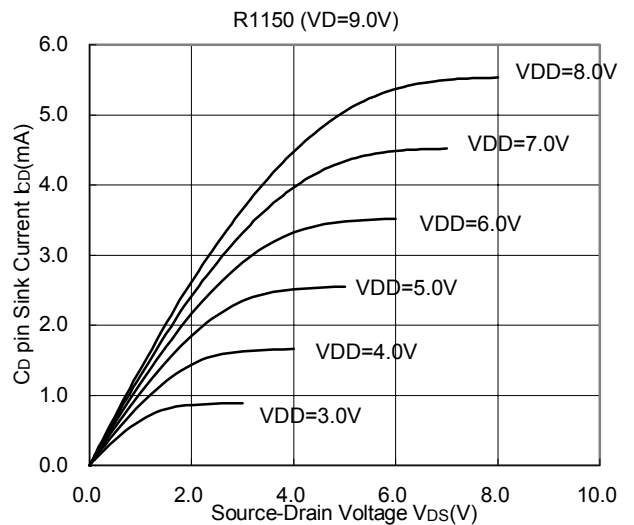
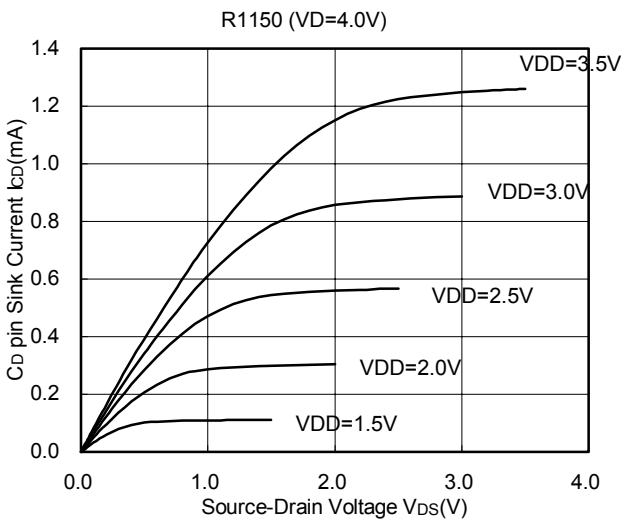

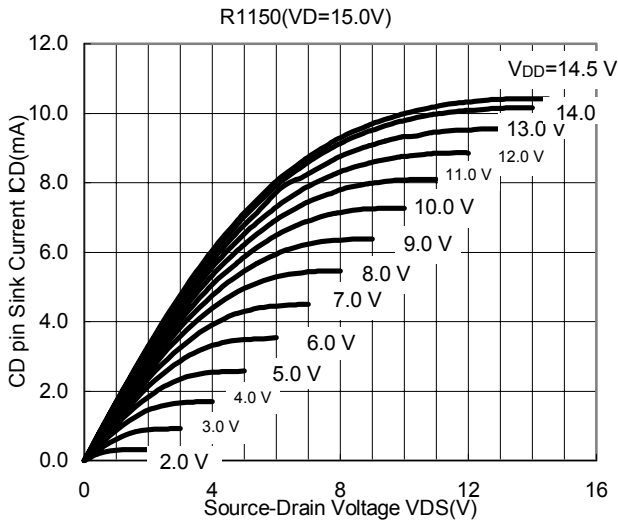

20) Output Delay Time vs. External Capacitance

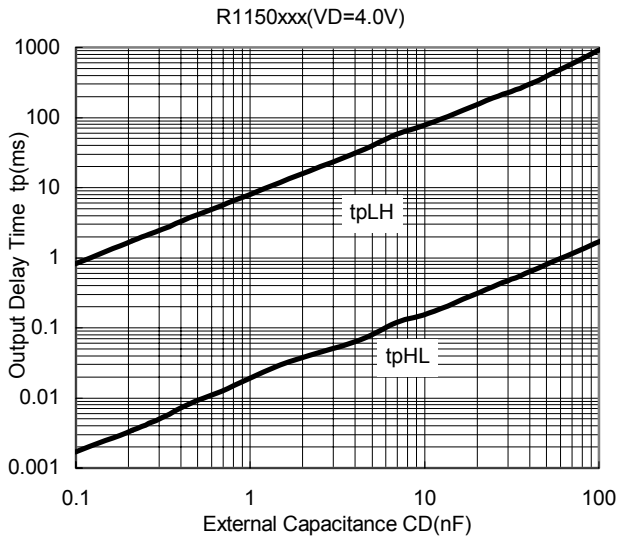

21) tpLH vs. Temperature

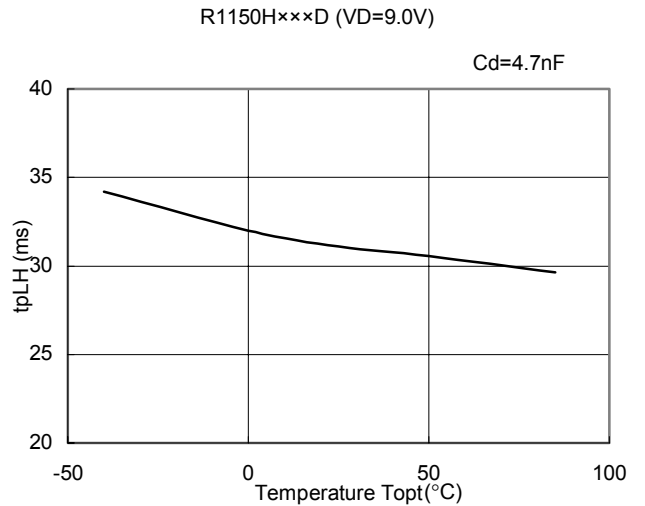
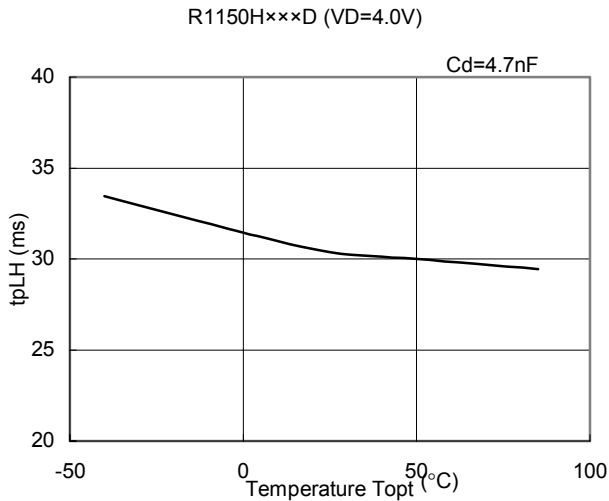

TECHNICAL NOTES

Phase Compensation

Phase Compensation of the R1150H Series has been made internally for stable operation even though the load current would vary. Therefore, without the capacitors, C_{IN} and C_{OUT} , Output Voltage is regulated, but for more stable operation, use capacitors as C_{IN} and C_{OUT} . Recommended value is in the range from 0.1 μ F to 1.0 μ F. Wiring should be made as short as possible.

PCB layout

Current flows into wiring for VDD or GND, thus, if the impedance of the wiring is rather high, it may cause of making noise or unstable operation, thus width and pattern should be enough wide to avoid such problems. Connect the capacitor, C_{IN} between VDD pin and GND pin as close as possible.

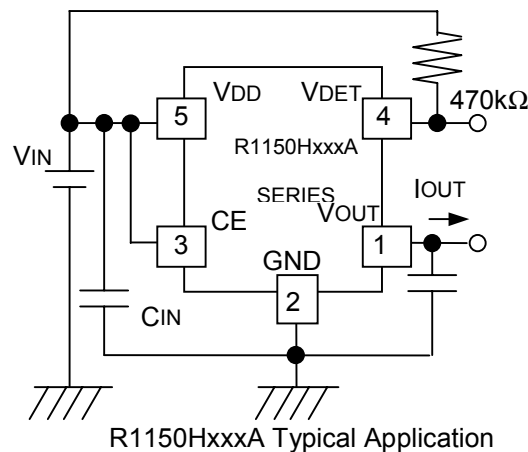

Thermal Shutdown

Thermal shutdown function is included in the R1150HxxxA/B/C/D Series, when the junction temperature is equal or more than +150°C (TYP.), the operation of regulator would stop. After that, when the junction temperature is equal or less than +120°C (TYP.), the operation of regulator would restart. Unless the cause of rising temperature would remove, the regulator repeats on and off, and output waveform would be like consecutive pulses.

Chip Enable Circuit

Do not make voltage level of chip enable pin keep floating level, or in between V_{IH} and V_{IL} . Unless otherwise, Output voltage would be unstable or indefinite, or unexpected current would flow internally.

Output Delay Time for Release VDET

In the R1150Hxx1C/D can set an output delay time for release voltage detector with connecting a capacitor to C_D pin. When an input voltage (in the case of R1150Hxx1C) or an output voltage (in the case of R1150Hxx1D) surpasses the release voltage of its voltage detector (+VDET), the capacitor which is connected to C_D pin is started to be charged, as a result, C_D pin voltage rises. When the C_D pin voltage surpasses C_D pin threshold voltage, the output voltage of the voltage detector outputs "H".

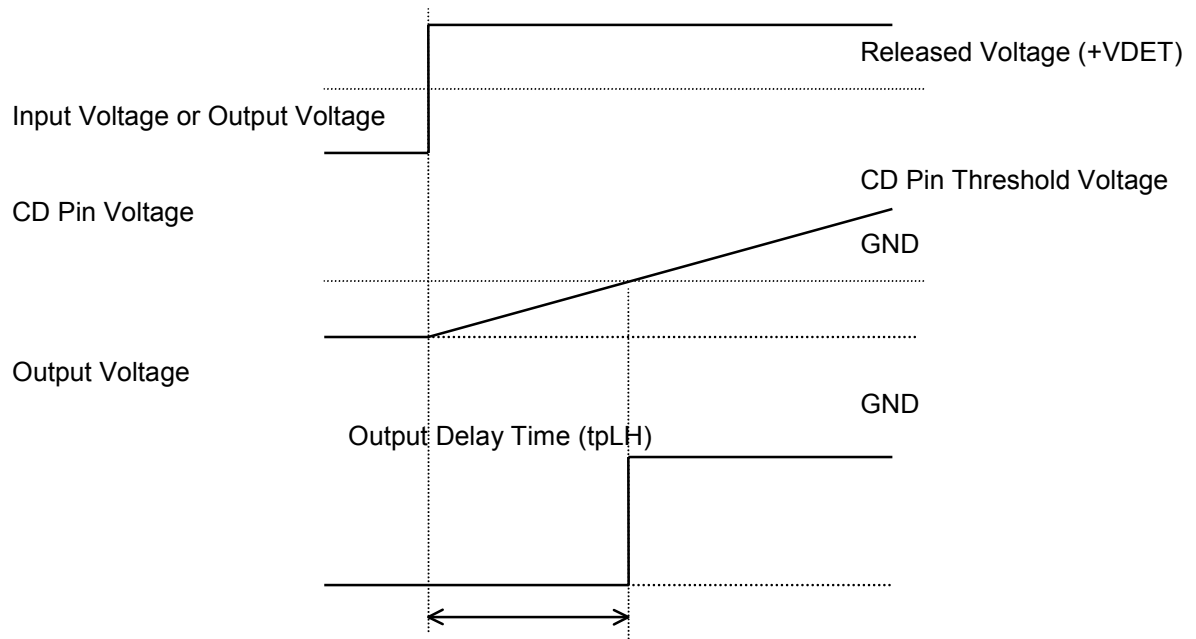

Output delay time for release voltage detector can be calculated with the next formula:

$$t_{pLH} = 1.25/200 \times 10^9 \times C \text{ (sec)}$$