

## GENERAL DESCRIPTION

The SM-T2 / SM-R2 is a pair of CMOS chip, it was designed for remote controlled car applications.

The SM-T2 / SM-R2 has five control keys for controlling the motions ( i.e. forward, backward rightward, leftward and the turbo function ) of the remote controller car.

## FEATURES

- \* Power supply : 2.4V - 5.0V
- \* Low stand-by current
- \* Five functions control
- \* Auto-power-off function for SM-T2
- \* Few external components are needed

## APPLICATION

- \* Remote control car etc.

## PIN ASSIGNMENTS (TOP VIEW)

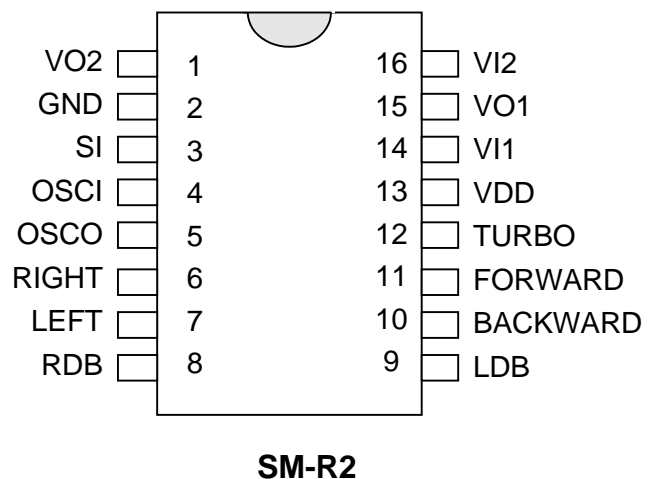
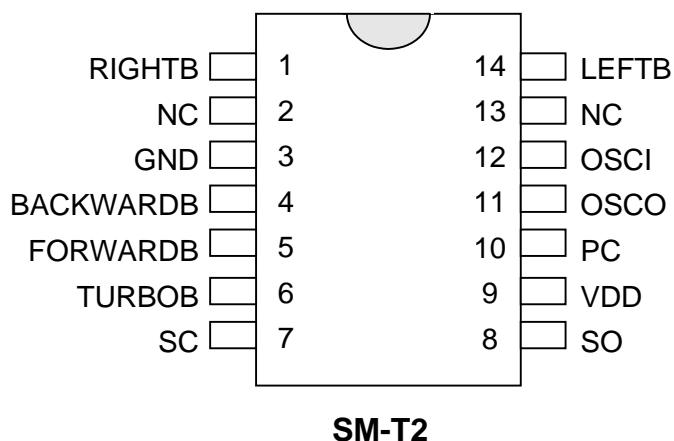

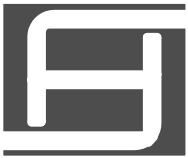

**BLOCK DIAGRAM**

**SM-T2**

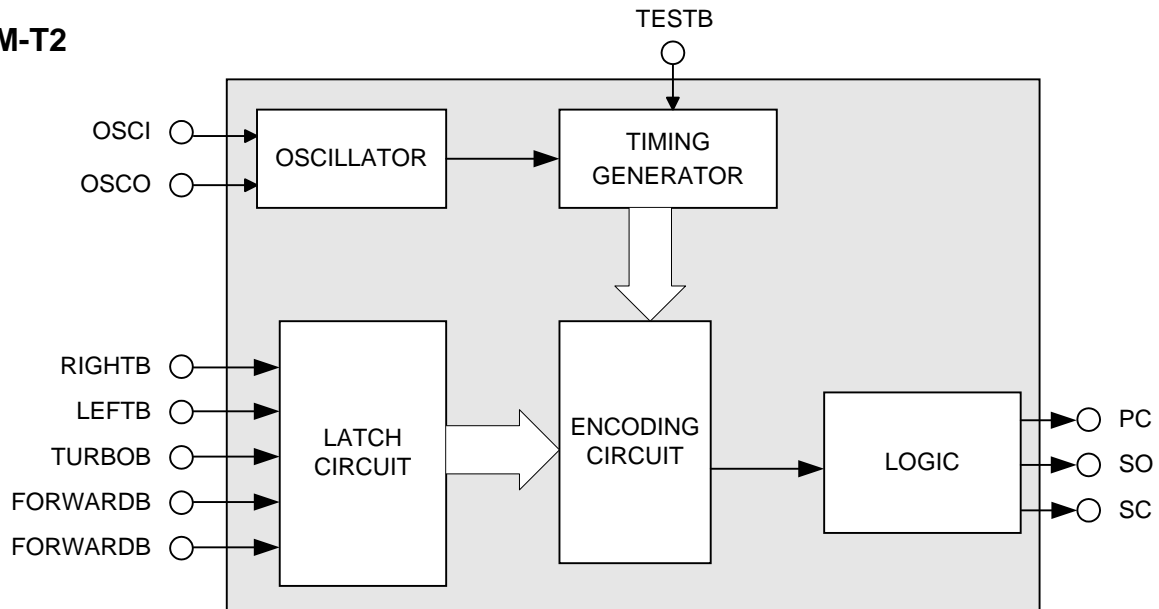

**SM-R2**

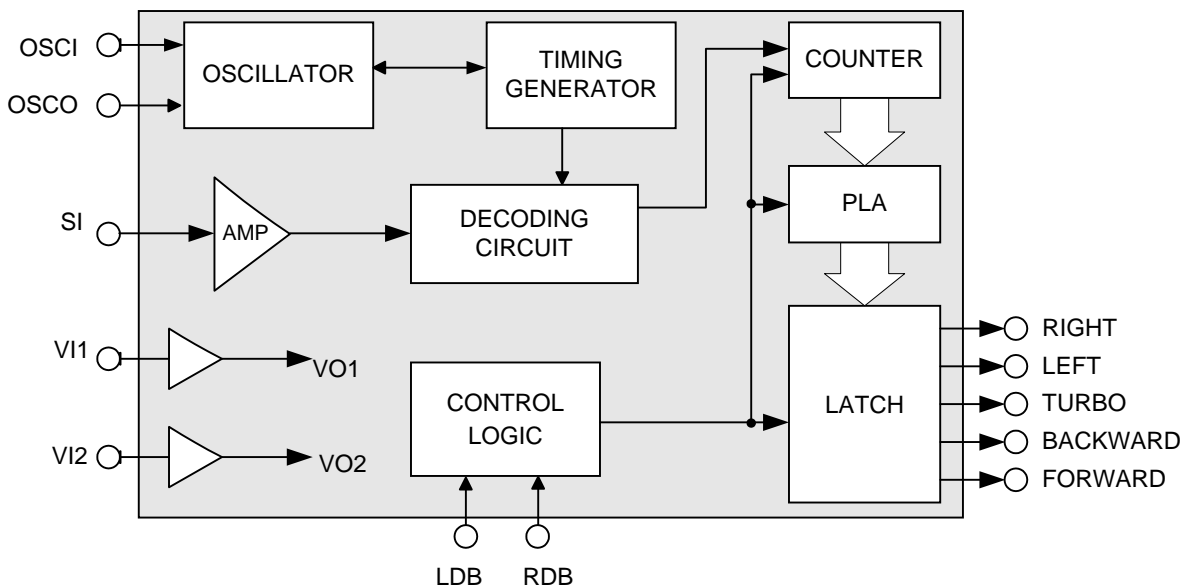



## PIN DESCRIPTION

### SM-T2

Pin No.	Pin Name	Description
1	RIGHTB	The rightward function will be selected, if this pin is connected to GND
2, 13	NC	
3	GND	Negative power supply
4	BACKWARDB	The backward function will be selected, if this pin is connected to GND
5	FORWARDB	The forward function will be selected, if this pin is connected to GND
6	TURBOB	The turbo function will be selected, if this pin is connected to GND
7	SC	Output pin of the encoding signal with carrier frequency
8	SO	
9	VDD	Positive power supply
10	PC	Power control output pin
11	OSCO	Oscillator output pin
12	OSCI	Oscillator input pin
14	LEFTB	The leftward function will be selected, if this pin is connected to GND

### SM-R2

Pin No.	Pin Name	Description
1	VO2	Inverter 2 output pin for power amplify
2	GND	Negative power supply
3	SI	Input pin of the encoding signal
4	OSCI	Oscillator input pin
5	OSCO	Oscillator output pin
6	RIGHT	Rightward output pin
7	LEFT	Leftward output pin
8	RDB	
9	LDB	Leftward function disable, if this pin is connected to GND
10	BACKWARD	Backward output pin
11	FORWARD	Forward output pin
12	TURBO	TURBO output pin
13	VDD	Positive power supply
14	VI1	Inverter 1 input pin for power amplify
15	VO1	Inverter 1 output pin for power amplify
16	VI2	Inverter 2 input pin for power amplify

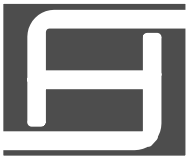

## FUNCTION DESCRIPTION

### 1. Code Format

Encode Rule (Bit Format)

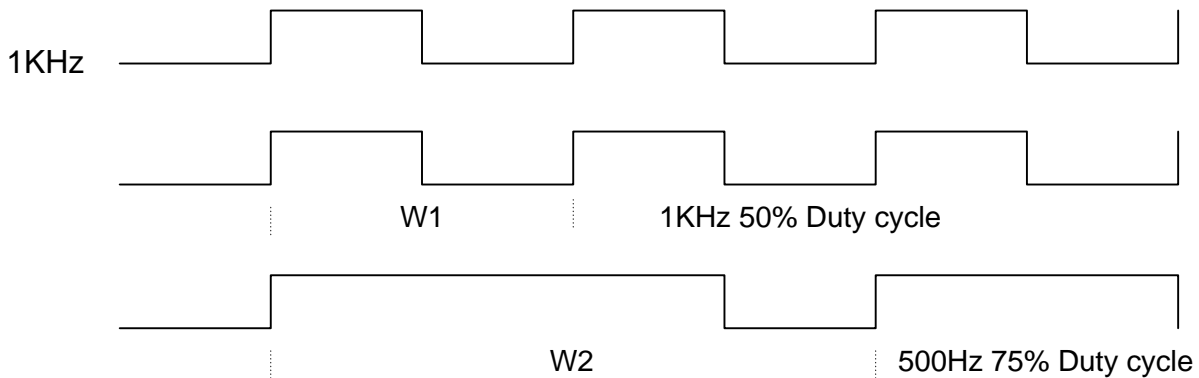

### 2. Data Format

W2 W2 W2 W2 (n) x W1 W2 W2 W2 W2 (n) x W1 W2 W2 W2 W2

No. of Function Code (n) W1	Function Key	Decode Result
4		End Code
10	Forward	Forward
16	Forward & Turbo	Forward
22	Turbo	Turbo
28	Turbo & Forward & Left	Forward & Left
34	Turbo & Forward & Right	Forward & Right
40	Backward	Backward
46	Backward & Right	Backward & Right
52	Backward & Left	Backward & Left
58	Left	Left
64	Right	Right

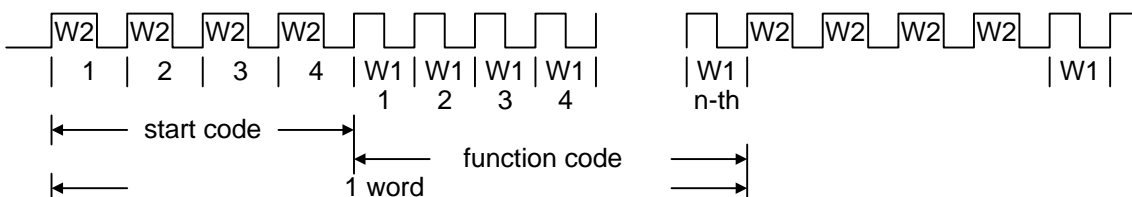



### 3. Encode/Decode Timing

(A)

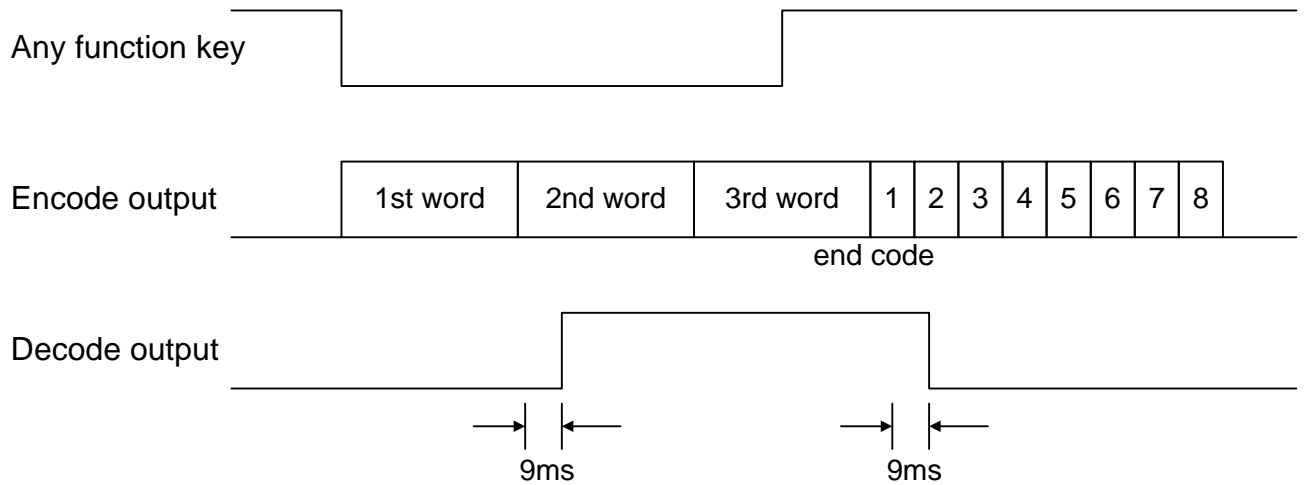

(B)

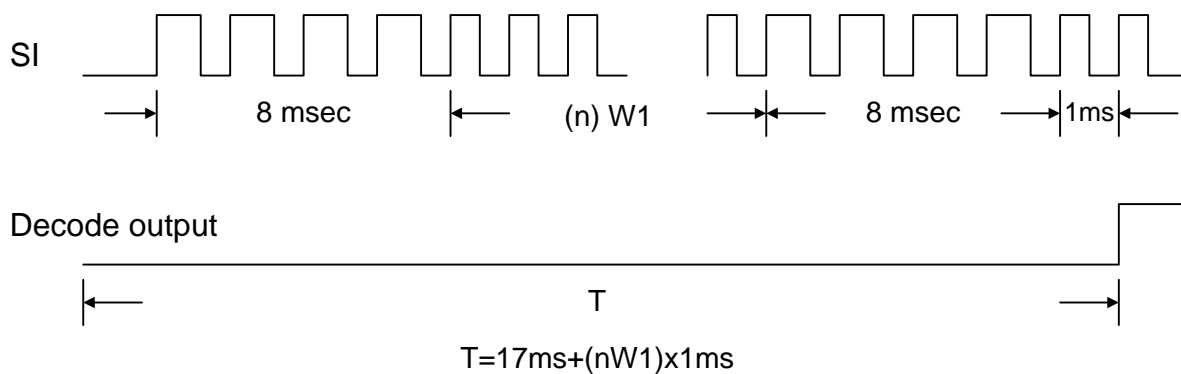



## ABSOLUTE MAXIMUM RATINGS

Parameter	Symbol	Ratings	Unit
DC Supply Voltage	VDD	5	V
Input/Output Voltage	VIN	GND-0.3 to VSS +0.3	V
Operating temperature	Topt	-10~60	°C
Storage Temperature	Tstg	-25~125	°C

## COMMENTS

Never allow a stress to exceed the values listed under "Absolute Maximum Ratings", otherwise the device would suffer from a permanent damage. Nor is a stress since an extended exposure to the absolute maximum rating condition may also affect the reliability of the device, if not causing a damage thereof.

## DC ELECTRICAL CHARACTERISTICS

**TX2 (VDD=4.5V, Fosc=128KHz, TA=25°C, unless otherwise specified.)**

Parameter	Symbol	Min.	Typ.	Max.	Unit
Operating Voltage	VDD	3	4	5	V
Operating Current	I <sub>dd</sub>			2	mA
Stand-by Current	I <sub>stb</sub>			10	μA
DC O/P Driving Current	I <sub>drive</sub>	5			mA
AC O/P Driving Current	I <sub>drive</sub>	5			mA
AC O/P Frequency	F <sub>audio</sub>	500		1K	Hz

**RX2 (VDD=4.0V, Fosc=128KHz, TA=25°C, unless otherwise specified.)**

Parameter	Symbol	Min.	Typ.	Max.	Unit
Operating Voltage	VDD	3	4	5	V
Operating Current	I <sub>dd</sub>			2	mA
O/P Driving Current	I <sub>drive</sub>	1			mA
O/P Sinking Current	I <sub>sink</sub>	1			mA
Effect Decoding Frequency Variation	F <sub>tolerance</sub>	-20		20	%



**APPLICATION CIRCUIT**

**TX2**

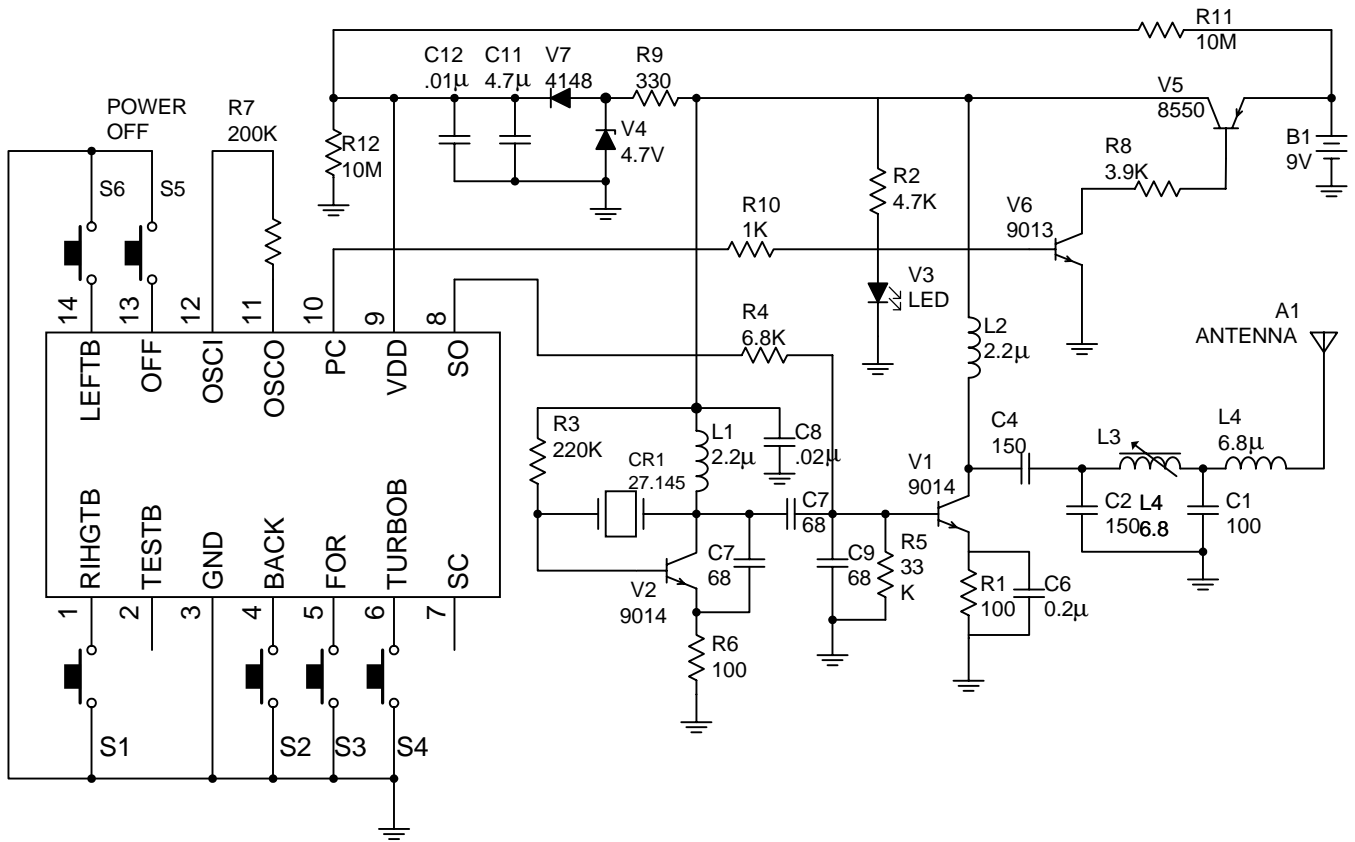

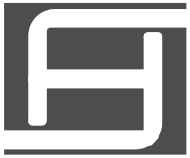

**APPLICATION CIRCUIT**

**RX**

