



2N60

Power MOSFET

2 Amps, 600/650 Volts N-CHANNEL MOSFET

DESCRIPTION

The UTC **2N60** is a high voltage MOSFET and is designed to have better characteristics, such as fast switching time, low gate charge, low on-state resistance and have a high rugged avalanche characteristics. This power MOSFET is usually used at high speed switching applications in power supplies, PWM motor controls, high efficient DC to DC converters and bridge circuits.

FEATURES

- * $R_{DS(ON)} = 5\Omega @ V_{GS} = 10V$
- * Ultra Low gate charge (typical 9.0nC)
- * Low reverse transfer capacitance ($C_{RSS} =$ typical 5.0 pF)
- * Fast switching capability
- * Avalanche energy specified
- * Improved dv/dt capability, high ruggedness

SYMBOL

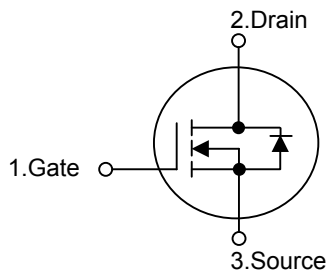

ORDERING INFORMATION

Normal	Ordering Number		Package	Pin Assignment			Packing
	Lead Free Plating	Halogen Free		1	2	3	
2N60-x-TA3-T	2N60L-x-TA3-T	2N60G-x-TA3-T	TO-220	G	D	S	Tube
2N60-x-TF3-T	2N60L-x-TF3-T	2N60G-x-TF3-T	TO-220F	G	D	S	Tube
2N60-x-TM3-T	2N60L-x-TM3-T	2N60G-x-TM3-T	TO-251	G	D	S	Tube
2N60-x-TN3-R	2N60L-x-TN3-R	2N60G-x-TN3-R	TO-252	G	D	S	Tape Reel
2N60-x-TN3-T	2N60L-x-TN3-T	2N60G-x-TN3-T	TO-252	G	D	S	Tube

Note: Pin Assignment: G: Gate D: Drain S: Source

<p>2N60L-x-TA3-T</p> <p>(1)Packing Type (2)Package Type (3)Drain-Source Voltage (4)Lead Plating</p>	<p>(1) T: Tube, R: Tape Reel (2) TA3: TO-220, TF3: TO-220F, TM3: TO-251, TN3: TO-252 (3) A: 600V, B: 650V (4) G: Halogen Free, L: Lead Free, Blank: Pb/Sn</p>
---	---

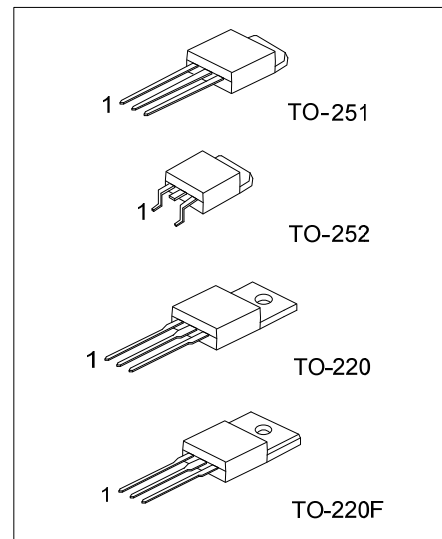

Lead-free: 2N60L
Halogen-free: 2N60G

■ ABSOLUTE MAXIMUM RATINGS ($T_C = 25^\circ\text{C}$, unless otherwise specified)

PARAMETER		SYMBOL	RATINGS	UNIT
Drain-Source Voltage	2N60-A	V_{DSS}	600	V
	2N60-B		650	V
Gate-Source Voltage		V_{GSS}	± 30	V
Avalanche Current (Note 1)		I_{AR}	2.0	A
Drain Current Continuous		I_D	2.0	A
Drain Current Pulsed (Note 1)		I_{DP}	8.0	A
Avalanche Energy	Single Pulsed (Note 2)	E_{AS}	140	mJ
	Repetitive (Note 1)	E_{AR}	4.5	mJ
Peak Diode Recovery dv/dt (Note 3)		dv/dt	4.5	V/ns
Total Power Dissipation	TO-220	P_D	54	W
	TO-220F		23	W
	TO-251		44	W
	TO-252		44	W
Junction Temperature		T_J	+150	$^\circ\text{C}$
Operating Temperature		T_{OPR}	-55 ~ +150	$^\circ\text{C}$
Storage Temperature		T_{STG}	-55 ~ +150	$^\circ\text{C}$

Note: Absolute maximum ratings are those values beyond which the device could be permanently damaged. Absolute maximum ratings are stress ratings only and functional device operation is not implied.

■ THERMAL DATA

PARAMETER	PACKAGE	SYMBOL	RATINGS	UNIT
Junction-to-Ambient	TO-220	θ_{JA}	62.5	$^\circ\text{C/W}$
	TO-220F		62.5	
	TO-251		50	
	TO-252		50	
Junction-to-Case	TO-220	θ_{JC}	2.32	$^\circ\text{C/W}$
	TO-220F		5.5	
	TO-251		2.87	
	TO-252		2.87	

■ ELECTRICAL CHARACTERISTICS ($T_J = 25^\circ\text{C}$, unless otherwise specified)

PARAMETER	SYMBOL	TEST CONDITIONS	MIN	TYP	MAX	UNIT
OFF CHARACTERISTICS						
Drain-Source Breakdown Voltage	2N60-A	BV_{DSS}	$V_{GS} = 0V, I_D = 250\mu\text{A}$	600		V
	2N60-B			650		V
Drain-Source Leakage Current		I_{DSS}	$V_{DS} = 600V, V_{GS} = 0V$		10	μA
Gate-Source Leakage Current	Forward	I_{GSS}	$V_{GS} = 30V, V_{DS} = 0V$		100	nA
	Reverse		$V_{GS} = -30V, V_{DS} = 0V$		-100	nA
Breakdown Voltage Temperature Coefficient		$\Delta BV_{DSS}/\Delta T_J$	$I_D = 250\mu\text{A}$, Referenced to 25°C	0.4		$V/^\circ\text{C}$
ON CHARACTERISTICS						
Gate Threshold Voltage		$V_{GS(TH)}$	$V_{DS} = V_{GS}, I_D = 250\mu\text{A}$	2.0	4.0	V
Static Drain-Source On-State Resistance		$R_{DS(ON)}$	$V_{GS} = 10V, I_D = 1A$	3.8	5	Ω
DYNAMIC CHARACTERISTICS						
Input Capacitance		C_{ISS}	$V_{DS} = 25V, V_{GS} = 0V, f = 1\text{MHz}$	270	350	pF
Output Capacitance		C_{OSS}		40	50	pF
Reverse Transfer Capacitance		C_{RSS}		5	7	pF

■ ELECTRICAL CHARACTERISTICS(Cont.)

PARAMETER	SYMBOL	TEST CONDITIONS	MIN	TYP	MAX	UNIT
SWITCHING CHARACTERISTICS						
Turn-On Delay Time	$t_{D(ON)}$	$V_{DD}=300V, I_D=2.4A, R_G=25\Omega$ (Note 4, 5)		10	30	ns
Turn-On Rise Time	t_R			25	60	ns
Turn-Off Delay Time	$t_{D(OFF)}$			20	50	ns
Turn-Off Fall Time	t_F			25	60	ns
Total Gate Charge	Q_G	$V_{DS}=480V, V_{GS}=10V, I_D=2.4A$ (Note 4, 5)		9.0	11	nC
Gate-Source Charge	Q_{GS}			1.6		nC
Gate-Drain Charge	Q_{GD}			4.3		nC
DRAIN-SOURCE DIODE CHARACTERISTICS						
Drain-Source Diode Forward Voltage	V_{SD}	$V_{GS} = 0 V, I_{SD} = 2.0 A$			1.4	V
Continuous Drain-Source Current	I_{SD}				2.0	A
Pulsed Drain-Source Current	I_{SM}				8.0	A
Reverse Recovery Time	t_{RR}	$V_{GS} = 0 V, I_{SD} = 2.4A,$		180		ns
Reverse Recovery Charge	Q_{RR}	$di/dt = 100 A/\mu s$ (Note4)		0.72		μC

- Note:
1. Repetitive Rating : Pulse width limited by T_J
 2. $L=64mH, I_{AS}=2.0A, V_{DD}=50V, R_G=25 \Omega, \text{Starting } T_J = 25^\circ C$
 3. $I_{SD} \leq 2.4A, di/dt \leq 200A/\mu s, V_{DD} \leq BV_{DSS}, \text{Starting } T_J = 25^\circ C$
 4. Pulse Test: Pulse width $\leq 300\mu s, \text{Duty cycle } \leq 2\%$
 5. Essentially independent of operating temperature

■ TEST CIRCUITS AND WAVEFORMS

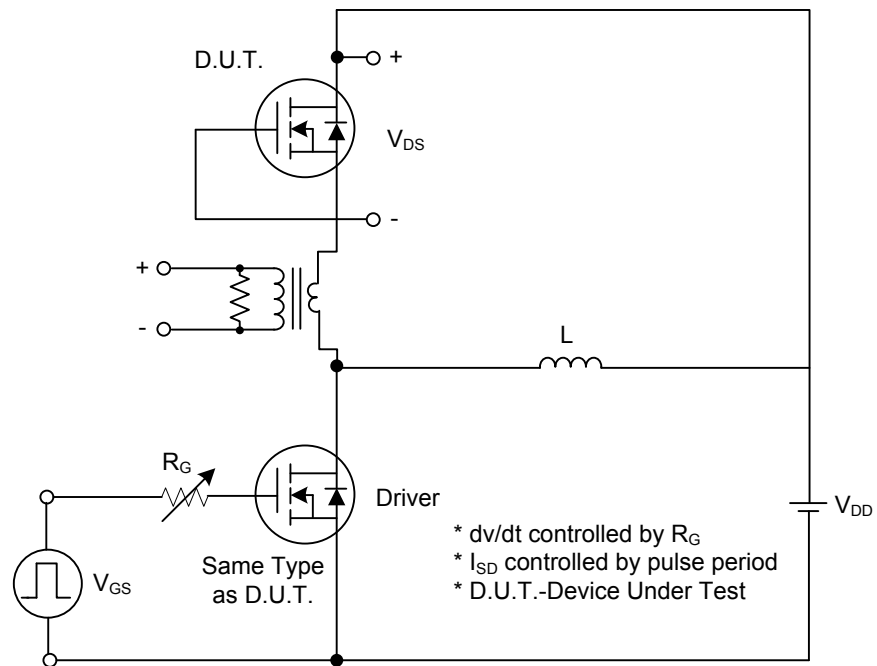

Fig. 1A Peak Diode Recovery dv/dt Test Circuit

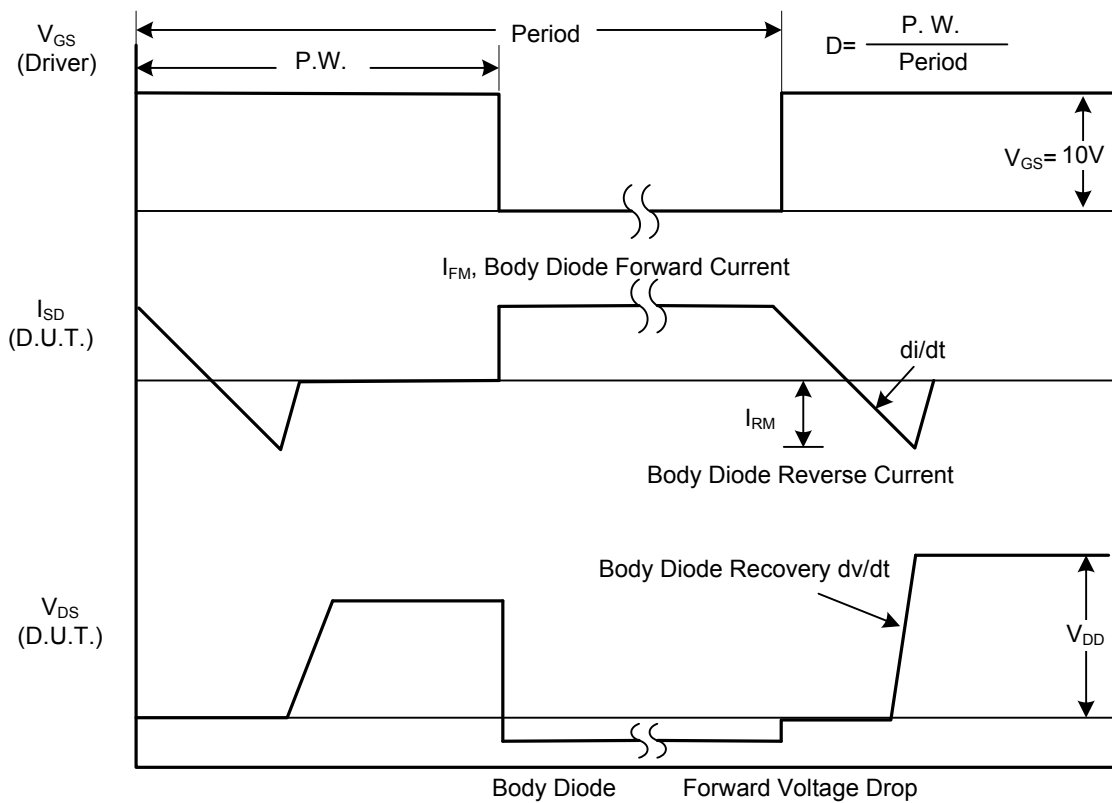

Fig. 1B Peak Diode Recovery dv/dt Waveforms

■ TEST CIRCUITS AND WAVEFORMS (Cont.)

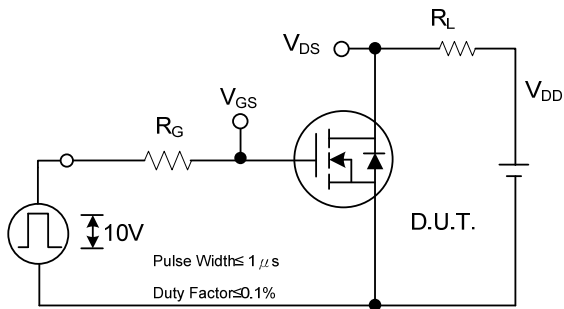

Fig. 2A Switching Test Circuit

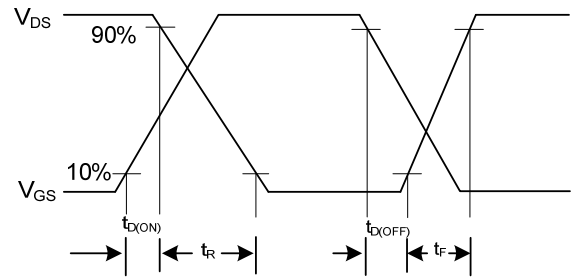

Fig. 2B Switching Waveforms

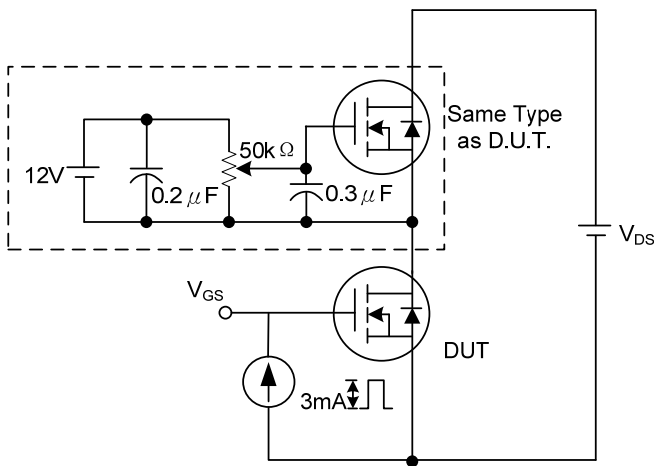

Fig. 3A Gate Charge Test Circuit

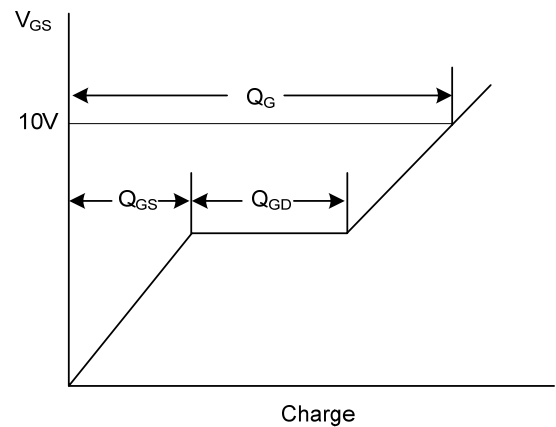

Fig. 3B Gate Charge Waveform

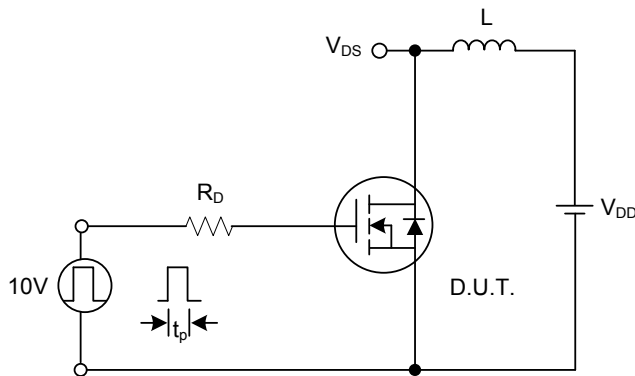

Fig. 4A Unclamped Inductive Switching Test Circuit

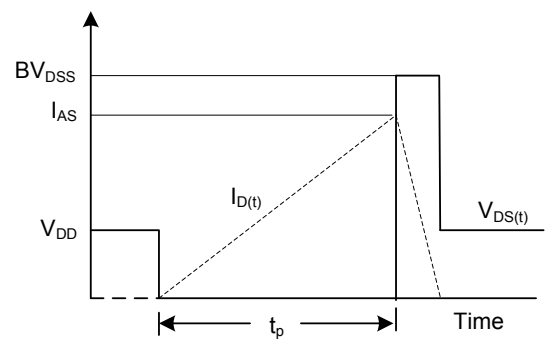
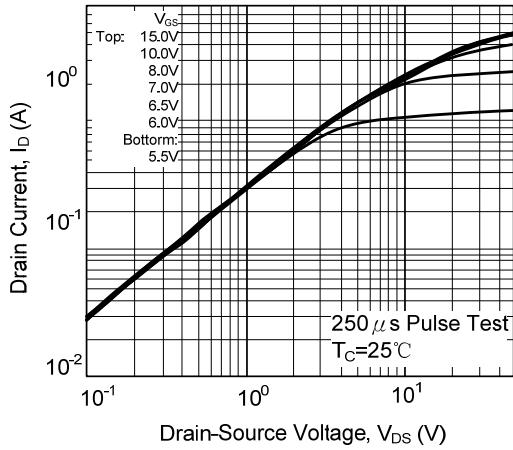

Fig. 4B Unclamped Inductive Switching Waveforms

■ TYPICAL CHARACTERISTICS

On-Region Characteristics



Transfer Characteristics

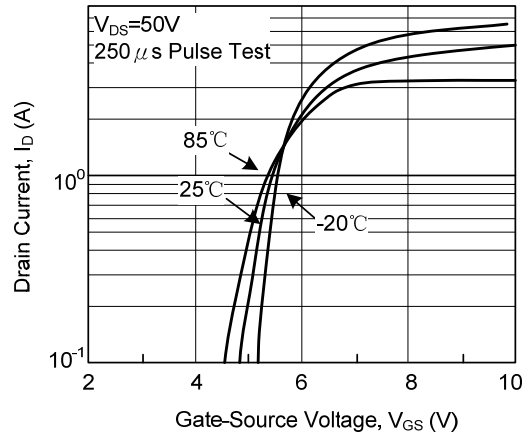

On-Resistance Variation vs. Drain Current and Gate Voltage

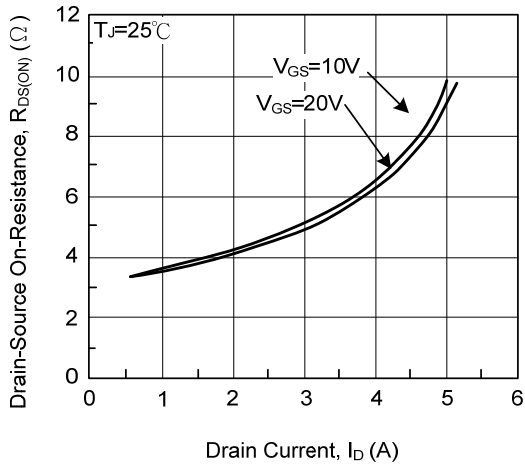

Body Diode Forward Voltage Variation vs. Source Current and Temperature

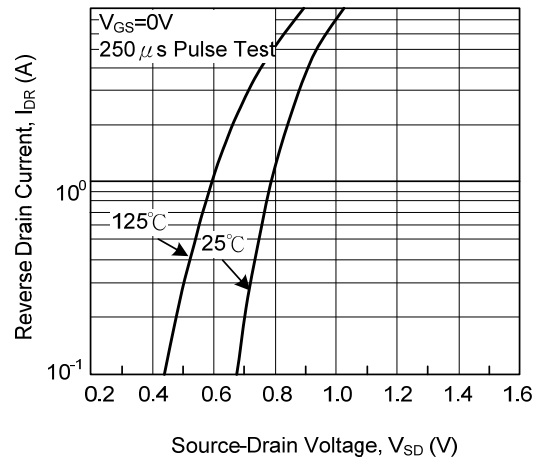

Capacitance vs. Drain-Source Voltage

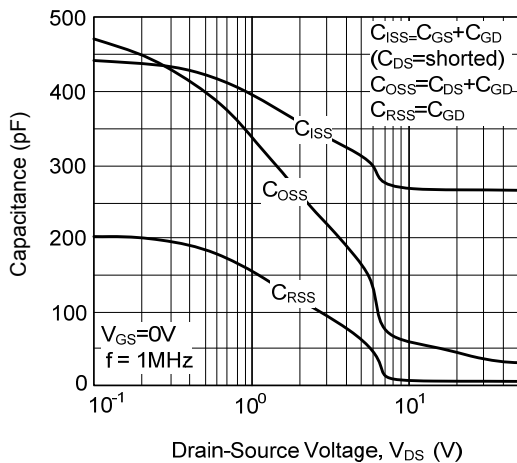

Gate Charge vs. Gate Charge Voltage

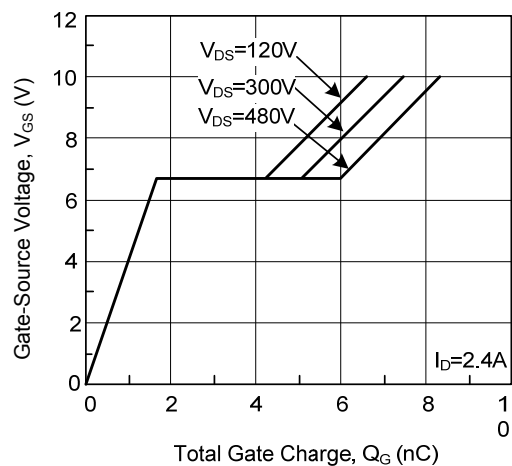

■ TYPICAL CHARACTERISTICS(Cont.)

Breakdown Voltage vs. Temperature

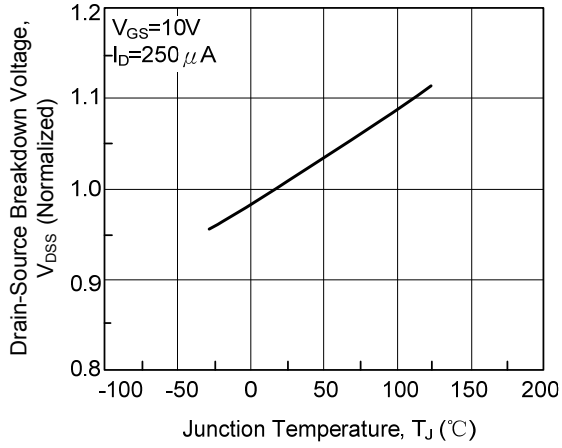

On-Resistance vs. Temperature

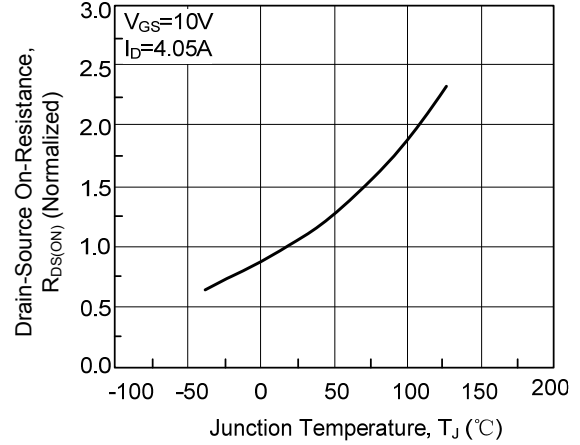

Max. Safe Operating Area

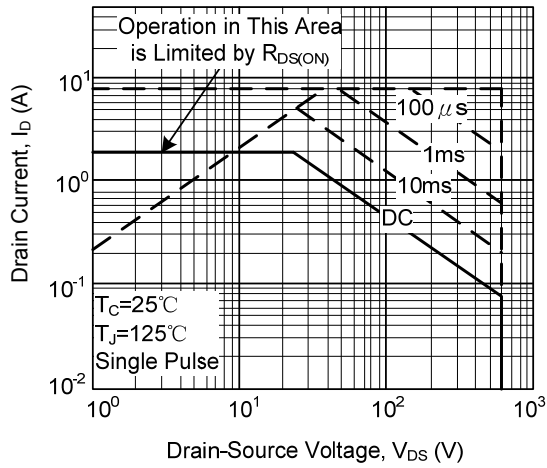

Max. Drain Current vs. Case Temperature

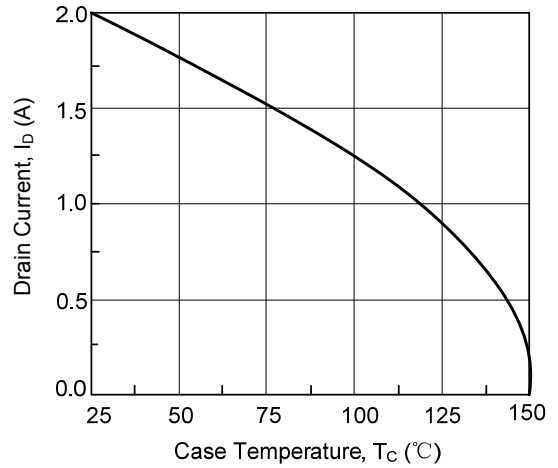

Thermal Response

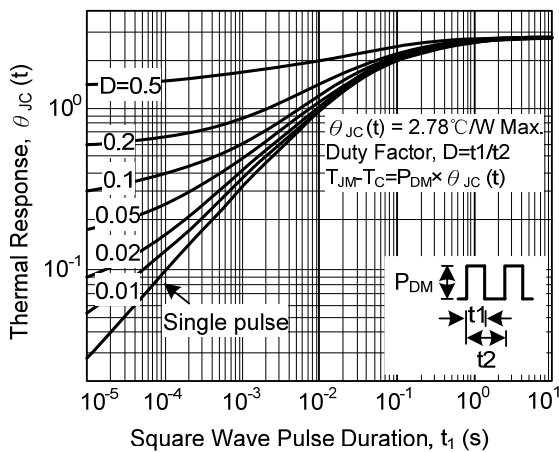

UTC assumes no responsibility for equipment failures that result from using products at values that exceed, even momentarily, rated values (such as maximum ratings, operating condition ranges, or other parameters) listed in products specifications of any and all UTC products described or contained herein. UTC products are not designed for use in life support appliances, devices or systems where malfunction of these products can be reasonably expected to result in personal injury. Reproduction in whole or in part is prohibited without the prior written consent of the copyright owner. The information presented in this document does not form part of any quotation or contract, is believed to be accurate and reliable and may be changed without notice.