

T-25-23

V <sub>RSM</sub> V <sub>RRM</sub>	I <sub>FRMS</sub> (maximum values for continuous operation)			
	130 A	130 A	300 A	300 A
V	I <sub>FAV</sub> (sin. 180; T <sub>case</sub> = ... °C; 50 Hz)			
	60 A (94 °C)	60 A (94 °C)	160 A (86 °C)	160 A (86 °C)
400	-	-	SKFH 110 /04..	-
800	SKFH 40/08	SKFH 60/08..	SKFH 110 /08..	SKKD 160 M 08
1000	SKFH 40/10	SKFH 60/10..	SKFH 110 /10..	SKKD 160 M 10
1200	SKFH 40/12	SKFH 60/12..	SKFH 110 /12..	SKKD 160 M 12
1400	-	-	-	SKKD 160 M 14

**Fast Thyristor/ Diode Modules**

**SEMIPACK® 1**



**SEMIPACK® 3**

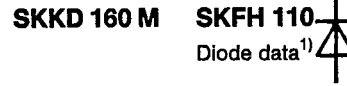

Symbol	Conditions	SKFH 40 <sup>1)</sup> SKFH 60 <sup>1)</sup>	SKKD 160 M SKFH 110 <sup>1)</sup>
I <sub>FAV</sub>	sin. 180; T <sub>case</sub> = 85 °C	73 A	163 A
I <sub>FSM</sub>	T <sub>vj</sub> = 25 °C	1800 A	7000 A
	T <sub>vj max</sub>	1500 A	6000 A
i <sup>2</sup> t	T <sub>vj</sub> = 25 °C	16000 A <sup>2</sup> s	245000 A <sup>2</sup> s
	T <sub>vj max</sub>	11000 A <sup>2</sup> s	180000 A <sup>2</sup> s
t <sub>rr</sub>	T <sub>vj</sub> = 25 °C; I <sub>F</sub> = 1 A; -di <sub>F</sub> /dt = 15 A/μs; V <sub>R</sub> = 30 V	2 μs	2 μs
Q <sub>rr</sub>	T <sub>vj max</sub> ; I <sub>F</sub> = 100 A; -di <sub>F</sub> /dt = 30 A/μs; V <sub>R</sub> = 30 V	65 μC	65 μC
I <sub>RM</sub>		35 A	45 A
I <sub>R</sub>	T <sub>vj</sub> = 25 °C; V <sub>R</sub> = V <sub>RRM</sub> T <sub>vj max</sub> ; V <sub>R</sub> = V <sub>RRM</sub>	1 mA 10 mA	2 mA 50 mA
V <sub>F</sub>	T <sub>vj</sub> = 25 °C; I <sub>F</sub> = ... A	1,6 V (200 A)	1,5 V (400 A)
V <sub>(TO)</sub>	T <sub>vj max</sub>	1,0 V	1,25 V
r <sub>T</sub>		2 mΩ	0,5 mΩ
R <sub>thjc</sub>	per diode/per module	0,4/0,2 °C/W <sup>2)</sup>	0,19/0,095 °C/W <sup>2)</sup>
R <sub>thch</sub>		0,2/0,1 °C/W	0,06/0,03 °C/W
T <sub>vj</sub>		-40 ... +125 °C	-40 ... +130 °C
T <sub>stg</sub>		-40 ... +125 °C	-40 ... +130 °C
V <sub>isol</sub>	a. c. 50 Hz; r. m. s.; 1 s/1 min.	3000 V ~ /2500 V ~ <sup>2)</sup>	
M <sub>1</sub>	Case to heatsink } Busbars to terminals } SI units/ US units	5 Nm/44 lb. in. ± 15 %	5 Nm/44 lb. in. ± 15 %
M <sub>2</sub>		3 Nm/26 lb. in. ± 15 %	9 Nm/80 lb. in. ± 15 %
w	approx.	120 g	800 g
Case	→ page B 2-12	A 8	
Case	→ page B 2-32	SKKD SKFH	A 16 A 14

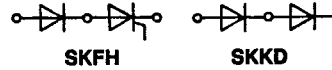
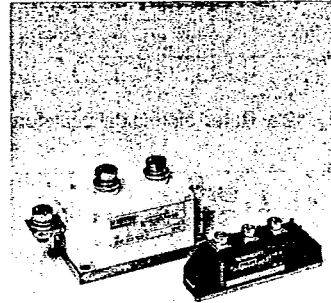

**Features**

- Heat transfer through ceramic isolated metal baseplate
- Hard soldered joints for high reliability
- SKKD 160 M: Precious metal pressure contacts
- UL recognized, file no. E 63 532

**Typical Applications**

- Self-commutated inverters
- DC choppers
- AC motor speed control
- Inductive heating
- Uninterruptible power supplies
- Electronic welders
- General power switching applications

<sup>1)</sup> For the data of the thyristors see pages B 2-37 and B 2-43  
<sup>2)</sup> Internal insulation: beryllium oxide · Observe the warning on page B 2-1.

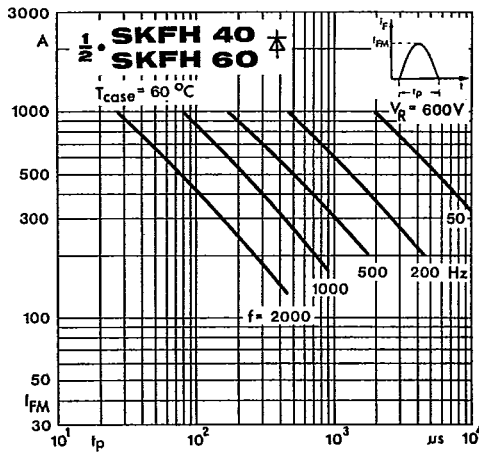

Fig. 12 a Rated sinusoidal peak forward current

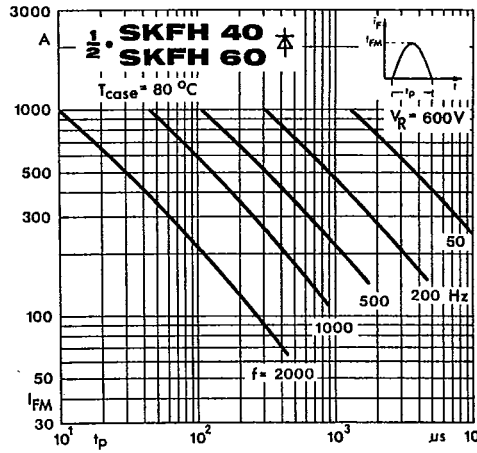

Fig. 12 b Rated sinusoidal peak forward current

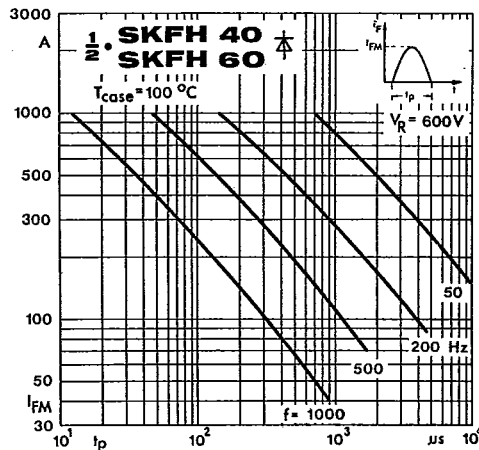

Fig. 12 c Rated sinusoidal peak forward current

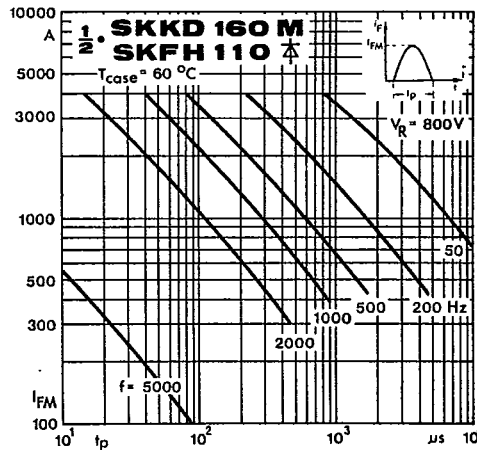

Fig. 12 d Rated sinusoidal peak forward current

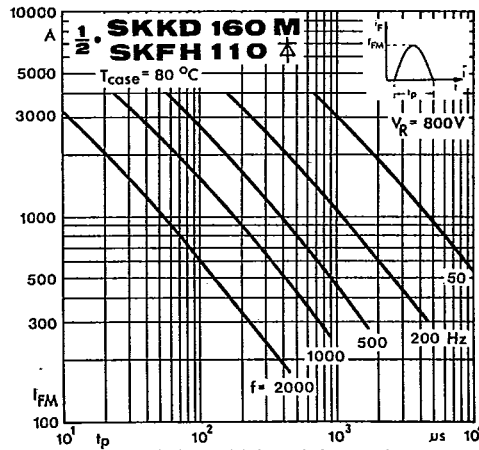

Fig. 12 e Rated sinusoidal peak forward current

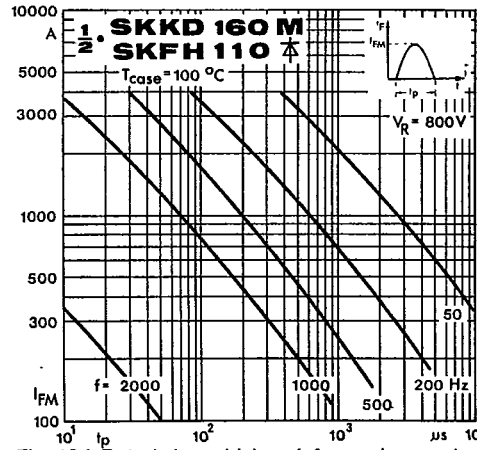

Fig. 12 f Rated sinusoidal peak forward current

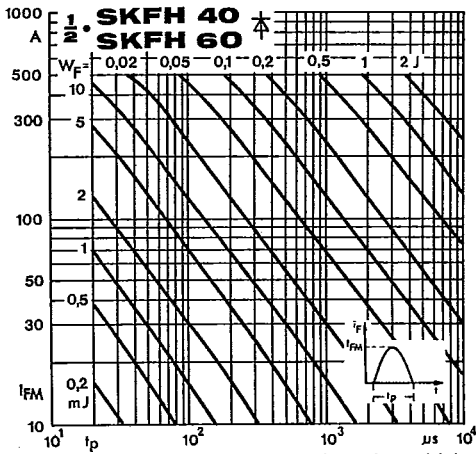

Fig. 13 a Forward energy dissipation, sinusoidal

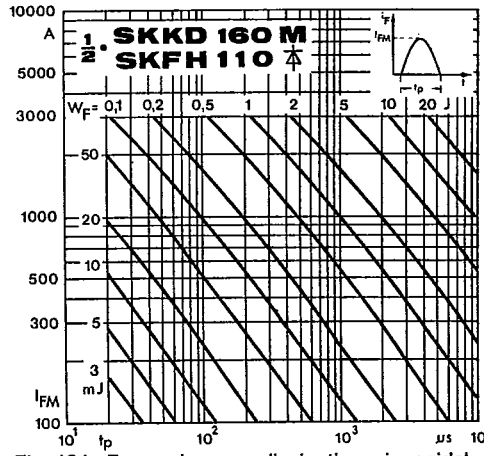

Fig. 13 b Forward energy dissipation, sinusoidal

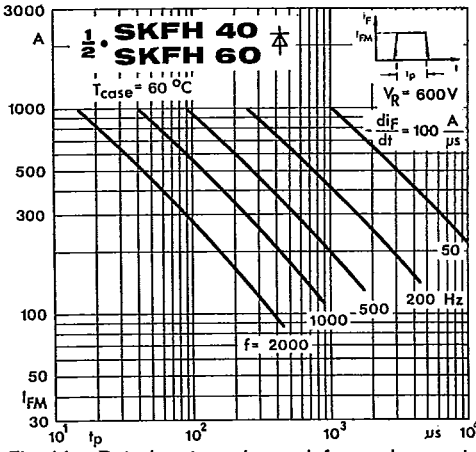

Fig. 14 a Rated rectangular peak forward current

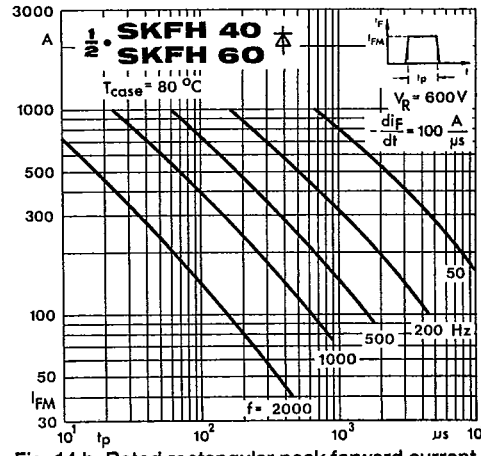

Fig. 14 b Rated rectangular peak forward current

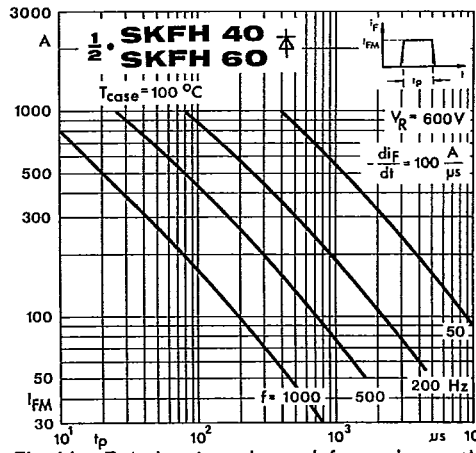

Fig. 14 c Rated rectangular peak forward current

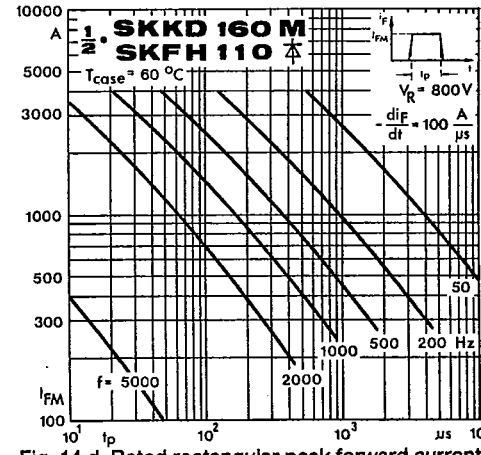

Fig. 14 d Rated rectangular peak forward current

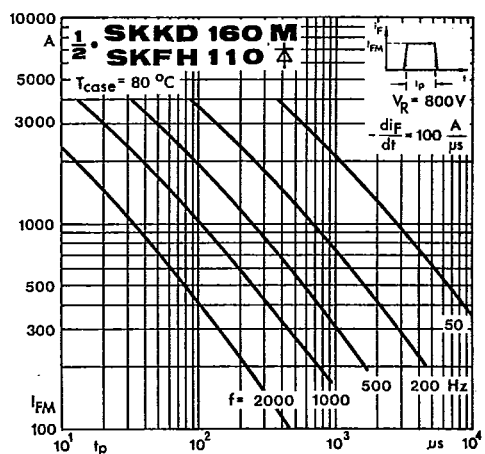

Fig. 14 e Rated rectangular peak forward current

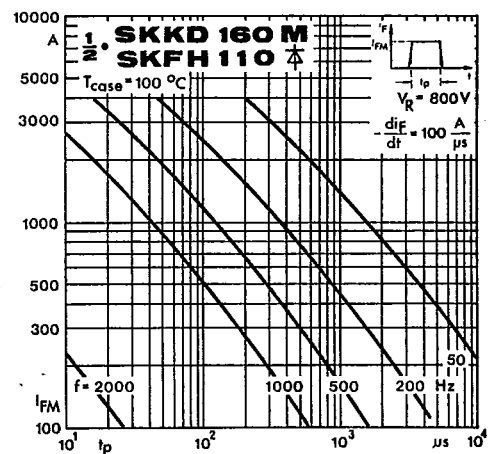

Fig. 14 f Rated rectangular peak forward current

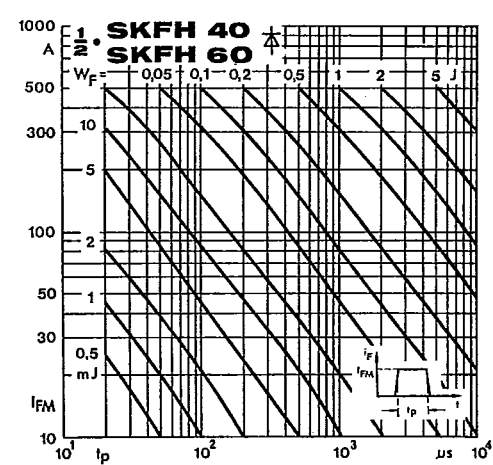

Fig. 15 a Forward energy dissipation, rectangular

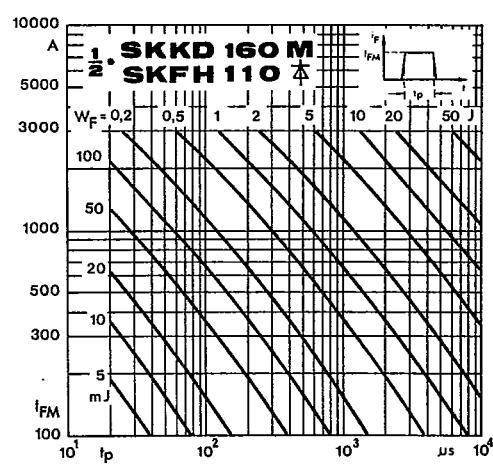

Fig. 15 b Forward energy dissipation, rectangular

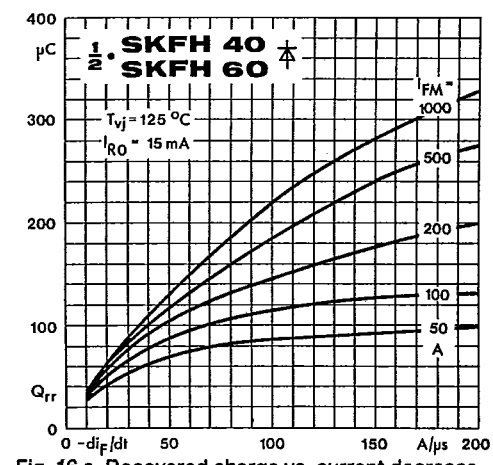

Fig. 16 a Recovered charge vs. current decrease

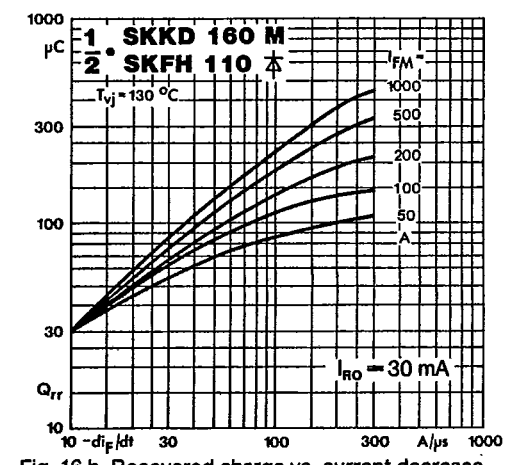

Fig. 16 b Recovered charge vs. current decrease

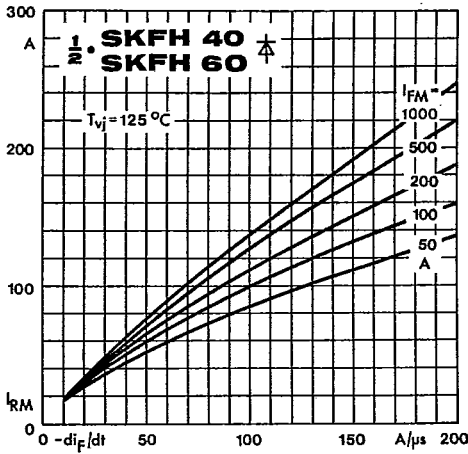

Fig. 17 a Peak recovery current vs. current decrease

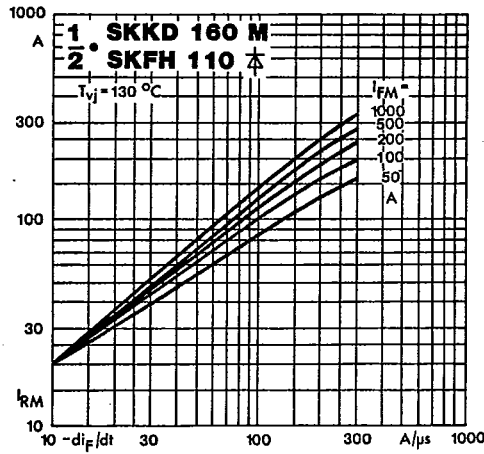

Fig. 17 b Peak recovery current vs. current decrease

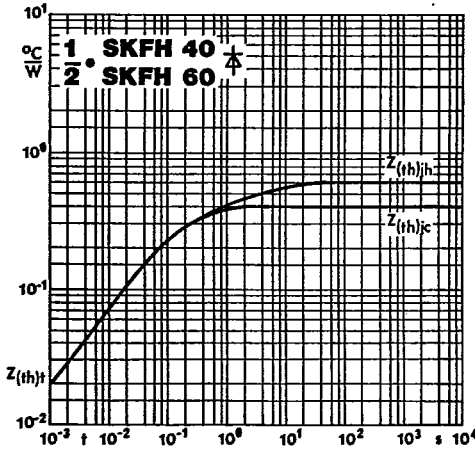

Fig. 18 a Transient thermal impedance vs. time

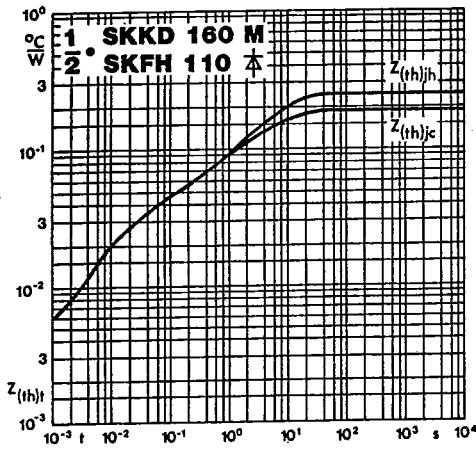

Fig. 18 b Transient thermal impedance vs. time

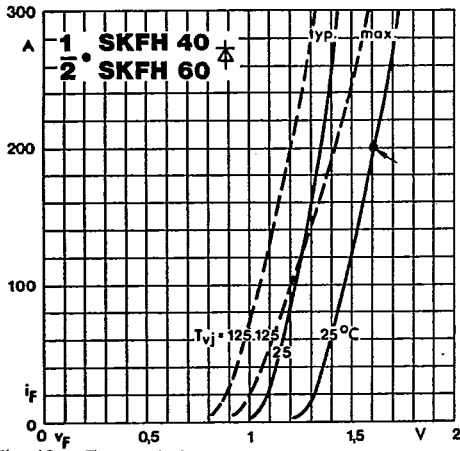

Fig. 19 a Forward characteristics

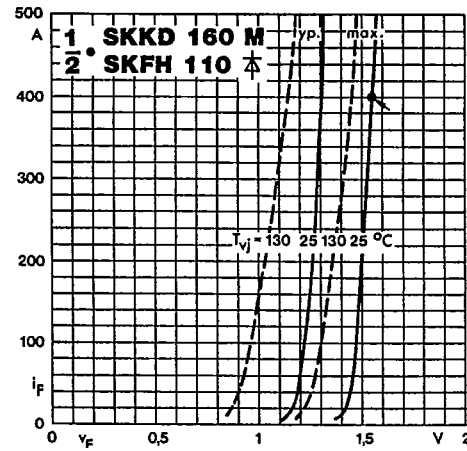

Fig. 19 b Forward characteristics

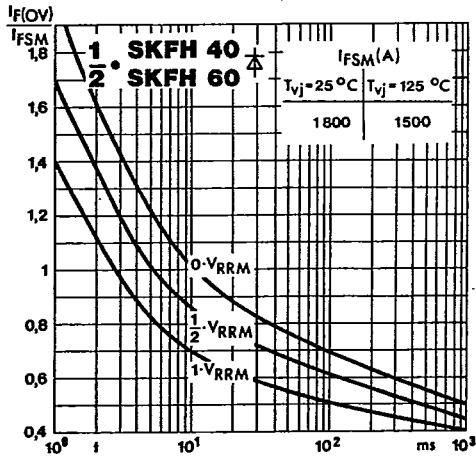

Fig. 20 a Surge overload current vs. time

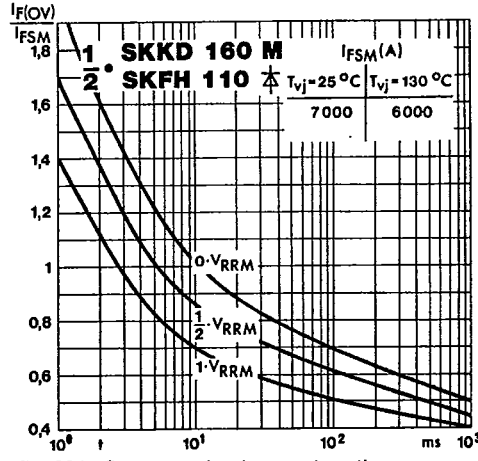

Fig. 20 b Surge overload current vs. time