

### Applications

- 5V to 3.3V translation in mixed-supply environment
- Hot-swap interface
- Logic replacement
- Bus isolation

### General Description

The VS3345 and VS32345 are high-speed TTL-compatible 8-bit bus switches. The VS3345 contains eight high-speed bus switches, with common active low (/OE) and active high (OE) enables. The low ON resistance of the VS3345 allows inputs to be connected to outputs, without adding propagation delay and without generating additional signal noise. The VS32345 has 25Ω resistors in series with the switches to reduce ground-bounce noise and signal reflection. The VS3345 and VS32345 bus switches enable 5V to 3.3V translation when used with a diode in the power supply line. In addition, the high off-isolation in the 'disable' mode makes VS3345 and VS32345 ideal interface elements for hot-swap applications.

### Features

- Enhanced N-FET with no DC path to V<sub>CC</sub> or GND in normal operating signal voltage range.
- Low impedance bidirectional data flow: 5Ω (VS3345) and 25Ω (VS32345)
- Near-zero propagation delay
- Zero added ground bounce or signal noise
- TTL-compatible control signals
- Undershoot clamp diodes on all switch and control pins
- ESD rating >2000V (Human Body Model) or >200V (Machine Model)
- Latch-up current >100mA
- Available in 150-mil wide QSOP package

**Figure 1. Functional Block Diagram**

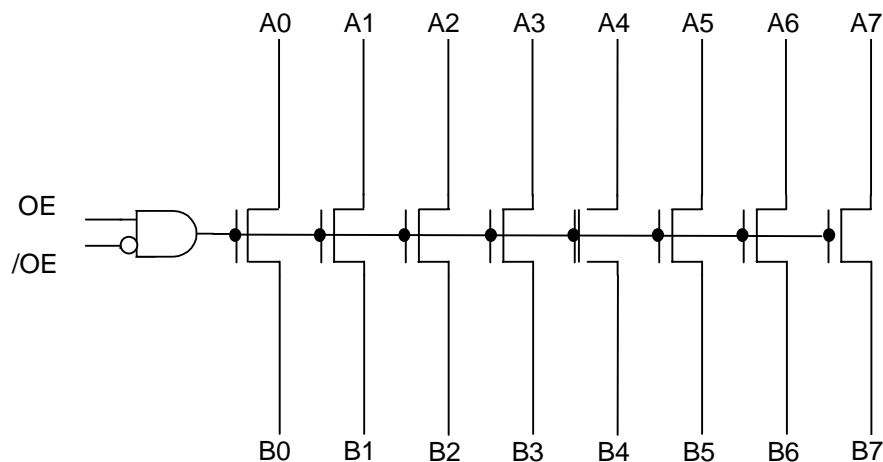

**Figure 2. Pin Configuration**

(All Pins Top View)

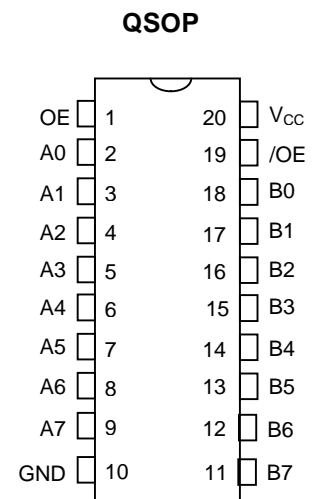

**Table 1. Pin Description**

Name	I/O	Description
A <sub>0</sub> - A <sub>7</sub>	I/O	Data Input or Output
/OE	I	Active Low Enable Input
OE	I	Active High Enable Input
B <sub>0</sub> - B <sub>7</sub>	I/O	Data Output or Input

**Table 2. Function Table**

Input		Path	Function
/OE	OE		
H	X	Hi Impedance	Disable all switches
X	L	Hi Impedance	Disable all switches
L	H	A <sub>n</sub> <-> B <sub>n</sub>	A <sub>n</sub> = B <sub>n</sub>

**Note:** X = Don't care

**Table 3. Absolute Maximum Ratings**

Supply Voltage to Ground.....	-0.5V to +7.0V
DC Switch Voltage V <sub>S</sub> .....	-0.5V to +7.0V
DC Input Voltage V <sub>IN</sub> .....	-0.5V to +7.0V
AC Input Voltage (Pulse Width < 20ns).....	-3.0V
DC Output Sink Current per Switch Pin.....	120 mA
Maximum Power Dissipation.....	0.5 Watts
Storage Temperature.....	-65°C to +150°C

**Note:** ABSOLUTE MAXIMUM CONTINUOUS RATINGS are those values beyond which damage to the device may occur. Exposure to these conditions or conditions beyond those indicated may adversely affect device reliability. Correct functional operation while operating in the absolute maximum rated conditions is not implied.

**Table 4. Capacitance**

T<sub>A</sub> = 25°C, f = 1 MHz, V<sub>IN</sub> = 0V, V<sub>OUT</sub> = 0V

Pins	QSOP		Unit
	Typ	Max	
Control Inputs	4	5	pF
VSwitch Channels (Switch OFF)	5	7	pF

**Note:** Capacitance is guaranteed, but not production tested. Total capacitance of a path, when the switch is closed, is the sum of the switch terminal capacitances.

**Table 5. Recommended Operating Conditions**

Symbol	Parameter	Conditions	Min	Typ	Max	Units
V <sub>CC</sub>	Power supply voltage		4.5		5.5	V
V <sub>IL</sub>	Low level input voltage		-0.5		0.8	V
V <sub>IH</sub>	High level input voltage		2.0		5.5	V
T <sub>A</sub>	Operating free-air temperature		-40		85	°C

**Table 6. Electrical Characteristics Over Recommended Operating Free-air Temperature Range**

Symbol	Parameter	Test Conditions		Min	Typ <sup>(1)</sup>	Max	Units
V <sub>IK</sub>	Clamp Voltage	Control Input	V <sub>CC</sub> = Min, I <sub>IK</sub> = -18 mA			-1.5	V
		Switch I/O				-1.5	
V <sub>OH</sub>	Logic High Voltage	Switch I/O	V <sub>IN</sub> = V <sub>CC</sub> = 5V, I <sub>OUT</sub> = -5μA	3.7	3.9	4.1	V
			V <sub>CC</sub> = 4.3V, V <sub>IN</sub> = 5V, I <sub>OUT</sub> = -5μA	3.0	3.3	3.6	
I <sub>I</sub>	Input Leakage Current	Control Input	V <sub>CC</sub> = Max, V <sub>I</sub> = V <sub>CC</sub> or GND			1	μA
I <sub>OFF</sub>	Power OFF Leakage Current	Control Input	V <sub>CC</sub> = 0, V <sub>I</sub> or V <sub>O</sub> = V <sub>CC</sub> or GND			1	μA
		Switch I/O					
I <sub>oz</sub>	OFF State Leakage Current	Switch I/O	V <sub>CC</sub> = Max, V <sub>I/O</sub> = V <sub>CC</sub> , /OE = V <sub>CC</sub> or OE = GND			1	μA
I <sub>ODL</sub>	Switch I/O Drive Current (Logic LOW)	V <sub>CC</sub> = Min, V <sub>IN</sub> = 0, V <sub>OUT</sub> = 0.4V	VS3345	50			mA
			VS32345				mA
I <sub>ODH</sub>	Switch I/O Drive Current (Logic HIGH)	V <sub>CC</sub> = Min, V <sub>IN</sub> = V <sub>CC</sub> , V <sub>OUT</sub> = 2.4V	VS3345	-50			mA
			VS32345				mA
R <sub>ON</sub>	Switch ON Resistance <sup>(2)</sup>	V <sub>CC</sub> = Min, V <sub>IN</sub> = 0, I <sub>OUT</sub> = 30mA	VS3345		5	7	Ω
			VS32345	20	28	40	Ω

**Notes:**

- Typical values are specified at V<sub>CC</sub> = 5.0V and T<sub>A</sub> = 25°C.
- R<sub>ON</sub> is measured by forcing specified current into the 'output' node of the switch with the 'input' node of the switch at the specified voltage

**Table 7. Power Supply Characteristics Over Recommended Operating Free-air Temperature Range**

Symbol	Parameter	Test Conditions <sup>(1)</sup>	Max	Units
I <sub>CCQ</sub>	Quiescent Power Supply Current	V <sub>CC</sub> = Max, /OE, OE = V <sub>CC</sub> or GND, f = 0	1	μA
ΔI <sub>CC</sub>	Power Supply Current per Input High (Control Input) <sup>(2)</sup>	V <sub>CC</sub> = Max, V <sub>IN</sub> = 3.4V, f = 0	1.5	mA
Q <sub>CCD</sub>	Dynamic Power Supply Current <sup>(3)</sup>	V <sub>CC</sub> = Max, Switch pins open, Control Inputs toggling at 50% duty cycle	0.25	mA/MHz

**Notes:**

- For conditions shown as Min or Max, use the appropriate values per *Recommended Operating Conditions*.
- Per TTL-driven control input. All other control inputs at GND. Switch I/O pins do not contribute to ΔI<sub>CC</sub>.
- This parameter represents the average DC current resulting from the switching of internal nodes of the device at a given frequency. The switch I/O pins make insignificant contribution to the dynamic power supply current of the device. This parameter is guaranteed, but not production tested.

Figure 3. VOLTAGE TRANSLATION

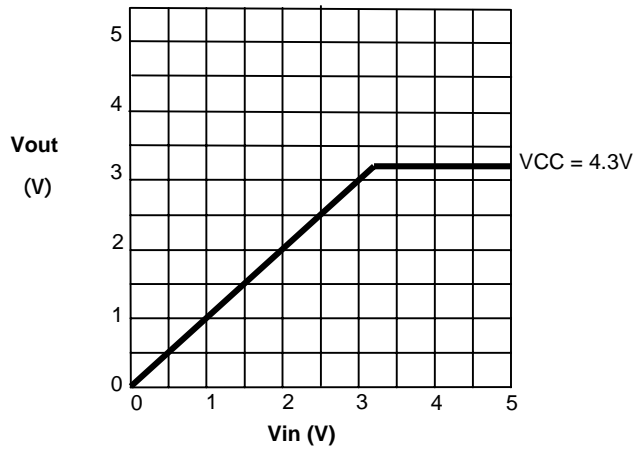

Figure 4. VOH CHARACTERISTICS

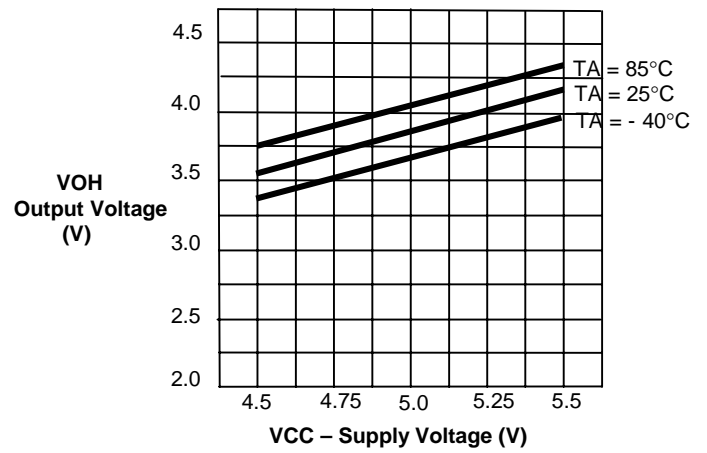
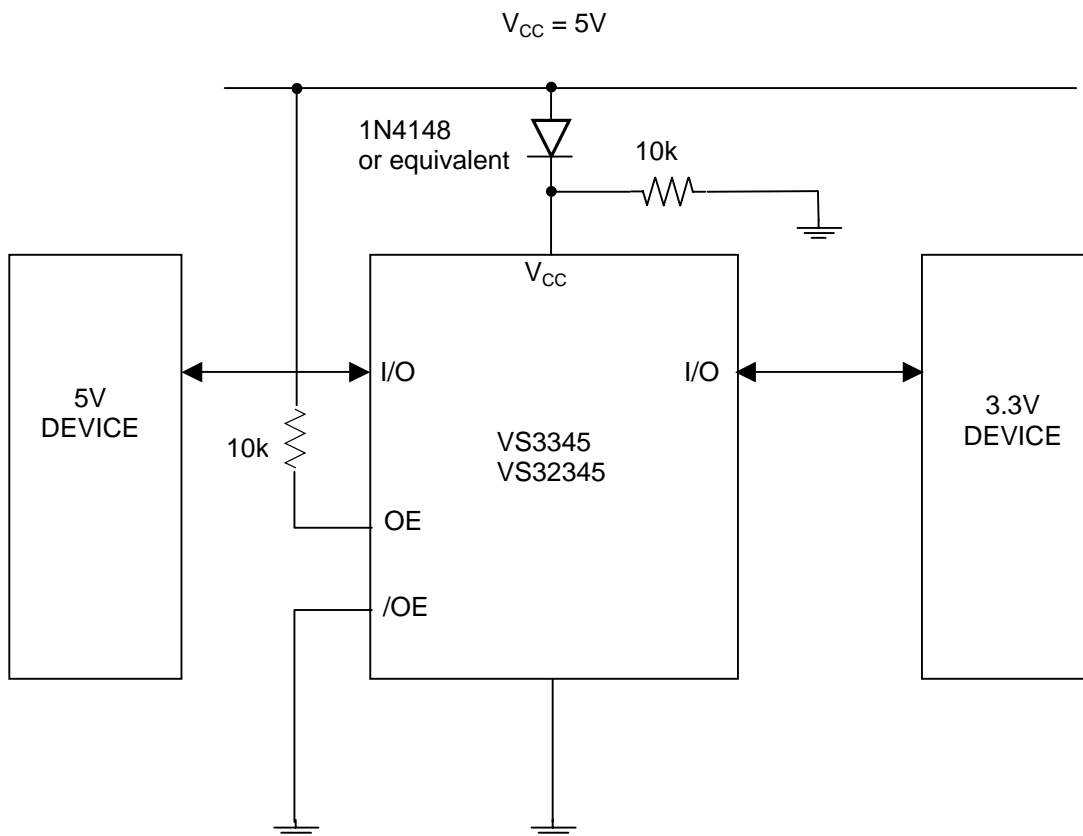

Figure 5. Voltage Translation Application



**Table 8. Switching Characteristics Over Operating Range**

$T_A = -40^{\circ}\text{C}$  to  $+85^{\circ}\text{C}$ ,  $V_{CC} = 5.0\text{V} \pm 10\%$   
 $C_{LOAD} = 50\text{pF}$ ,  $R_{LOAD} = 500\Omega$  unless otherwise stated.

Symbol	Description <sup>(1)</sup>	VS3245		VS32245		Units
		Min <sup>(3)</sup>	Max	Min <sup>(3)</sup>	Max	
$t_{PLH}$ , $t_{PHL}$	Data Propagation Delay <sup>(2,3)</sup> through the switch		0.25		1.25	ns
$t_{PZH}$ , $t_{PZL}$	Switch Turn-on Delay: /OE, OE to $A_n$ , $B_n$	0.5	5.6	0.5	6.6	ns
$t_{PLZ}$ , $t_{PHZ}$	Switch Turn-off Delay: /OE, OE to $A_n$ , $B_n$	0.5	4.5	0.5	4.5	ns

**Notes:**

1. See test circuits and waveforms.
2. This parameter is the calculated theoretical RC time constant of ON-state resistance of the switch and the specified load capacitance when driven by an ideal voltage source (zero source impedance). This time-constant is on the order of 0.25 ns for VS3345 and 1.25 ns for VS32345. Since this time-constant is much smaller than rise/fall times of typical driving signals, it adds very little propagation delay to the system.
3. This parameter is guaranteed, but not production tested.

**Figure 6. AC Test Circuit and Switching Waveforms**

**AC Test Circuit**

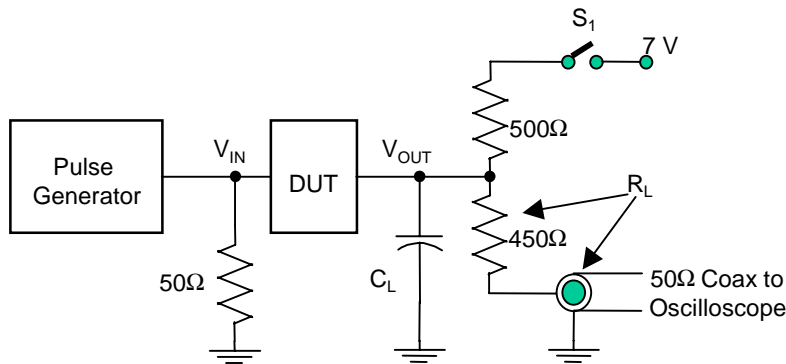

**Load Switch Position**

TEST	S1
$t_{PLH}$ , $t_{PHL}$	Open
$t_{PLZ}$ , $t_{PZL}$	Closed
$t_{PHZ}$ , $t_{PZH}$	Open

**Input Conditions**

Input voltage = 0 V to 3.0 V  
 $t_r = t_f = 2.5\text{ns}$  (10% to 90%)

Switching Waveforms

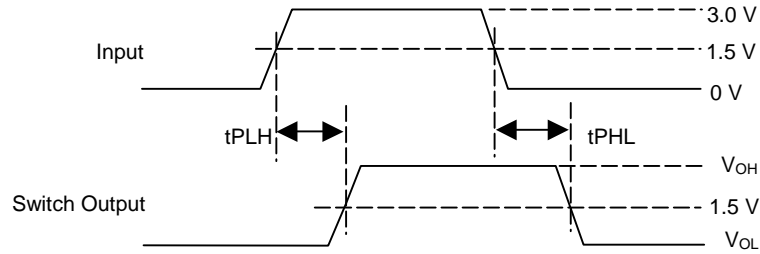

Propagation Delay

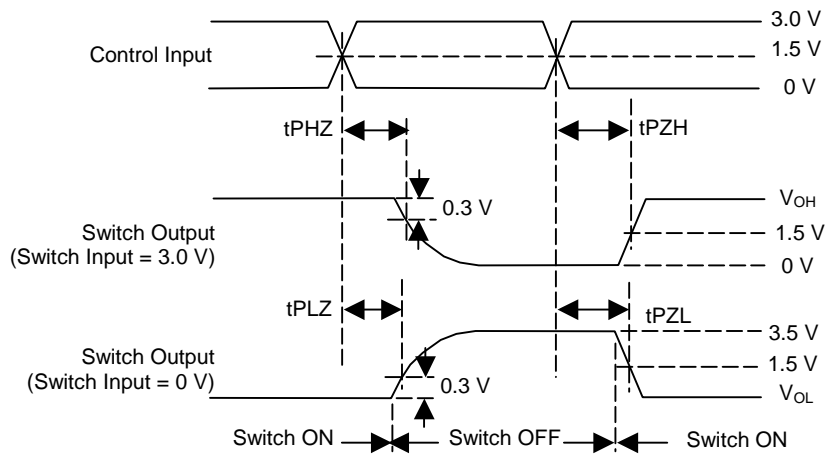

Enable and Disable Times

Ordering Information

Part Number	No. of Pins	Package	Temperature
VS3345Q	20	QSOP	-40°C to +85°C
VS32345Q	20	QSOP	-40°C to +85°C