

### Applications

- 5V to 3.3V translation in mixed-supply environment
- Hot-swap interface
- Logic replacement
- Bus isolation

### General Description

The VS3245 and VS32245 are high-speed TTL-compatible 8-bit bus switches. The VS3245 contains eight high-speed bus switches, with a common active low enable (/OE). The low ON resistance of the VS3245 allows inputs to be connected to outputs, without adding propagation delay and without generating additional signal noise. The VS32245 has 25Ω resistors in series with the switches to reduce ground-bounce noise and signal reflection.

The VS3245 and VS32245 bus switches are function and pinout compatible with QS3245 and CBT3245 switches. They enable 5V to 3.3V translation when used with a diode in the power supply line. In addition, the high off-isolation in the 'disable' mode makes VS3245 and VS32245 ideal interface elements for hot-swap applications.

### Features

- Enhanced N-FET with no DC path to V<sub>CC</sub> or GND in normal operating signal voltage range.
- Low impedance bidirectional data flow: 5Ω (VS3245) and 25Ω (VS32245)
- Pin-compatible with QS3245 and CBT3245 switches.
- Near-zero propagation delay
- Zero added ground bounce or signal noise
- TTL-compatible control signals
- Undershoot clamp diodes on all switch and control pins
- ESD rating >2000V (Human Body Model) or >200V (Machine Model)
- Latch-up current >100mA
- Available in 150-mil wide QSOP package

**Figure 1. Functional Block Diagram**

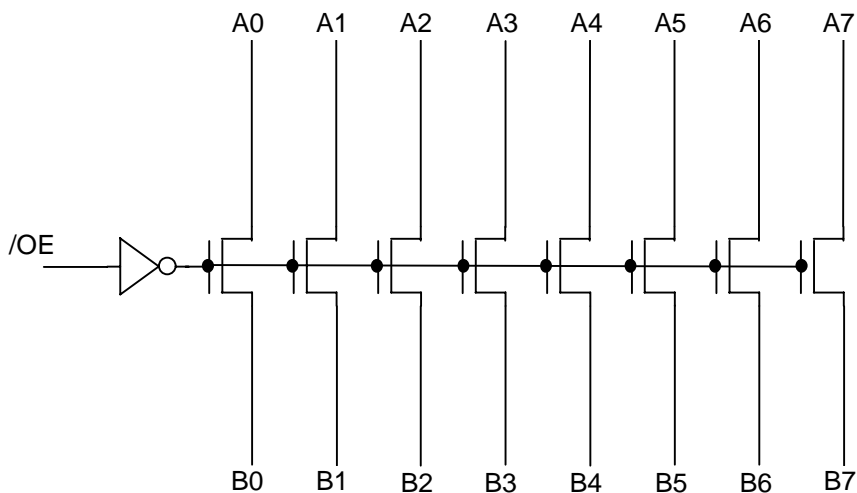

**Figure 2. Pin Configuration**

(All Pins Top View)

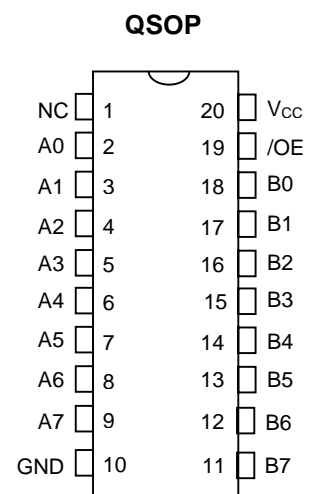

**Table 1. Pin Description**

| Name                            | I/O | Description          |
|---------------------------------|-----|----------------------|
| A <sub>0</sub> - A <sub>7</sub> | I/O | Data Input or Output |
| /OE                             | I   | Enable Input         |
| B <sub>0</sub> - B <sub>7</sub> | I/O | Data Output or Input |

**Table 2. Function Table**

| Input | Path                              | Function                        |
|-------|-----------------------------------|---------------------------------|
| /OE   |                                   |                                 |
| H     | Hi Impedance                      | Disable all switches            |
| L     | A <sub>n</sub> <-> B <sub>n</sub> | A <sub>n</sub> = B <sub>n</sub> |

**Table 3. Absolute Maximum Ratings**

|  |                 |
|--|-----------------|
| Supply Voltage to Ground.....              | -0.5V to +7.0V  |
| DC Switch Voltage V <sub>s</sub> .....     | -0.5V to +7.0V  |
| DC Input Voltage V <sub>IN</sub> .....     | -0.5V to +7.0V  |
| AC Input Voltage (Pulse Width < 20ns)..... | -3.0V           |
| DC Output Sink Current per Switch Pin..... | 120 mA          |
| Maximum Power Dissipation.....             | 0.5 Watts       |
| Storage Temperature.....                   | -65°C to +150°C |

**Note** ABSOLUTE MAXIMUM CONTINUOUS RATINGS are those values beyond which damage to the device may occur. Exposure to these conditions or conditions beyond those indicated may adversely affect device reliability. Correct functional operation while operating in the absolute maximum rated conditions is not implied.

**Table 4. Capacitance**

T<sub>A</sub> = 25°C, f = 1 MHz, V<sub>IN</sub> = 0V, V<sub>OUT</sub> = 0V

| Pins                             | QSOP |     | Unit |
|----------------------------------|------|-----|------|
|                                  | Typ  | Max |      |
| Control Inputs                   | 4    | 5   | pF   |
| VSwitch Channels<br>(Switch OFF) | 5    | 7   | pF   |

**Note** Capacitance is guaranteed, but not production tested. Total capacitance of a path, when the switch is closed, is the sum of the switch terminal capacitances.

Table 5. Recommended Operating Conditions

| Symbol          | Parameter                      | Conditions | Min  | Typ | Max | Units |
|-----------------|--------------------------------|------------|------|-----|-----|-------|
| V <sub>CC</sub> | Power supply voltage           |            | 4.5  |     | 5.5 | V     |
| V <sub>IL</sub> | Low level input voltage        |            | -0.5 |     | 0.8 | V     |
| V <sub>IH</sub> | High level input voltage       |            | 2.0  |     | 5.5 | V     |
| T <sub>A</sub>  | Operating free-air temperature |            | -40  |     | 85  | °C    |

Table 6. Electrical Characteristics Over Recommended Operating Free-air Temperature Range

| Symbol           | Parameter                             | Test Conditions   |  | Min | Typ <sup>(1)</sup> | Max  | Units |
|------------------|---------------------------------------|---|--|-----|--------------------|------|-------|
| V <sub>IK</sub>  | Clamp Voltage                         | Control Input   | V <sub>CC</sub> = Min, I <sub>IK</sub> = -18 mA                                      |     |                    | -1.5 | V     |
|                  |                                       | Switch I/O  |  |     |                    | -1.5 |       |
| V <sub>OH</sub>  | Logic High Voltage                    | Switch I/O  | V <sub>IN</sub> = V <sub>CC</sub> = 5V, I <sub>OUT</sub> = -5μA                      | 3.7 | 3.9                | 4.1  | V     |
|                  |                                       |   | V <sub>CC</sub> = 4.3V, V <sub>N</sub> = 5V,<br>I <sub>OUT</sub> = -5μA              | 3.0 | 3.3                | 3.6  |       |
| I <sub>I</sub>   | Input Leakage Current                 | Control Input   | V <sub>CC</sub> = Max, V <sub>I</sub> = V <sub>CC</sub> or GND                       |     |                    | 1    | μA    |
| I <sub>OFF</sub> | Power OFF Leakage Current             | Control Input   | V <sub>CC</sub> = 0,<br>V <sub>I</sub> or V <sub>O</sub> = V <sub>CC</sub> or GND    |     |                    | 1    | μA    |
|                  |                                       | Switch I/O  |  |     |                    |      |       |
| I <sub>oz</sub>  | OFF State Leakage Current             | Switch I/O  | V <sub>CC</sub> = Max, V <sub>I/O</sub> = V <sub>CC</sub> ,<br>/OE = V <sub>CC</sub> |     |                    | 1    | μA    |
| I <sub>ODL</sub> | Switch I/O Drive Current (Logic LOW)  | V <sub>CC</sub> = Min, V <sub>IN</sub> = 0,<br>V <sub>OUT</sub> = 0.4V                | VS3245   | 50  |                    |      | mA    |
|                  |                                       |   | VS32245  |     |                    |      | mA    |
| I <sub>ODH</sub> | Switch I/O Drive Current (Logic HIGH) | V <sub>CC</sub> = Min, V <sub>IN</sub> = V <sub>CC</sub> ,<br>V <sub>OUT</sub> = 2.4V | VS3245   | -50 |                    |      | mA    |
|                  |                                       |   | VS32245  |     |                    |      | mA    |
| R <sub>ON</sub>  | Switch ON Resistance <sup>(2)</sup>   | V <sub>CC</sub> = Min, V <sub>IN</sub> = 0,<br>I <sub>OUT</sub> = 30mA                | VS3245   |     | 5                  | 7    | Ω     |
|                  |                                       |   | VS32245  | 20  | 28                 | 40   | Ω     |

**Notes:**

- Typical values are specified at V<sub>CC</sub> = 5.0V and T<sub>A</sub> = 25°C.
- R<sub>ON</sub> is measured by forcing specified current into the 'output' node of the switch with the 'input' node of the switch at the specified voltage

Table 7. Power Supply Characteristics Over Recommended Operating Free-air Temperature Range

| Symbol           | Parameter  | Test Conditions <sup>(1)</sup>  | Max  | Units  |
|------------------|--|---|------|--------|
| I <sub>CCQ</sub> | Quiescent Power Supply Current                                     | V <sub>CC</sub> = Max, /OE = V <sub>CC</sub> or GND, f = 0                            | 1    | μA     |
| ΔI <sub>CC</sub> | Power Supply Current per Input High (Control Input) <sup>(2)</sup> | V <sub>CC</sub> = Max, V <sub>IN</sub> = 3.4V, f = 0                                  | 1.5  | mA     |
| Q <sub>CCD</sub> | Dynamic Power Supply Current <sup>(3)</sup>                        | V <sub>CC</sub> = Max, Switch pins open,<br>Control Inputs toggling at 50% duty cycle | 0.25 | mA/MHz |

**Notes:**

- For conditions shown as Min or Max, use the appropriate values per *Recommended Operating Conditions*.
- Per TTL-driven control input. All other control inputs at GND. Switch I/O pins do not contribute to ΔI<sub>CC</sub>.
- This parameter represents the average DC current resulting from the switching of internal nodes of the device at a given frequency. The switch I/O pins make insignificant contribution to the dynamic power supply current of the device. This parameter is guaranteed, but not production tested.

**Figure 3. VOLTAGE TRANSLATION**

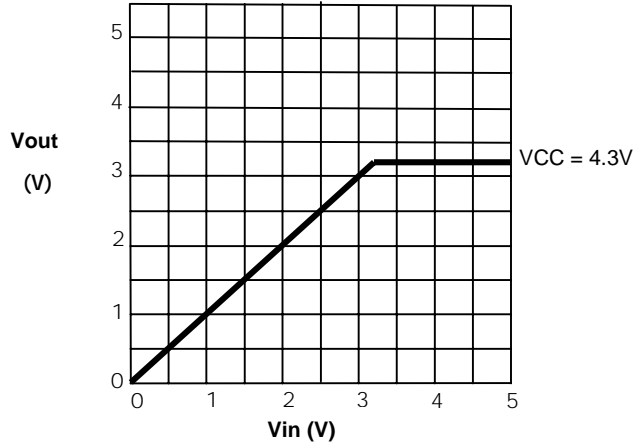

**Figure 4. VOH CHARACTERISTICS**

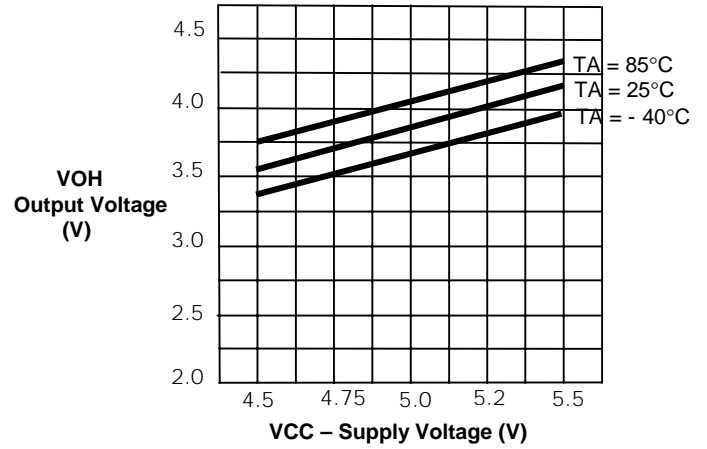

**Figure 5. Voltage Translation Application**

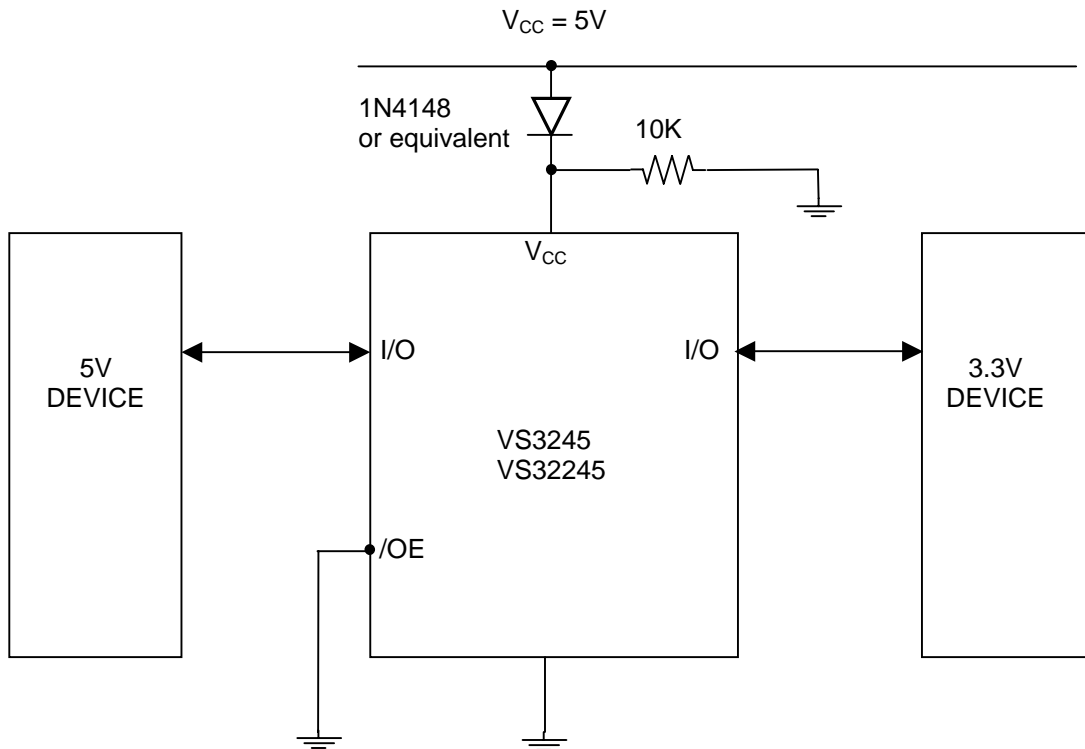

**Table 8. Switching Characteristics Over Operating Range**

$T_A = -40^{\circ}\text{C}$  to  $+85^{\circ}\text{C}$ ,  $V_{CC} = 5.0\text{V} \pm 10\%$   
 $C_{LOAD} = 50\text{pF}$ ,  $R_{LOAD} = 500\Omega$  unless otherwise stated.

| Symbol                | Description <sup>(1)</sup>                                 | VS3245             |      | VS32245            |      | Units |
|-----------------------|--|--------------------|------|--------------------|------|-------|
|                       |  | Min <sup>(3)</sup> | Max  | Min <sup>(3)</sup> | Max  |       |
| $t_{PLH}$ , $t_{PHL}$ | Data Propagation Delay <sup>(2,3)</sup> through the switch |                    | 0.25 |                    | 1.25 | ns    |
| $t_{PZH}$ , $t_{PZL}$ | Switch Turn-on Delay, /OE to $A_n$ , $B_n$                 | 0.5                | 5.6  | 0.5                | 6.6  | ns    |
| $t_{PLZ}$ , $t_{PHZ}$ | Switch Turn-off Delay /OE to $A_n$ , $B_n$                 | 0.5                | 4.5  | 0.5                | 4.5  | ns    |

**Notes:**

1. See test circuits and waveforms.
2. This parameter is the calculated theoretical RC time constant of ON-state resistance of the switch and the specified load capacitance when driven by an ideal voltage source (zero source impedance). This time-constant is on the order of 0.25 ns for VS3245 and 1.25 ns for VS32245. Since this time-constant is much smaller than rise/fall times of typical driving signals, it adds very little propagation delay to the system.
3. This parameter is guaranteed, but not production tested.

**Figure 6. AC Test Circuit and Switching Waveforms**

**AC Test Circuit**

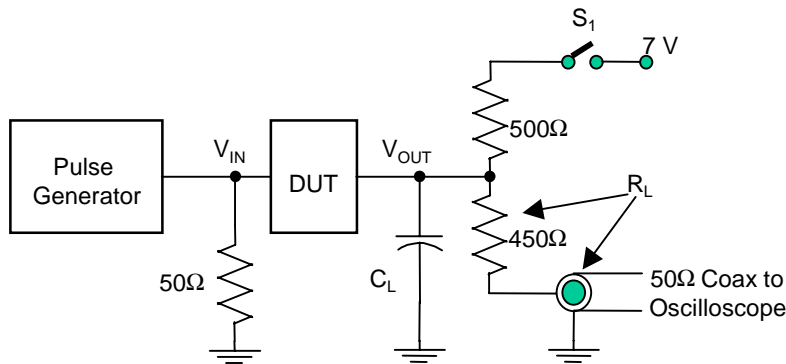

**Load Switch Position**

| TEST                  | S1     |
|-----------------------|--------|
| $t_{PLH}$ , $t_{PHL}$ | Open   |
| $t_{PLZ}$ , $t_{PZL}$ | Closed |
| $t_{PHZ}$ , $t_{PZH}$ | Open   |

**Input Conditions**

Input voltage = 0 V to 3.0 V  
 $t_r = t_f = 2.5\text{ns}$  (10% to 90%)

Switching Waveforms

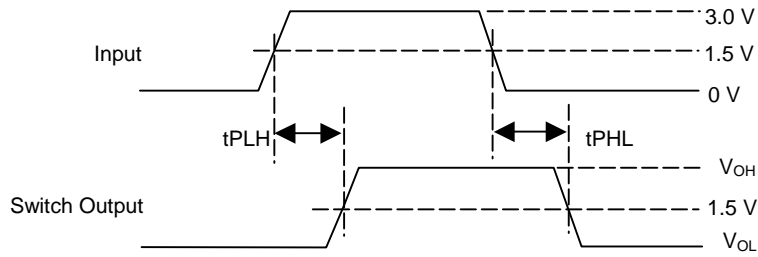

Propagation Delay

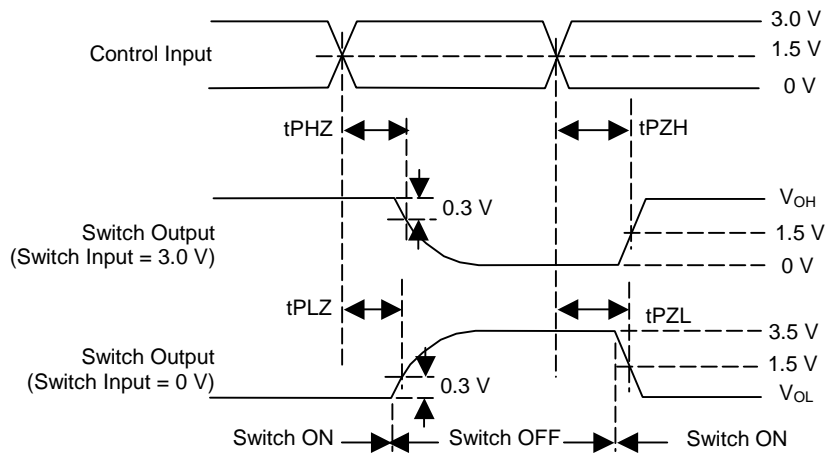

Enable and Disable Times

Ordering Information

| Part Number | Marking  | Shipping/Packaging | No. of Pins | Package | Temperature    |
|-------------|----------|--------------------|-------------|---------|----------------|
| VS3245Q     | VS3245Q  | Tubes              | 20          | QSOP    | -40°C to +85°C |
| VS3245QX    | VS3245Q  | Tape & Reel        | 20          | QSOP    | -40°C to +85°C |
| VS32245Q    | VS32245Q | Tubes              | 20          | QSOP    | -40°C to +85°C |
| VS32245QX   | VS32245Q | Tape & Reel        | 20          | QSOP    | -40°C to +85°C |