

## Features

- Programmable line impedance matching
- Internal complex impedance networks
- Transformerless 2-4 wire conversion
- Programmable transmit/receive gain
- Accommodates worldwide transmission standards
- Operates with a wide range of battery voltages
- Adjustable constant current battery feed
- Overvoltage and short circuit protection
- Switch hook and ground button detection
- Ring trip filter and relay driver
- Low power consumption
- High power dissipation capability during fault conditions

ISSUE 7

April 1995

### Ordering Information

MH88600      40 Pin DIL Hybrid

**0°C to 70°C**

## Description

The MH88600 is a SLIC (Subscriber Line Interface Circuit) which provides all of the BORSCH functions of Battery Feed, Overvoltage Protection, Ringing Feed, Line Supervision and 2-4 Wire Hybrid conversion. In addition, the device matches the many different line impedances specified by regulatory authorities of around the world.

## Applications

Line interface for:

- PABXs
- Control Systems
- Key Telephone Systems
- Central Office Equipment

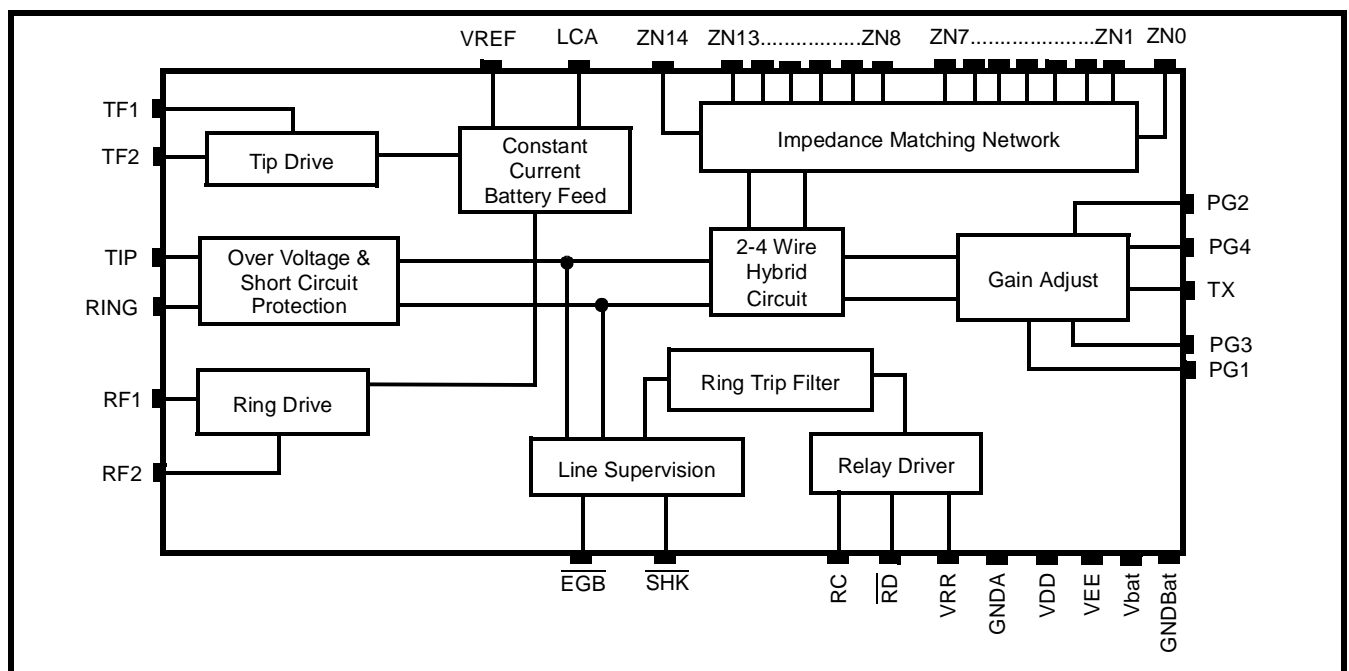
**Figure 1 - Functional Block Diagram**

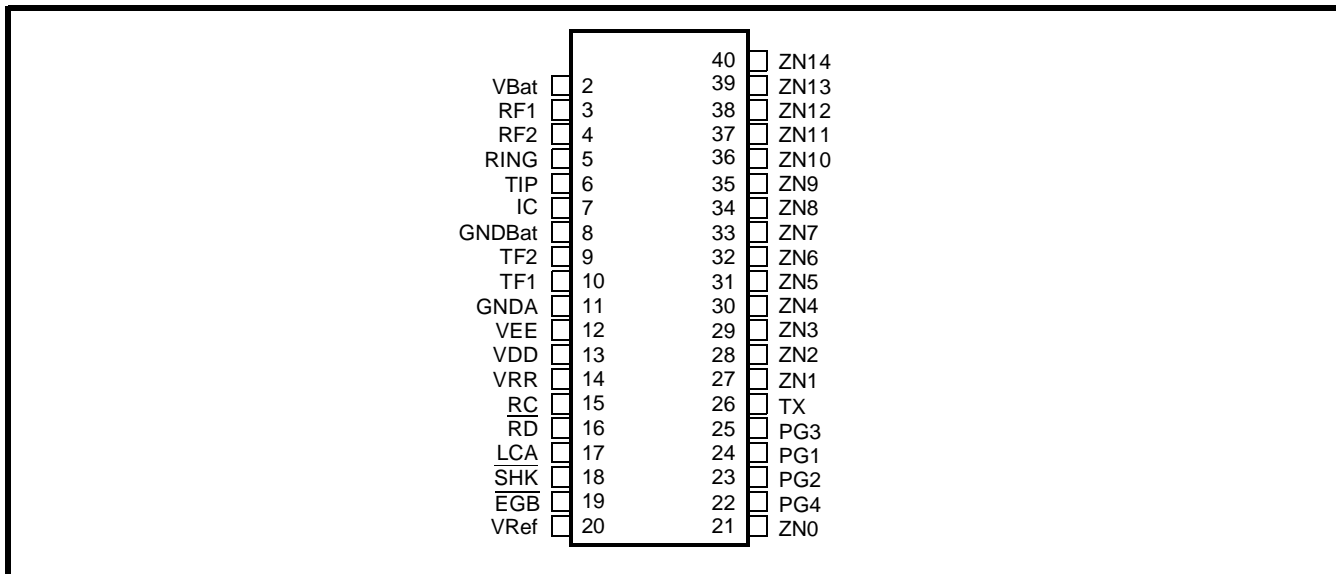

Figure 2 - Pin Connections

## Pin Description

Pin #	Name	Description
1		No pin at this location.
2	V <sub>Bat</sub>	<b>Battery Supply Voltage (Negative).</b>
3	RF1	<b>Ring Feed (1):</b> Connect to relay contact. See Figures 6 & 7.
4	RF2	<b>Ring Feed (2):</b> Connect to relay contact. See Figures 6 & 7.
5	RING	Connects to the “Ring” or “B” lead of the telephone line.
6	TIP	Connects to the “Tip” or “A” lead of the telephone line.
7	I/C	<b>Internal Connection.</b>
8	GND <sub>Bat</sub>	<b>Battery Supply Ground (Positive):</b> Connect to System Ground
9	TF2	<b>Tip Feed (2):</b> Connect to TF1 for unbalanced ringing, see Figure 6. Connect to relay contact for balanced ringing, see Figure 7.
10	TF1	<b>Tip Feed (1):</b> Connect to TF2 for unbalanced ringing, see Figure 6. Connect to relay contact for balanced ringing, see Figure 7.
11	GNDA	<b>Analog Ground:</b> Normally connected to System Ground.
12	V <sub>EE</sub>	<b>Negative Power Supply Voltage:</b> Normally -5V.
13	V <sub>DD</sub>	<b>Positive Power Supply Voltage:</b> Normally +5V.
14	V <sub>RR</sub>	<b>Ringing Relay Clamp Diode:</b> Connect to relay coil and to relay supply voltage (Positive). For +5V relay, connect to VDD.
15	RC	<b>Ring Control (Input):</b> A logic high will activate the Ring Relay Drive if $\overline{\text{SHK}}$ is high.
16	$\overline{\text{RD}}$	<b>Ring Relay Drive (Output):</b> Connect to relay coil. A logic low will activate the relay by sinking current from VRR through the relay coil.
17	LCA	<b>Loop Current Adjust (Input):</b> Loop current is proportional to the voltage at this input. Normally connected to V <sub>Ref</sub>
18	$\overline{\text{SHK}}$	<b>Switch Hook Detect (Output):</b> A logic low indicates an off-hook condition.
19	$\overline{\text{EGB}}$	<b>Earth Ground Button (Output):</b> A logic low indicates a grounded Ring lead condition.
20	V <sub>Ref</sub>	<b>Voltage Reference (Output):</b> Normally connected to LCA for default loop current.

**Pin Description (Continued)**

Pin #	Name	Description
21	ZN0	<b>Impedance Node 0:</b> Connect to external network for impedance ( $Z_{in}$ ) setting. See Table 2 and Figure 8.
22	PG4	<b>Programming 4 (Input).</b> Used for programmable gain and for default gain. Used as 4-Wire Receive Input for default gain. See Table 3 and Figure 4 and 5.
23	PG2	<b>Programming 2 (Input).</b> Used for programmable gain. Used with resistor for 4-Wire Receive Input. See Table 3 and Figure 4.
24	PG1	<b>Programming 1 (Input).</b> Used for programmable gain. See Table 3 and Figure 4.
25	PG3	<b>Programming 3 (Input).</b> Used for programmable gain and for default gain. See Table 3 and Figure 4 and 5.
26	TX	<b>4-Wire Transmit Output:</b>
27	ZN1	<b>Impedance Node 1:</b> Connect to other Impedance Nodes for impedance ( $Z_{in}$ ) setting, see Table 1. Or, connect to external network for impedance ( $Z_{in}$ ) setting, see Table 2 and Figure 8.
28	ZN2	<b>Impedance Node 2:</b> Connect to other impedances Nodes for impedance ( $Z_{in}$ ) setting. See Table 1.
29	ZN3	<b>Impedance Node 3:</b> As per ZN2. See Table 1.
30	ZN4	<b>Impedance Node 4:</b> As per ZN2. See Table 1
31	ZN5	<b>Impedance Node 5:</b> As per ZN2. See Table 1
32	ZN6	<b>Impedance Node 6:</b> As per ZN2. See Table 1
33	ZN7	<b>Impedance Node 7:</b> As per ZN2. See Table 1
34	ZN8	<b>Impedance Node 8:</b> As per ZN2. See Table 1
35	ZN9	<b>Impedance Node 9:</b> As per ZN2. See Table 1
36	ZN10	<b>Impedance Node 10:</b> As per ZN2. See Table 1
37	ZN11	<b>Impedance Node 11:</b> As per ZN2. See Table 1
38	ZN12	<b>Impedance Node 12:</b> As per ZN2. See Table 1
39	ZN13	<b>Impedance Node 13:</b> As per ZN2. See Table 1
40	ZN14	<b>Impedance Node 14:</b> Connect to external network for impedance ( $Z_{in}$ ) setting. See Table 2 and Figure 8.

## Functional Description

### The BORSH Functions

The MH88600 performs all of the BORSH functions; Battery Feed, Overvoltage Protection, Ringing, Supervision and Hybrid.

### Battery Feed

The MH88600 provides the loop with constant DC current to power the telephone set. The voltage (negative) applied at the LCA pin determines the magnitude of the loop current.

$$I_{\text{Loop}} = 3.731 \times \text{VLCA mA } (\pm 2\text{mA})$$

Either the internal ( $V_{\text{Ref}}$ ) or an external negative voltage reference may be used to set the loop current.

### Overvoltage Protection

The MH88600 is protected from short term (20ms) transients (+250V) between Tip and Ring, Tip and ground, and Ring and Ground. However, additional protection circuitry may be needed depending on the regulatory requirements which must be met. Normally, simple external shunt protection as shown in Figures 6,7 and 8 is all that is required.

### Ringing

The MH88600 has the capability to accommodate both balanced and unbalanced ringing sources. Refer to Figure 7 for the Balanced Ringing Circuit and Figure 6 for the Unbalanced Ringing Circuit.

### Supervision

The MH88600 is capable of detecting both Ground Button and Switch Hook conditions. The Ground Button detection (a logic low at the  $\overline{\text{EGB}}$  output) operates when an imbalance in Tip and Ring DC current exceeds an internal threshold level caused by a grounded Ring Lead. Use of the  $\overline{\text{EGB}}$  output is restricted to the off-hook condition of the telephone. The Switch Hook detection operates (a logic low at the  $\overline{\text{SHK}}$  output) when the DC loop current exceeds an internal threshold level.

The Ring Trip Detection Circuit prevents false off-hook detection due to the current associated with the AC ringing voltage and also due to the large current transients when the ring voltage is switched in and out. In addition, the circuit prevents connection of the ringing source during off-hook conditions.

## Hybrid

The 2-4 Wire Hybrid circuit separates the balanced full duplex signal at Tip and Ring of the telephone line into receive and transmit ground referenced signals at RX (receive) and TX (transmit) of the SLIC. The Hybrid also prevents the input signal at RX from appearing at TX. The degree to which the Hybrid prevents the RX signal from appearing at TX is specified at transhybrid loss.

## Tip-Ring Drive Circuit

The audio input ground referenced signal at RX is converted to a balanced output signal at Tip and Ring. The output signal consists of the audio signal superimposed on the DC Battery Feed Constant Current. The Tip-Ring Drive Circuit is optimised for good 2-Wire longitudinal balance.

## Short Circuit Protection

The MH88600 is protected from long term (infinite) short circuit conditions occurring between Tip and Ring, Tip and Ground, Ring and Ground, and Ring and Battery. The current is limited to the same value as the Constant Current Battery Feed.

## Programmable Line Impedance

The MH88600's Tip-Ring ( $Z_{\text{in}}$ ) impedance can be matched to the different impedances specified by different telephone administrations worldwide. This is accomplished by either linking specific pins as specified in Table 1, or by adding external components as shown in Figure 8 and Table 2.

## Programmable Transmit & Receive Gain

Transmit gain (TX to Tip-Ring) and Receive Gain (Tip-Ring to RX) can be programmed by connecting external resistors as indicated in Figure 4 and Table 3. Alternatively, the default Receive Gain of -4d Band Transmit Gain of +4dB can be obtained by connecting pins as shown in figure 5 and Table3.

Note that RX is not a pin on the SLIC. The RX terminal will be either PG4 or the connection to the receive gain programming resistor RRX shown in Figure 4 and Figure 5.

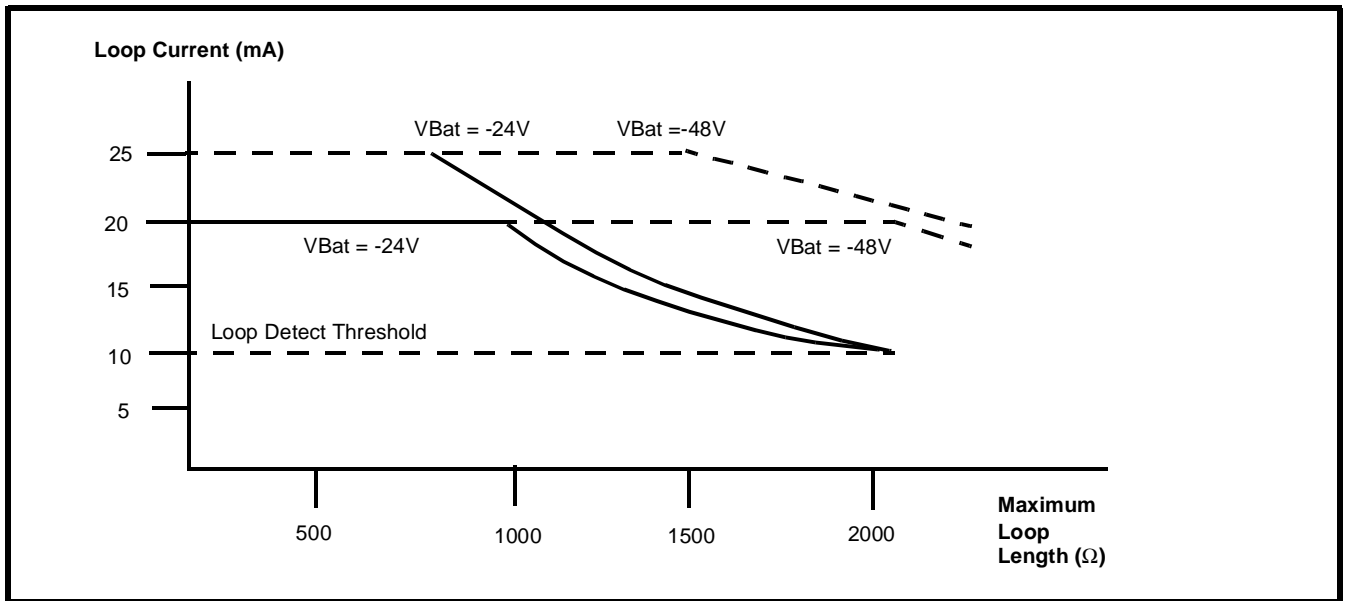

Figure 3a - Loop Current vs. Maximum Loop Length

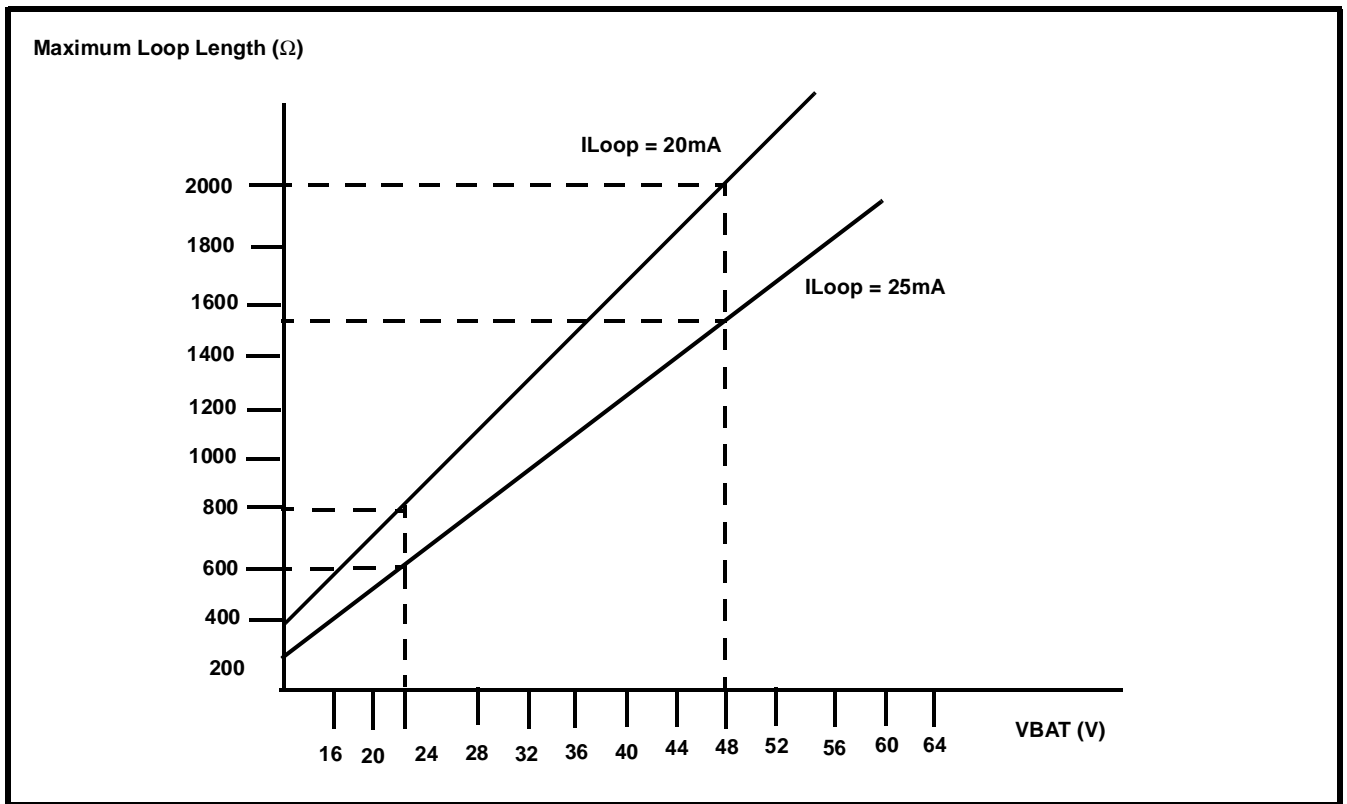

Figure 3b - Maximum Loop Length vs Battery voltage

**Absolute Maximum Ratings\*** - Voltages are with respect to AGND.

	Parameters	Sym	Min.	Max	Units
1	DC Supply Voltages  (GND <sub>A</sub> = GND <sub>Bat</sub> )	V <sub>DD</sub>	-0.3	15	V
		V <sub>EE</sub>	+0.3	-15	V
		V <sub>Bat</sub>	+0.3	-80	V
		V <sub>RR</sub>	-0.3	40	V
2	Storage Temperature	T <sub>S</sub>	-55	125	°C
3	Power Dissipation	P <sub>D</sub>		4	W

\* Exceeding these values may cause permanent damage. Functional operation under these conditions is not implied.

**Recommended Operating Conditions**

	Characteristics	Sym	Min.	Typ*	Max	Units	Comments
1	Operating Supply Voltage	V <sub>DD</sub>	4.75	5.0	5.25	V	
		V <sub>EE</sub>	-5.25	-5.0	-4.75	V	
		V <sub>Bat</sub>	-72	-48	-24	V	
		V <sub>RR</sub>		5	24	V	
2	Operating Temperature	T <sub>OP</sub>	0		70	°C	

\* Typical figures are at 25°C and are for design aid only: not guaranteed and not subject to production testing.

## DC Electrical Characteristics †

		Parameters	Sym	Min.	Typ*	Max	Units	Test Conditions
1		Supply Current	$I_{DD}$ $I_{EE}$ $I_{Bat}$		8.5 5.0	12.0 10.0 4.8	mA mA mA	$R_{Loop}$ =Open Cct, $V_{Bat} = -48V$
2		Power Consumption	PC			330 755 1556	mW mW mW	Standby $R_{Loop}$ =1200 $\Omega$ $R_{Loop}$ =0 $\Omega$ $V_{Bat}$ =-48V
3		Constant Current Battery Feed ‡	$I_{Loop}$ $I_{Loop}$	18 21	20 25	22 30	mA mA	LCA=-5.4V when $R_{Loop}$ =0 $\Omega$ LCA=linked to $V_{Ref}$ when $R_{Loop}$ =0 $\Omega$
4		Operating Loop Resistance†	$R_{Loop}$	2000 800 1560 600			$\Omega$ $\Omega$ $\Omega$ $\Omega$	$V_{Bat}$ =-48V, $I_{Loop}$ =20mA $V_{Bat}$ =-48V, $I_{Loop}$ =20mA $V_{Bat}$ =-48V, $I_{Loop}$ =25mA $V_{Bat}$ =-48V, $I_{Loop}$ =25mA
5		Off-Hook Detect Threshold	$SHK_{th}$		10		mA	
6		GND Button Detect Threshold	$EGB_{th}$		10		mA	
7		Ring GND Over-Current Protection			32	41	mA	
8	$\overline{SHK}$ &	Low Level Output Voltage High Level Output Voltage	$V_{OL}$ $V_{OH}$	2.4		0.4	V V	No Load
9	$\overline{EGB}$	Sink Current Source Current	$I_{OL}$ $I_{OH}$	160 390			$\mu A$ $\mu A$	$V_{OL} = 0.8V$ $V_{OH} = -0.2V$
10	RC	Low Level Input Voltage High Level Input Voltage	$V_{IL}$ $V_{IH}$	4.0		0.4	V V	
11		High Level Input Current	$I_{IH}$			1.5	mA	$V_{IH} = V_{DD}$
12	$\overline{RD}$	Sink Current	$I_{RLY}$	65			mA	
13		Clamp Diode Current	$I_{CD}$			65	mA	
14	$V_{Ref}$	Internal Reference		-7.4	-6.7	-6.0	V	LCA linked to $V_{Ref}$

\* Typical figures are at 25°C and are for design aid only: not guaranteed and not subject to production testing.

† DC Electrical Characteristics are over recommended operating conditions unless otherwise stated.

‡ See Figures 3a and 3b.

**AC Electrical Characteristics<sup>†</sup>** - Voltages are with respect to GNDA unless otherwise stated.

	Characteristics	Sym	Min.	Typ <sup>*</sup>	Max	Units	Test Conditions	
1	Ringer Voltage	VR			105	V <sub>rms</sub>	See Fig 6	
2	Ringer Equivalence No.	REN			5			
3	Ring Trip Detect Time				200	ms		
4	Input Impedance at PG4 at VRX	Z <sub>RX</sub>		112 RRX		kΩ	See Fig 5 See Fig 4	
5	Output Impedance at TX	Z <sub>TX</sub>		3		Ω		
6	Gain 2-Wire to TX: Fixed Gain Programmable Range Frequency Response Gain relative to Gain @ 1kHz  300Hz 600Hz and 2400Hz 3000Hz 3400Hz	A TX	+3.5	+4	+4.5	dB	Input 1.0V at 1kHz See Fig 5	
		RTX	-12		+6	dB	See Figure 4	
		A <sub>R</sub> TX						Input 1.0V 600Ω 2-Wire Impedance
			-0.75		0.1	dB		
			-0.1		0.1	dB		
7	Gain RX to 2-Wire: Fixed Gain Programmable Range Frequency Response Gain relative to Gain @ 1kHz  300Hz 600Hz and 2400Hz 3000Hz 3400Hz	ARX	-4.5	-4	-3.5	dB	Input 1.0V at 1kHz See Fig 5	
		RRX	-12		+6	dB	See Figure 4	
		A <sub>R</sub> RX						Input 1.0V 600Ω 2-Wire Impedance
			-0.75		0.1	dB		
			-0.1		0.1	dB		
8	2-Wire Return Loss	RL	20	26		dB	Input 1.0V, 200Hz to 3.4kHz Input 1.0V, 3.4kHz to 4kHz	
			18			dB		
9	2-Wire Input Impedance	Z <sub>IN</sub>					See Table 1	
10	Transhybrid Loss	THL	20	40		dB	Input 1.0V at 300Hz to 3400Hz at PG4	
11	Longitudinal Balance		52			dB	40 - 3400Hz 3400-4000Hz	
			41			dB		
12	Total Harmonic Distortion at TX at 2-Wire	THD		0.1	1.0	%	Input 1.0V at 1kHz at 2-Wire Input 1.0V at 1kHz at PG4	
				0.1	1.0	%		
13	Common Mode Reject Ratio	CMRR	40				CCITT 0.121	
14	Idle Channel Noise at TX (0dB gain) Idle Channel Noise at 2-Wire (0dB gain)	Nc Np Nc Np		13	18	dBrnC		
				-78	-73	dBrnp		
				11	16	dBrnC		
				-80	-75	dBrnp		
15	Power Supply Reject Ratio V <sub>DD</sub> V <sub>EE</sub> V <sub>BAT</sub>	PSRR	25			dB	Ripple 1Vpp 1kHz Measure 2-Wire or TX	
			20			dB		
			30			dB		
16	Dial Pulse Distortion (SHK High to Low Time)	t <sub>d</sub>		0.4	1	ms	2-Wire loop at 1.2kΩ	

<sup>†</sup> AC Electrical Characteristics are over recommended operating unless otherwise stated.

<sup>\*</sup> Typical figures are at 25 C and are for design aid only; not guaranteed and not subject to production testing.



**Table 1: Impedance Matching with Jumpers**

	Zin Code	Zin 2-Wire Input Impedance	Administration	ZN1 Link to:	ZN8 Link to:
1	600	600Ω	---	ZN7	---
2	UK	370Ω + 620Ω // 310nF	United Kingdom	ZN6	ZN13
3	D	220Ω + 820Ω // 310nF	Germany, Austria	ZN5	ZN12
4	NA	350Ω + 1000Ω // 310nF	Canada, USA	ZN4	ZN11
5	F	210Ω + 880Ω // 310nF	France	ZN3	ZN10
6	N	120Ω + 820Ω // 310nF	Norway	ZN2	ZN9
7	A	220Ω + 820Ω // 310nF	Australia	Use D Code	Use D Code

Note 1: The above impedances are as suggested by references: BS6305 (UK), REG3 (Australia), Proposed NET4, FCC Part 68 and recommendations by the various Administrations. Confirm your impedance requirements before proceeding.

Note 2: All links to ZN1 should be as short as possible.

**Table 2: Impedance Matching with External Components**

	Zin Code	Zin 2-Wire Input Impedance	Administration	Rs	Rp	Cp
1	---	600Ω + 2.16μF	---	6kΩ	1MΩ	216nF
2	ATT	900Ω + 2.16μF	AT&T	9kΩ	1MΩ	216nF
3	NTT	600Ω + 1.0μF	NTT	6kΩ	1MΩ	100nF
4	NZ	370Ω + (620Ω // 220nF)	New Zealand	3.7kΩ	6.2kΩ	22nF

Note 1: The above impedances are as suggested by reference CCITT Q.522. Confirm your impedance requirements before proceeding.

Note 2: For Rs, Rp & C calculations, G is set to 10, R is set to 5656.8Ω, refer to figure 8 for additional information.

**Table 3: Transmit and Receive Gain Programming**

Transmit Gain (dB)	RTX Resistor Value (Ω)	Notes
+5.62	270k	
+4.0	No Resistor	Results in 0dB overall gain when used with Mitel A-law codec (ie MT8965)
+3.69	216k	Results in 0dB overall gain when used with Mitel μ-law codec (ie MT8964)
+2.1	180k	
0.0	141k	
-3.0	100k	
Transmit Gain (dB)	RTX Resistor Value (Ω)	Notes
+6.6	33.1k	
+0.0	70.7k	
-3.0	100k	
-3.69	108k	Results in 0dB overall gain when used with Mitel A-law codec (ie. MT8964)
4.0	No Resistor	Results in 0dB overall gain when used with Mitel μ-law codec (ie MT8965)
-6.5	150k	

Note 1: See Figures 4 and 5 for additional details.

Note 2: Overall gain refers to the receive path of PCM to 2-Wire, and to transmit path of 2-Wire to PCM.

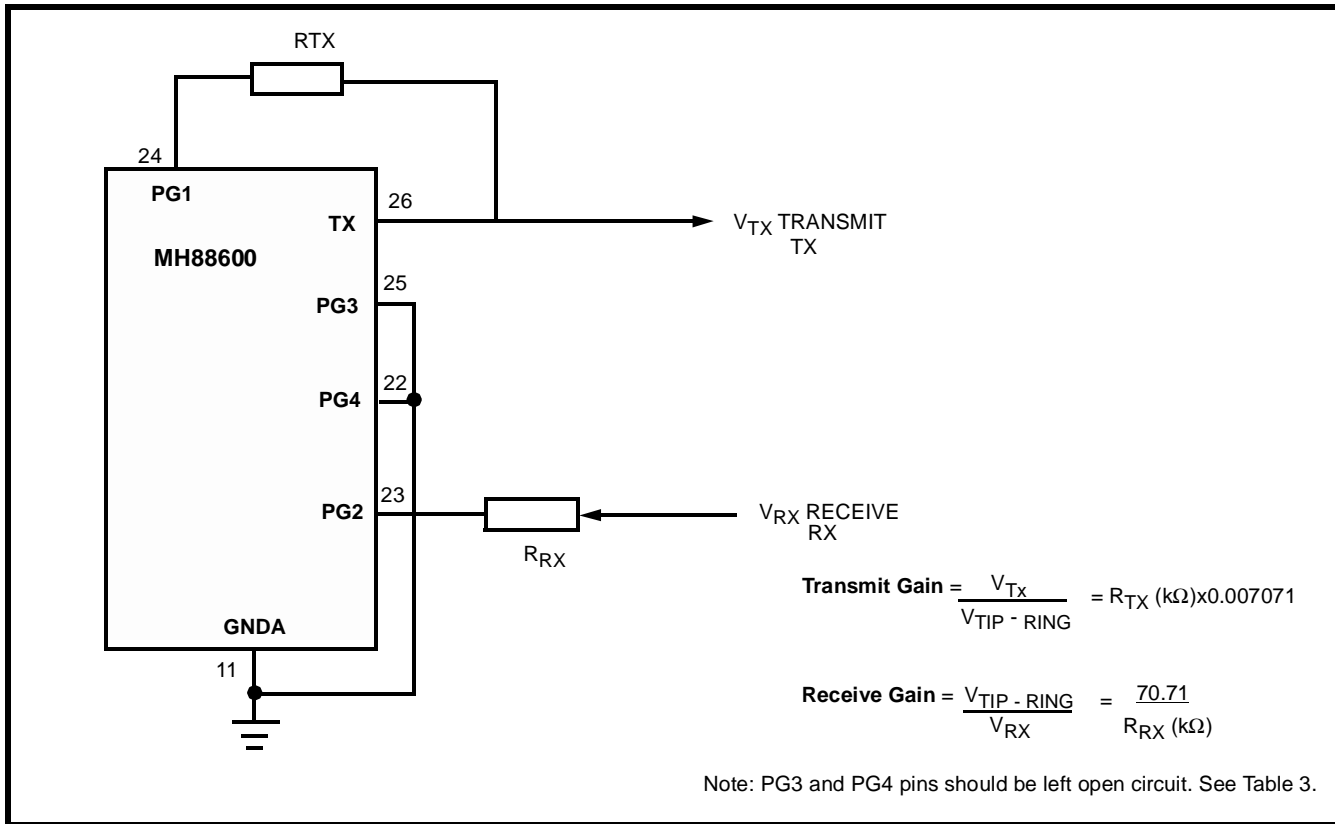

Figure 4 - Configuration of MH88600 for Gain Programming

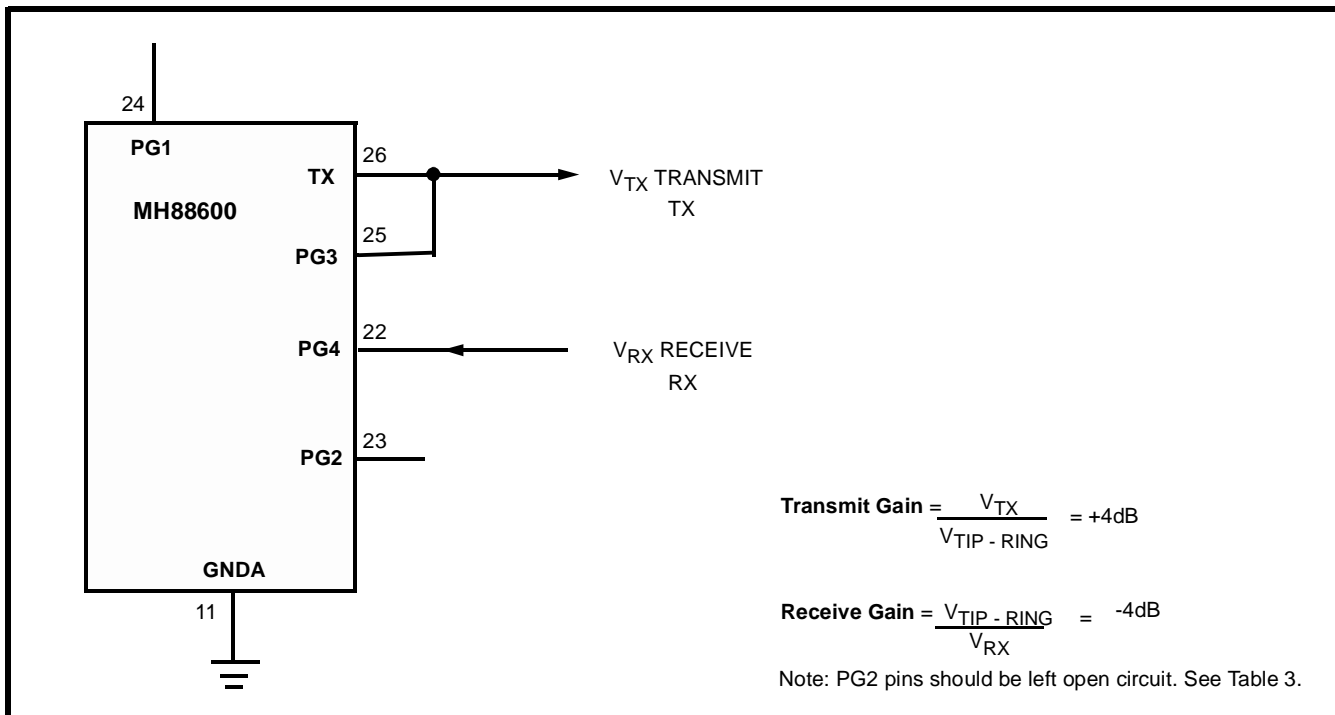

Figure 5 - Configuration of MH88600 for Default Gains

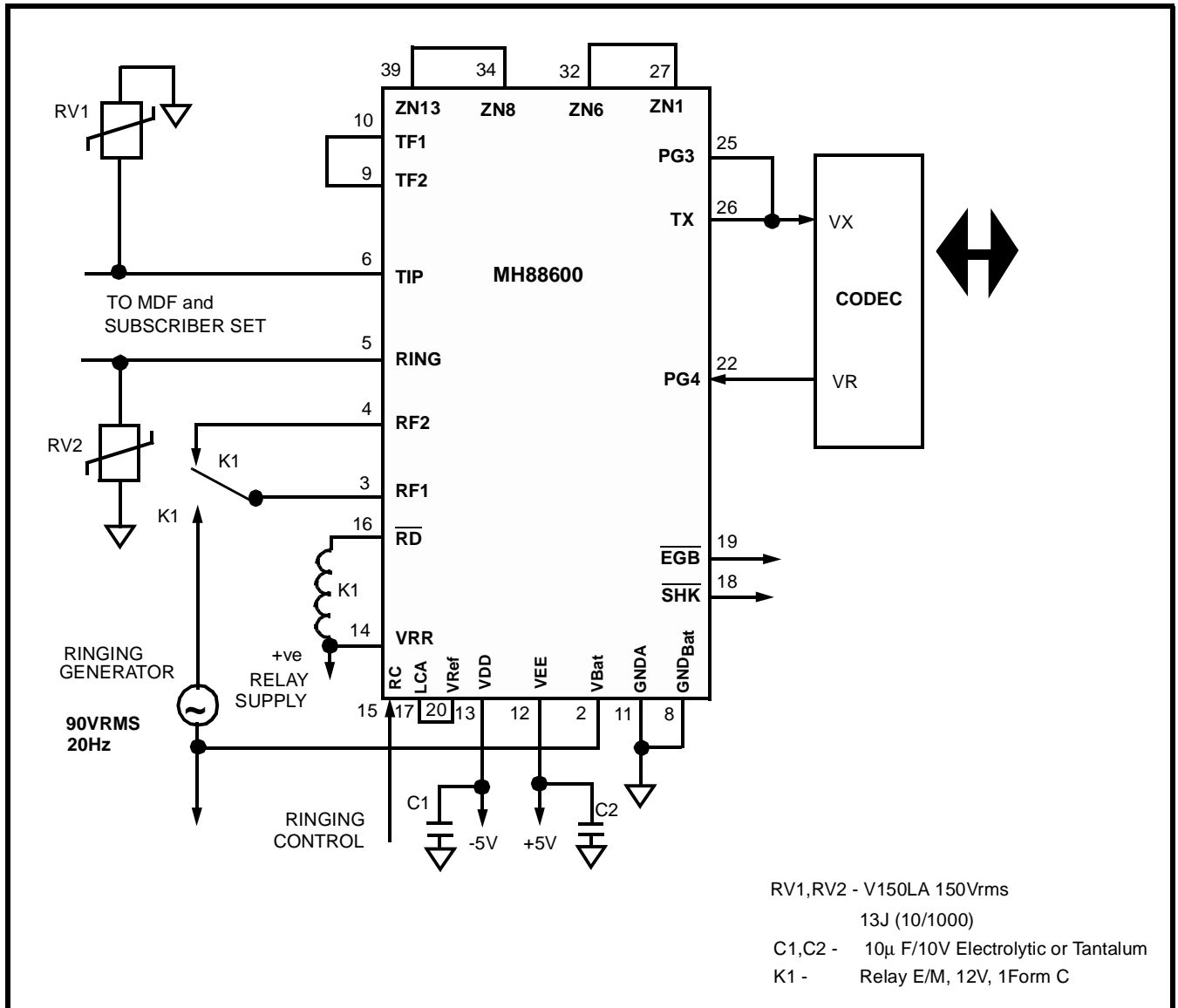

Figure 6- Typical Application Circuit

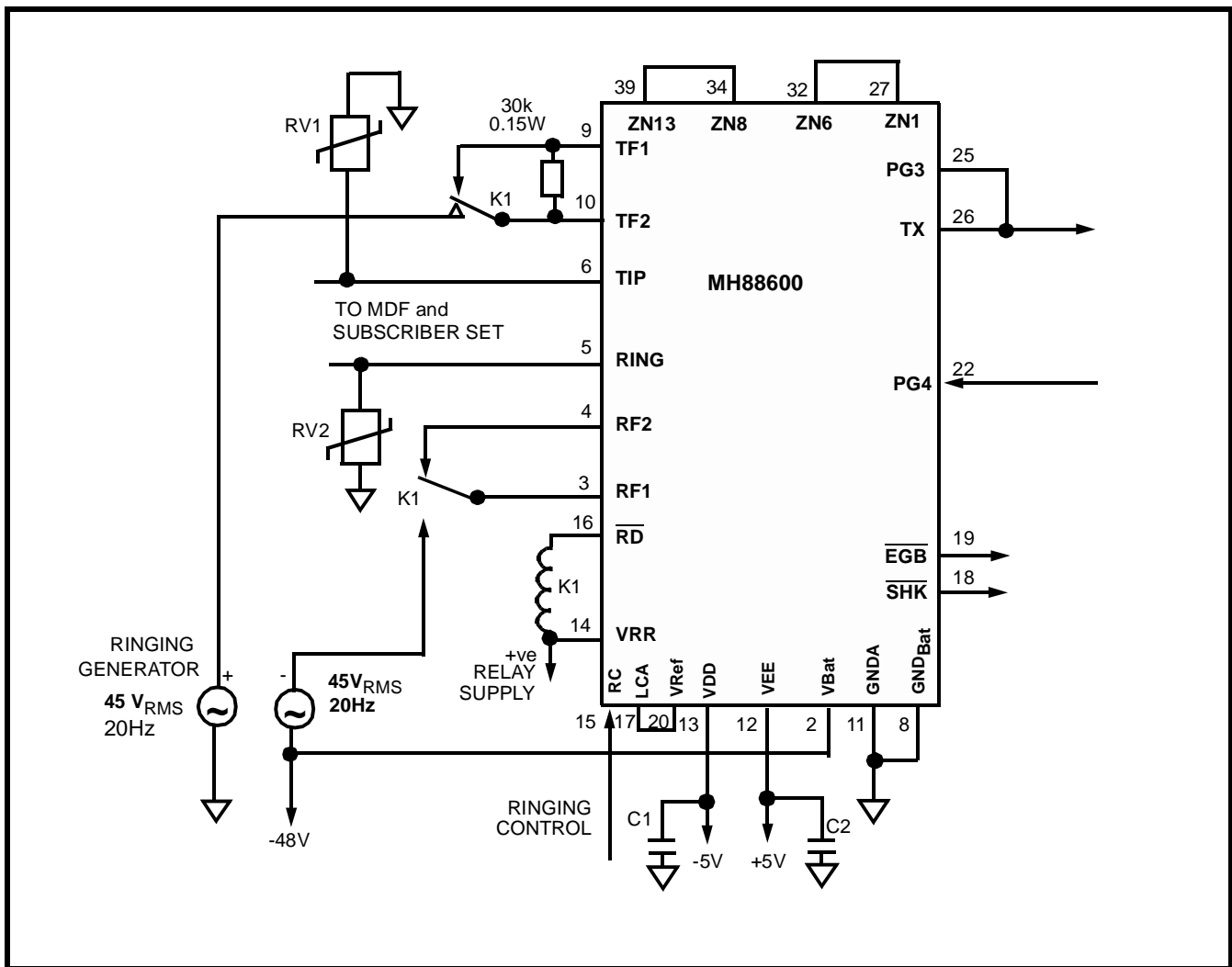

Figure 7 - Application Circuit for Balanced Ringing

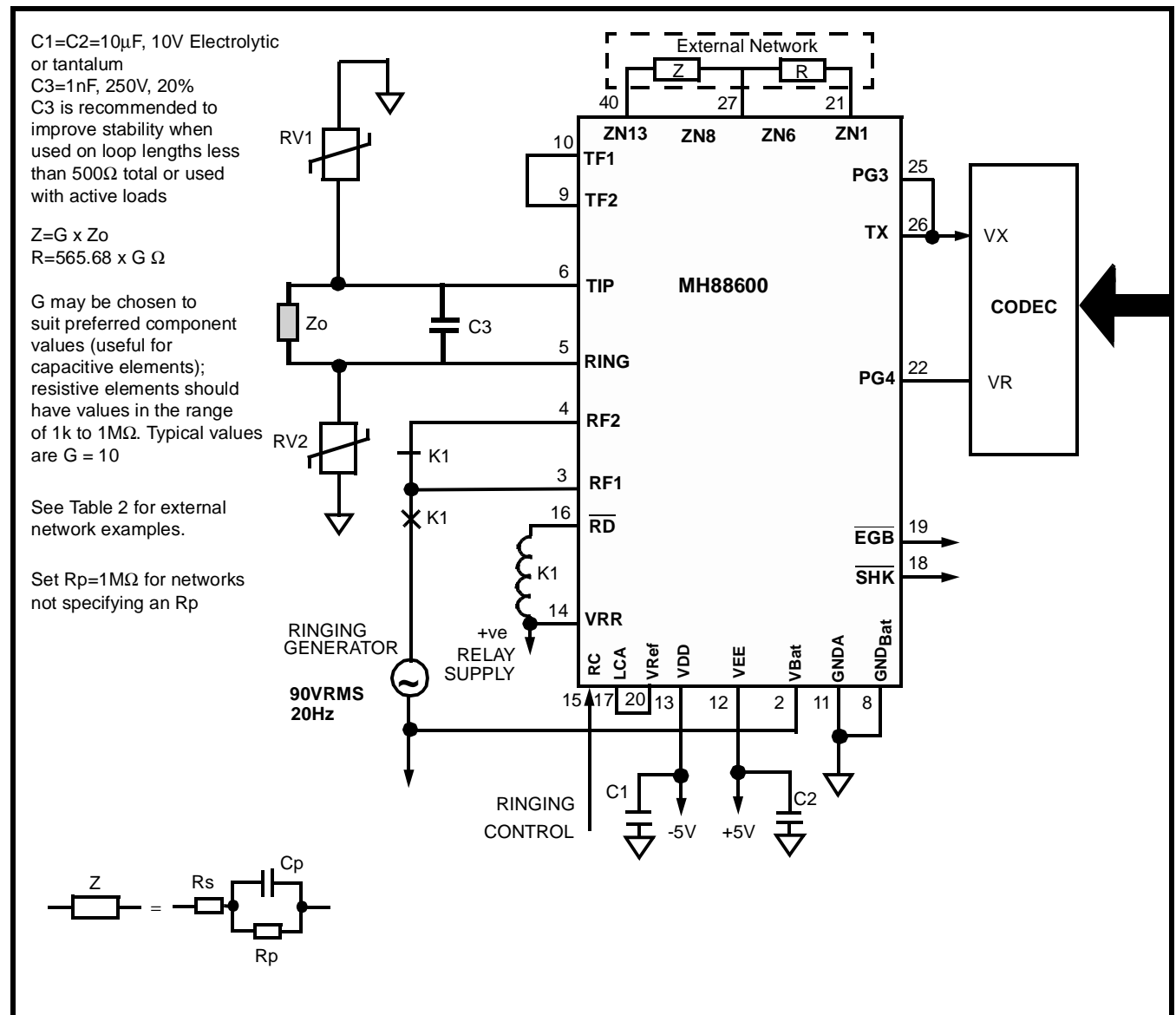

Figure 8 - Using an External Network to Match any  $Z_o$

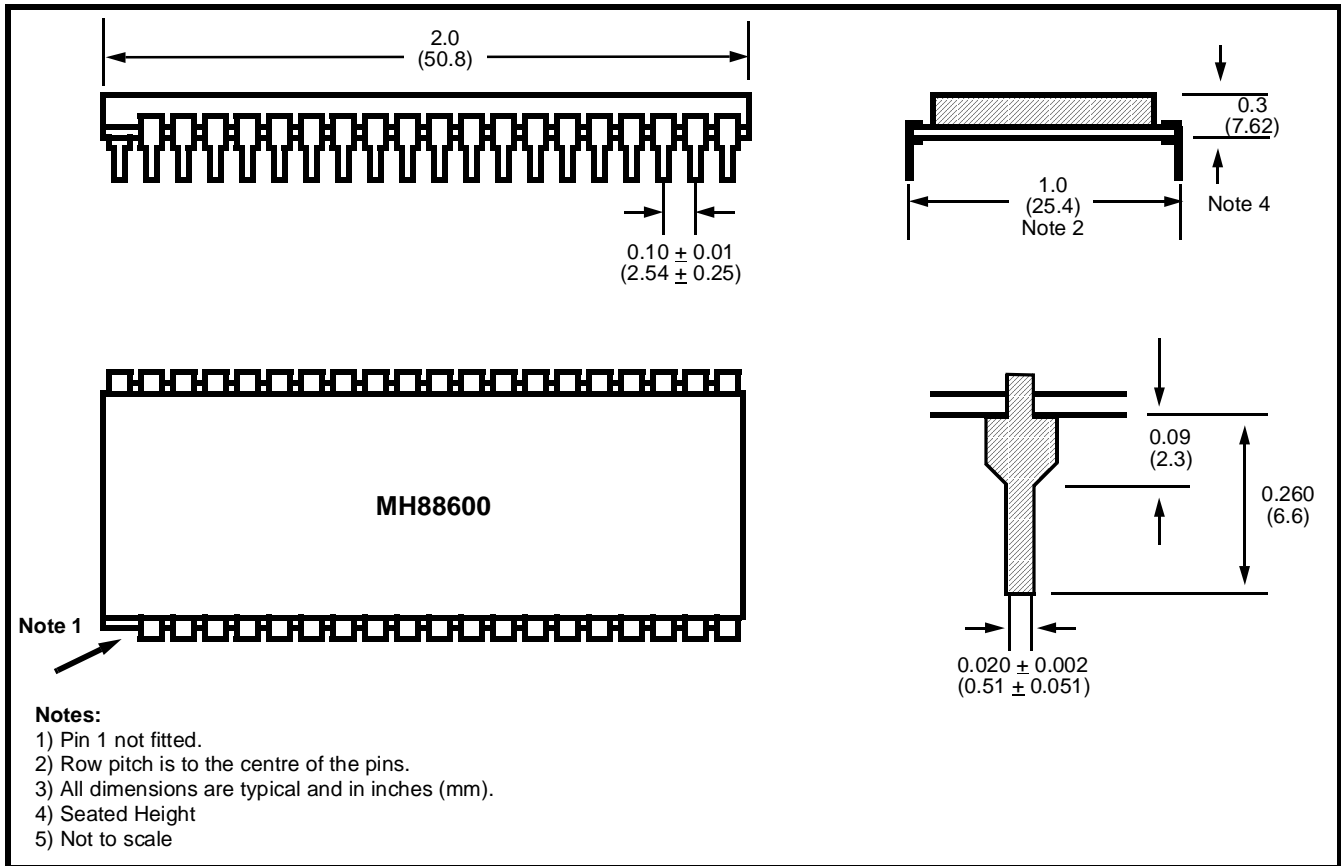

Figure 9 - Mechanical Data