

**LIQUID CRYSTAL DISPLAY MODULE**

**G 1 2 1 C 0 0 P 0 0 C**

**G 1 2 1 C B 1 P 0 0 C**

**USER'S MANUAL**

**Seiko Instruments Inc.**

## NOTICE

This manual provides technical information covering functions and operational instructions for the G121C liquid crystal display modules with a built-in LCD controller. Please read through this manual before operating the product. Distribution of this manual to third parties for any purpose other than operation of the product is prohibited. The descriptions herein are subject to change without prior notice. Application information is intended solely for general guidance. Use of the information contained herein for the user's application is done at the user's risk.

### Revision Record

| <u>Version</u> | <u>Revision</u> | <u>Date</u>    |
|----------------|-----------------|----------------|
| 1              | Original        | September 1994 |
| 2              |                 | June 1995      |

Copyright © 1994 by Seiko Instruments Inc.

Printed in Japan

**CONTENTS****· G121C00P00C, G121CB1P00C**

|   |    |
|---|----|
| <b>1. SPECIFICATIONS</b>  |    |
| 1.1 General .....   | 1  |
| 1.2 Features .....  | 1  |
| 1.3 Absolute Maximum Ratings (excluding LED backlight).....     | 2  |
| 1.4 Mechanical Characteristics .....                            | 2  |
| 1.5 Electrical Characteristics (excluding LED backlight) .....  | 3  |
| 1.6 Optical Characteristics .....                               | 4  |
| 1.7 LCD Panel Lifetime .....                                    | 6  |
| 1.8 Dimensions .....  | 7  |
| <b>2. CIRCUIT CONFIGURATION</b>                                 |    |
| 2.1 Block Diagram .....   | 8  |
| 2.2 LCD Controller (SEIKO EPSON SED 1335F) .....                | 9  |
| 2.3 Common Driver (HITACHI HD66205TF).....                      | 9  |
| 2.4 Segment Drivers (HITACHI HD66204TF) .....                   | 9  |
| 2.5 V <sub>opr</sub> Control Circuit .....                      | 10 |
| 2.6 Bias Voltage Generator .....                                | 11 |
| 2.7 M' Generator .....  | 11 |
| <b>3. OPERATING INSTRUCTIONS</b>                                |    |
| 3.1 Terminal Functions .....                                    | 12 |
| 3.2 Timing Characteristics .....                                | 14 |
| 3.3 Reset .....   | 16 |
| 3.4 Setting the Power Supply and the Signals to On or Off ..... | 16 |
| 3.5 Commands .....  | 17 |
| 3.6 Display Data RAM .....                                      | 18 |
| 3.7 Example of an Initial Setting .....                         | 18 |
| 3.8 Example of MPU Interface .....                              | 23 |

**· G121CB1P00C**

|   |    |
|---|----|
| <b>4. LED BACKLIGHT</b>                     |    |
| 4.1 Absolute Maximum Ratings.....           | 24 |
| 4.2 Electro-optical Characteristics .....   | 24 |
| 4.3 LED Backlight Diagram .....             | 24 |
| 4.4 Brightness (Top surface of LCD) .....   | 24 |
| 4.5 Lifetime .....                          | 25 |
| 4.6 Examples of LED Backlight Drivers ..... | 25 |

**· G121C00P00C, G121CB1P00C**

|                             |           |
|-----------------------------|-----------|
| <b>5. PRECAUTIONS</b> ..... | <b>27</b> |
|-----------------------------|-----------|

**INDEX**

## 1. SPECIFICATIONS

### 1.1 General

The G121C is a very thin LCD module which incorporates a full-dot matrix LCD panel and CMOS IC driver. G121C can be used within a wide temperature range. The built-in LCD controller (SED1335F) also interfaces easily with an MPU. This full-dot configuration allows a wide variety of patterns to be displayed depending upon the input data. There is no distortion or displacement in the display because the display position is the point on the matrix where the transparent electrodes intersect.

### 1.2 Features

#### G121C00P00C/G121CB1P00C:

- 128 × 128 full dot matrix configuration
- 1/128 duty, 1/10 bias
- Built-in LCD controller SED1335F
- Selectable interface between an 80 series MPU and a 68 series MPU
- 8KB internal display data RAM
- Built-in 160 character (5 × 7 dots) CGROM
- STN LCD with a wide operating temperature range and gray mode
- Positive display
  - Display data "H": Display ON: blue display color
  - Display data "L": Display OFF: gray background color

#### G121C00P00C:

- Dual power supplies:  $V_{DD} = +5\text{ V}$ ,  $V_{LC} = -24\text{ V}$  (LCD driving voltage)
- Reflective
- Weight: Approximately 64 g

#### G121CB1P00C:

- Triple power supplies:  $V_{DD} = +5\text{ V}$ ,  $V_{LC} = -24\text{ V}$  (LCD driving voltage), LEDA (LED anode)
- Transflective
- Built-in LED backlight (color: yellow-green)
- Weight: Approximately 81 g

## 1.3 Absolute Maximum Ratings (excluding LED backlight)

V<sub>SS</sub> = 0 V

| Item                  | Symbol           | Conditions                       | Min.                   | Max.                  | Unit |
|-----------------------|------------------|----------------------------------|------------------------|-----------------------|------|
| Power supply voltage  | V <sub>DD</sub>  |                                  | - 0.3                  | 7.0                   | V    |
|                       | V <sub>LC</sub>  |                                  | V <sub>DD</sub> - 30.0 | V <sub>DD</sub>       | V    |
|                       | V <sub>O</sub>   | V <sub>O</sub> ≧ V <sub>LC</sub> | V <sub>DD</sub> - 30.0 | V <sub>DD</sub>       | V    |
| Input voltage         | V <sub>IN</sub>  |                                  | - 0.3                  | V <sub>DD</sub> + 0.3 | V    |
| Operating temperature | T <sub>opr</sub> | ≧ 65% RH                         | - 20                   | + 70                  | °C   |
| Storage temperature   | T <sub>stg</sub> |                                  | - 30                   | + 80                  | °C   |
| Storage humidity      |                  | ≧ 48 hrs                         | 20                     | 85                    | % RH |
|                       |                  | ≧ 1000 hrs                       | 20                     | 65                    | % RH |

## 1.4 Mechanical Characteristics

| Item                                 | Standard  |
|--------------------------------------|---|
| Dot configuration                    | 128 × 128 dot   |
| Module dimensions (H × V × T) [ mm ] | G121C00P00C: 86.0 × 95.0 × 8.0 max<br>G121CB1P00C: 86.0 × 95.0 × 10.0 max |
| Viewing area (H × V) [ mm ]          | 67.4 × 67.4   |
| Active display area (H × V) [ mm ]   | 62.69 × 62.69   |
| Dot dimensions (H × V) [ mm ]        | 0.46 × 0.46   |
| Dot pitch (H × V) [ mm ]             | 0.49 × 0.49   |
| Weight [ g ]                         | G121C00P00C: 75 max<br>G121CB1P00C: 100 max                               |

H : Horizontal    V : Vertical    T : Thickness (max.)

## 1.5 Electrical Characteristics (excluding LED backlight)

 $V_{DD} = 5V \pm 5\%$ ,  $V_{SS} = 0V$ ,  $T_a = -20^\circ\text{C}$  to  $+70^\circ\text{C}$ 

| Item                                 | Symbol    | Conditions                                   | Min.        | Typ.        | Max.        | Unit |
|--------------------------------------|-----------|--|-------------|-------------|-------------|------|
| Power supply voltage                 | $V_{DD}$  |  | 4.75        | 5.00        | 5.25        | V    |
|                                      | $V_{LC}$  | $V_{DD} = 5V$                                | -24.5       | -24.0       | -23.5       | V    |
|                                      | $V_O$     | $V_O \cong V_{LC}$                           | -23.0       | -           | -5.0        | V    |
| Input voltage <sup>1</sup><br>(CMOS) | High      | $V_{IHC}$                                    | $0.8V_{DD}$ | -           | $V_{DD}$    | V    |
|                                      | Low       | $V_{ILC}$                                    | 0           | -           | $0.2V_{DD}$ | V    |
| Input voltage <sup>2</sup><br>(TTL)  | High      | $V_{IHT}$                                    | $0.5V_{DD}$ | -           | $V_{DD}$    | V    |
|                                      | Low       | $V_{ILT}$                                    | 0           | -           | $0.2V_{DD}$ | V    |
| Input voltage <sup>3</sup><br>(RES)  | High      | $V_{T+}$                                     | $0.5V_{DD}$ | $0.7V_{DD}$ | $0.8V_{DD}$ | V    |
|                                      | Low       | $V_{T-}$                                     | $0.2V_{DD}$ | $0.3V_{DD}$ | $0.5V_{DD}$ | V    |
| Output voltage <sup>4</sup>          | High      | $V_{OH}$                                     | 2.4         | -           | -           | V    |
|                                      | Low       | $V_{OL}$                                     | -           | -           | 0.4         | V    |
| Current consumption <sup>5</sup>     | $I_{DD}$  | $V_{DD} = 5V, T_a = 25^\circ\text{C}$        | -           | 10.0        | 15.0        | mA   |
|                                      | $I_{LC}$  | $V_O = -15.0V$<br>$f_{FLM} = 71.4\text{ Hz}$ | -           | 4.1         | 6.2         | mA   |
| Frame frequency                      | $f_{FLM}$ |  | -           | 71.4        | -           | Hz   |

1 Applied to SEL1 and SEL2.

2 Applies to  $\overline{INH}$ ,  $A_0$ ,  $\overline{CS}$ ,  $\overline{RD}$ ,  $\overline{WR}$ , and  $D_0$  to  $D_7$ .

3 Applied to RES.

4 Applied to  $D_0$  to  $D_7$ .5 Display patterns: Checkered patterns, Display data shift clock frequency:  $f_{CL2} = 6.0\text{ MHz}$

## 1.6 Optical Characteristics

## 1.6.1 G121C00P00C

1/128 duty, 1/10 bias,  $f_{FLM} = 71.4 \text{ Hz}$ ,  $V_{opr} = V_{DD} - V_O$ 

| Item          | Sym.                  | Conditions  | Temp. | Min. | Typ. | Max. | Unit   | Remark                 |
|---------------|-----------------------|---|-------|------|------|------|--------|------------------------|
| Viewing angle | $\theta_1$            | $C \geq 2.0$  | 25°C  | -    | -    | -5   | Degree | Refer to Notes 1 and 2 |
|               | $\theta_2$            | $\varnothing = 0^\circ$   |       | 50   | -    | -    |        |                        |
|               | $\theta_2 - \theta_1$ | $V_{opr} = 20.0 \text{ V}$  |       | 55   | -    | -    |        |                        |
| Contrast      | C                     | $\theta = 0^\circ$<br>$\varnothing = 0^\circ$<br>$V_{opr} = 20.0 \text{ V}$ | 25°C  | 2.5  | 3.5  | -    | -      | Note 3                 |
| Response time | $t_{on}$              | $\theta = 0^\circ$<br>$\varnothing = 0^\circ$<br>$V_{opr} = 20.0 \text{ V}$ | 25°C  | -    | 150  | 240  | ms     | Note 4                 |
|               | $t_{off}$             |   |       | -    | 110  | 180  |        |                        |
|               | $t_{on}$              | $\theta = 0^\circ$<br>$\varnothing = 0^\circ$<br>$V_{opr} = 21.5 \text{ V}$ | -10°C | -    | 1060 | 1700 |        |                        |
|               | $t_{off}$             |   |       | -    | 500  | 800  |        |                        |
|               | $t_{on}$              | $\theta = 0^\circ$<br>$\varnothing = 0^\circ$<br>$V_{opr} = 22.0 \text{ V}$ | -20°C | -    | 2860 | 4600 |        |                        |
|               | $t_{off}$             |   |       | -    | 780  | 1300 |        |                        |

Measuring instrument : Canon illuminometer LC-3S

## 1.6.2 G121CB1P00C

1/128 duty, 1/10 bias,  $f_{FLM} = 71.4 \text{ Hz}$ ,  $V_{opr} = V_{DD} - V_O$ , LED backlight : ON

| Item          | Sym.                  | Conditions  | Temp. | Min. | Typ. | Max. | Unit   | Remark                 |
|---------------|-----------------------|---|-------|------|------|------|--------|------------------------|
| Viewing angle | $\theta_1$            | $C \geq 1.4$  | 25°C  | -    | -    | -20  | Degree | Refer to Notes 1 and 2 |
|               | $\theta_2$            | $\varnothing = 0^\circ$   |       | 30   | -    | -    |        |                        |
|               | $\theta_2 - \theta_1$ | $V_{opr} = 20.0 \text{ V}$  |       | 50   | -    | -    |        |                        |
| Contrast      | C                     | $\theta = 0^\circ$<br>$\varnothing = 0^\circ$<br>$V_{opr} = 20.0 \text{ V}$ | 25°C  | 2.0  | 2.4  | -    | -      | Note 3                 |
| Response time | $t_{on}$              | $\theta = 0^\circ$<br>$\varnothing = 0^\circ$<br>$V_{opr} = 20.0 \text{ V}$ | 25°C  | -    | 150  | 240  | ms     | Note 4                 |
|               | $t_{off}$             |   |       | -    | 110  | 180  |        |                        |
|               | $t_{on}$              | $\theta = 0^\circ$<br>$\varnothing = 0^\circ$<br>$V_{opr} = 21.5 \text{ V}$ | -10°C | -    | 1060 | 1700 |        |                        |
|               | $t_{off}$             |   |       | -    | 500  | 800  |        |                        |
|               | $t_{on}$              | $\theta = 0^\circ$<br>$\varnothing = 0^\circ$<br>$V_{opr} = 22.0 \text{ V}$ | -20°C | -    | 2860 | 4600 |        |                        |
|               | $t_{off}$             |   |       | -    | 780  | 1300 |        |                        |

Measuring instrument : Canon illuminometer LC-3S

Note 1: Definition of angle  $\theta$  and  $\varnothing$

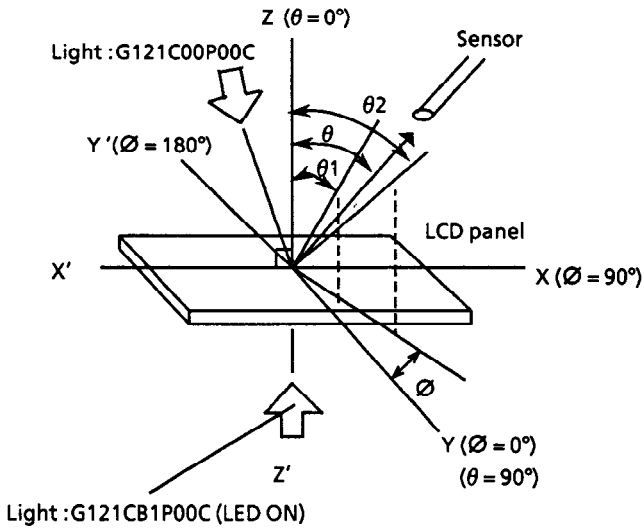

Note 2: Definition of viewing angles  $\theta_1$  and  $\theta_2$

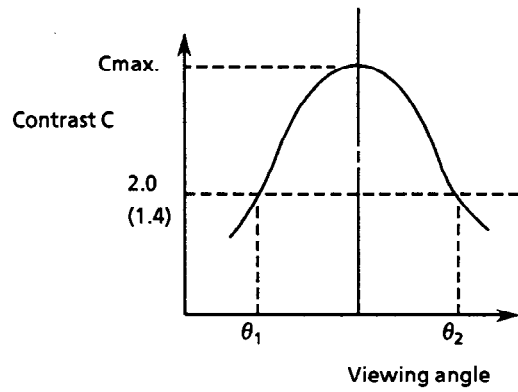

Remark : The optimum viewing angle by visual inspection and angle  $\theta$  at Cmax do not always match.

Note 3: Definition of contrast (C)

$$C = \frac{\text{Brightness of non-selected dot } B_2}{\text{Brightness of selected dot } B_1}$$

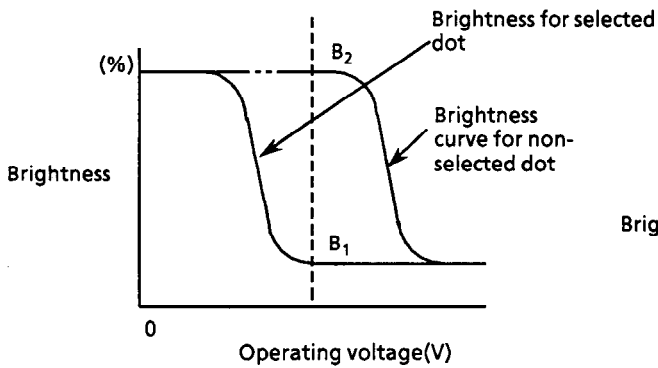

Note 4: Definition of response time

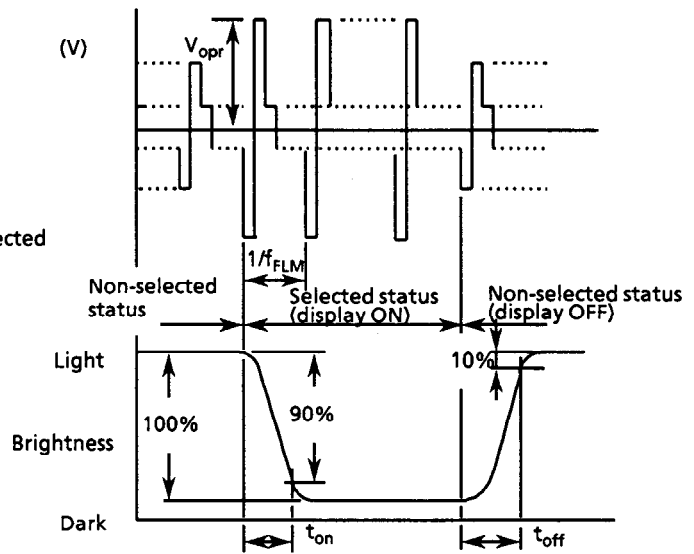

$V_{opr}$  : Operating voltage       $t_{on}$  : Response time (rise)  
 $f_{FLM}$  : Frame frequency       $t_{off}$  : Response time (fall)

Note: The measurements must be made using a G121C transmissive LCD panel.

Figure 1 Definition



## 1.7 LCD Panel Lifetime

| Item                  | Conditions                | Standard        | Unit |
|-----------------------|---------------------------|-----------------|------|
| Lifetime <sup>1</sup> | 25 °C ± 10 °C<br>< 65% RH | 100,000 or more | hrs  |

<sup>1</sup> Definition of lifetime: the time up to occurrence of any of the following:

- Contrast reduces to 30% of the initial value.
- Current consumption becomes three times the initial value.
- Orientation deteriorates significantly.
- The display malfunctions.

## 1.8 Dimensions

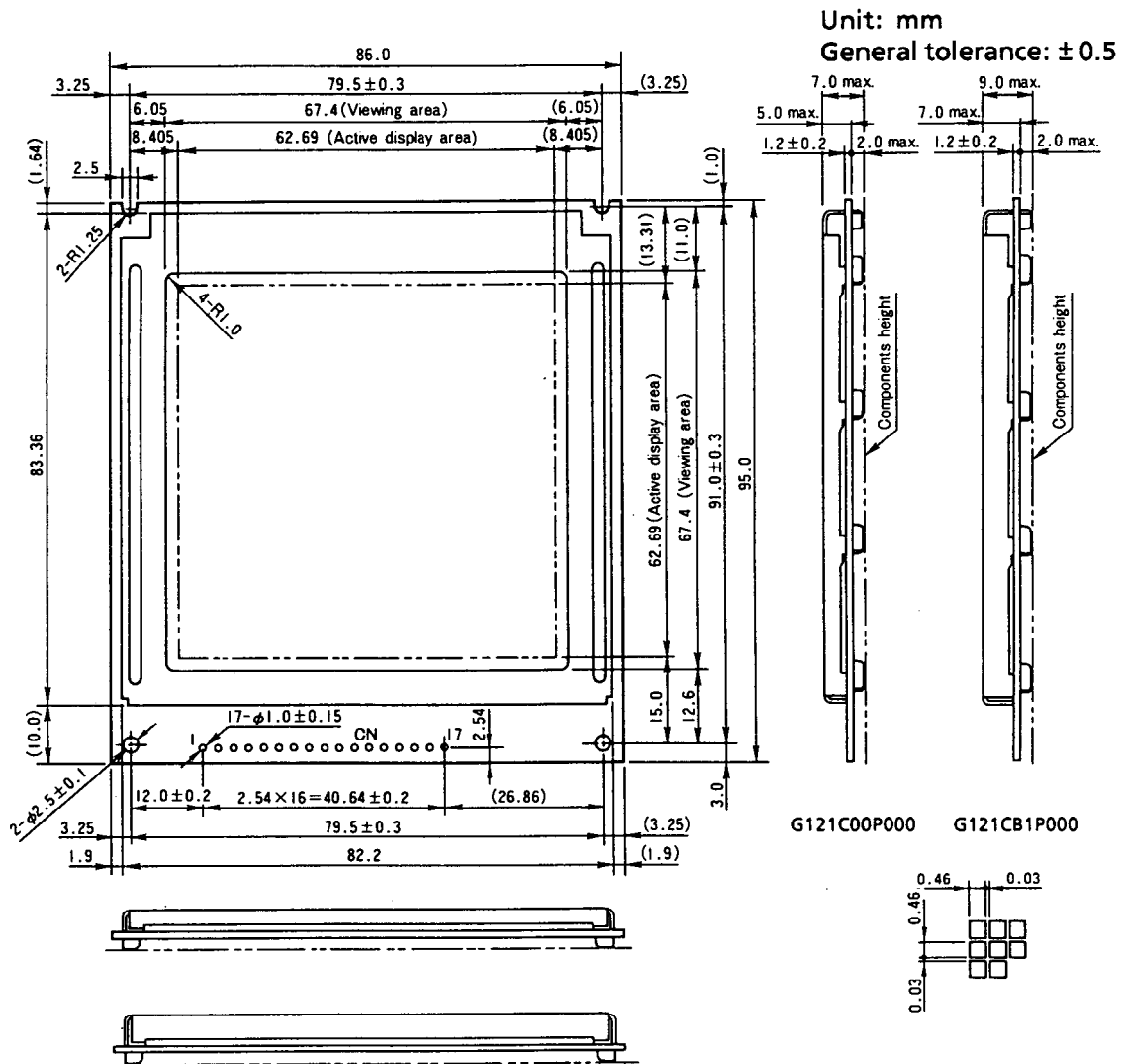

Figure 2 Dimensions

## I/O terminal functions

| No | Sym.                    | Functions  | No | Sym.             | Functions   |
|----|-------------------------|--|----|------------------|---|
| 1  | $\overline{\text{RES}}$ | Reset signal input   | 11 | D3               | Data bus line   |
| 2  | $\overline{\text{RD}}$  | 80 series MPU...Read signal<br>68 series MPU...“E” clock   | 12 | D4               | Data bus line   |
| 3  | $\overline{\text{WR}}$  | 80 series MPU...Write signal<br>68 series MPU...R/W signal | 13 | D5               | Data bus line   |
| 4  | SEL2                    | 80/68 series MPU bus switching terminal                    | 14 | D6               | Data bus line   |
| 5  | SEL1                    | 80/68 series MPU bus switching terminal                    | 15 | D7               | Data bus line   |
| 6  | $\overline{\text{CS}}$  | Chip select input  | 16 | V <sub>DD</sub>  | Power supply for logic circuit (+ 5 V)                            |
| 7  | A0                      | Identifying signal for data bus signal                     | 17 | V <sub>SS</sub>  | GND (0 V)   |
| 8  | D0                      | Data bus line  | 18 | V <sub>O</sub>   | Adjustment terminal for liquid crystal driving voltage            |
| 9  | D1                      | Data bus line  | 19 | V <sub>LC</sub>  | Power supply terminal for driving liquid crystal display (- 24 V) |
| 10 | D2                      | Data bus line  | 20 | INH <sup>1</sup> | Display on/off control terminal                                   |
|    |                         |  | 21 | NC/LEDA          | <sup>-2</sup>   |
|    |                         |  | 22 | NC/LEDC          | <sup>-2</sup>   |

<sup>1</sup> After powering on, DC voltage is not applied to LCD by setting INH = “L” until the initialization of LCD controller is completed. After DISP ON command is executed, the display is set to on by setting INH = “H” and set to off by setting INH = “L.”

<sup>2</sup> G121C00P00C : NC

G121CB1P00C : Power supply for LED backlight (No.21 : LEDA, No.22 : LEDC)

2. CIRCUIT CONFIGURATION

2.1 Block Diagram

G121C\*\*P\*\*C consists of an LCD controller, display data RAM, common drivers, segment drivers, a  $V_{opr}$  control circuit, a bias voltage generator,  $M'$  generator and so forth. Figure 3 shows the block diagram.

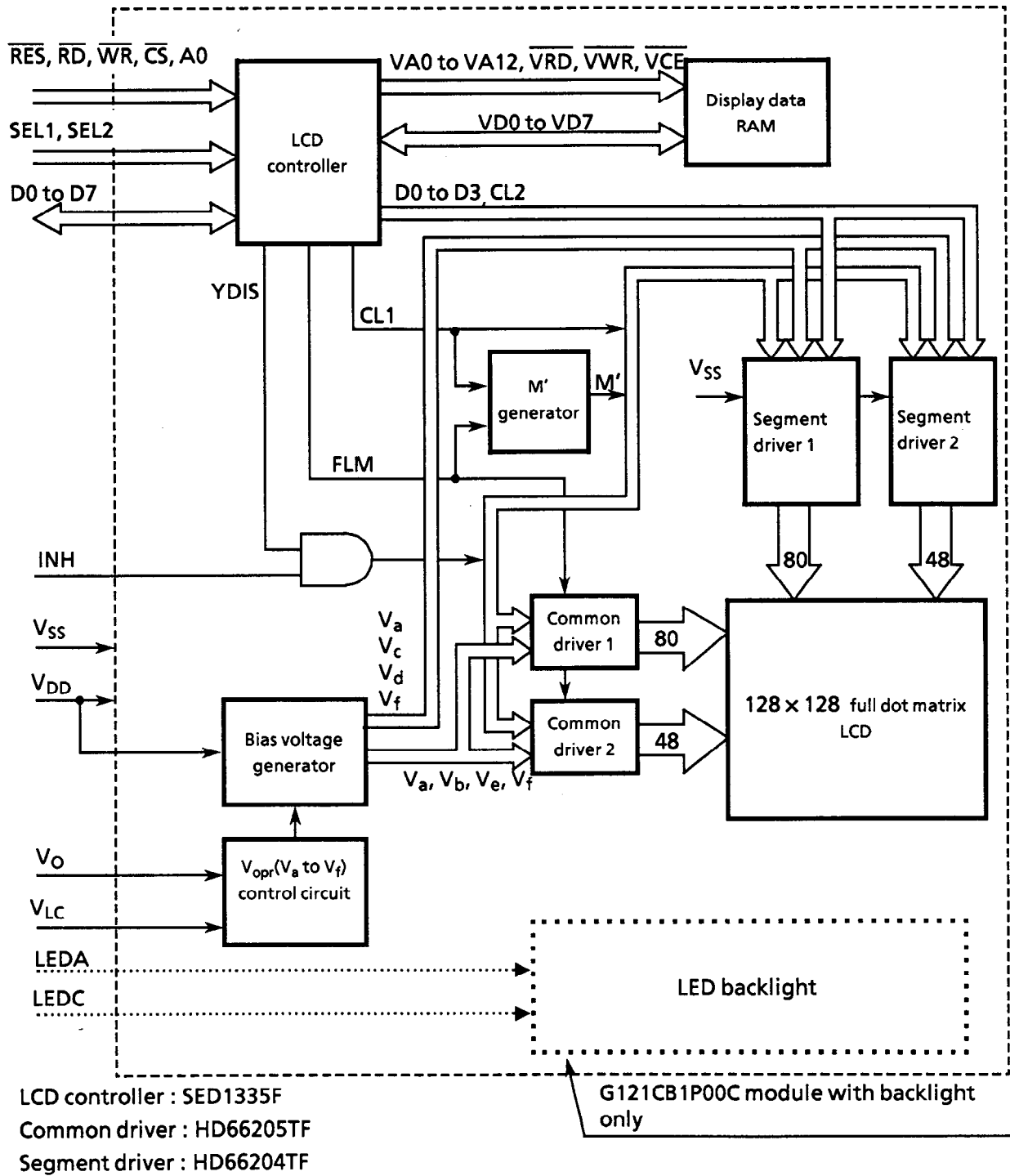

Figure 3 Block Diagram

## 2.2 LCD Controller (SEIKO EPSON SED1335F)

The LCD controller (SED1335F) is located between the MPU and the LCD panel. The LCD controller stores the character codes and the bit-mapped graphics data from the MPU in the display data RAM (8KB), and then periodically reads out the stored data, converts it, and sends the converted signal to the LCD module. Also, through many command functions, it is possible to overlap the character screen with the graphics screen and scroll the screen in all directions.

## 2.3 Common Driver (HITACHI HD66205TF)

The common driver (CD) is an 80 drive output CMOS IC. Two CDs are used in conjunction with each other in the G121C and operate as follows:

The CDs read the input one-frame timing signal (FLM) into the internal register at the one-common line timing signal (CL1) fall edge trigger and shift it sequentially. The common drive waveform is formed by the contents of this shift register and the signal to make the liquid crystal drive waveform AC ( $M'$ ). There are six voltage levels ( $V_a$  to  $V_f$ ) in the waveform. Table 1 shows the description of each level. Note that FLM signal and CL1 signal are input from LCD controller. After CL1 is input 128 times, the next FLM is input and the same operation is repeated.

Table 1 Description of each voltage level

|       |                                 |
|-------|---------------------------------|
| $V_a$ | Common, segment selection level |
| $V_b$ | Common non-selection level      |
| $V_c$ | Segment non-selection level     |
| $V_d$ | Segment non-selection level     |
| $V_e$ | Common non-selection level      |
| $V_f$ | Common, segment selection level |

INH signal and YDIS signal from the LCD controller control COM output. When INH signal or YDIS signal is set to "L",  $V_a$  is output to COM output regardless of the contents of the shift register and  $M'$  signal.

## 2.4 Segment Driver (HITACHI HD66204TF)

The segment driver is an 80 drive output CMOS IC. Two segment drivers are used in the G121C and operate as follows:

4 bit input display data is read sequentially into the internal register at the display data shift clock (CL2) fall edge trigger. This display data and CL2 signal are input from the LCD controller. Because a chip enable function is built into the segment driver, when the 80 bit display data is input to SD1, the next data is automatically sent to segment driver 2. The two segment drivers read 128 bit display data. Thus the input display data in the internal register is latched at the one-common line

timing signal (CL1) fall edge trigger. The segment drive waveform is formed by the display data and the signal to make the liquid crystal drive waveform AC ( $M'$ ).

The INH signal and the YDIS signal from the LCD controller control SEG output. When the INH signal or the YDIS signal is set to "L,"  $V_a$  is output to SEG output regardless of the contents of the shift register and  $M'$  signal. Consequently, when the INH at the input terminal or the YDIS signal from the LCD controller is set to "L,"  $V_a$  is applied to COM output and SEG output, 0 V is applied to the liquid crystal and the display is set to off.

## 2.5 $V_{opr}$ Control Circuit

The viewing angle of the LCD panel and the shade of the screen depends on the liquid crystal operating voltage ( $V_{opr}$ ). With the G121C,  $V_{LC}$  is applied from outside. This  $V_{LC}$ , as shown in Figure 4, is supplied with an operational amplifier and the voltage  $V_{opr}$  ( $V_a$  to  $V_f$ ) applied to the LCD panel is generated.

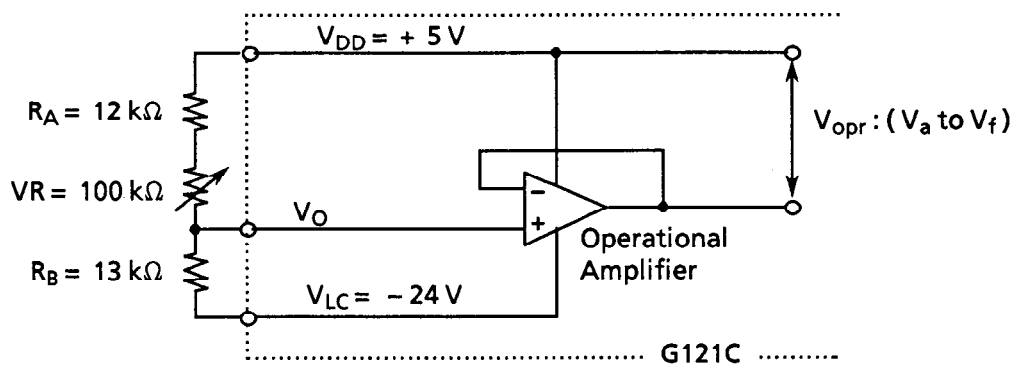

Figure 4  $V_{opr}$  Control Circuit

Also, the viewing angle of the LCD panel and the shade of the screen depend on the ambient temperature. The recommended values of the  $V_{opr}$  for the ambient temperature are as follows:

Table 2 LC operating voltage

| Temperature (°C)           | -20  | 0    | 25   | 50   | 70   |
|----------------------------|------|------|------|------|------|
| Voltage ( $V_{opr}$ )* (V) | 22.0 | 21.5 | 20.0 | 19.0 | 18.0 |

\*  $V_{opr} \approx V_{DD} - V_O$

2.6 Bias Voltage Generator

Six levels of voltage  $V_a$  to  $V_f$  are applied to the drivers as a bias voltage. This voltage is generated from  $V_{opr}$  by dividing the resistance and driven by a voltage follower through an operational amplifier.

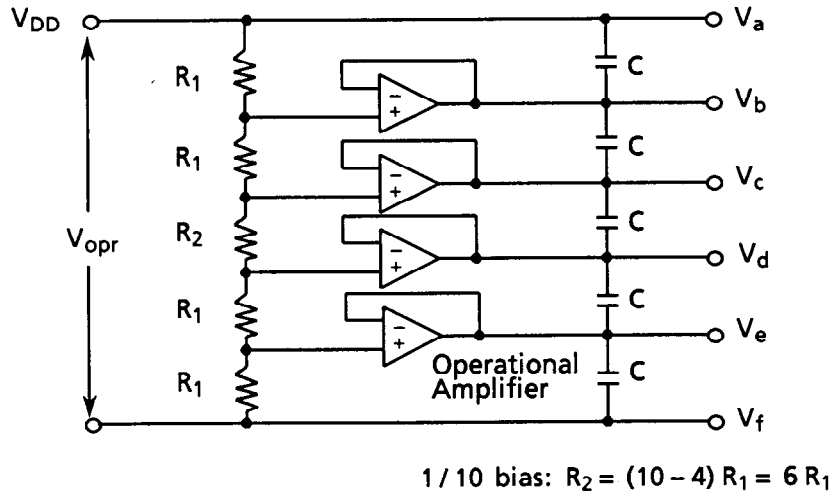

Figure 5 Bias Voltage Generator

2.7 M' Generator

M' generator outputs the Ex-ORed signal between the divided signal of the one-common line timing signal (CL1) to A and the divided signal of the one-frame timing signal (FLM) to B as 'M', which makes up the LC drive waveform AC. The values of A and B are set according to the LC panel to allow for the best quality display and to allow the drive voltage to be converted to AC.

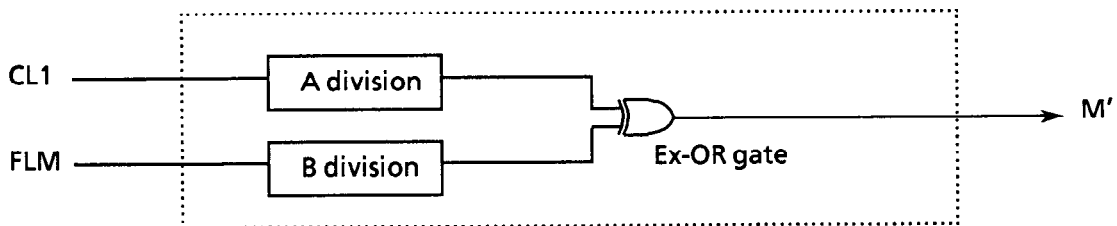

Figure 6 M' generator

### 3 OPERATING INSTRUCTIONS

#### 3.1 Terminal Functions

Table 3 Terminal Functions 1

| Signal                  | Q'ty   | I/O            | Functions   |                        |                         |                        |    |                        |                        |                        |   |   |           |    |                        |                        |                        |   |   |           |    |   |                         |                        |   |   |   |   |   |   |   |   |   |   |   |   |   |   |
|-------------------------|--------|----------------|---|------------------------|-------------------------|------------------------|----|------------------------|------------------------|------------------------|---|---|-----------|----|------------------------|------------------------|------------------------|---|---|-----------|----|---|-------------------------|------------------------|---|---|---|---|---|---|---|---|---|---|---|---|---|---|
| $\overline{\text{RES}}$ | 1      | Input          | Active "L"<br>Executes initial reset to the LCD controller by hardware.   |                        |                         |                        |    |                        |                        |                        |   |   |           |    |                        |                        |                        |   |   |           |    |   |                         |                        |   |   |   |   |   |   |   |   |   |   |   |   |   |   |
| $\overline{\text{RD}}$  | 1      | Input          | <ul style="list-style-type: none"> <li>80 series MPU<br/>Active "L"<br/>Strobe signal when MPU reads out the data or the status flag from the LCD controller. The data bus of LCD controller is set to the output status during "L".</li> <li>68 series MPU<br/>Active "H"<br/>Enable clock input terminal of 68 series MPU.</li> </ul>   |                        |                         |                        |    |                        |                        |                        |   |   |           |    |                        |                        |                        |   |   |           |    |   |                         |                        |   |   |   |   |   |   |   |   |   |   |   |   |   |   |
| $\overline{\text{WR}}$  | 1      | Input          | <ul style="list-style-type: none"> <li>80 series MPU<br/>Active "L"<br/>Strobe signal when 80 series MPU writes the data or the parameters into LCD controller. LCD controller fetches the data bus signal at the <math>\overline{\text{WR}}</math> rise edge.</li> <li>68 series MPU<br/>R/W control signal input terminal of 68 series MPU.<br/>R/W = "H" : READ<br/>R/W = "L" : WRITE</li> </ul>   |                        |                         |                        |    |                        |                        |                        |   |   |           |    |                        |                        |                        |   |   |           |    |   |                         |                        |   |   |   |   |   |   |   |   |   |   |   |   |   |   |
| SEL1<br>SEL2            | 1<br>1 | Input<br>Input | <p>MPU interface can be switched by the combination of SEL1 and SEL2, and can be connected directly to both 80 series MPU (Z80, 8085, etc.) data bus and 68 series MPU (6809, 6802) data bus.</p> <table border="1"> <thead> <tr> <th>SEL1</th> <th>SEL2</th> <th>Interface</th> <th>A0</th> <th><math>\overline{\text{RD}}</math></th> <th><math>\overline{\text{WR}}</math></th> <th><math>\overline{\text{CS}}</math></th> </tr> </thead> <tbody> <tr> <td>0</td> <td>0</td> <td>80 series</td> <td>A0</td> <td><math>\overline{\text{RD}}</math></td> <td><math>\overline{\text{WR}}</math></td> <td><math>\overline{\text{CS}}</math></td> </tr> <tr> <td>1</td> <td>0</td> <td>68 series</td> <td>A0</td> <td>E</td> <td><math>\overline{\text{R/W}}</math></td> <td><math>\overline{\text{CS}}</math></td> </tr> <tr> <td>0</td> <td>1</td> <td>*</td> <td>*</td> <td>*</td> <td>*</td> <td>*</td> </tr> <tr> <td>1</td> <td>1</td> <td>*</td> <td>*</td> <td>*</td> <td>*</td> <td>*</td> </tr> </tbody> </table> <p>* : Prohibited<br/>Normally SEL1 and SEL2 are directly connected to either power supply <math>V_{DD}</math> or <math>V_{SS}</math> to prevent noise.</p> | SEL1                   | SEL2                    | Interface              | A0 | $\overline{\text{RD}}$ | $\overline{\text{WR}}$ | $\overline{\text{CS}}$ | 0 | 0 | 80 series | A0 | $\overline{\text{RD}}$ | $\overline{\text{WR}}$ | $\overline{\text{CS}}$ | 1 | 0 | 68 series | A0 | E | $\overline{\text{R/W}}$ | $\overline{\text{CS}}$ | 0 | 1 | * | * | * | * | * | 1 | 1 | * | * | * | * | * |
| SEL1                    | SEL2   | Interface      | A0  | $\overline{\text{RD}}$ | $\overline{\text{WR}}$  | $\overline{\text{CS}}$ |    |                        |                        |                        |   |   |           |    |                        |                        |                        |   |   |           |    |   |                         |                        |   |   |   |   |   |   |   |   |   |   |   |   |   |   |
| 0                       | 0      | 80 series      | A0  | $\overline{\text{RD}}$ | $\overline{\text{WR}}$  | $\overline{\text{CS}}$ |    |                        |                        |                        |   |   |           |    |                        |                        |                        |   |   |           |    |   |                         |                        |   |   |   |   |   |   |   |   |   |   |   |   |   |   |
| 1                       | 0      | 68 series      | A0  | E                      | $\overline{\text{R/W}}$ | $\overline{\text{CS}}$ |    |                        |                        |                        |   |   |           |    |                        |                        |                        |   |   |           |    |   |                         |                        |   |   |   |   |   |   |   |   |   |   |   |   |   |   |
| 0                       | 1      | *              | *   | *                      | *                       | *                      |    |                        |                        |                        |   |   |           |    |                        |                        |                        |   |   |           |    |   |                         |                        |   |   |   |   |   |   |   |   |   |   |   |   |   |   |
| 1                       | 1      | *              | *   | *                      | *                       | *                      |    |                        |                        |                        |   |   |           |    |                        |                        |                        |   |   |           |    |   |                         |                        |   |   |   |   |   |   |   |   |   |   |   |   |   |   |
| $\overline{\text{CS}}$  | 1      | Input          | Active "L"<br>Inputs the chip select signal normally acquired by decoding the address bus signal when the MPU accesses the LCD controller.  |                        |                         |                        |    |                        |                        |                        |   |   |           |    |                        |                        |                        |   |   |           |    |   |                         |                        |   |   |   |   |   |   |   |   |   |   |   |   |   |   |

Table 4 Terminal Functions 2

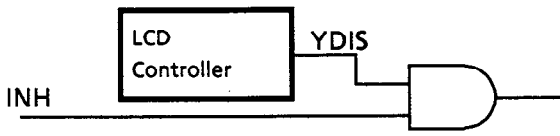
| Signal          | Q'ty                   | I/O                                     | Functions   |    |                 |                 |           |   |   |   |                           |   |   |   |   |   |   |   |  |   |   |   |                              |    |                        |   |           |   |   |   |                           |   |   |   |   |   |   |   |  |   |   |   |                              |
|-----------------|------------------------|---|---|----|-----------------|-----------------|-----------|---|---|---|---------------------------|---|---|---|---|---|---|---|--|---|---|---|------------------------------|----|------------------------|---|-----------|---|---|---|---------------------------|---|---|---|---|---|---|---|--|---|---|---|------------------------------|
| A0              | 1                      | Input                                   | <p>Normally connected to the least significant bit of MPU address. The data bus signal is identified by the combination of <math>\overline{RD}</math> and <math>\overline{WR}</math> or <math>R/\overline{W}</math> and E as shown in the following tables:</p> <p>&lt; 80 series interface &gt;</p> <table border="1"> <thead> <tr> <th>A0</th> <th><math>\overline{RD}</math></th> <th><math>\overline{WR}</math></th> <th>functions</th> </tr> </thead> <tbody> <tr> <td>0</td> <td>0</td> <td>1</td> <td>Reads out the status flag</td> </tr> <tr> <td>1</td> <td>0</td> <td>1</td> <td>Reads out the data (display data, cursor address)</td> </tr> <tr> <td>0</td> <td>1</td> <td>0</td> <td>Writes the data (display data, parameters)</td> </tr> <tr> <td>1</td> <td>1</td> <td>0</td> <td>Writes commands (only codes)</td> </tr> </tbody> </table> <p>&lt; 68 series interface &gt;</p> <table border="1"> <thead> <tr> <th>A0</th> <th><math>\overline{RD}</math><br/>(E)</th> <th><math>\overline{WR}</math><br/>(R/<math>\overline{W}</math>)</th> <th>functions</th> </tr> </thead> <tbody> <tr> <td>0</td> <td>1</td> <td>1</td> <td>Reads out the status flag</td> </tr> <tr> <td>1</td> <td>1</td> <td>1</td> <td>Reads out the data (display data, cursor address)</td> </tr> <tr> <td>0</td> <td>1</td> <td>0</td> <td>Writes the data (display data, parameters)</td> </tr> <tr> <td>1</td> <td>1</td> <td>0</td> <td>Writes commands (only codes)</td> </tr> </tbody> </table> | A0 | $\overline{RD}$ | $\overline{WR}$ | functions | 0 | 0 | 1 | Reads out the status flag | 1 | 0 | 1 | Reads out the data (display data, cursor address) | 0 | 1 | 0 | Writes the data (display data, parameters) | 1 | 1 | 0 | Writes commands (only codes) | A0 | $\overline{RD}$<br>(E) | $\overline{WR}$<br>(R/ $\overline{W}$ ) | functions | 0 | 1 | 1 | Reads out the status flag | 1 | 1 | 1 | Reads out the data (display data, cursor address) | 0 | 1 | 0 | Writes the data (display data, parameters) | 1 | 1 | 0 | Writes commands (only codes) |
| A0              | $\overline{RD}$        | $\overline{WR}$                         | functions   |    |                 |                 |           |   |   |   |                           |   |   |   |   |   |   |   |  |   |   |   |                              |    |                        |   |           |   |   |   |                           |   |   |   |   |   |   |   |  |   |   |   |                              |
| 0               | 0                      | 1                                       | Reads out the status flag   |    |                 |                 |           |   |   |   |                           |   |   |   |   |   |   |   |  |   |   |   |                              |    |                        |   |           |   |   |   |                           |   |   |   |   |   |   |   |  |   |   |   |                              |
| 1               | 0                      | 1                                       | Reads out the data (display data, cursor address)   |    |                 |                 |           |   |   |   |                           |   |   |   |   |   |   |   |  |   |   |   |                              |    |                        |   |           |   |   |   |                           |   |   |   |   |   |   |   |  |   |   |   |                              |
| 0               | 1                      | 0                                       | Writes the data (display data, parameters)  |    |                 |                 |           |   |   |   |                           |   |   |   |   |   |   |   |  |   |   |   |                              |    |                        |   |           |   |   |   |                           |   |   |   |   |   |   |   |  |   |   |   |                              |
| 1               | 1                      | 0                                       | Writes commands (only codes)  |    |                 |                 |           |   |   |   |                           |   |   |   |   |   |   |   |  |   |   |   |                              |    |                        |   |           |   |   |   |                           |   |   |   |   |   |   |   |  |   |   |   |                              |
| A0              | $\overline{RD}$<br>(E) | $\overline{WR}$<br>(R/ $\overline{W}$ ) | functions   |    |                 |                 |           |   |   |   |                           |   |   |   |   |   |   |   |  |   |   |   |                              |    |                        |   |           |   |   |   |                           |   |   |   |   |   |   |   |  |   |   |   |                              |
| 0               | 1                      | 1                                       | Reads out the status flag   |    |                 |                 |           |   |   |   |                           |   |   |   |   |   |   |   |  |   |   |   |                              |    |                        |   |           |   |   |   |                           |   |   |   |   |   |   |   |  |   |   |   |                              |
| 1               | 1                      | 1                                       | Reads out the data (display data, cursor address)   |    |                 |                 |           |   |   |   |                           |   |   |   |   |   |   |   |  |   |   |   |                              |    |                        |   |           |   |   |   |                           |   |   |   |   |   |   |   |  |   |   |   |                              |
| 0               | 1                      | 0                                       | Writes the data (display data, parameters)  |    |                 |                 |           |   |   |   |                           |   |   |   |   |   |   |   |  |   |   |   |                              |    |                        |   |           |   |   |   |                           |   |   |   |   |   |   |   |  |   |   |   |                              |
| 1               | 1                      | 0                                       | Writes commands (only codes)  |    |                 |                 |           |   |   |   |                           |   |   |   |   |   |   |   |  |   |   |   |                              |    |                        |   |           |   |   |   |                           |   |   |   |   |   |   |   |  |   |   |   |                              |
| D0 to D7        | 8                      | I/O                                     | <p>Active "H"<br/>Tristate input/output terminal<br/>8 bit bidirectional data bus. Connected to 8 bit or 16 bit MPU data bus.</p>   |    |                 |                 |           |   |   |   |                           |   |   |   |   |   |   |   |  |   |   |   |                              |    |                        |   |           |   |   |   |                           |   |   |   |   |   |   |   |  |   |   |   |                              |
| V <sub>DD</sub> | 1                      | -                                       | Power supply for logic circuit (+ 5 V)  |    |                 |                 |           |   |   |   |                           |   |   |   |   |   |   |   |  |   |   |   |                              |    |                        |   |           |   |   |   |                           |   |   |   |   |   |   |   |  |   |   |   |                              |
| V <sub>SS</sub> | 1                      | -                                       | GND (0 V)   |    |                 |                 |           |   |   |   |                           |   |   |   |   |   |   |   |  |   |   |   |                              |    |                        |   |           |   |   |   |                           |   |   |   |   |   |   |   |  |   |   |   |                              |
| V <sub>O</sub>  | 1                      | -                                       | Adjustment terminal for liquid crystal driving voltage  |    |                 |                 |           |   |   |   |                           |   |   |   |   |   |   |   |  |   |   |   |                              |    |                        |   |           |   |   |   |                           |   |   |   |   |   |   |   |  |   |   |   |                              |
| V <sub>LC</sub> | 1                      | -                                       | Power supply terminal for driving liquid crystal display(- 24 V)  |    |                 |                 |           |   |   |   |                           |   |   |   |   |   |   |   |  |   |   |   |                              |    |                        |   |           |   |   |   |                           |   |   |   |   |   |   |   |  |   |   |   |                              |
| INH             | 1                      | Input                                   | <p>When INH = "H", the display is ON and when INH = "L", the display is OFF.</p>    |    |                 |                 |           |   |   |   |                           |   |   |   |   |   |   |   |  |   |   |   |                              |    |                        |   |           |   |   |   |                           |   |   |   |   |   |   |   |  |   |   |   |                              |
| LEDA            | 1                      | -                                       | <p>G121C00P00C : NC<br/>G121CB1P00C : LED backlight anode terminal</p>  |    |                 |                 |           |   |   |   |                           |   |   |   |   |   |   |   |  |   |   |   |                              |    |                        |   |           |   |   |   |                           |   |   |   |   |   |   |   |  |   |   |   |                              |
| LEDC            | 1                      | -                                       | <p>G121C00P00C : NC<br/>G121CB1P00C : LED backlight cathode terminal</p>  |    |                 |                 |           |   |   |   |                           |   |   |   |   |   |   |   |  |   |   |   |                              |    |                        |   |           |   |   |   |                           |   |   |   |   |   |   |   |  |   |   |   |                              |



## 3.2 Timing Characteristics

### 3.2.1 Read/Write Characteristics(80 series MPU)

$T_a = -20\text{ }^\circ\text{C to } +70\text{ }^\circ\text{C}, V_{DD} = 5.0\text{ V} \pm 5\%, V_{SS} = 0\text{ V}$

| Signal                                       | Item                               | Symbol     | Min. | Typ. | Max. | Unit |
|--|------------------------------------|------------|------|------|------|------|
| A0, $\overline{\text{CS}}$                   | Address hold time                  | $t_{AH8}$  | 10   | —    | —    | ns   |
|  | Address setup time                 | $t_{AW8}$  | 0    | —    | —    | ns   |
| $\overline{\text{WR}}, \overline{\text{RD}}$ | System cycle time                  | $t_{CYC8}$ | *    | —    | —    | ns   |
|  | Control pulse width                | $t_{CC}$   | 120  | —    | —    | ns   |
| D0 to D7                                     | Data hold time                     | $t_{DH8}$  | 5    | —    | —    | ns   |
|  | Data setup time                    | $t_{DS8}$  | 120  | —    | —    | ns   |
|  | $\overline{\text{RD}}$ access time | $t_{ACC8}$ | —    | —    | 50   | ns   |
|  | Output disable time                | $t_{OH8}$  | 10   | —    | 50   | ns   |

\*  $t_{CYC8} = 785$  : Applies to "Memory control command" and "System control command."  
 $(t_{CYC8} = 2t_c + t_{CC} + t_{CEA} + 75 > t_{ACT} + 245)$

$t_{CYC8} = 820$  : Applies to all the commands except the commands above.  
 $(t_{CYC8} = 4t_c + t_{CC} + 30)$

#### Timing Chart

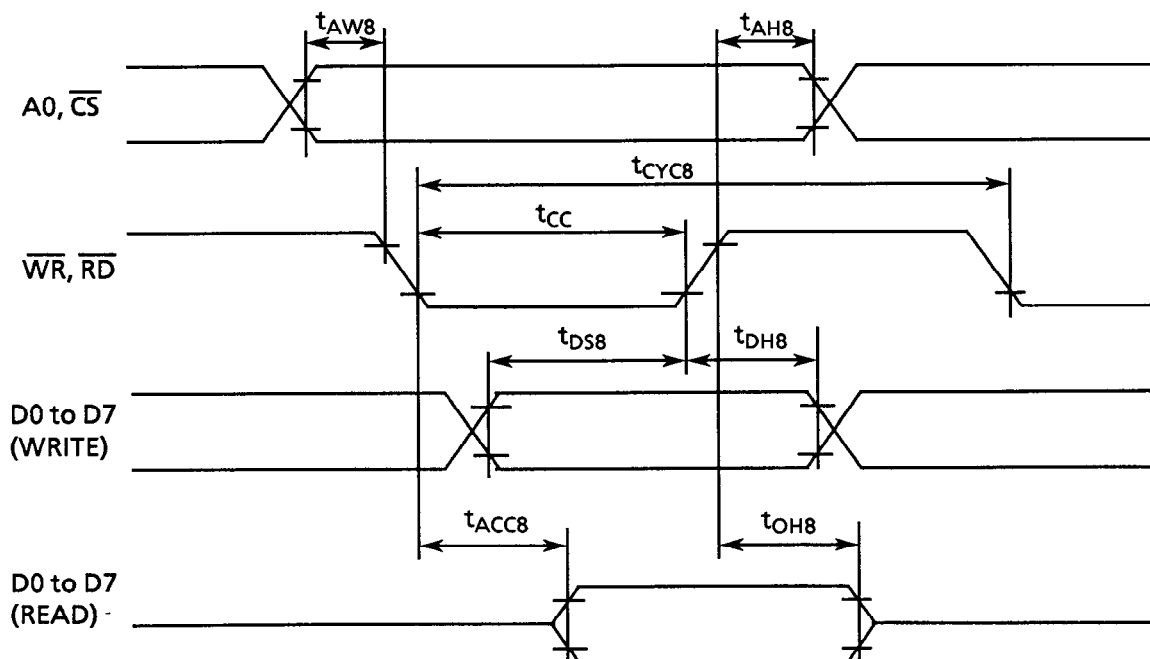

## 3.2.2 Read/Write Characteristics(68 series MPU)

 $T_a = -20^{\circ}\text{C to } +70^{\circ}\text{C}, V_{DD} = 5.0\text{ V} \pm 5\%, V_{SS} = 0\text{ V}$ 

| Signal                             | Item                | Symbol     | Min. | Typ. | Max. | Unit |
|------------------------------------|---------------------|------------|------|------|------|------|
| $A0, \overline{CS}, \overline{WR}$ | Address hold time   | $t_{AH6}$  | 0    | —    | —    | ns   |
|                                    | Address setup time  | $t_{AW6}$  | 0    | —    | —    | ns   |
|                                    | System cycle time   | $t_{CYC6}$ | *    | —    | —    | ns   |
| D0 to D7                           | Data hold time      | $t_{DH6}$  | 0    | —    | —    | ns   |
|                                    | Data setup time     | $t_{DS6}$  | 100  | —    | —    | ns   |
|                                    | Access time         | $t_{ACC6}$ | —    | —    | 85   | ns   |
|                                    | Output disable time | $t_{OH6}$  | 10   | —    | 50   | ns   |
| $\overline{RD}$                    | Enable pulse width  | $t_{RDW}$  | 120  | —    | —    | ns   |

\*  $t_{CYC6} = 785$ : Applies to "Memory control command" and "System control command."  
 $(t_{CYC6} = 2t_c + t_{RDW} + t_{CEA} + 75 > t_{ACV} + 245)$

$t_{CYC6} = 820$ : Applies to all the commands except the commands above.  
 $(t_{CYC6} = 4t_c + t_{CC} + 30)$

Note:  $t_{CYC6}$  indicates the cycle of  $\overline{RD}(E)$  signal while  $\overline{CS} \cdot \overline{RD}(E) = "H."$  It doesn't unconditionally indicate the cycle of  $\overline{RD}(E)$  signal.

## Timing Chart

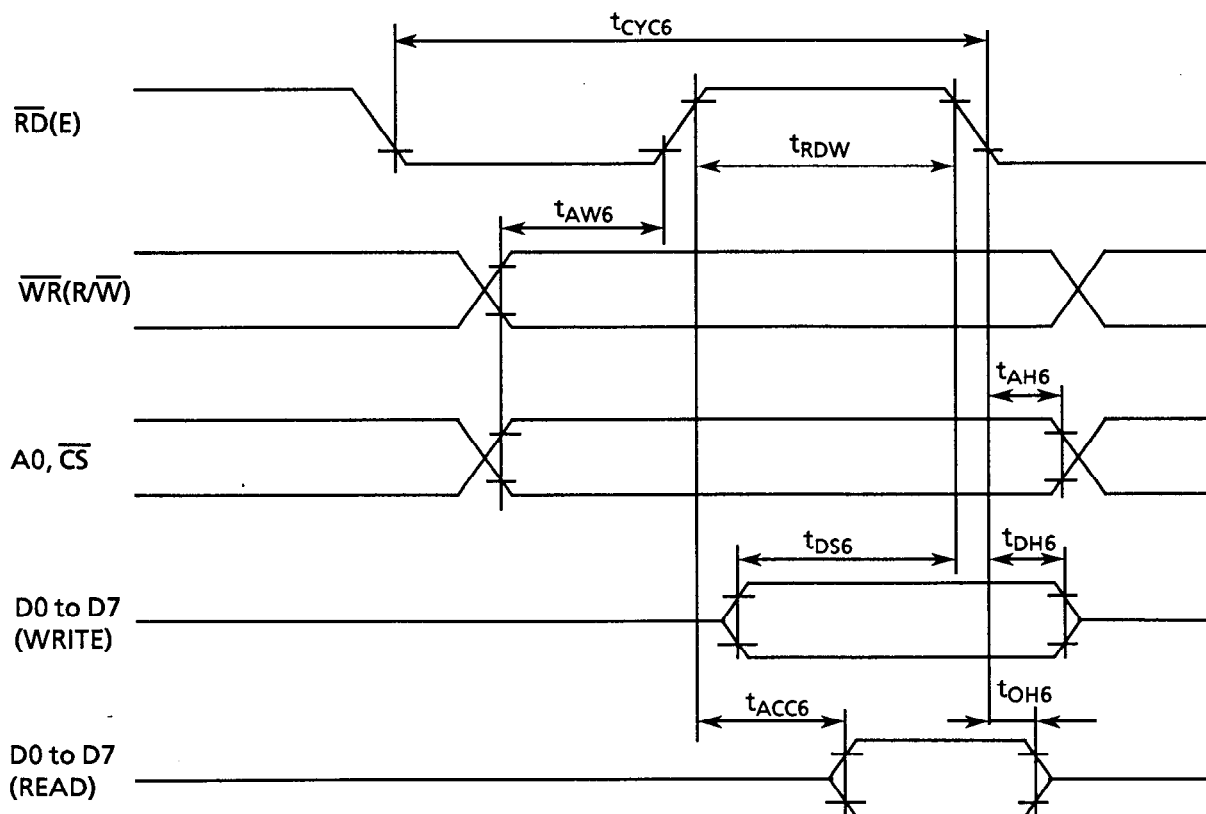

### 3.3 Reset

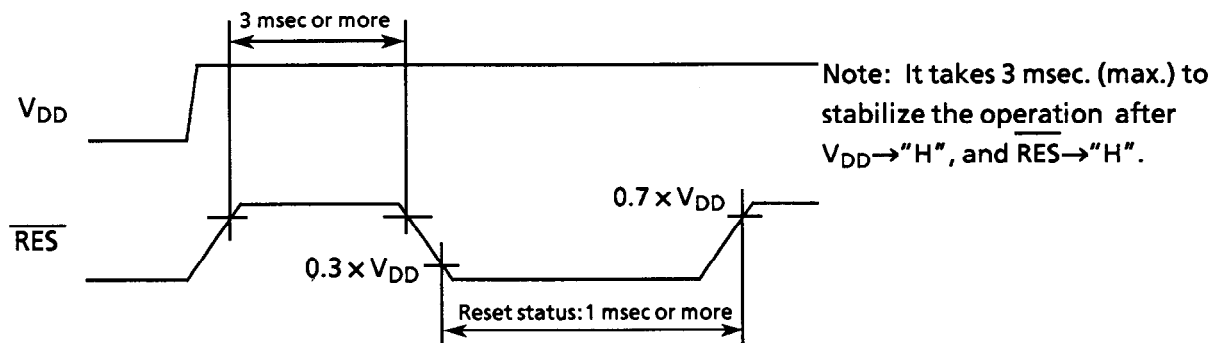

Figure 7 Reset

Inputting reset pulse resets the internal status of the LCD controller after powering on. The width of the pulse input must be 1 msec or more.

The control signal for the LCD is cut off when in the reset status. Consequently, the LCD is driven by DC and the display quality deteriorates. Therefore, set  $\overline{\text{INH}}$  to L to reset in the status in which DC is not applied to LCD. The instructions from the CPU cannot be accepted during this period. After resetting, set the default values immediately in order to set the internal registers after resetting.

### 3.4 Setting the Power Supply and the Signals to On or Off

Set the Power supply and the signals to on or off according to the following timing chart list to avoid malfunctions of the drive circuit and the LC panel.

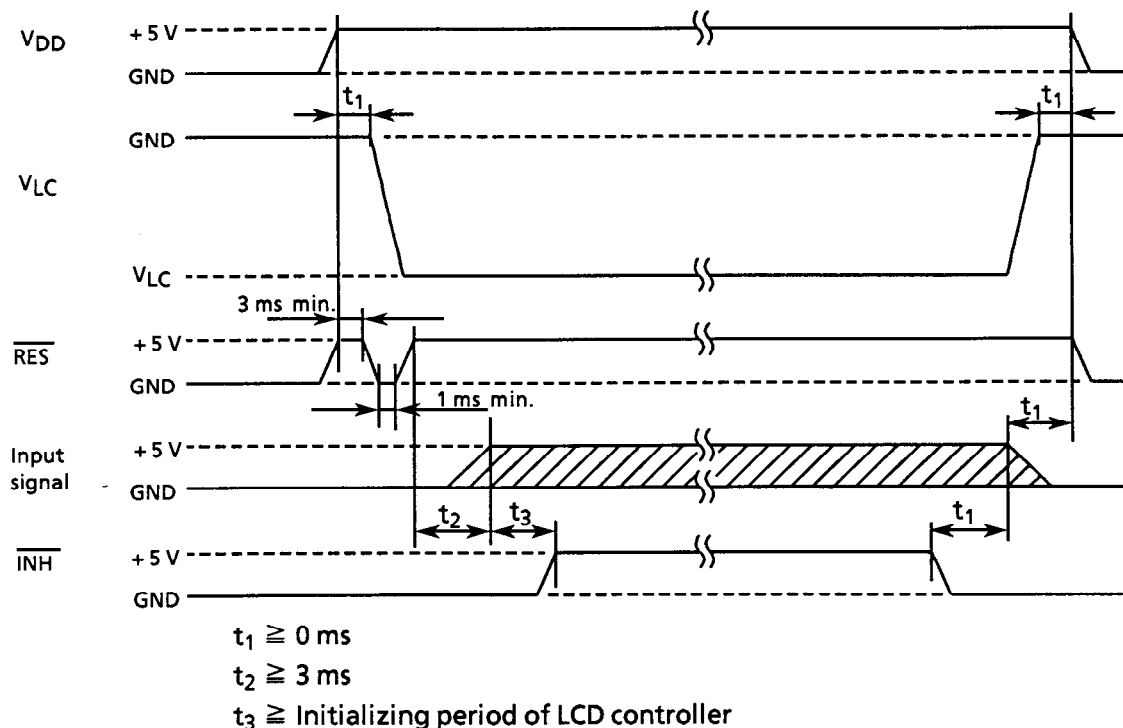

Figure 8 Timing of setting the power supply and the signals to on and off

## 3.5 Commands

Table 5 Commands

| Purpose         | Command     | Code     |                         | HEX            | Description  | Parameters | Remarks |
|-----------------|-------------|----------|-------------------------|----------------|--|------------|---------|
|                 |             | RD WR A0 | D7 D6 D5 D4 D3 D2 D1 D0 |                |  |            |         |
| System Control  | SYSTEM SET  | 1 0 1    | 0 1 0 0 0 0 0 0         | 40             | Setting the initial operation and the window                       | P1 to P8   | Note1   |
|                 | SLEEP IN    | 1 0 1    | 0 1 0 1 0 0 1 1         | 53             | Sleep Operation  | 0          |         |
| Display Control | DISP ON/OFF | 1 0 1    | 0 1 0 1 1 0 0 D         | 58<br>59       | Display on/off, flashing screen                                    | P1         |         |
|                 | SCROLL      | 1 0 1    | 0 1 0 0 0 1 0 0         | 44             | Setting display start address and the display area                 | P1 to P10  | Note 1  |
|                 | CSRFORM     | 1 0 1    | 0 1 0 1 1 1 0 1         | 5D             | Setting the shape of the cursor, etc.                              | P1, P2     |         |
|                 | CGRAM ADR   | 1 0 1    | 0 1 0 1 1 1 0 0         | 5C             | Setting CG RAM start address                                       | P1, P2     | Note 1  |
|                 | CSRDIR      | 1 0 1    | 0 1 0 0 1 1 1 0         | 4C<br>to<br>4F | Setting the cursor movement direction                              | 0          |         |
|                 | HDOT SCR    | 1 0 1    | 0 1 0 1 1 0 1 0         | 5A             | Setting the scrolling position per dot in the horizontal direction | P1         |         |
|                 | OVLAY       | 1 0 1    | 0 1 0 1 1 0 1 1         | 5B             | Display overlaying mode  | P1         |         |
| Drawing Control | CSRW        | 1 0 1    | 0 1 0 0 0 1 1 0         | 46             | Setting cursor address   | P1, P2     | Note 1  |
|                 | CSRR        | 1 0 1    | 0 1 0 0 0 1 1 1         | 47             | Reading cursor address   | P1, P2     | Note 1  |
| Memory Control  | MWRITE      | 1 0 1    | 0 1 0 0 0 0 1 0         | 42             | Writing into display memory  | —          |         |
|                 | MREAD       | 1 0 1    | 0 1 0 0 0 0 1 1         | 43             | Reading display memory data  | —          |         |

Note 1) A command is executed every time each parameter is input to the LCD controller and completed when the following parameters (P) or command (C) is entered. Consequently, the MPU can abort sending the parameters and send the following command. In this case the parameters which have been sent are effective and the values of the remaining parameters which have not been sent remain unchanged. Note that 2 byte parameters are handled as follows:

- ① CSRW and CSRR commands : Parameters are executed per byte. Consequently only the lower bytes can be changed or checked.
- ② All the commands but CSRW and CSRR commands : Executed after the second byte of the parameter is entered.

(SYSTEM SET, SCROLL, CGRAM ADR)

\* 2 byte parameter indicates 1 data with 2 bytes such as APL and APH.

For a description of commands and their parameters, refer to "SED1335F/1336F LCD Controller IC Application Manual" (Seiko Epson Corporation).

### 3.6 Display Data RAM

The built-in LCD controller can control 512 Kbit (0000H to FFFFH) of the VRAM area. However, because the G121C has only 64 Kbit of built-in VRAM, the upper 3 bits are not effective. Consequently, when you define the addresses over 2000H, the display data is destroyed because the data is mapped to the VRAM area defined by the lower 13 bits. Do not map the data onto addresses over 2000H.

When you define 65 or more customized character fonts (max. 256 characters) on CGRAM and display them simultaneously, you must map them onto VRAM addresses F000H through FFFFH. Note that this corresponds to 1000H through 1FFFH in VRAM of the G121C. Because all the character codes are assigned to CGRAM, the built-in CGROM cannot be used together with CGRAM.

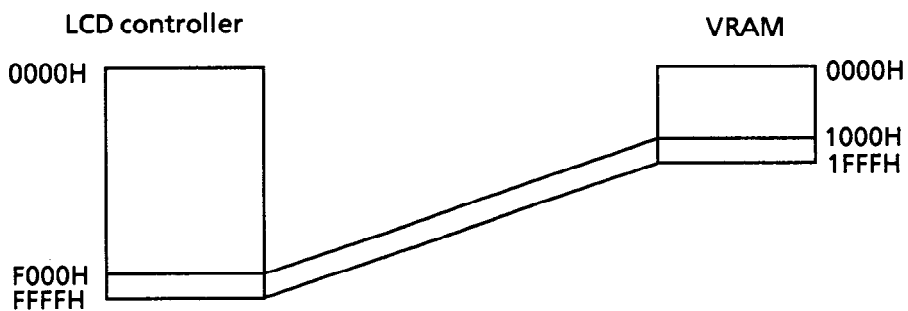
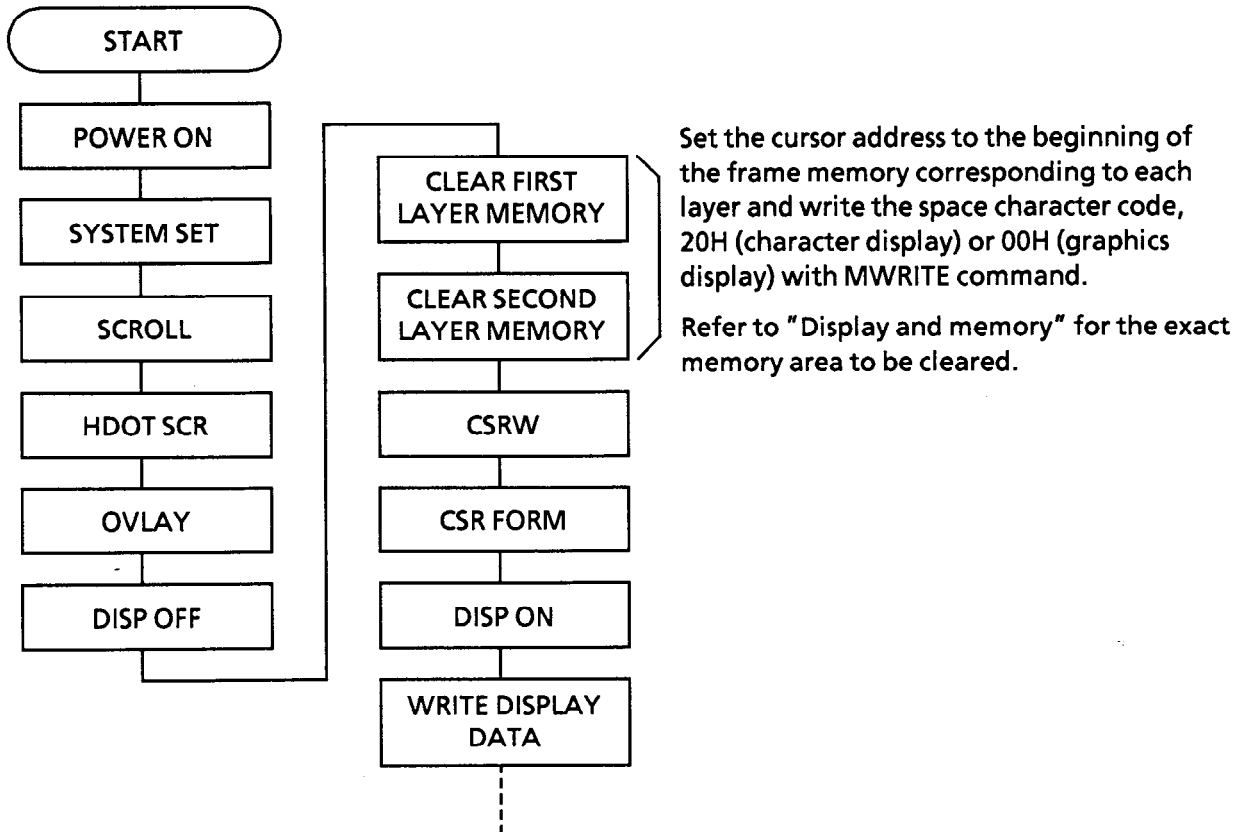

Figure 9 Display Data RAM

### 3.7 Example of an Initial Setting



## In the combination of characters and graphics

- Requirements
  - 128 × 128 dots : 1 screen driving method (1/128 duty)
  - First layer : Character screen
  - Second layer : Graphics screen
  - Character font : 8 × 8 dots
  - CG RAM unused
  - fosc = 6 MHz, Frame frequency = 71.2 Hz
- Assigning display memory
  - First layer (Character screen)
    - Characters in the horizontal direction =  $128/8 = 16$
    - Characters in the vertical direction =  $128/8 = 16$
    - Consequently, the required memory size is  $16 \times 16 = 256$  bytes.
  - Second layer (Graphics screen)
    - Characters in the horizontal direction =  $128/8 = 16$
    - Characters in the vertical direction =  $128/1 = 128$
    - Consequently, the required memory size is  $16 \times 128 = 2048$  bytes

[Display and memory]

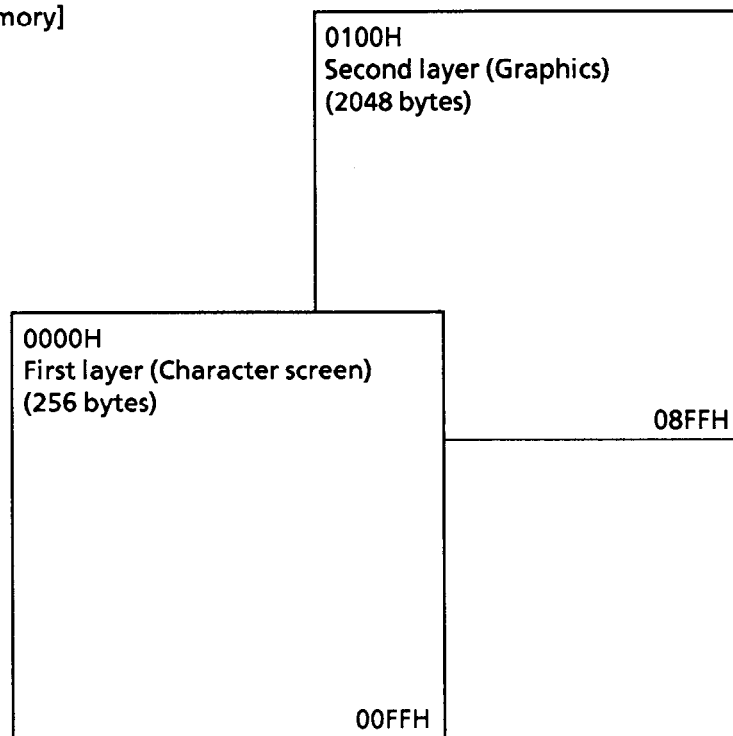
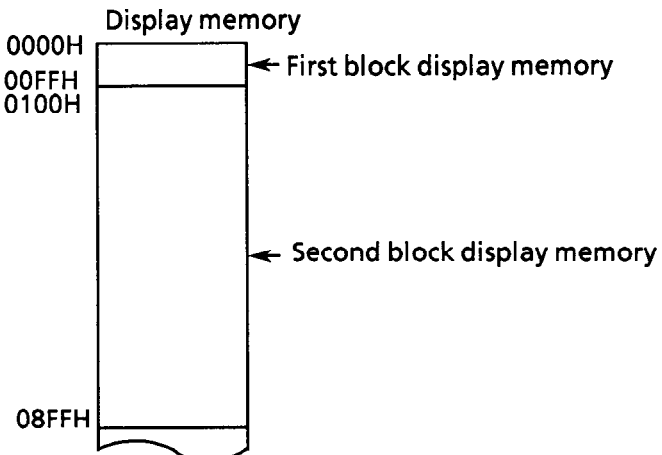
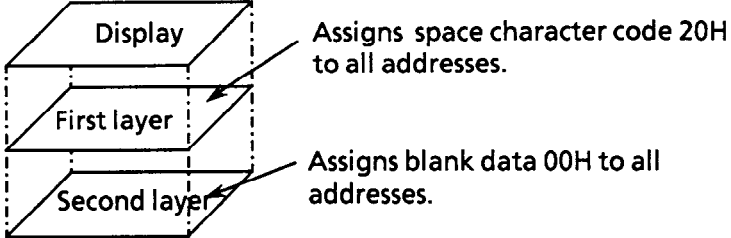

Figure 11 Display and memory

| No. | Command   | Operation  |
|-----|---|--|
| 1   | POWER ON  |  |
| 2   | WAIT FOR POWER SUPPLY TO BE STABILIZED  | Sets $V_{DD} \geq 4.5$ V and waits more than 3 msec after completing external resetting.   |
| 3   | SYSTEM SET<br>C = 40H<br>P1 = 30H<br><br>P2 = 87H<br><br>P3 = 07H<br>P4 = 0FH<br><br>P5 = 49H<br><br>P6 = 7FH<br><br>P7 = 10H<br>P8 = 00H | Initializes LCD controller<br><br>M0 : Internal CG ROM<br>M1 : No compensation in bit D6 (CG RAM 32 characters MAX.)<br>M2 : Character font size in the Y direction (8 dots)<br>W/S : 1 screen driving method<br>IV : No compensation in the top line<br><br>FX : Character field in the X direction (8 dots)<br>WF : 2-frame AC drive<br><br>FY : Character field in the Y direction (8 dots)<br><br>C/R : Characters in the X direction (Number of addresses)<br>(16 characters/line)<br><br>TC/R : Total characters in the X direction (Number of addresses)<br>(73 characters/line)<br>fosc = 6 MHz, Frame frequency = 71.2Hz<br><br>L/F : Display lines in the Y direction (128)<br><br>AP : Addresses in the X direction of virtual screen<br>(16 addresses) |
| 4   | SCROLL<br>C = 44H<br>P1 = 00H<br>P2 = 00H<br><br>P3 = 7FH<br><br>P4 = 00H<br>P5 = 01H<br><br>P6 = 7FH                                     | Sets the start address of the first block screen to 0000H.<br><br>Sets the display lines of the first block screen to 128.<br><br>Sets the start address of the second block screen to 0100H.<br><br>Sets the display lines of the second block screen to 128.<br><br>   |

| No. | Command  | Operation  |
|-----|--|--|
| 5   | <b>HDOT SCR</b><br>C = 5AH<br>P1 = 00H   | Sets the dot shift in the X direction to 0.  |
| 6   | <b>OVLAY</b><br>C = 5BH<br>P1 = 00H  | MX1, MX0 : Simple overlay (OR)<br>DM1 : First block screen (character mode)<br>DM2 : Third block screen (character mode)<br>OV : Combination of character mode and graphics mode   |
| 7   | <b>DISP ON/OFF</b><br>C = 58H<br>P1 = 16H  | D : All screen display OFF<br>FC1, FC0 : Blinking with cursor ON (Approx.2 Hz)<br>FP1, FP0 : First block screen display ON<br>FP3, FP2 : Second block screen display ON<br>FP5, FP4 : Third block screen display OFF   |
| 8   | <b>CLEAR FIRST LAYER DISPLAY DATA</b><br><br><b>CSRW</b><br>C = 46H<br>P1 = 00H<br>P2 = 00H<br><br><b>CSR DIR</b><br>C = 4CH<br><br><b>MWRITE</b><br>C = 42H<br>P1 = 20H<br>P2 = 20H<br>.<br>.<br>.<br>Pn = 20H, (n = 256) | Writes space character code 20H onto the corresponding first layer memory (character screen).<br><br>Sets the VRAM address corresponding to the start address of the first block screen (home address).<br><br>Sets " + 1" to the automatic shift direction of the address counter.<br><br>Sets the space code.<br>Sets the space code.<br>.<br>.<br>.<br>Sets the space code. |
|     |  |    |



| No. | Command   | Operation  |
|-----|---|--|
| 9   | <p>CLEAR SECOND LAYER DISPLAY DATA</p> <p>CSRW<br/>C = 46H<br/>P1 = 00H<br/>P2 = 01H</p> <p>MWRITE<br/>C = 42H<br/>P1 = 00H<br/>P2 = 00H<br/>.<br/>.<br/>.<br/>Pm = 00H, (m = 2048)</p> | <p>Writes blank data 00H (dot light OFF) onto the corresponding memory of the second layer (graphics screen).</p> <p>Sets the VRAM address corresponding to the start address of the second block screen (home address).</p> <p>Sets the blank data.<br/>Sets the blank data.<br/>.<br/>.<br/>.<br/>Sets the blank data.</p>   |
| 10  | <p>CSRW<br/>C = 46H<br/>P1 = 00H<br/>P2 = 00H</p>   | <p>Sets the cursor address to the start address of the first block screen (home position).</p>   |
| 11  | <p>CSR FORM<br/>C = 5DH<br/>P1 = 04H<br/>P2 = 86H</p>   | <p>CRX : Cursor size in the X direction (5 dots)<br/>CRY : Cursor size in the Y direction (7 dots)<br/>CM : Block cursor</p>   |
| 12  | <p>DISP ON/OFF<br/>C = 59H</p>  | <p> Cancels "All screen display OFF".</p> <div data-bbox="1123 1155 1399 1413" style="border: 1px solid black; width: 173px; height: 115px; position: relative;"> <div data-bbox="1123 1155 1139 1189" style="position: absolute; top: 0; left: 0; width: 10px; height: 10px; background-color: black;"></div> </div> <p style="text-align: right; margin-right: 100px;">Screen</p>  |
| 13  | <p>CSR DIR<br/>C = 4CH</p>  | <p>Sets the cursor shift direction to right.</p>   |
| 14  | <p>MWRITE<br/>C = 42H<br/>P1 = 20H<br/>P2 = 53H<br/>P3 = 49H<br/>P4 = 49H<br/>.<br/>.<br/>.</p>   | <p>Sets the space code.<br/>Sets the character code of "S."<br/>Sets the character code of "I."<br/>Sets the character code of "I."<br/>.<br/>.<br/>.</p> <div data-bbox="1123 1644 1399 1904" style="border: 1px solid black; width: 173px; height: 116px; position: relative;"> <div data-bbox="1123 1644 1209 1688" style="position: absolute; top: 0; left: 0; width: 54px; height: 20px; background-color: black; display: flex; align-items: center;"> <span style="margin-right: 5px;">S</span> <span style="margin-right: 5px;">I</span> <span style="margin-right: 5px;">I</span> <span style="width: 10px; height: 10px; background-color: black; margin-left: 5px;"></span> </div> </div> <p style="text-align: right; margin-right: 100px;">Screen</p> |

### 3.8 Example of the MPU Interface

#### 3.8.1 80 series

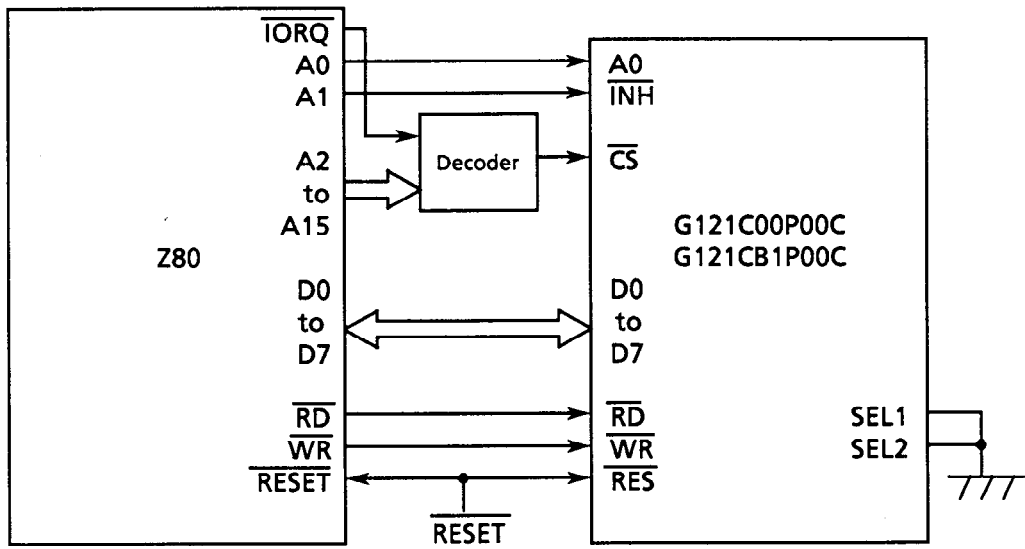

Figure 12

#### 3.8.2 68 series

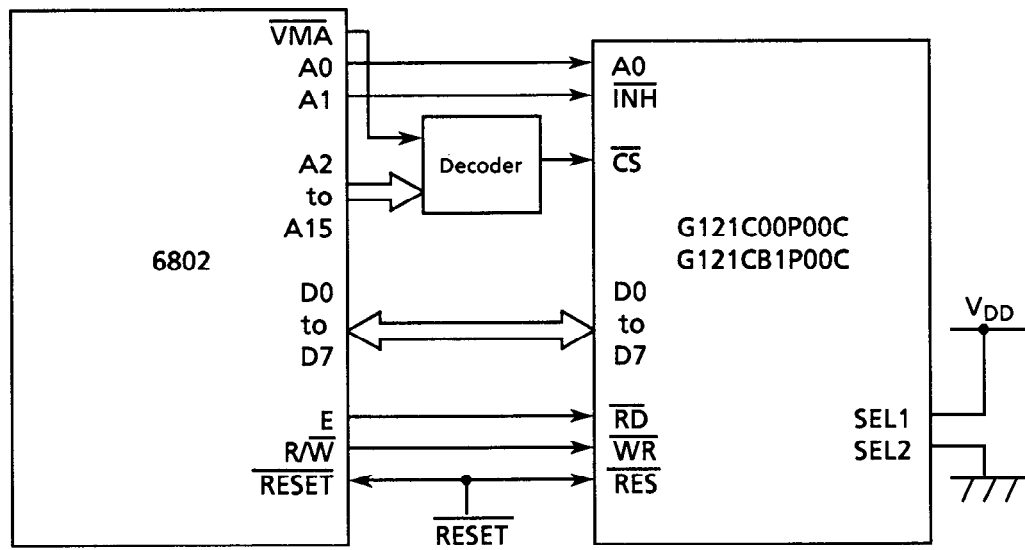

Figure 13

#### 4. LED BACKLIGHT

##### 4.1 Absolute Maximum Ratings

| Item                        | Symbol    | Standard     | Unit |
|-----------------------------|-----------|--------------|------|
| DC forward current          | $I_F$     | 200*         | mA   |
| DC reverse voltage          | $V_R$     | 8            | V    |
| Allowable dissipation       | $P_D$     | 950          | mW   |
| Operating temperature range | $T_{opr}$ | - 20 to + 70 | °C   |
| Storage temperature range   | $T_{stg}$ | - 30 to + 80 | °C   |

\* Forward current reduction characteristics :The absolute maximum ratings of forward current depends on the ambient temperature.

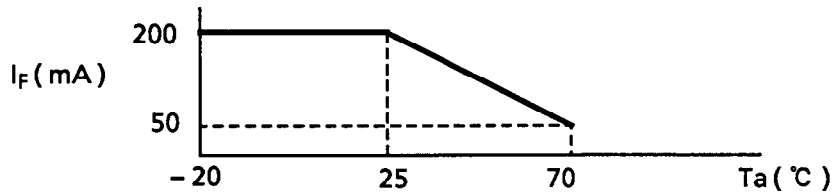

##### 4.2 Electro-optical Characteristics

$T_a = 25^\circ\text{C}$

| Item            | Symbol | Conditions             | Min. | Typ. | Max. | Unit          |
|-----------------|--------|------------------------|------|------|------|---------------|
| Forward voltage | $V_F$  | $I_F = 100 \text{ mA}$ | 3.7  | 4.1  | 4.5  | V             |
| Reverse current | $I_R$  | $V_R = 8 \text{ V}$    | -    | -    | 300  | $\mu\text{A}$ |

##### 4.3 LED Backlight Diagram

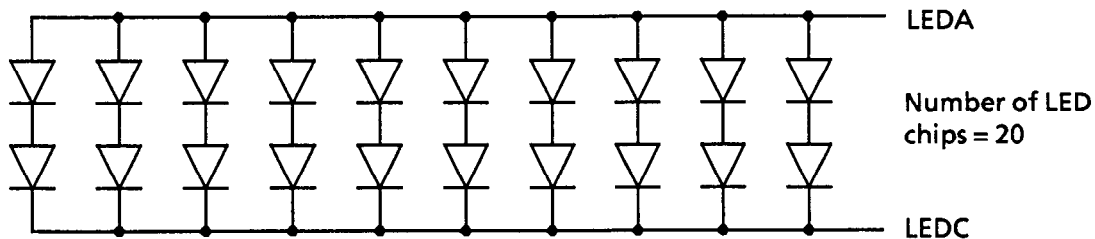

##### 4.4 Brightness (Top surface of LCD)

| Item   | Symbol | Min. | Typ. | Max. | Unit |
|--|--------|------|------|------|------|
| Surface brightness<br>(Center part of LCD panel) | $B_p$  | 1.0  | 1.7  | -    | nit  |

Measurement conditions and measuring instruments

- $T_a = 25^\circ\text{C} \pm 3^\circ\text{C}$
- $I_F = 100 \text{ mA}$
- $V_{LC}$ : Optimum LCD driving voltage
- The measurements must be made after LED lights for 30 minutes.
- Measuring instrument : BM - 7 ( TOPCON )
- 30 to 85% RH
- $f_{FLM} = 71.4 \text{ Hz}$
- Display OFF ( All display data = "L" )

4.5 Lifetime

| Item      | Measurement conditions          | Standard       | Unit |
|-----------|---------------------------------|----------------|------|
| Lifetime* | Ta = 25°C ± 10°C<br>If = 100 mA | 50,000 or more | hrs  |

\* Definition of lifetime: Time required for the brightness to be reduced to 1/2 of the initial brightness.

4.6 Examples of LED Backlight Drivers

(1) Circuit Example 1

Figure 14 shows an example of a basic LED backlight driver.

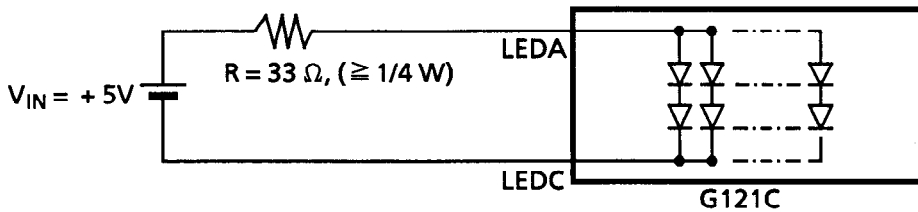

Figure 14 LED Backlight Driver Example 1

The resistance R in the figure is a limiting resistor for the LED forward current and determines the current that flows into the LEDs. The forward current is temperature-dependent. Therefore the current must be reduced, especially at higher temperatures. Refer to "Forward Current reduction characteristics" in 4.1 for the temperature-dependency. Because the operating temperature range of the G121C is - 20 °C through + 70 °C, the limiting resistance must be determined so that the forward current is 50 mA or less at + 70 °C.

Table 6 shows forward voltage VF of LED backlight at each temperature.

Table 6 Forward voltage at each temperature

| Temperature(Ta) | Requirements | VF min. | VF typ. | VF max. |
|-----------------|--------------|---------|---------|---------|
| - 20°C          | If = 100 mA  | 3.9 V   | 4.3 V   | 4.7 V   |
| + 25°C          | If = 100 mA  | 3.7 V   | 4.1 V   | 4.5 V   |
| + 70°C          | If = 50 mA   | 3.4 V   | 3.6 V   | 3.9 V   |

The resistance value R is calculated using the following equation. See Figure 14.

$$R = \frac{V_{IN} - V_F}{I_F} \quad (\Omega)$$

$V_{IN}$  = Input voltage (Power supply voltage)(V)  
 $V_F$  = LED forward voltage(V)  
 $I_F$  = Allowable LED forward current (A)

The forward current on the above value of the resistance is 50mA or less at 25°C. The surface brightness of the LED backlight varies according to the forward current as shown in Figure 15. Consequently, the brightness becomes 30% compared to the case described in "4.4 brightness" (If = 100 mA).

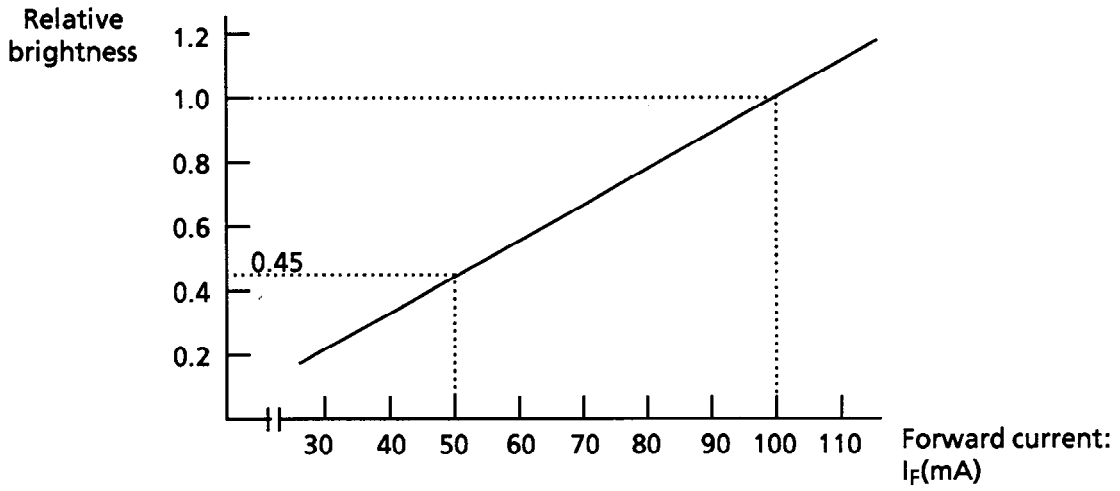

Figure 15 Forward Current-Brightness Characteristics ( $T_a = 25^\circ\text{C}$ )

(2) Circuit Example 2

Using a thermo-sensitive device such as a thermistor and a transistor, set them to approximately  $I_F = 100\text{ mA}$  at  $25^\circ\text{C}$  and design the circuit so that  $I_F$  becomes less as the temperature rises to assure the brightness at  $25^\circ\text{C}$  (2 nit).

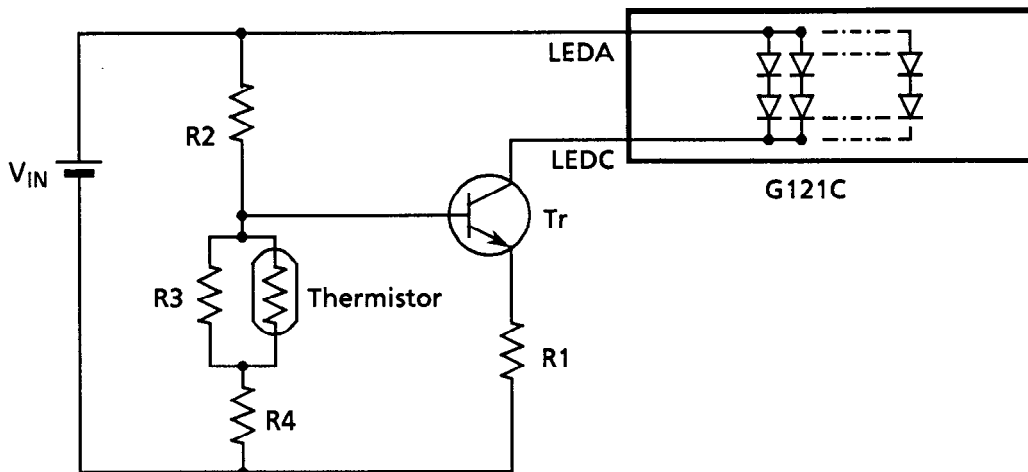

Figure 16 LED Backlight Driver Example 2

## 5. PRECAUTIONS

### Safety

- If the LCD panel is damaged, be careful not to get the liquid crystal in your mouth and not to be injured by crushed glasses.
- If you should swallow the liquid crystal, first, wash your mouth thoroughly with water, then, drink a lot of water and induce vomiting; and then, consult a physician.
- If the liquid crystal should get in your eye, flush your eye with running water for at least fifteen minutes.
- If the liquid crystal touches your skin or clothes, remove it and wash the affected part of your skin or clothes with soap and running water.
- Use the LCD module within the rated voltage to prevent overheating and/or damage. Also, take steps to ensure that the connector dose not come off.

### Handling

- Avoid static electricity, as it will damage the CMOS LSI.
- The LCD panel is made of plate glass. Do not hit , crush, or bend it.
- Do not remove the panel or frame from the module.
- The polarizer of the display is very fragile. Handle it with care.

### Mounting and design

- Mount the module using the specified mounting parts and holes.
- To protect the module against external pressure, place a transparent plate (e.g., acrylic or glass) on the module, leaving a small gap between the display surface and transparent plate.

#### ☆Example

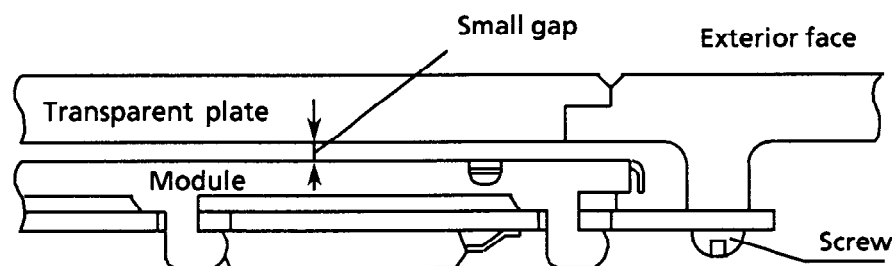

- Keep the module dry. Avoid condensation to prevent the transparent electrodes from being damaged.

### Storage

- Store the module in a dark place, where the temperature is  $25\text{ }^{\circ}\text{C} \pm 10\text{ }^{\circ}\text{C}$  and the relative humidity is below 65%.
- Do not store the module near organic solvents or corrosive gases.
- Keep the module (including accessories) safe from vibration, mechanical shock and external pressure.
- Black or white air-bubbles may be produced if the module is stored for a long time in the lower temperature or mechanical shocks are applied onto the module.

### Cleaning

- Do not wipe the polarizer with a dry cloth, as it may scratch the surface.
- Wipe the module gently with a soft cloth soaked with a petroleum benzine.
- Do not use ketonic (ketone) solvents (ketone and acetone) or aromatic solvents (toluene and xylene), as they may damage the polarizer.

## INDEX

**- A -**

|  |    |
|--|----|
| Adjustment terminal for liquid crystal driving voltage ..... | 7  |
| Allowable dissipation .....                                  | 24 |

**- B -**

|                              |            |
|------------------------------|------------|
| Bias .....                   | 1, 4, 11   |
| Bias voltage generator ..... | 8, 11      |
| Block diagram .....          | 8          |
| Brightness .....             | 24, 25, 26 |

**- C -**

|                             |                        |
|-----------------------------|------------------------|
| CG RAM .....                | 18, 19                 |
| CG ROM .....                | 1, 18                  |
| Cleaning .....              | 27                     |
| Commands .....              | 13, 14, 15, 17, 18, 20 |
| Common drive waveform ..... | 9                      |
| Common driver .....         | 8, 9                   |
| Contrast .....              | 4, 5                   |
| Current consumption .....   | 3                      |

**- D -**

|                                   |          |
|-----------------------------------|----------|
| Definition of angle .....         | 5        |
| Definition of contrast .....      | 5        |
| Definition of response time ..... | 5        |
| Definition of viewing angle ..... | 5        |
| Display data RAM .....            | 1, 8, 18 |
| Display data shift clock .....    | 9        |
| Display on/off .....              | 7        |
| Dot dimensions .....              | 2        |
| Dot pitch .....                   | 2        |
| Drive waveform .....              | 9        |

**- F -**

|                       |              |
|-----------------------|--------------|
| Forward current ..... | 24, 25, 26   |
| Forward voltage ..... | 24, 25       |
| Frame frequency ..... | 3, 5, 19, 20 |

**- I -**

|                              |           |
|------------------------------|-----------|
| I/O terminal functions ..... | 7         |
| Initialize .....             | 7, 16, 18 |

|   |                                    |
|---|------------------------------------|
| Input voltage .....                             | 3, 25                              |
| Interface .....                                 | 1, 12, 13, 24                      |
| <b>- L -</b>                                    |                                    |
| LCD controller .....                            | 1, 7, 8, 9, 10, 12, 13, 16, 17, 18 |
| LC operating voltage .....                      | 7, 10, 13                          |
| Lifetime .....                                  | 6, 25                              |
| Limiting resistor .....                         | 25                                 |
| <b>- M -</b>                                    |                                    |
| M' generator .....                              | 8, 11                              |
| <b>- O -</b>                                    |                                    |
| One-common line timing signal .....             | 9, 11                              |
| One-frame timing signal .....                   | 9, 11                              |
| Operating temperature .....                     | 2, 24                              |
| Operational amplifier .....                     | 10, 11                             |
| <b>- P -</b>                                    |                                    |
| Power supply voltage .....                      | 2, 25                              |
| <b>- R -</b>                                    |                                    |
| Forward current reduction characteristics ..... | 24, 25                             |
| Reset .....                                     | 7, 16                              |
| Resistance division .....                       | 11                                 |
| Response time .....                             | 4, 5                               |
| Reverse current .....                           | 24                                 |
| <b>- S -</b>                                    |                                    |
| SED1335F .....                                  | 1, 8, 9, 17                        |
| Segment drive waveform .....                    | 10                                 |
| Segment driver .....                            | 8, 9                               |
| Storage .....                                   | 27                                 |
| Storage humidity .....                          | 2                                  |
| Storage temperature .....                       | 2, 24                              |
| <b>- T -</b>                                    |                                    |
| Timing .....                                    | 14, 15, 16                         |
| <b>- V -</b>                                    |                                    |
| Viewing angle .....                             | 4                                  |
| Viewing area .....                              | 2                                  |
| V <sub>opr</sub> control circuit .....          | 8, 10                              |



## **Seiko Instruments Inc.**

### **Head Office**

Components Sales Department  
1-8, Nakase, Mihama-ku, Chiba-shi, Chiba 261, Japan  
Phone: 043-211-1216 FAX: 043-211-8035

### **Seiko Instruments U.S.A. Inc.**

Electronic Components Division  
2990 W. Lomita Blvd., Torrance Calif. 90505, USA Phone: 310-517-7770 FAX: 310-517-7792

### **Seiko Instruments GmbH**

Siemensstrasse 9b, 63263 Neu-Isenburg, Germany Phone: 49-6102-297-0 FAX: 49-6102-297-222

### **Seiko Instruments (H. K.) Ltd. Sales Division**

4-5/F, Wyler Centre 2, 200 Tai Lin Pai Road, Kwai Chung, N.T., Kowloon, Hong Kong  
Phone: 852-24218611 FAX: 852-24805479

### **Seiko Instruments Taiwan Inc.**

5F-1 No. 99, SEC.2, Chung Shan N. Rd., Taipei 104, Taiwan, R.O.C.  
Phone: 886-2-563-5001 FAX: 886-2-521-9519

### **Seiko Instruments Singapore Pte. Ltd**

2, Marsiling Lane Woodland New Town Singapore 2573  
Phone: 65-2691370 FAX: 65-2699729