

DESCRIPTION

The SSI 32R2412R is a BiCMOS monolithic integrated circuit designed for use with two-terminal recording heads. It provides a low noise read amplifier, write current control, and data protection circuitry for up to four channels. The SSI 32R2412R option provides several internal damping resistors: 350Ω, 500Ω, and 800Ω. Damping resistor is switched in during write mode and switched out during read mode. The SSI 32R2412 option does not provide a damping resistor. The 32R2412R has an optional feature to boost the write current to improve rise/fall times. With write current boost, the damping resistor options are 225, 275, 350 and 500Ω. Power supply fault protection is provided by disabling the write current generator during power sequencing. System write to read recovery time is significantly improved by making the read channel outputs high impedance. The device also offers multiple channel "servo bank write" capability to assist in servo writing operations.

The SSI 32R2412R requires only a +5V power supply and are available in a variety of packages. The SSI 32R2412R is hardware compatible with the SSI 32R2210/11/12R Read/Write devices.

FEATURES

- **+5V ±10% supply**
- **Low power**
 - PD = 100 mW read mode (Nom)
 - PD = 1.0 mW Idle (Max)
- **High Performance**
 - Read mode gain = 200, 250, 300, 350 V/V
 - Input noise = 0.45 nV/√Hz (Nom)
 - Input capacitance = 6 pF (Nom)
 - Write current range = 3-20 mA
 - Nominal write current (10 mA) rise/fall time = 2.0 ns (Nom) (0.5 μH head)
 - Head voltage swing = 8 Vp-p (Nom)
- **Servo bank-write capability**
- **Self switching damping resistance**
- **Write unsafe detection**
- **Power supply fault protection**
- **Head short to ground protection**
- **Differential ECL-like (32R2410R/12R) or TTL (32R2411R) write data inputs**
- **Write Data Flip/Flop (32R2410R/11R) or no Flip/Flop (32R2412R)**
- **24-lead VSOP, isolated head pin out (32R2414R)**
- **Servo enable by pulling HS0 high (32R2413R)**

SSI 32R2412R

+5V, 2, 4-Channel Thin Film

Read/Write Device

BLOCK DIAGRAM

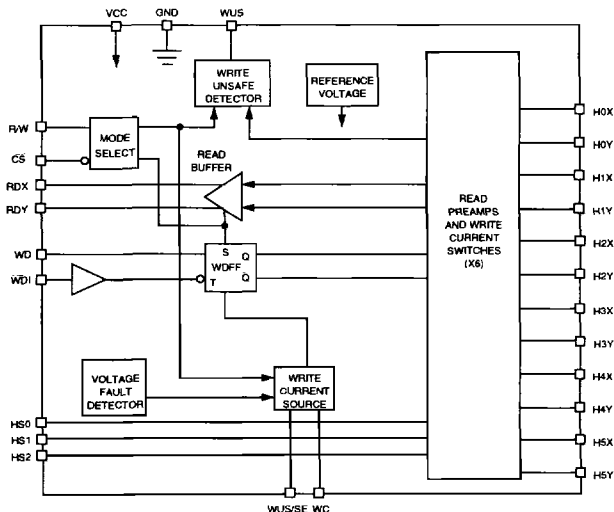

PIN DIAGRAM

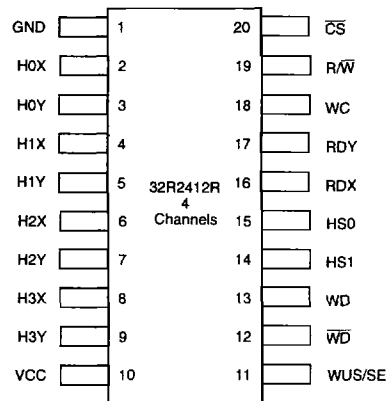

24, 20-Lead SOV, SOL

CAUTION: Use handling procedures necessary for a static sensitive component.

Target Specification: The target specification is intended as an initial disclosure of specification goals for the product. The specifications are based on design goals, subject to change and are not guaranteed. Silicon Systems assumes no obligation regarding future manufacture unless agreed to in writing.

No responsibility is assumed by Silicon Systems for use of this product nor for any infringements of patents and trademarks or other rights of third parties resulting from its use. No license is granted under any patents, patent rights or trademarks of Silicon Systems. Silicon Systems reserves the right to make changes in specifications at any time without notice. Accordingly, the reader is cautioned to verify that the data sheet is current before placing orders.

Silicon Systems, Inc., 14351 Myford Road, Tustin, CA 92680-7022 (714) 573-6000, FAX (714) 573-6914