

52149/52174

79HG REPLACEMENT

**NEGATIVE ADJUSTABLE 5-AMP
VOLTAGE REGULATOR**

Mii

HYBRID MICROELECTRONICS
PRODUCTS DIVISION

Features:

- Replacement for 79HG
- 5.0A Output Current
- Internal Current And Thermal Overload Protection
- Internal Short Circuit Current Limit
- Low Drop-Out Voltage (Typically -2.2 V @ 5.0 A)
- 50W Power Dissipation
- Electrically Isolated Case
- Steel TO-3 Case

Applications:

- Designed for use in general purpose applications where adjustability is advantageous.
- Military and Hi Rel Industrial applications where hermeticity is required.

ORDER INFORMATION

52149	Standard
52174	MIL-STD-883 Screened

DESCRIPTION

The 52149/52174, which is a replacement for the 79HG, is an adjustable 4-terminal voltage regulator capable of supplying in excess of 5 A over a -24 V to -2.55 V output range. This Hybrid Voltage Regulator has been designed with all the inherent characteristics of the monolithic 4-terminal regulator; i.e., full thermal overload and short circuit protection. It is packaged in a hermetically sealed 4-pin, TO-3 package providing 50W power dissipation. The regulator consists of a monolithic chip driving a discrete series-pass element and short circuit detection transistors.

ABSOLUTE MAXIMUM RATINGS

Input Voltage.....	-35 V
Internal Power Dissipation @T _c = 25°C.....	50W
Maximum Input-to-Output Voltage Differential.....	35 V
Operating Junction Temperature	150°C
Storage Temperature Range.....	-55°C to +150°C
Pin Temperature (Soldering, 60 seconds).....	300°C
Commercial Temperature Range 52149	0°C to +125°C
Military Temperature Range 52174.....	-55°C to +125°C

Micropac Industries cannot assume any responsibility for any circuits shown or represent that they are free from patent infringement.
Micropac reserves the right to make changes at any time in order to improve design and to supply the best product possible.

NEGATIVE ADJUSTABLE 5-AMP, VOLTAGE REGULATOR**ELECTRICAL CHARACTERISTICS**

$T_J = 25^\circ\text{C}$, $V_{IN} = -10\text{V}$ and $I_{OUT} = -2.0\text{A}$ unless otherwise specified

PARAMETER	TEST CONDITIONS	MIN	TYP	MAX	UNIT
Output Voltage Range		-7.0		-35	V
Nominal Output Voltage Range	$V_{IN} = V_{OUT} - 5\text{V}$	2.55		24	V
Output Voltage Tolerance	$40\text{V} \leq V_{IN} \leq -7\text{V}$			4	% (V_{OUT})
Line Regulation	$40\text{V} \leq V_{IN} \leq -7\text{V}$		0.4	1.0	% (V_{OUT})
Load Regulation	$V_{IN} = V_{OUT} - 10\text{V}$ $-10\text{mA} \leq I_{OUT} \leq -5.0\text{A}$		0.7	1.0	% (V_{OUT})
Control Pin Current				3.0	μA
Quiescent Current	$V_{IN} = -10\text{V}$			7.0	mA
Ripple Rejection	$-18\text{V} \leq V_{IN} \leq -8.5\text{V}$ $V_{OUT} = -5\text{V}$, $f = 120\text{ Hz}$		50		dB
Output Noise Voltage	$V_{OUT} = -5\text{V}$, $10\text{ Hz} \leq f \leq 100\text{kHz}$		200		μV
Dropout Voltage	$I_{OUT} = -5\text{A} @ -0.95 V_{OUT}$		-2.2		V
Short-Circuit Current Limit	$V_{IN} = -15\text{V}$		8	12	A
Control Pin voltage (Reference)	$V_{IN} = -10\text{V}$	-2.65		-2.45	V

DESIGN CONSIDERATIONS

This device has thermal overload protection from excessive power and internal short circuit protection, which limits the circuit's maximum current. Thus, the device is protected from overload abnormalities. Although the internal power dissipation is limited, the junction temperature must be kept below the maximum specified temperature (150°C). It is recommended, by the manufacturer, that the maximum junction temperature be kept as low as possible for increased reliability. To calculate the maximum junction temperature or heat sink required, the following thermal resistance values should be used.

Package	θ_{JC}	
	Typical	Max
TO-3	1.8	2.5

Where: T_J = Junction Temperature
 T_A = Ambient Temperature
 P_D = Power Dissipation θ_{CS} = Case-to-heat sink thermal resistance
 θ_{JC} = Junction-to-case thermal resistance

$$P_{D(\text{MAX})} = \frac{T_{J(\text{MAX})} - T_A}{\theta_{JC} + \theta_{CA}} \quad \theta_{CA} = \theta_{CS} + \theta_{SA}$$

$$\text{Solving for } T_J = T_A + P_D (\theta_{JC} + \theta_{CA})$$

θ_{CA} = Case-to-ambient thermal resistance

θ_{SA} = Heat sink-to-ambient thermal resistance

The device is designed to operate without external compensation components. However, the amount of external filtering of these voltage regulators depends upon the circuit layout. If in a specific application the regulator is more than four inches from the filter capacitor, a $2\mu\text{F}$ solid tantalum capacitor should be used at the input. A $1\mu\text{F}$ capacitor should be used at the output to reduce transients created by fast switching loads, as seen in the basic test circuit. These filter capacitors must be located as close to the regulator as possible.

Caution: Permanent damage can result from forcing the output voltage higher than the input voltage. A protection diode from output to input should be used if this condition exists.

VOLTAGE OUTPUT

The device has an adjustable output voltage from -2.55 to -24V which can be programmed by the external resistor network (potentiometer or two fixed resistors) using the relationship:

$$V_{OUT} = V_{CONTROL} \frac{R1 + R2}{R2}$$

Example: If $R1 = 0\Omega$ and $R2 = 5\text{k}\Omega$, Then
 $V_{OUT} = -2.55\text{ V}$ nominal,
 or, if $R1 = 12.8\text{ k}\Omega$ and $R2 = 2.1\text{ k}\Omega$ then
 $V_{OUT} = -18\text{V}$.

Micropac Industries cannot assume any responsibility for any circuits shown or represent that they are free from patent infringement. **Micropac** reserves the right to make changes at any time in order to improve design and to supply the best product possible.

NEGATIVE ADJUSTABLE 5-AMP, VOLTAGE REGULATOR

Mechanical Configuration

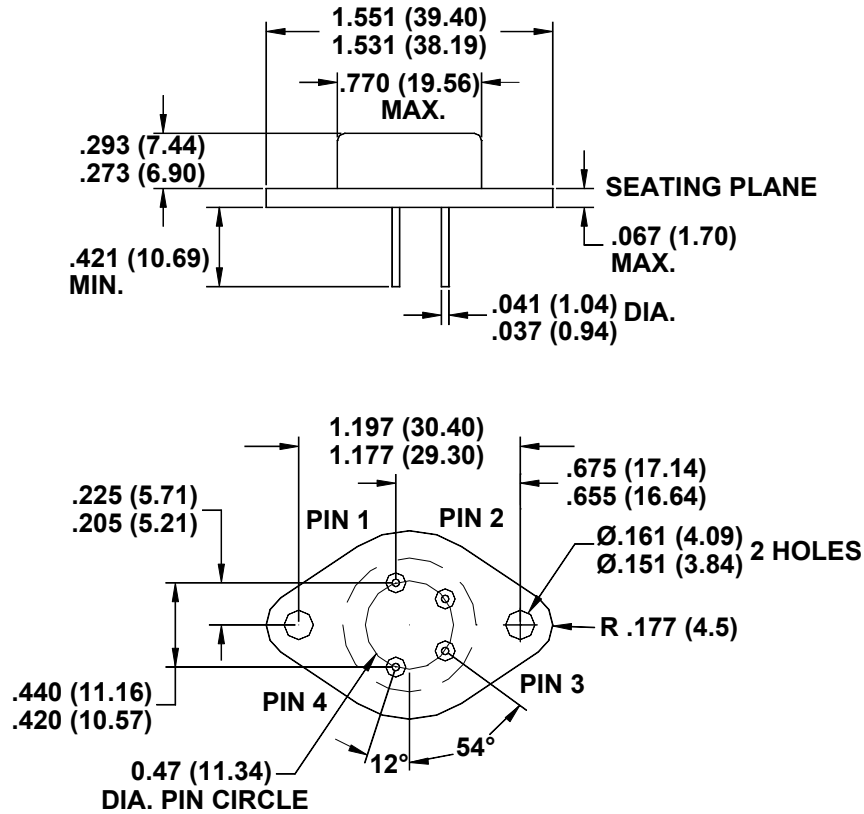

Basic Test Circuit Adjustable Output Voltage

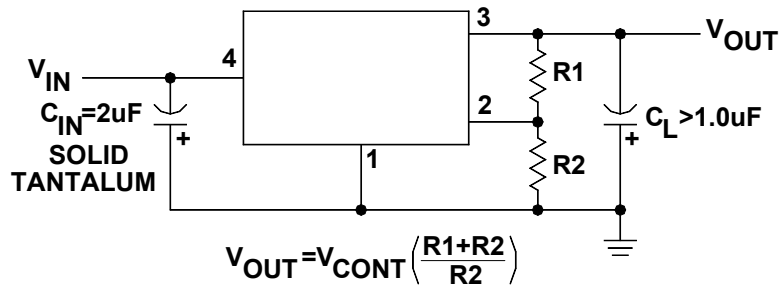

Note: All Dimension in notes and Millimeters (parenthesis)

Micropac Industries cannot assume any responsibility for any circuits shown or represent that they are free from patent infringement. Micropac reserves the right to make changes at any time in order to improve design and to supply the best product possible.