



**Cascadeable 512 x 9 FIFO**  
**Cascadeable 1K x 9 FIFO**  
**Cascadeable 2K x 9 FIFO**

**Features**

- 512 x 9, 1,024 x 9, 2,048 x 9 FIFO buffer memory
- Dual-port RAM cell
- Asynchronous read/write
- High-speed 33.3-MHz read/write independent of depth/width
- Low operating power
  - $I_{CC}(\text{max.}) = 142 \text{ mA}$  (commercial)
  - $I_{CC}(\text{max.}) = 147 \text{ mA}$  (military)
- Half Full flag in standalone
- Empty and Full flags
- Retransmit in standalone
- Expandable in width and depth
- Parallel cascade minimizes bubble-through
- $5V \pm 10\%$  supply
- 300-mil DIP packaging
- 300-mil SOJ packaging

- TTL compatible
- Three-state outputs
- Pin compatible and functional equivalent to IDT7201, IDT7202, and IDT7203

**Functional Description**

The CY7C420/CY7C421, CY7C424/CY7C425, and CY7C428/CY7C429 are first-in-first-out (FIFO) memories offered in 600-mil wide and 300-mil wide packages. They are, respectively, 512, 1,024, and 2,048 words by 9-bits wide. Each FIFO memory is organized such that the data is read in the same sequential order that it was written. Full and Empty flags are provided to prevent overrun and underrun. Three additional pins are also provided to facilitate unlimited expansion in width, depth, or both. The depth expansion technique steers the control signals from one device to another in parallel, thus eliminating the serial addition of propagation delays, so that throughput is not reduced. Data is steered in a similar manner.

The read and write operations may be asynchronous; each can occur at a rate of

33.3 MHz. The write operation occurs when the write ( $\bar{W}$ ) signal is LOW. Read occurs when read ( $\bar{R}$ ) goes LOW. The nine data outputs go to the high-impedance state when  $\bar{R}$  is HIGH.

A Half Full ( $\bar{HF}$ ) output flag is provided that is valid in the standalone and width expansion configurations. In the depth expansion configuration, this pin provides the expansion out ( $\bar{XO}$ ) information that is used to tell the next FIFO that it will be activated.

In the standalone and width expansion configurations, a LOW on the retransmit ( $\bar{RT}$ ) input causes the FIFOs to retransmit the data. Read enable ( $\bar{R}$ ) and write enable ( $\bar{W}$ ) must both be HIGH during retransmit, and then  $\bar{R}$  is used to access the data.

The CY7C420, CY7C421, CY7C424, CY7C425, CY7C428, and CY7C429 are fabricated using an advanced 0.8-micron N-well CMOS technology. Input ESD protection is greater than 2000V and latch-up is prevented by careful layout, guard rings, and a substrate bias generator.

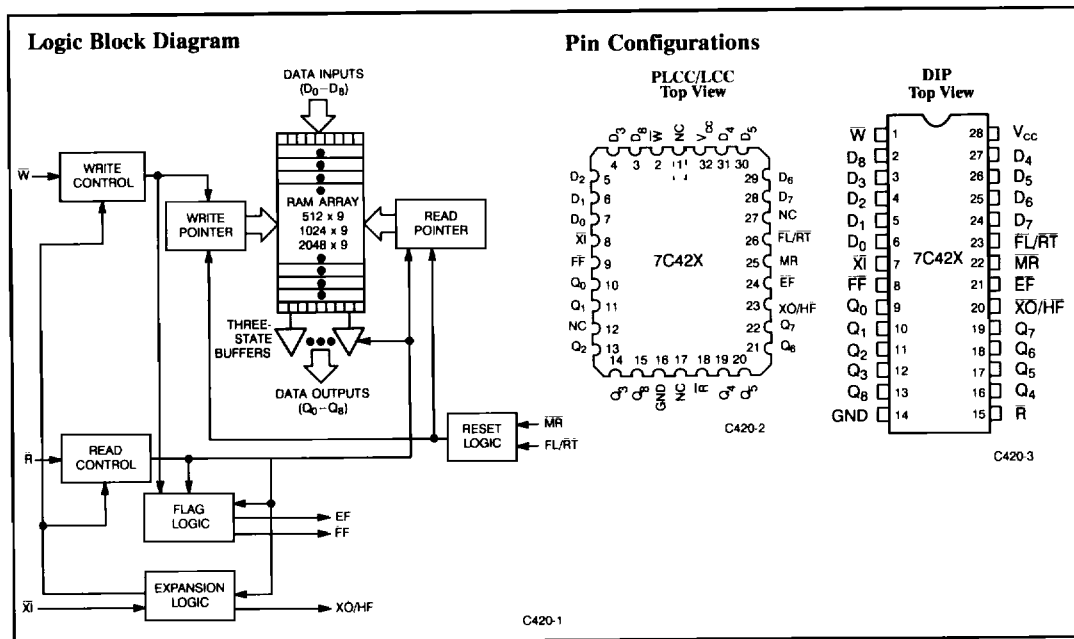



**Selection Guide**

		<b>7C420-20</b> 7C421-20 7C424-20 7C425-20 7C428-20 7C429-20	<b>7C420-25</b> 7C421-25 7C424-25 7C425-25 7C428-25 7C429-25	<b>7C420-30</b> 7C421-30 7C424-30 7C425-30 7C428-30 7C429-30	<b>7C420-40</b> 7C421-40 7C424-40 7C425-40 7C428-40 7C429-40	<b>7C420-65</b> 7C421-65 7C424-65 7C425-65 7C428-65 7C429-65
Frequency (MHz)		33.3	28.5	25	20	12.5
Maximum Access Time (ns)		20	25	30	40	65
Maximum Operating Current (mA)	Commercial	142	132	125	115	100
	Military/Industrial		147	140	130	115

**Maximum Rating**

(Above which the useful life may be impaired. For user guidelines, not tested.)

- Storage Temperature ..... - 65°C to +150°C
- Ambient Temperature with Power Applied ..... - 55°C to +125°C
- Supply Voltage to Ground Potential ..... - 0.5V to +7.0V
- DC Voltage Applied to Outputs in High Z State ..... - 0.5V to +7.0V
- DC Input Voltage ..... - 3.0V to +7.0V
- Power Dissipation ..... 1.0W
- Output Current, into Outputs (LOW) ..... 20 mA

Static Discharge Voltage ..... >2001V (per MIL-STD-883, Method 3015)

Latch-Up Current ..... >200 mA

**Operating Range**

Range	Ambient Temperature <sup>[1]</sup>	V <sub>CC</sub>
Commercial	0°C to +70°C	5V ± 10%
Industrial	- 40°C to +85°C	5V ± 10%
Military	- 55°C to +125°C	5V ± 10%

**Electrical Characteristics** Over the Operating Range<sup>[2]</sup>

Parameter	Description	Test Conditions	7C420-20 7C421-20 7C424-20 7C425-20 7C428-20 7C429-20		7C420-25 7C421-25 7C424-25 7C425-25 7C428-25 7C429-25		7C420-30 7C421-30 7C424-30 7C425-30 7C428-30 7C429-30		Units	
			Min.	Max.	Min.	Max.	Min.	Max.		
V <sub>OH</sub>	Output HIGH Voltage	V <sub>CC</sub> = Min., I <sub>OH</sub> = - 2.0 mA	2.4		2.4		2.4		V	
V <sub>OL</sub>	Output LOW Voltage	V <sub>CC</sub> = Min., I <sub>OL</sub> = 8.0 mA		0.4		0.4		0.4	V	
V <sub>IH</sub>	Input HIGH Voltage		Com'l	2.0	V <sub>CC</sub>	2.0	V <sub>CC</sub>	2.0	V <sub>CC</sub>	V
			Mil/Ind			2.2	V <sub>CC</sub>	2.2	V <sub>CC</sub>	V
V <sub>IL</sub>	Input LOW Voltage		- 3.0	0.8	- 3.0	0.8	- 3.0	0.8	V	
I <sub>IX</sub>	Input Leakage Current	GND ≤ V <sub>I</sub> ≤ V <sub>CC</sub>	- 10	+10	- 10	+10	- 10	+10	µA	
I <sub>OZ</sub>	Output Leakage Current	$\bar{R} \geq V_{IH}$ , GND ≤ V <sub>O</sub> ≤ V <sub>CC</sub>	- 10	+10	- 10	+10	- 10	+10	µA	
I <sub>CC</sub>	Operating Current	V <sub>CC</sub> = Max., I <sub>OUT</sub> = 0 mA	Com'l <sup>[3]</sup>	142		132		125	mA	
			Mil/Ind <sup>[4]</sup>			147		140		
I <sub>SB1</sub>	Standby Current	All Inputs = V <sub>IH</sub> Min.	Com'l	30		25		25	mA	
			Mil/Ind			30		30		
I <sub>SB2</sub>	Power-Down Current	All Inputs ≥ V <sub>CC</sub> - 0.2V	Com'l	25		20		20	mA	
			Mil/Ind			25		25		
I <sub>OS</sub>	Output Short Circuit Current <sup>[5]</sup>	V <sub>CC</sub> = Max., V <sub>OUT</sub> = GND		- 90		- 90		- 90	mA	

**Notes:**

1. T<sub>A</sub> is the "instant on" case temperature.
2. See the last page of this specification for Group A subgroup testing information.
3. I<sub>CC</sub> (commercial) = 100 mA + [(f - 12.5) \* 2 mA/MHz] for f ≥ 12.5 MHz where f = the larger of the write or read operating frequency.
4. I<sub>CC</sub> (military) = 115 mA + [(f̄ - 12.5) \* 2 mA/MHz] for f̄ ≥ 12.5 MHz where f̄ = the larger of the write or read operating frequency.
5. For test purposes, not more than one output at a time should be shorted. Short circuit test duration should not exceed 30 seconds.

**Electrical Characteristics** Over the Operating Range<sup>[2]</sup> (continued)

Parameter	Description	Test Conditions	7C420-40 7C421-40 7C424-40 7C425-40 7C428-40 7C429-40		7C420-65 7C421-65 7C424-65 7C425-65 7C428-65 7C429-65		Units	
			Min.	Max.	Min.	Max.		
V <sub>OH</sub>	Output HIGH Voltage	V <sub>CC</sub> = Min., I <sub>OH</sub> = - 2.0 mA	2.4		2.4		V	
V <sub>OL</sub>	Output LOW Voltage	V <sub>CC</sub> = Min., I <sub>OL</sub> = 8.0 mA		0.4		0.4	V	
V <sub>IH</sub>	Input HIGH Voltage		Com'l	2.0	V <sub>CC</sub>	2.0	V <sub>CC</sub>	V
			Mil/Ind	2.2	V <sub>CC</sub>	2.2	V <sub>CC</sub>	
V <sub>IL</sub>	Input LOW Voltage		- 3.0	0.8	- 3.0	0.8	V	
I <sub>IX</sub>	Input Leakage Current	GND ≤ V <sub>I</sub> ≤ V <sub>CC</sub>	- 10	+10	- 10	+10	μA	
I <sub>OZ</sub>	Output Leakage Current	$\bar{R} \geq V_{IH}$ , GND ≤ V <sub>O</sub> ≤ V <sub>CC</sub>	- 10	+10	- 10	+10	μA	
I <sub>CC</sub>	Operating Current	V <sub>CC</sub> = Max., I <sub>OUT</sub> = 0 mA	Com'l <sup>[3]</sup>		115		100	mA
			Mil/Ind <sup>[4]</sup>		130		115	
I <sub>SB1</sub>	Standby Current	All Inputs = V <sub>IH</sub> Min.	Com'l		25		25	mA
			Mil		30		30	
I <sub>SB2</sub>	Power-Down Current	All Inputs ≥ V <sub>CC</sub> - 0.2V	Com'l		20		20	mA
			Mil		25		25	
I <sub>OS</sub>	Output Short Circuit Current <sup>[5]</sup>	V <sub>CC</sub> = Max., V <sub>OUT</sub> = GND		- 90		- 90	mA	

**Capacitance<sup>[6]</sup>**

Parameters	Description	Test Conditions	Max.	Units
C <sub>IN</sub>	Input Capacitance	T <sub>A</sub> = 25°C, f = 1 MHz,	8	pF
C <sub>OUT</sub>	Output Capacitance	V <sub>CC</sub> = 4.5V	10	pF

**Notes:**

6. Tested initially and after any design or process changes that may affect these parameters.

**AC Test Loads and Waveforms**

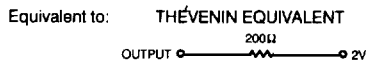
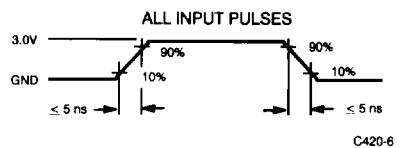
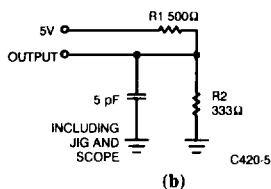
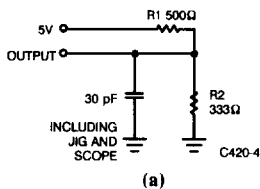

Switching Characteristics Over the Operating Range<sup>[7,8]</sup>

Parameters	Description	7C420-20		7C420-25		7C420-30		7C420-40		7C420-65		Units
		Min.	Max.	Min.	Max.	Min.	Max.	Min.	Max.	Min.	Max.	
t <sub>RC</sub>	Read Cycle Time	30		35		40		50		80		ns
t <sub>A</sub>	Access Time		20		25		30		40		65	ns
t <sub>RR</sub>	Read Recovery Time	10		10		10		10		15		ns
t <sub>PR</sub>	Read Pulse Width	20		25		30		40		65		ns
t <sub>LZR</sub> <sup>[9]</sup>	Read LOW to Low Z	3		3		3		3		3		ns
t <sub>DVR</sub> <sup>[9,10]</sup>	Read HIGH to Data Valid	3		3		3		3		3		ns
t <sub>HZR</sub> <sup>[9,10]</sup>	Read HIGH to High Z		15		18		20		25		30	ns
t <sub>WC</sub>	Write Cycle Time	30		35		40		50		80		ns
t <sub>PW</sub>	Write Pulse Width	20		25		30		40		65		ns
t <sub>HWZ</sub> <sup>[9]</sup>	Write HIGH to Low Z	10		10		10		10		10		ns
t <sub>WR</sub>	Write Recovery Time	10		10		10		10		15		ns
t <sub>SD</sub>	Data Set-Up Time	12		15		18		20		30		ns
t <sub>HD</sub>	Data Hold Time	0		0		0		0		10		ns
t <sub>MRSC</sub>	MR Cycle Time	30		35		40		50		80		ns
t <sub>PMR</sub>	MR Pulse Width	20		25		30		40		65		ns
t <sub>RMR</sub>	MR Recovery Time	10		10		10		10		15		ns
t <sub>RPW</sub>	Read HIGH to MR HIGH	20		25		30		40		65		ns
t <sub>WPW</sub>	Write HIGH to MR HIGH	20		25		30		40		65		ns
t <sub>RTC</sub>	Retransmit Cycle Time	30		35		40		50		80		ns
t <sub>PRT</sub>	Retransmit Pulse Width	20		25		30		40		65		ns
t <sub>RTR</sub>	Retransmit Recovery Time	10		10		10		10		15		ns
t <sub>EFL</sub>	MR to EF LOW		30		35		40		50		80	ns
t <sub>HFH</sub>	MR to HF HIGH		30		35		40		50		80	ns
t <sub>FFH</sub>	MR to FF HIGH		30		35		40		50		80	ns
t <sub>REF</sub>	Read LOW to EF LOW		25		25		30		35		60	ns
t <sub>RFF</sub>	Read HIGH to FF HIGH		25		25		30		35		60	ns
t <sub>WEF</sub>	Write HIGH to EF HIGH		25		25		30		35		60	ns
t <sub>WFF</sub>	Write LOW to FF LOW		25		25		30		35		60	ns
t <sub>WHF</sub>	Write LOW to HF LOW		30		35		40		50		80	ns
t <sub>RHF</sub>	Read HIGH to HF HIGH		30		35		40		50		80	ns
t <sub>RAE</sub>	Effective Read from Write HIGH		20		25		30		35		60	ns
t <sub>RPE</sub>	Effective Read Pulse Width After EF HIGH	20		25		30		40		65		ns
t <sub>WAF</sub>	Effective Write from Read HIGH		20		25		30		35		60	ns
t <sub>WPF</sub>	Effective Write Pulse Width After FF HIGH	20		25		30		40		65		ns
t <sub>XOL</sub>	Expansion Out LOW Delay from Clock		20		25		30		40		65	ns
t <sub>XOH</sub>	Expansion Out HIGH Delay from Clock		20		25		30		40		65	ns

## Switching Waveforms

### Asynchronous Read and Write

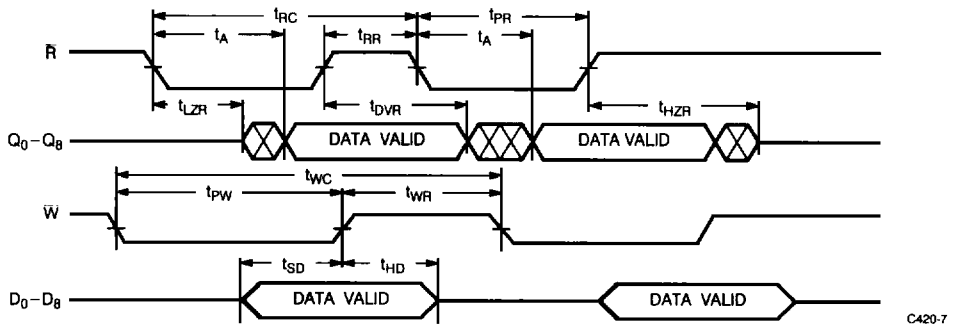

### Master Reset

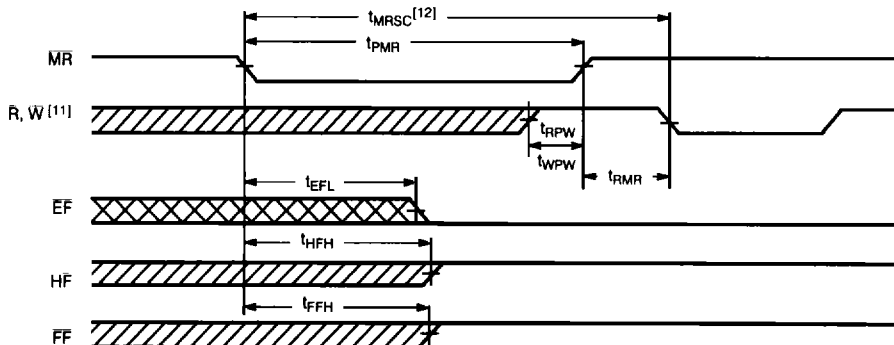

### Half-Full Flag

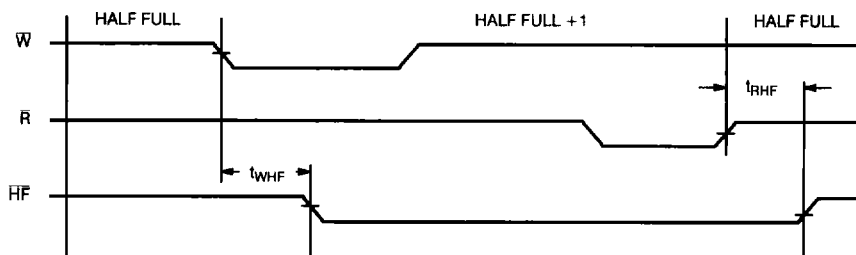

#### Notes:

7. Test conditions assume signal transition time of 5 ns or less, timing reference levels of 1.5V and output loading of the specified  $I_{OL}/I_{OH}$  and 30 pF load capacitance, as in part (a) of AC Test Load and Waveforms, unless otherwise specified.
8. See the last page of this specification for Group A subgroup testing information.
9.  $t_{HZR}$  transition is measured at +500 mV from  $V_{OL}$  and -500 mV from  $V_{OH}$ .  $t_{DVR}$  transition is measured at the 1.5V level.  $t_{HWZ}$  and  $t_{LZR}$  transition is measured at  $\pm 100$  mV from the steady state.
10.  $t_{HZR}$  and  $t_{DVR}$  use capacitance loading as in part (b) of AC Test Load and Waveforms.
11.  $\bar{W}$  and  $R > V_{IH}$  around the rising edge of  $\bar{MR}$ .
12.  $t_{MRSC} = t_{PMR} + t_{RMR}$ .

Switching Waveforms (continued)

Last Write to First Read Full Flag

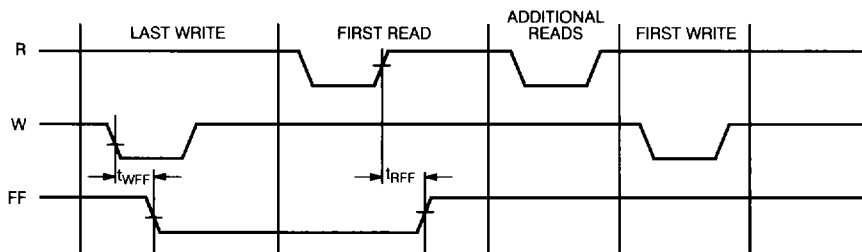

C420-10

Last Read to First Write Empty Flag

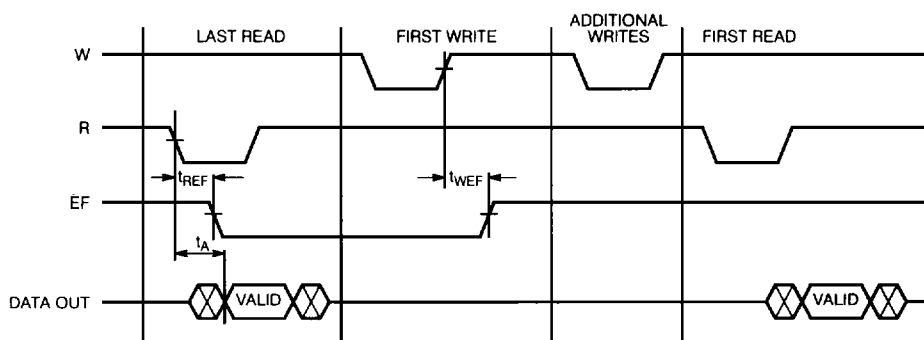

C420-11

Retransmit<sup>13]</sup>

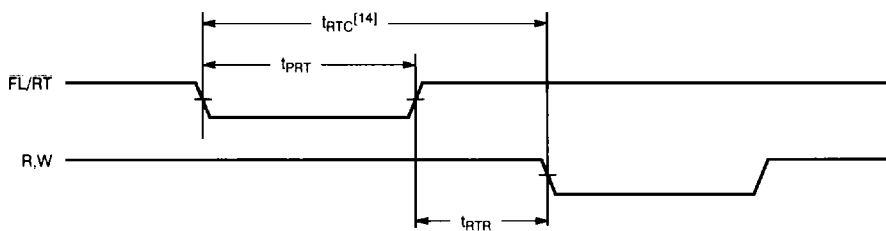

C420-12

Notes:

13. EF, HF and FF may change state during retransmit as a result of the offset of the read and write pointers, but flags will be valid at  $t_{RTC}$ .
14.  $t_{RTC} = t_{PRT} + t_{RTR}$ .

Switching Waveforms (continued)

Empty Flag and Empty Boundary Timing Diagram

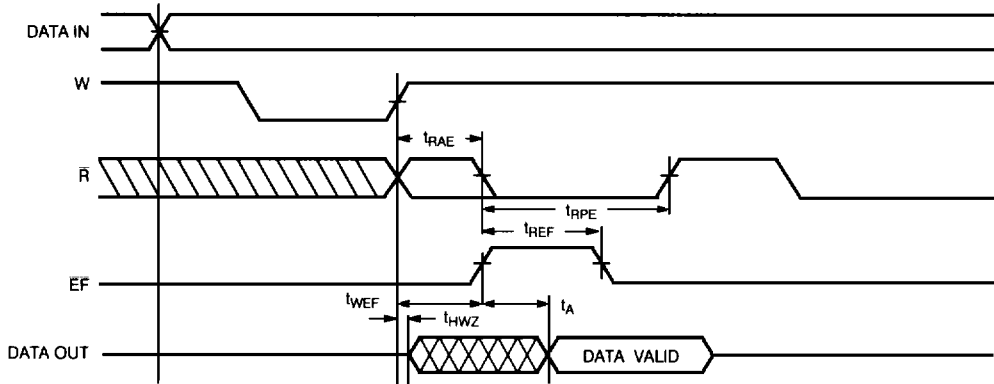

C420-13

Full Flag and Full Boundary Timing Diagram

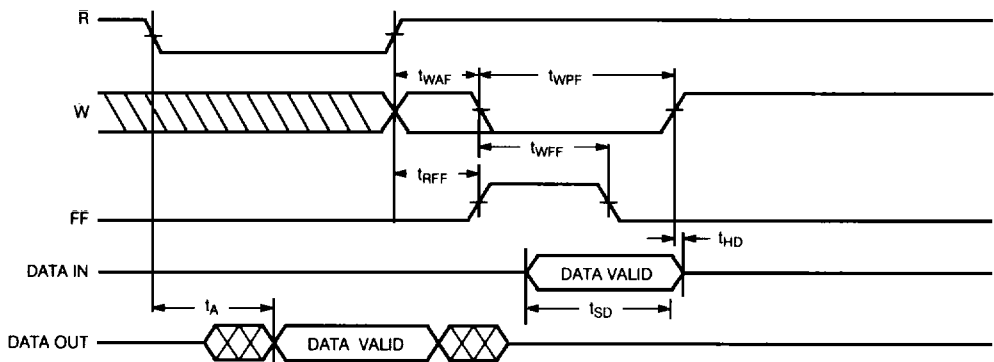

C420-14

Switching Waveforms (continued)

Expansion Timing Diagrams

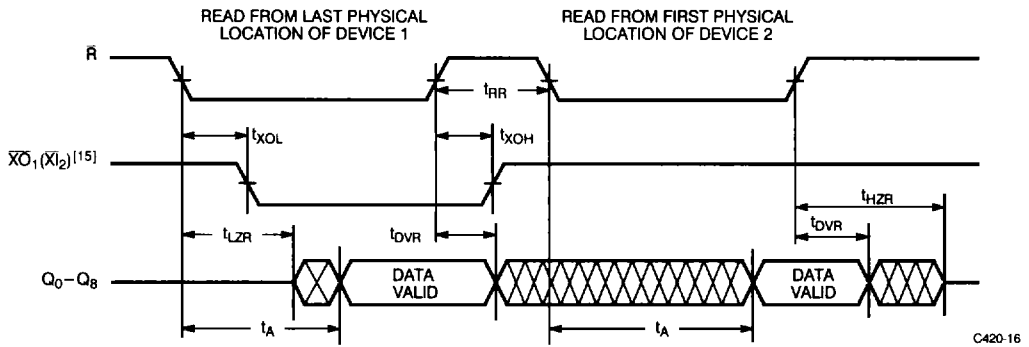
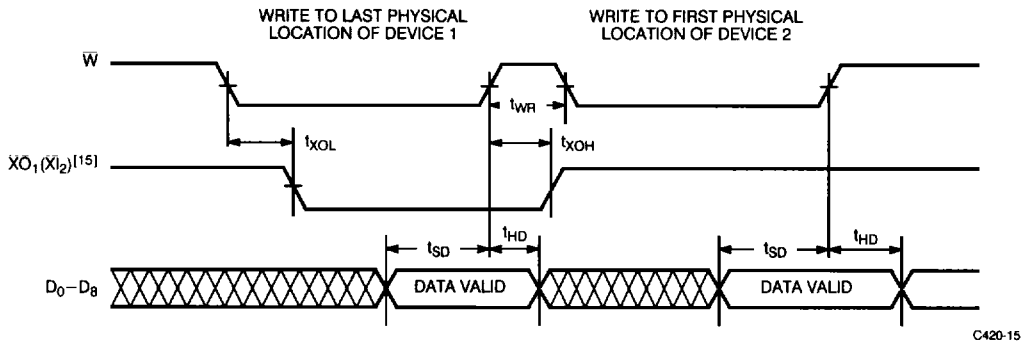

Notes:

15. Expansion Out of device 1 ( $\overline{XO}_1$ ) is connected to Expansion In of device 2 ( $\overline{XI}_2$ ).





## Architecture

The CY7C420/421/424/425/428/429 FIFOs consist of an array of 512/1024/2048 words of 9 bits each (implemented by an array of dual-port RAM cells), a read pointer, a write pointer, control signals ( $\bar{W}$ ,  $\bar{R}$ ,  $\bar{XI}$ ,  $\bar{XO}$ ,  $\bar{FL}$ ,  $\bar{RT}$ ,  $\bar{MR}$ ), and Full, Half Full, and Empty flags.

### Dual-Port RAM

The dual-port RAM architecture refers to the basic memory cell used in the RAM. The cell itself enables the read and write operations to be independent of each other, which is necessary to achieve truly asynchronous operation of the inputs and outputs. A second benefit is that the time required to increment the read and write pointers is much less than the time that would be required for data propagation through the memory, which would be the case if the memory were implemented using the conventional register array architecture.

### Resetting the FIFO

Upon power-up, the FIFO must be reset with a Master Reset ( $\bar{MR}$ ) cycle. This causes the FIFO to enter the empty condition signified by the Empty flag ( $\bar{EF}$ ) being LOW, and both the Half Full ( $\bar{HF}$ ) and Full flags ( $\bar{FF}$ ) being HIGH. Read ( $\bar{R}$ ) and write ( $\bar{W}$ ) must be HIGH  $t_{RPW}/t_{WPW}$  before and  $t_{RMR}$  after the rising edge of  $\bar{MR}$  for a valid reset cycle. If reading from the FIFO after a reset cycle is attempted, the outputs will all be in the high-impedance state.

### Writing Data to the FIFO

The availability of at least one empty location is indicated by a HIGH  $\bar{FF}$ . The falling edge of  $\bar{W}$  initiates a write cycle. Data appearing at the inputs ( $D_0 - D_8$ )  $t_{SD}$  before and  $t_{HD}$  after the rising edge of  $\bar{W}$  will be stored sequentially in the FIFO.

The  $\bar{EF}$  LOW-to-HIGH transition occurs  $t_{WEF}$  after the first LOW-to-HIGH transition of  $\bar{W}$  for an empty FIFO.  $\bar{HF}$  goes LOW  $t_{WHF}$  after the falling edge of  $\bar{W}$  following the FIFO actually being Half Full. Therefore, the  $\bar{HF}$  is active once the FIFO is filled to half its capacity plus one word.  $\bar{HF}$  will remain LOW while less than one half of total memory is available for writing. The LOW-to-HIGH transition of  $\bar{HF}$  occurs  $t_{RHF}$  after the rising edge of  $\bar{R}$  when the FIFO goes from half full +1 to half full.  $\bar{HF}$  is available in standalone and width expansion modes.  $\bar{FF}$  goes LOW  $t_{WFF}$  after the falling edge of  $\bar{W}$ , during the cycle in which the last available location is filled. Internal logic prevents over-running a full FIFO. Writes to a full FIFO are ignored and the write pointer is not incremented.  $\bar{FF}$  goes HIGH  $t_{REF}$  after a read from a full FIFO.

### Reading Data from the FIFO

The falling edge of  $\bar{R}$  initiates a read cycle if the  $\bar{EF}$  is not LOW. Data outputs ( $Q_0 - Q_8$ ) are in a high-impedance condition between read operations ( $\bar{R}$  HIGH) when the FIFO is empty, or

when the FIFO is not the active device in the depth expansion mode.

When one word is in the FIFO, the falling edge of  $\bar{R}$  initiates a HIGH-to-LOW transition of  $\bar{EF}$ . When the FIFO is empty, the outputs are in a high-impedance state. Reads to an empty FIFO are ignored and do not increment the read pointer. From the empty condition, the FIFO can be read  $t_{WRF}$  after a valid write.

### Retransmit

The retransmit feature is beneficial when transferring packets of data. It enables the receipt of data to be acknowledged by the receiver and retransmitted if necessary.

The Retransmit ( $\bar{RT}$ ) input is active in the standalone and width expansion modes. The retransmit feature is intended for use when a number of writes equal to or less than the depth of the FIFO have occurred since the last  $\bar{MR}$  cycle. A LOW pulse on  $\bar{RT}$  resets the internal read pointer to the first physical location of the FIFO.  $\bar{R}$  and  $\bar{W}$  must both be HIGH while and  $t_{RTR}$  after retransmit is LOW. With every read cycle after retransmit, previously accessed data is read and the read pointer is incremented until it is equal to the write pointer. Full, Half Full, and Empty flags are governed by the relative locations of the read and write pointers and are updated during a retransmit cycle. Data written to the FIFO after activation of  $\bar{RT}$  are transmitted also.

The full depth of the FIFO can be repeatedly transmitted.

### Standalone/Width Expansion Modes

Standalone and width expansion modes are set by grounding Expansion In ( $\bar{XI}$ ) and tying First Load ( $\bar{FL}$ ) to  $V_{CC}$ . FIFOs can be expanded in width to provide word widths greater than nine in increments of nine. During width expansion mode, all control line inputs are common to all devices, and flag outputs from any device can be monitored.

### Depth Expansion Mode (see Figure 1)

Depth expansion mode is entered when, during a  $\bar{MR}$  cycle, Expansion Out ( $\bar{XO}$ ) of one device is connected to Expansion In ( $\bar{XI}$ ) of the next device, with  $\bar{XO}$  of the last device connected to  $\bar{XI}$  of the first device. In the depth expansion mode the First Load ( $\bar{FL}$ ) input, when grounded, indicates that this part is the first to be loaded. All other devices must have this pin HIGH. To enable the correct FIFO,  $\bar{XO}$  is pulsed LOW when the last physical location of the previous FIFO is written to and pulsed LOW again when the last physical location is read. Only one FIFO is enabled for read and one for write at any given time. All other devices are in standby.

FIFOs can also be expanded simultaneously in depth and width. Consequently, any depth or width FIFO can be created of word widths in increments of 9. When expanding in depth, a composite  $\bar{FF}$  must be created by ORing the  $\bar{FF}$ s together. Likewise, a composite  $\bar{EF}$  is created by ORing the  $\bar{EF}$ s together.  $\bar{HF}$  and  $\bar{RT}$  functions are not available in depth expansion mode.

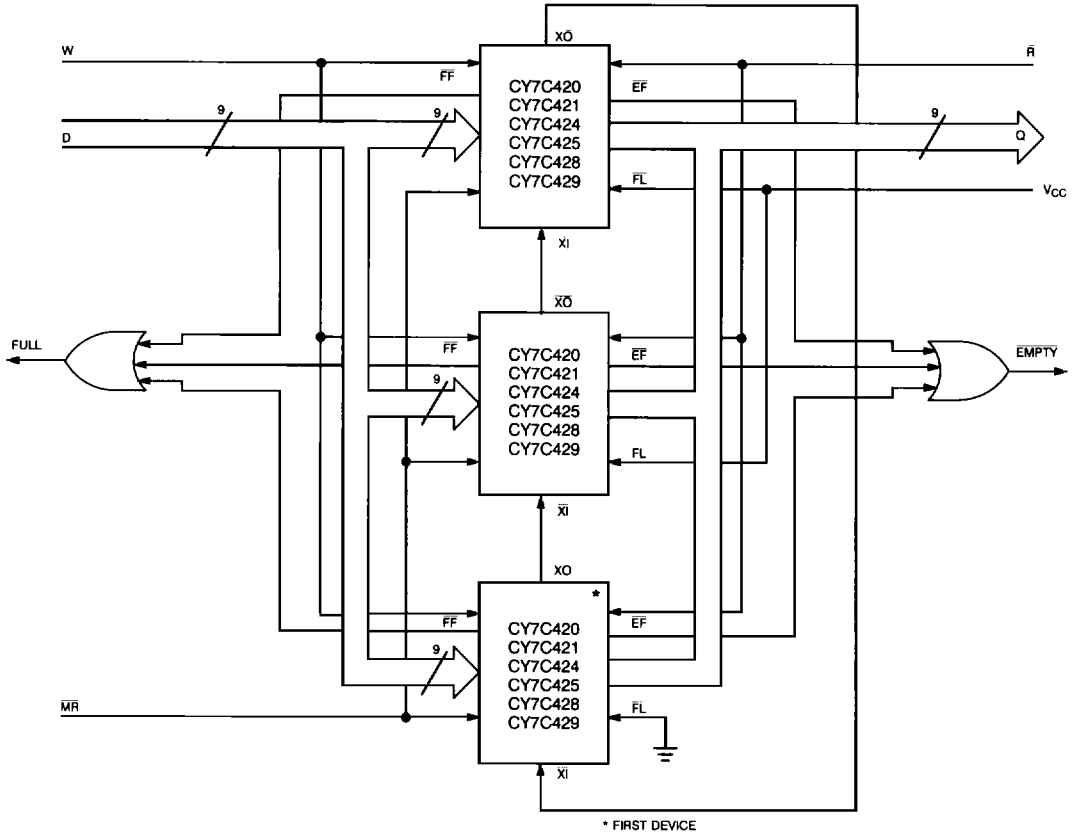
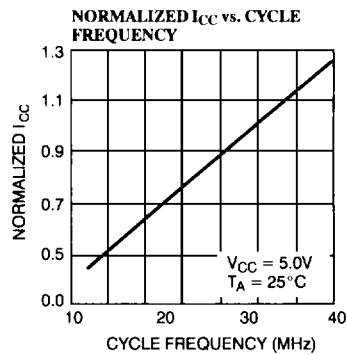
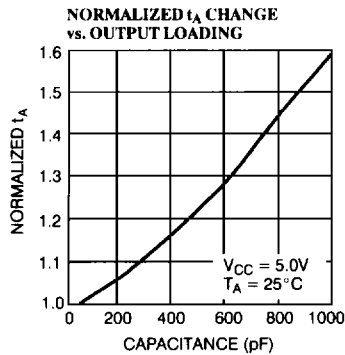
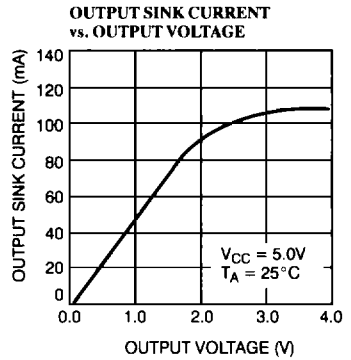
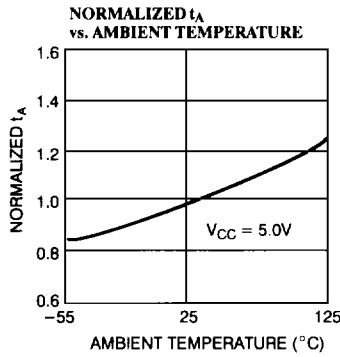
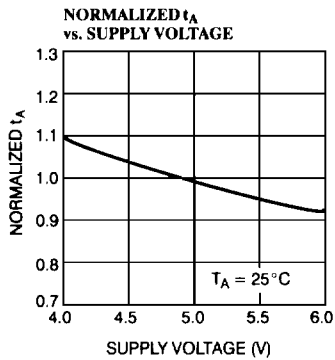
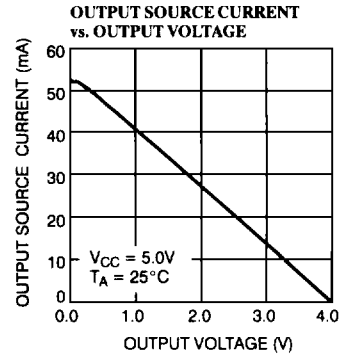
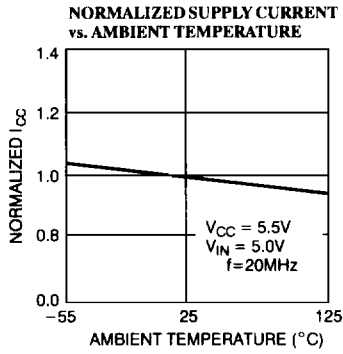
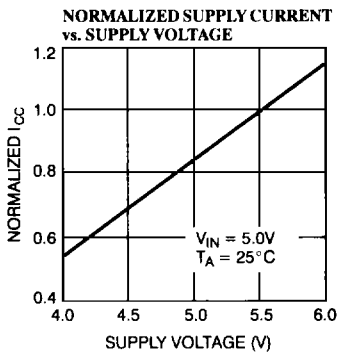

Figure 1. Depth Expansion

C420-17

Typical DC and AC Characteristics





**Ordering Information**

Speed (ns)	Ordering Code	Package Type	Operating Range
20	CY7C420-20DC	D16	Commercial
	CY7C420-20PC	P15	
25	CY7C420-25DC	D16	Commercial
	CY7C420-25PC	P15	
	CY7C420-25DI	D16	Industrial
	CY7C420-25PI	P15	Military
CY7C420-25DMB	D16		
30	CY7C420-30DC	D16	Commercial
	CY7C420-30PC	P15	
	CY7C420-30DI	D16	Industrial
	CY7C420-30PI	P15	Military
	CY7C420-30DMB	D16	
40	CY7C420-40DC	D16	Commercial
	CY7C420-40PC	P15	
	CY7C420-40DI	D16	Industrial
	CY7C420-40PI	P15	Military
	CY7C420-40DMB	D16	
65	CY7C420-65DC	D16	Commercial
	CY7C420-65PC	P15	
	CY7C420-65DI	D16	Industrial
	CY7C420-65PI	P15	Military
	CY7C420-65DMB	D16	

Speed (ns)	Ordering Code	Package Type	Operating Range
20	CY7C421-20DC	D22	Commercial
	CY7C421-20JC	J65	
	CY7C421-20LC	L55	
	CY7C421-20PC	P21	
	CY7C421-20VC	V21	
25	CY7C421-25DC	D22	Commercial
	CY7C421-25JC	J65	
	CY7C421-25LC	L55	
	CY7C421-25PC	P21	
	CY7C421-25VC	V21	
	CY7C421-25DI	D22	Industrial
	CY7C421-25JI	J65	
	CY7C421-25PI	P21	Military
	CY7C421-25DMB	D22	
	CY7C421-25KMB	K74	
CY7C421-25LMB	L55		
30	CY7C421-30DC	D22	Commercial
	CY7C421-30JC	J65	
	CY7C421-30LC	L55	
	CY7C421-30PC	P21	
	CY7C421-30VC	V21	
	CY7C421-30DI	D22	Industrial
	CY7C421-30JI	J65	
	CY7C421-30PI	P21	Military
	CY7C421-30DMB	D22	
	CY7C421-30KMB	K74	
CY7C421-30LMB	L55		
40	CY7C421-40DC	D22	Commercial
	CY7C421-40JC	J65	
	CY7C421-40LC	L55	
	CY7C421-40PC	P21	
	CY7C421-40VC	V21	
	CY7C421-40DI	D22	Industrial
	CY7C421-40JI	J65	
	CY7C421-40PI	P21	Military
	CY7C421-40DMB	D22	
	CY7C421-40KMB	K74	
CY7C421-40LMB	L55		
65	CY7C421-65DC	D22	Commercial
	CY7C421-65JC	J65	
	CY7C421-65LC	L55	
	CY7C421-65PC	P21	
	CY7C421-65VC	V21	
	CY7C421-65DI	D22	Industrial
	CY7C421-65JI	J65	
	CY7C421-65PI	P21	Military
	CY7C421-65DMB	D22	
	CY7C421-65KMB	K74	
CY7C421-65LMB	L55		

**FIFOS 5**



**Ordering Information (continued)**

Speed (ns)	Ordering Code	Package Type	Operating Range
20	CY7C424-20DC	D16	Commercial
	CY7C424-20PC	P15	
25	CY7C424-25DC	D16	Commercial
	CY7C424-25PC	P15	
	CY7C424-25DI	D16	Industrial
	CY7C424-25PI	P15	
	CY7C424-25DMB	D16	
30	CY7C424-30DC	D16	Commercial
	CY7C424-30PC	P15	
	CY7C424-30DI	D16	Industrial
	CY7C424-30PI	P15	
	CY7C424-30DMB	D16	
40	CY7C424-40DC	D16	Commercial
	CY7C424-40PC	P15	
	CY7C424-40DI	D16	Industrial
	CY7C424-40PI	P15	
	CY7C424-40DMB	D16	
65	CY7C424-65DC	D16	Commercial
	CY7C424-65PC	P15	
	CY7C424-65DI	D16	Industrial
	CY7C424-65PI	P15	
	CY7C424-65DMB	D16	

Speed (ns)	Ordering Code	Package Type	Operating Range
20	CY7C425-20DC	D22	Commercial
	CY7C425-20JC	J65	
	CY7C425-20LC	L55	
	CY7C425-20PC	P21	
	CY7C425-20VC	V21	
25	C77C425-25DC	D22	Commercial
	CY7C425-25JC	J65	
	CY7C425-25LC	L55	
	CY7C425-25PC	P21	
	CY7C425-25VC	V21	
	CY7C425-25DI	D22	Industrial
	CY7C425-25JI	J65	
	CY7C425-25PI	P21	Military
	CY7C425-25DMB	D22	
	CY7C425-25KMB	K74	
30	C77C425-30DC	D22	Commercial
	CY7C425-30JC	J65	
	CY7C425-30LC	L55	
	CY7C425-30PC	P21	
	CY7C425-30VC	V21	
	CY7C425-30DI	D22	Industrial
	CY7C425-30JI	J65	
	CY7C425-30PI	P21	Military
	CY7C425-30DMB	D22	
	CY7C425-30KMB	K74	
40	C77C425-40DC	D22	Commercial
	CY7C425-40JC	J65	
	CY7C425-40LC	L55	
	CY7C425-40PC	P21	
	CY7C425-40VC	V21	
	CY7C425-40DI	D22	Industrial
	CY7C425-40JI	J65	
	CY7C425-40PI	P21	Military
	CY7C425-40DMB	D22	
	CY7C425-40KMB	K74	
65	C77C425-65DC	D22	Commercial
	CY7C425-65JC	J65	
	CY7C425-65LC	L55	
	CY7C425-65PC	P21	
	CY7C425-65VC	V21	
	CY7C425-65DI	D22	Industrial
	CY7C425-65JI	J65	
	CY7C425-65PI	P21	Military
	CY7C425-65DMB	D22	
	CY7C425-65KMB	K74	
	CY7C425-65LMB	L55	

**Ordering Information (continued)**

Speed (ns)	Ordering Code	Package Type	Operating Range
20	CY7C428-20DC	D16	Commercial
	CY7C428-20PC	P15	
25	CY7C428-25DC	D16	Commercial
	CY7C428-25PC	P15	
	CY7C428-25DI	D16	Industrial
	CY7C428-25PI	P15	
CY7C428-25DMB	D16	Military	
30	CY7C428-30DC	D16	Commercial
	CY7C428-30PC	P15	
	CY7C428-30DI	D16	Industrial
	CY7C428-30PI	P15	
	CY7C428-30DMB	D16	Military
40	CY7C428-40DC	D16	Commercial
	CY7C428-40PC	P15	
	CY7C428-40DI	D16	Industrial
	CY7C428-40PI	P15	
	CY7C428-40DMB	D16	Military
65	CY7C428-65DC	D16	Commercial
	CY7C428-65PC	P15	
	CY7C428-65DI	D16	Industrial
	CY7C428-65PI	P15	
	CY7C428-65DMB	D16	Military

Speed (ns)	Ordering Code	Package Type	Operating Range	
20	CY7C429-20DC	D22	Commercial	
	CY7C429-20JC	J65		
	CY7C429-20LC	L55		
	CY7C429-20PC	P21		
	CY7C429-20VC	V21		
25	CY7C429-25DC	D22	Commercial	
	CY7C429-25JC	J65		
	CY7C429-25LC	L55		
	CY7C429-25PC	P21		
	CY7C429-25VC	V21		
	CY7C429-25DI	D22	Industrial	
	CY7C429-25JI	J65		
	CY7C429-25PI	P21	Military	
	CY7C429-25DMB	D22		
	CY7C429-25KMB	K74		
CY7C429-25LMB	L55			
30	CY7C429-30DC	D22	Commercial	
	CY7C429-30JC	J65		
	CY7C429-30LC	L55		
	CY7C429-30PC	P21		
	CY7C429-30VC	V21		
	CY7C429-30DI	D22	Industrial	
	CY7C429-30JI	J65		
	CY7C429-30PI	P21	Military	
	CY7C429-30DMB	D22		
	CY7C429-30KMB	K74		
	CY7C429-30LMB	L55		
	40	CY7C429-40DC	D22	Commercial
		CY7C429-40JC	J65	
CY7C429-40LC		L55		
CY7C429-40PC		P21		
CY7C429-40VC		V21		
CY7C429-40DI		D22	Industrial	
CY7C429-40JI		J65		
CY7C429-40PI		P21	Military	
CY7C429-40DMB		D22		
CY7C429-40KMB		K74		
CY7C429-40LMB		L55		
65		CY7C429-65DC	D22	Commercial
	CY7C429-65JC	J65		
	CY7C429-65LC	L55		
	CY7C429-65PC	P21		
	CY7C429-65VC	V21		
	CY7C429-65DI	D22	Industrial	
	CY7C429-65JI	J65		
	CY7C429-65PI	P21	Military	
	CY7C429-65DMB	D22		
	CY7C429-65KMB	K74		
	CY7C429-65LMB	L55		

**MILITARY SPECIFICATIONS**  
**Group A Subgroup Testing**  
**DC Characteristics**

Parameters	Subgroups
V <sub>OH</sub>	1, 2, 3
V <sub>OL</sub>	1, 2, 3
V <sub>IH</sub>	1, 2, 3
V <sub>IL Max.</sub>	1, 2, 3
I <sub>Ix</sub>	1, 2, 3
I <sub>CC</sub>	1, 2, 3
I <sub>SB1</sub>	1, 2, 3
I <sub>SB2</sub>	1, 2, 3
I <sub>OS</sub>	1, 2, 3

**Switching Characteristics**

Parameters	Subgroups
t <sub>RC</sub>	9, 10, 11
t <sub>A</sub>	9, 10, 11
t <sub>RR</sub>	9, 10, 11
t <sub>PR</sub>	9, 10, 11
t <sub>LZR</sub>	9, 10, 11
t <sub>DVR</sub>	9, 10, 11
t <sub>HZR</sub>	9, 10, 11
t <sub>WC</sub>	9, 10, 11
t <sub>PW</sub>	9, 10, 11
t <sub>HWZ</sub>	9, 10, 11
t <sub>WR</sub>	9, 10, 11
t <sub>SD</sub>	9, 10, 11
t <sub>ID</sub>	9, 10, 11
t <sub>MRSC</sub>	9, 10, 11
t <sub>PMR</sub>	9, 10, 11
t <sub>RMR</sub>	9, 10, 11
t <sub>RPW</sub>	9, 10, 11
t <sub>WPW</sub>	9, 10, 11
t <sub>RTC</sub>	9, 10, 11
t <sub>PRT</sub>	9, 10, 11
t <sub>RTR</sub>	9, 10, 11
t <sub>EFL</sub>	9, 10, 11
t <sub>HFH</sub>	9, 10, 11
t <sub>FFH</sub>	9, 10, 11
t <sub>REF</sub>	9, 10, 11
t <sub>RFF</sub>	9, 10, 11
t <sub>WEF</sub>	9, 10, 11
t <sub>WFF</sub>	9, 10, 11
t <sub>WHF</sub>	9, 10, 11
t <sub>RHF</sub>	9, 10, 11
t <sub>RAE</sub>	9, 10, 11
t <sub>RPE</sub>	9, 10, 11
t <sub>WAF</sub>	9, 10, 11
t <sub>WPF</sub>	9, 10, 11
t <sub>XOL</sub>	9, 10, 11
t <sub>XOH</sub>	9, 10, 11

Document #: 38-00079-G