

500mA, Step-Up DC/DC Converter

FEATURES

- High Efficiency 90%.
- Adjustable Output Voltage with Two Resistors (SS6631A)
- Power-Saving Shutdown Mode (7 μ A typical).
- Internal 2A Switch.
- 120KHz Switching Rate.
- Adjustable Switch Current Limit.
- On-Chip Low Battery Detector.

APPLICATIONS

- Palmtop & Notebook Computers.
- Pocket Organizers.
- Cameras.
- Pagers.
- Battery Backup Supplies.
- Portable Instruments.



DESCRIPTION

The SS6631 is a high efficiency step up DC-DC converter. Only four external components are required to deliver a fixed voltage of 3V, 3.3V, or 5V. The output voltage can be externally set to an arbitrary value below breakdown voltage of the power switch for SS6631A. Efficiency beyond 87% can be easily achieved at 100mA load with 2.2V to 3V input voltages.

Logic-controlled shutdown mode is provided for power saving. Switch current limit can be programmed with a resistor. The low battery detector can be configured as a linear regulator or a burst mode controller performing an extremely low supply current operation.

120KHz switching rate reduces the inductor size. Inductors of 25 μ H to 50 μ H inductance are recommended for most applications.

TYPICAL APPLICATION CIRCUIT

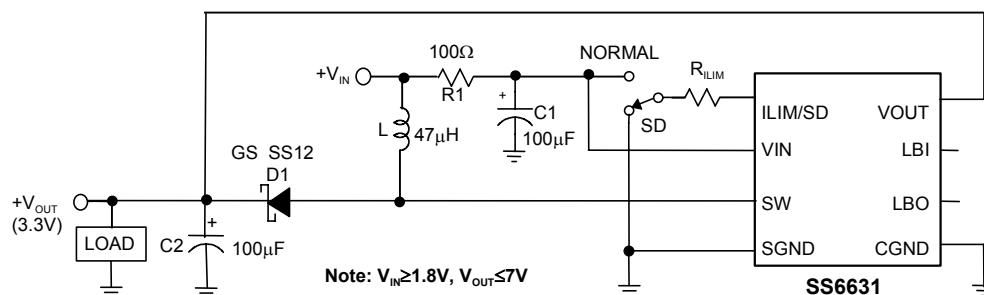
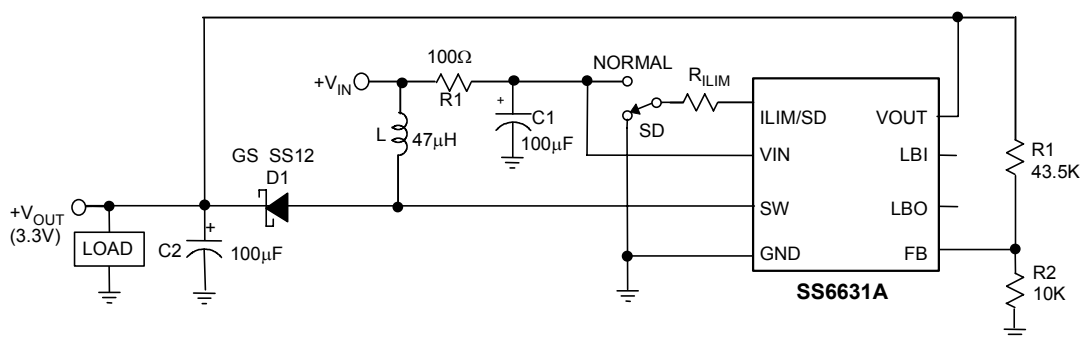

High Efficiency Step-Up DC/DC Converter

ORDERING INFORMATION

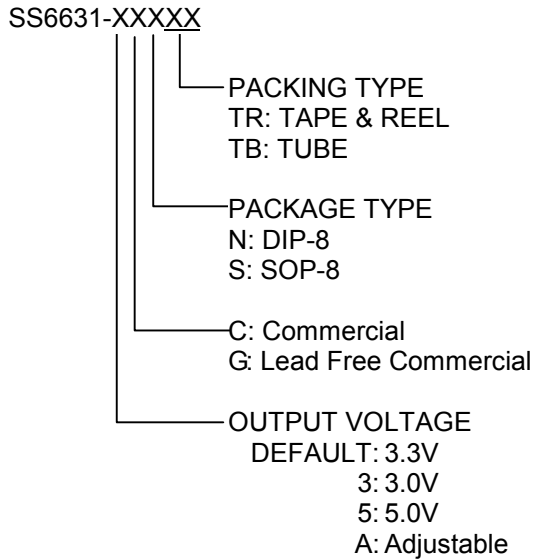

EX: SS6631-3CSTR
→ 3.0V Version, in SOP-8 Package & Tape & Reel Packing Type

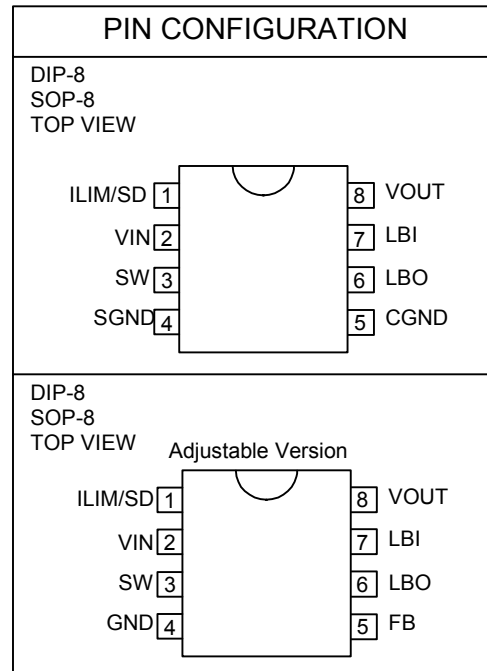

ABSOLUTE MAXIMUM RATINGS

Supply Voltage	7.0V
Operating Temperature Range	-40°C to 85°C
Maximum Junction Temperature	125°C
Storage Temperature Range	-65°C to 150°C
Lead Temperature (Soldering, 10 sec)	260°C

Absolute Maximum Ratings are those values beyond which the life of a device may be impaired.

TEST CIRCUIT

Refer to Typical Application Circuit.

■ ELECTRICAL CHARACTERISTICS

($V_{IN}=3.0V$, $T_A=25^{\circ}C$, unless otherwise specified.) (Note1)

PARAMETER	TEST CONDITIONS	MIN.	TYP.	MAX.	UNIT
Input Voltage	Fig. 14 in Appl. Examples	1.5		7	V
Output Voltage	$I_{LOAD}=200mA$ SS6631 SS6631-3 SS6631-5	3.16 2.88 4.80	3.3 3 5	3.44 3.12 5.20	V
Switch off Current			105	140	μA
No Load Current	SS6631/SS6631-3 SS6631-5		160 180		μA
Shutdown Mode Current			7	15	μA
Shutdown Recovery Time	$V_{IN}=2.5V$, $I_{LOAD}=200mA$		0.4		mS
Efficiency	$I_{LOAD}=200mA$ SS6631/SS6631-3 SS6631-5		87 90		%
Line Regulation	$I_{LOAD}=100mA$ SS6631, $V_{IN}=1.8 \sim 3.3V$ SS6631-3, $V_{IN}=1.8 \sim 3V$ SS6631-5, $V_{IN}=2.2 \sim 3.3V$		0.6 0.5 0.8		% V_{OUT}
Load Regulation	$I_{LOAD}=10\sim 300mA$ SS6631/SS6631-3 SS6631-5		0.3 0.8		% V_{OUT}
Oscillator Frequency		90	120	150	KHz
LBI Pin Trip Point		1.17	1.22	1.27	V
FB Threshold Voltage	SS6631A	0.598	0.617	0.636	V
SW "ON Resistance"	SS6631/SS6631-3 SS6631-5		0.5 0.4		Ω
LBO "ON Resistance"	$V_{IN}=2V$		45		Ω
SW Off Leakage				1	μA
Input Pin Bias Current				10	nA/Pin
Output Pin Leakage				10	nA/Pin

Note 1: Specifications are production tested at $T_A=25^{\circ}C$. Specifications over the $-40^{\circ}C$ to $85^{\circ}C$ operating temperature range are assured by design, characterization and correlation with Statistical Quality Controls (SQC).

■ TYPICAL PERFORMANCE CHARACTERISTICS

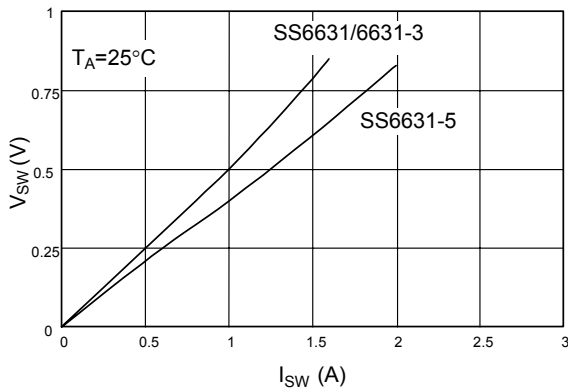

Fig. 1 Switch Voltage vs. Current

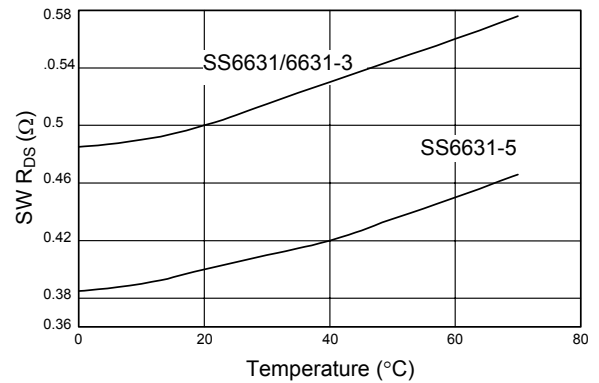

Fig. 2 SW ON Resistance vs. Temperature

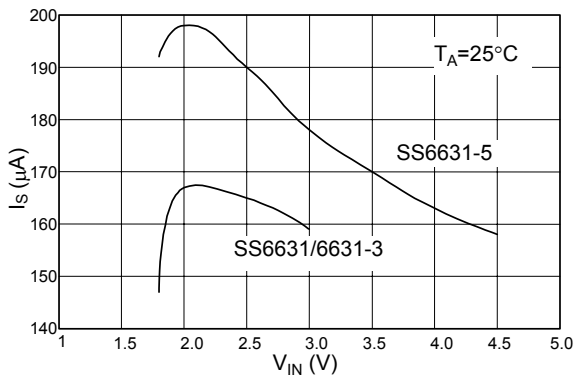

Fig. 3 No Load Supply Current vs. Input Voltage

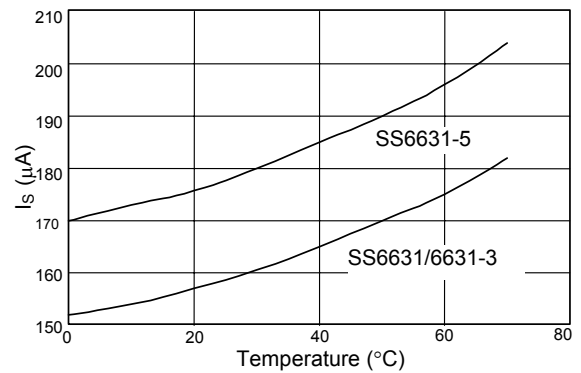

Fig. 4 No Load Supply Current vs. Temperature

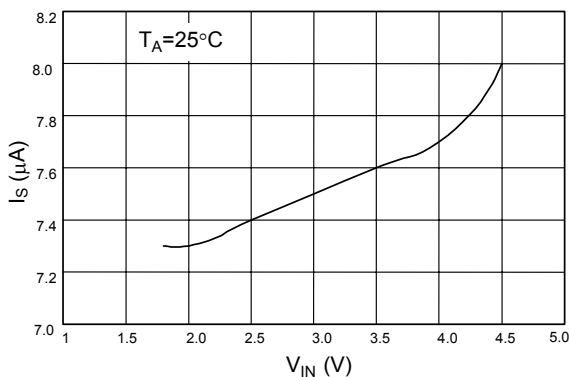

Fig. 5 Shutdown Mode Supply Current vs. Input Voltage

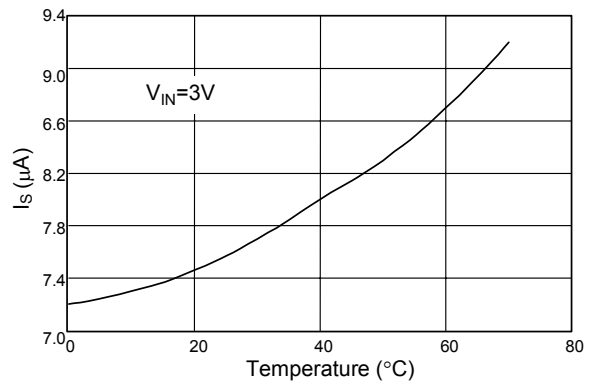

Fig. 6 Shutdown Mode Supply Current vs. Temperature

■ **TYPICAL PERFORMANCE CHARACTERISTICS (Continued)**

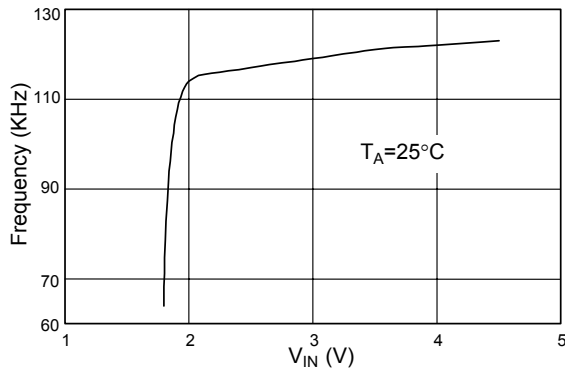

Fig. 7 Oscillator Frequency vs. Input Voltage

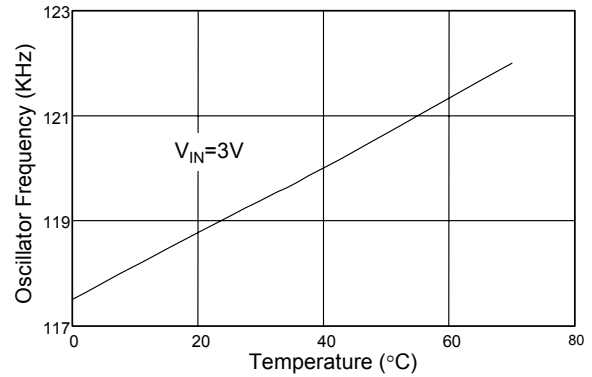

Fig. 8 Oscillator Frequency vs. Temperature

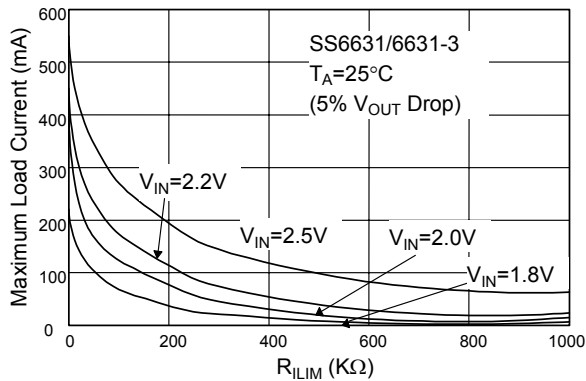

Fig. 9 Maximum Load Current vs. Switch Current Limit Resistance

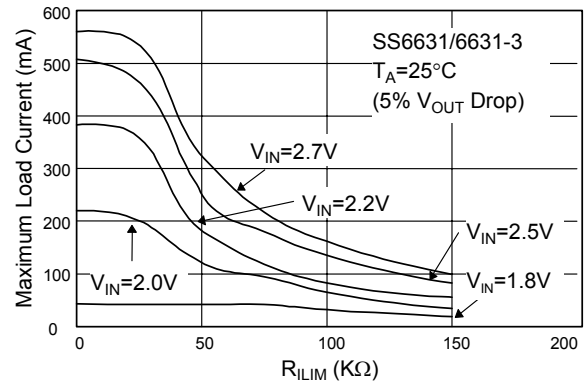
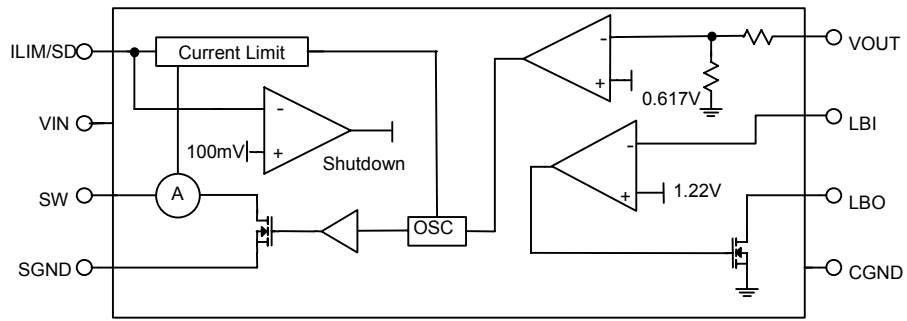
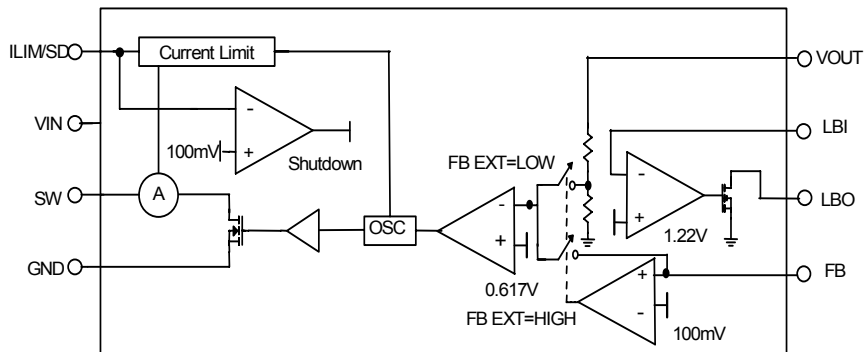

Fig. 10 Maximum Load Current vs. Switch Current Limit Resistance

■ BLOCK DIAGRAM



SS6631-3 / SS6631 / SS6631-5



The driver and reference (0.617V and 1.22V) for SS6630A are based on VOUT pin. And VOUT must be $\geq 2.2V$ then system can operate normally.

SS6631A

■ PIN DESCRIPTIONS

SS6631-3/ SS6631/ SS6631-5

- PIN 1: ILIM/SD- 1. Connected to VIN pin through a resistor to set the switch peak current. It serves to protect IC and inductor, as well as to improve efficiency and output ripples. However, supply capability of the SS6631 is limited by the current limit resistor. (See typical performance characteristics). The ILIM/SD pin should be shorted to VIN pin if limiting on switch peak current is not intended.
2. The SS6631 goes in shut-down mode and consumes less than 10 μ A when ILIM/SD pin is pulled to ground.
- PIN 2: VIN - Input supply.
- PIN 3: SW - Drain of the power switch, to be connected to inductor/ diode.
- PIN 4:SGND - Ground connected to source of power switch.
- PIN 5:CGND - Ground for control circuits of the IC. It should be separated from SGND to avoid the interference.
- PIN 6:LBO - Open drain output of the battery low detector, with 45 Ω "ON resistance" at V_{IN}=2V. It is pulled low when the voltage on LBI pin is below 1.22V.
- PIN 7:LBI - The noninverting input of the battery low detector, of which the inverting input is internally connects to 1.22V voltage reference.
- PIN 8:VOUT - The output voltage feedbacks to the IC through this pin.

SS6631A

- PIN 1: ILIM/SD- 1. Connected to VIN pin through a resistor to set the switch peak current. It serves to protect IC and inductor, as well as to improve efficiency and output ripples. However, supply capability of the SS6631A is limited by the current limit resistor. (See typical performance characteristics). The ILIM/SD pin should be shorted to VIN pin if limiting on switch peak current is not intended.
2. The SS6631A goes in shut-down mode and consumes less than 10 μ A when ILIM/SD pin is pulled to ground.
- PIN 2: VIN - Input supply.
- PIN 3: SW - Drain of the power switch, to be connected to inductor/ diode.
- PIN 4: GND - Ground.
- PIN 5: FB - Output voltage can either be internally set to 5 volt by grounding FB pin, or be externally set to an arbitrary voltage by applying to FB pin the divider voltage of two divider resistors.
- VOUT voltage is given by the following equation:
- $$\frac{R1}{R2} = \frac{V_{OUT}}{0.617} - 1$$
- where R1 = Resistor connected between FB pin and VOUT pin.
- R2= Resistor connected between FB pin and ground.
- VOUT=Output voltage to be set.
- PIN 6: LBO - Open drain output of the battery low detector, with 45 Ω "ON resistance" at V_{IN}=2V. It is pulled low when the voltage on LBI pin is below 1.22V.

SS6631A (continued)

PIN 7: LBI - The noninverting input of the battery low detector, of which the inverting input is internally connects to 1.22V voltage reference.

PIN 8: VOUT- The output voltage feedbacks to the IC through this pin. If output voltage was externally set, the VOUT pin can be tied to any low impedance node with voltage between the external power switch threshold and 7V.

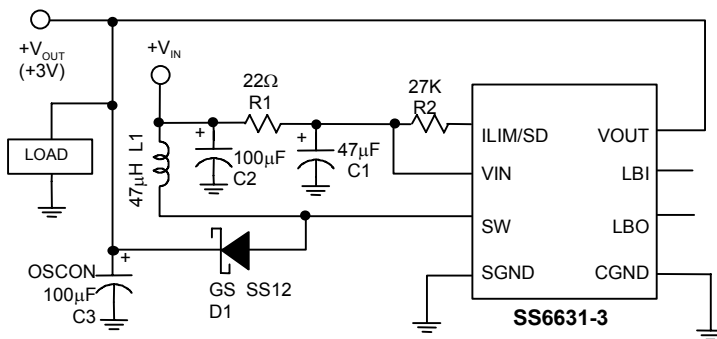
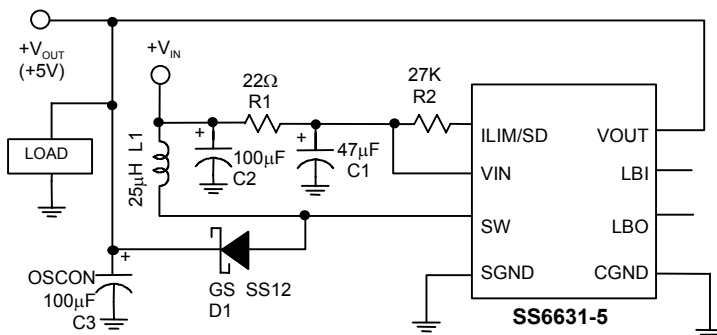
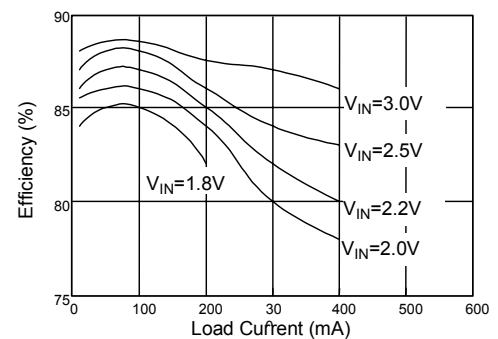
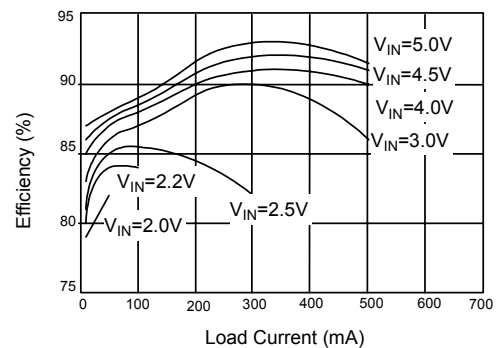
APPLICATION EXAMPLES

Fig. 11 3V Output Step-Up Converter

Fig. 12 5V Output Step-Up Converter

APPLICATION EXAMPLES (Continued)

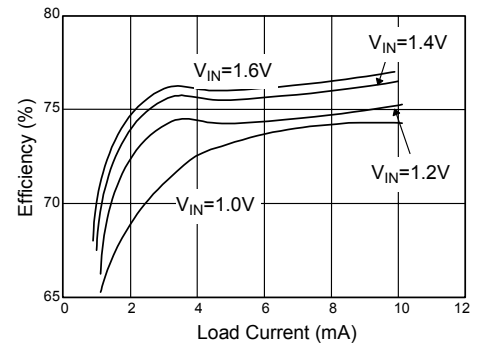
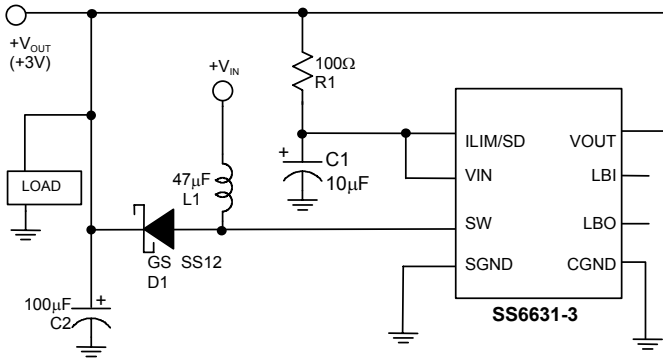

Fig. 13 1-Cell Input 3V Output Step-Up Converter

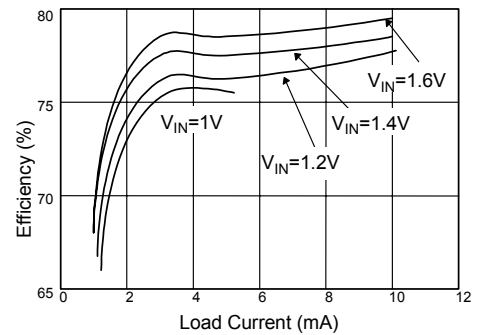
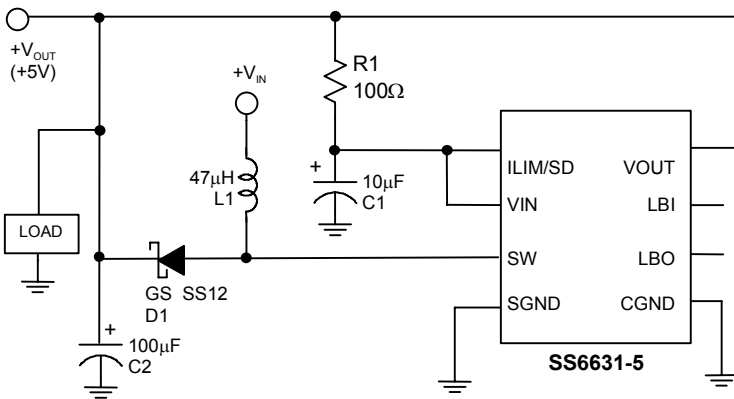

Fig. 14 1-Cell Input 5V Output Step-Up Converter

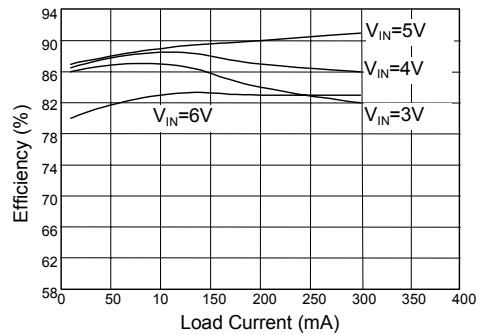
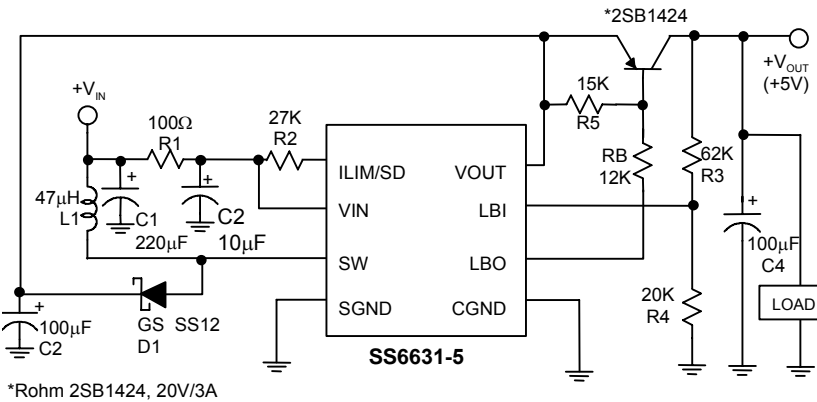

Fig. 15 4-Cell Input Step-Up / Step-Down Converter

■ APPLICATION EXAMPLES (Continued)

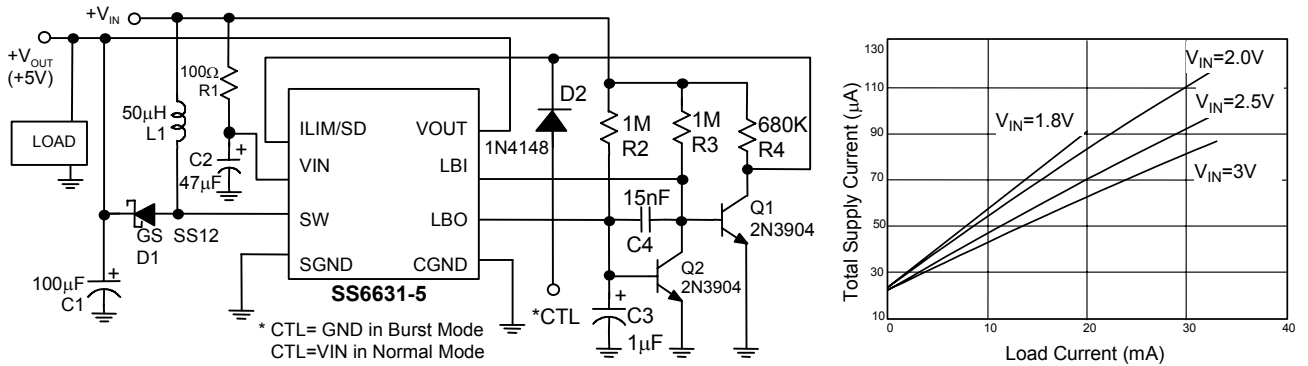

Fig. 16 Low Supply Current Burst Mode Step-Up Converter

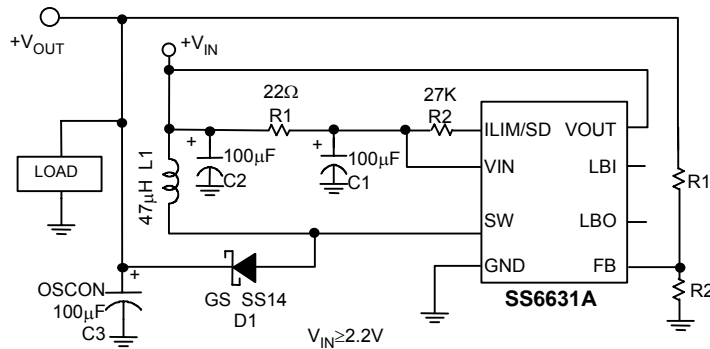

Fig. 17 Adjustable Output Voltage Step-Up Converter

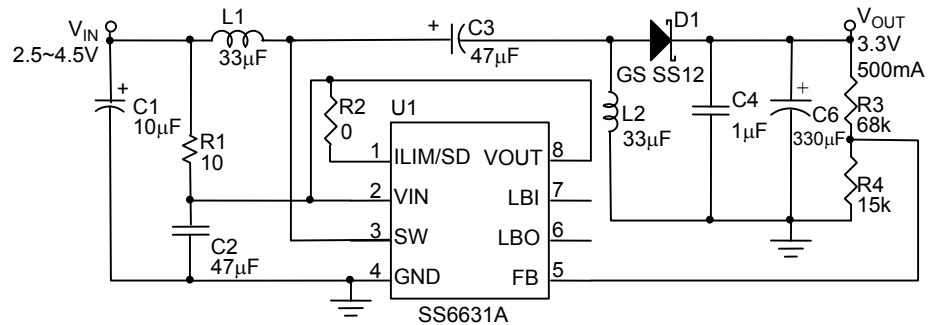

Fig. 18 SEPIC Circuit of the DC-DC Converter

■ APPLICATION EXAMPLES (Continued)

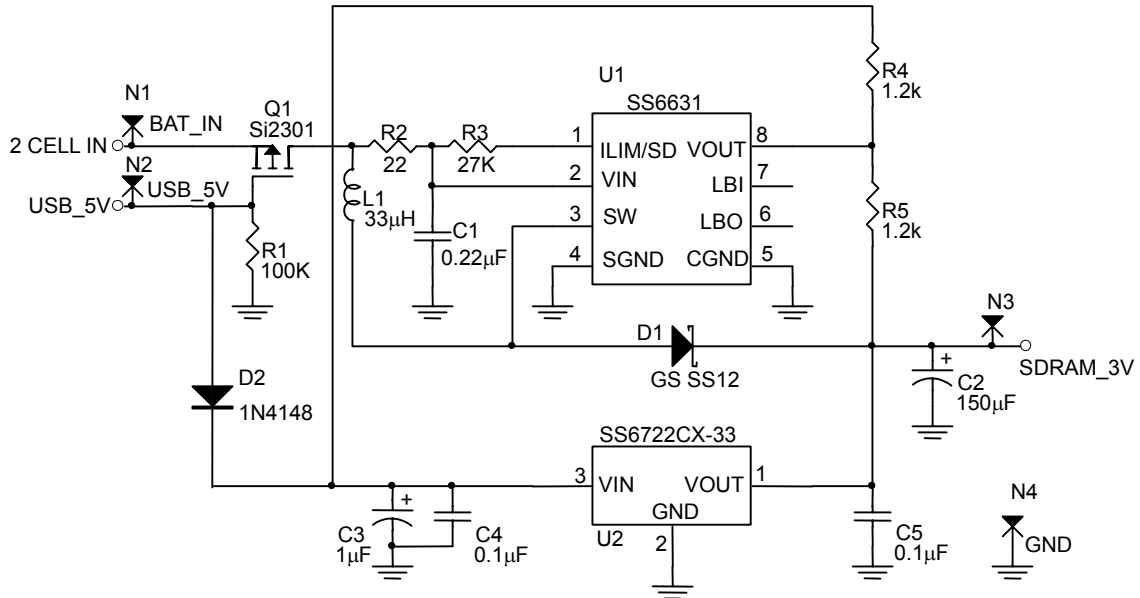
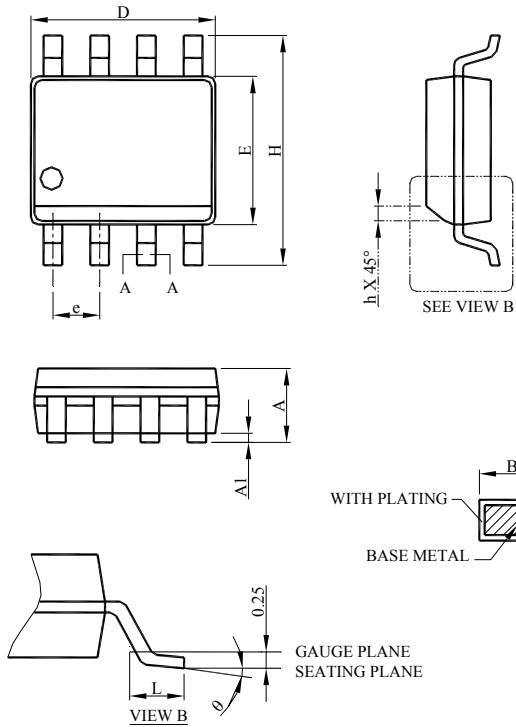
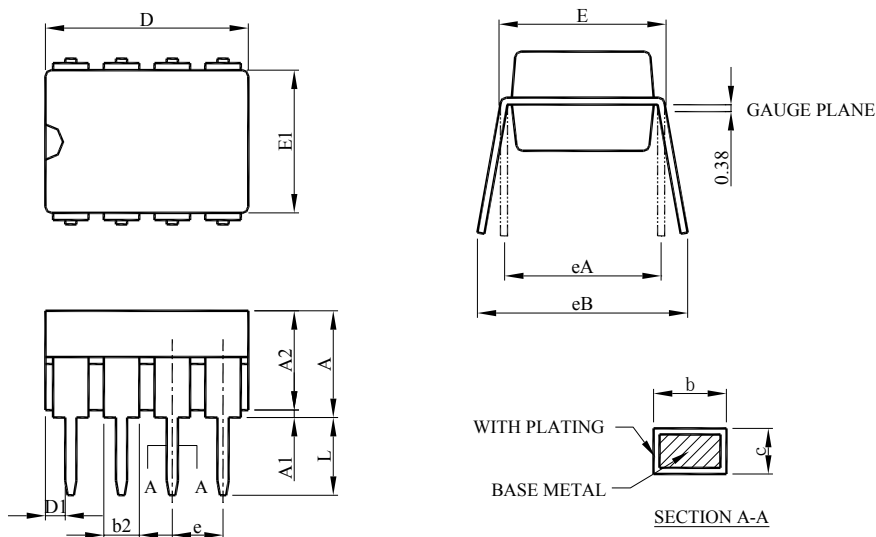

Fig. 19 USB Dual Input Application of SDRAM

PHYSICAL DIMENSION (unit: mm)
● SOP-8

SYMBOL	SOP-8	
	MILLIMETERS	
	MIN.	MAX.
A	1.35	1.75
A1	0.10	0.25
B	0.33	0.51
C	0.19	0.25
D	4.80	5.00
E	3.80	4.00
e	1.27 BSC	
H	5.80	6.20
h	0.25	0.50
L	0.40	1.27
θ	0°	8°

● DIP-8

SYMBOL	DIP-8	
	MILLIMETERS	
	MIN.	MAX.
A		5.33
A1	0.38	
A2	2.92	4.95
b	0.36	0.56
b2	1.14	1.78
c	0.20	0.35
D	9.01	10.16
D1	0.13	
E	7.62	8.26
E1	6.10	7.11
e	2.54 BSC	
eA	7.62 BSC	
eB		10.92
L	2.92	3.81

Information furnished by Silicon Standard Corporation is believed to be accurate and reliable. However, Silicon Standard Corporation makes no guarantee or warranty, expressed or implied, as to the reliability, accuracy, timeliness or completeness of such information and assumes no responsibility for its use, or for infringement of any patent or other intellectual property rights of third parties that may result from its use. Silicon Standard reserves the right to make changes as it deems necessary to any products described herein for any reason, including without limitation enhancement in reliability, functionality or design. No license is granted, whether expressly or by implication, in relation to the use of any products described herein or to the use of any information provided herein, under any patent or other intellectual property rights of Silicon Standard Corporation or any third parties.