

GaAs HIGH POWER T-1 PACKAGE

INFRARED EMITTING DIODE

MIE-304G1

Description

The MIE-304G1 is an infrared emitting diode in GaAs technology molded in water clear plastic package.

Package Dimensions

Unit : mm (inches)

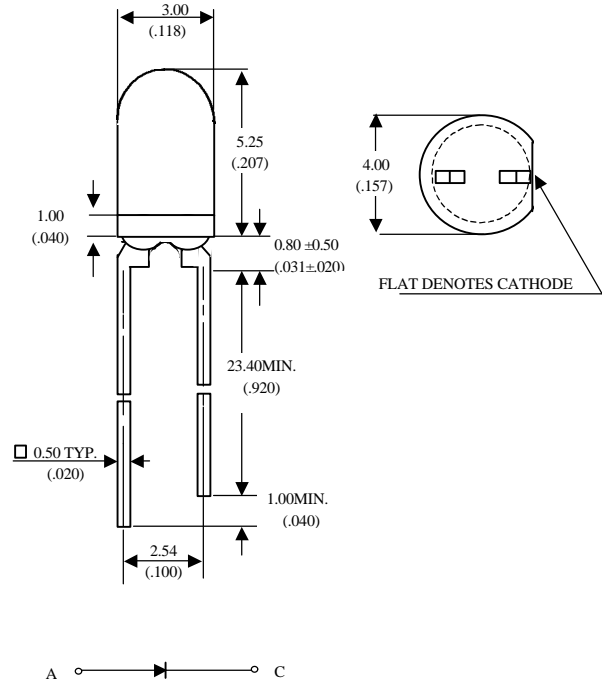

Features

- Standard T-1 (ϕ 3mm) package, radiation angle : $\pm 10^\circ$
- Peak wavelength $\lambda_p = 940$ nm
- Good spectral matching to si-photodetector

Notes :

1. Tolerance is ± 0.25 mm (.010") unless otherwise noted.
2. Protruded resin under flange is 0.8 mm (.031") max.
3. Lead spacing is measured where the leads emerge from the package.

Absolute Maximum Ratings

@ $T_A = 25^\circ\text{C}$

Parameter	Maximum Rating	Unit
Power Dissipation	120	mW
Peak Forward Current	1	A
Continuous Forward Current	100	mA
Reverse Voltage	5	V
Operating Temperature Range	-55°C to +100°C	
Storage Temperature Range	-55°C to +100°C	
Lead Soldering Temperature	260°C for 5 seconds	

UNI

Unity Opto Technology Co., Ltd.

02/04/2002

Optical-Electrical Characteristics

@ T_A=25°C

Parameter	Test Conditions	Symbol	Min.	Typ .	Max.	Unit
Radiant Intensity	I _F =20mA	I _e	1.5	2.5		mW/sr
Forward Voltage	I _F =50mA	V _F		1.30	1.5	V
Reverse Current	V _R =5V	I _R			100	μA
Peak Wavelength	I _F =20mA	λ		940		nm
Spectral Bandwidth	I _F =20mA	Δλ		50		nm
View Angle	I _F =20mA	2 θ _{1/2}		20		deg .

Typical Optical-Electrical Characteristic Curves

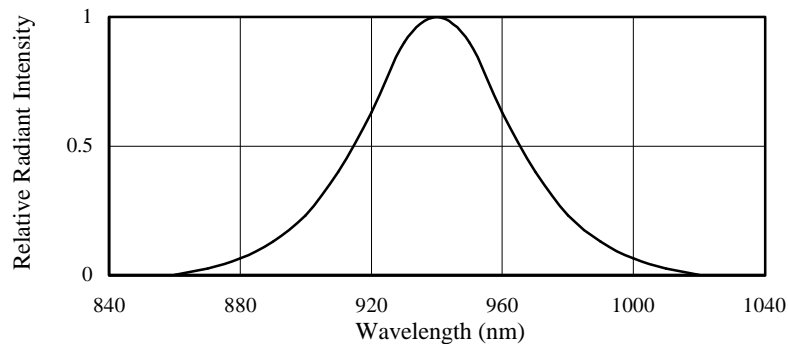

FIG.1 SPECTRAL DISTRIBUTION

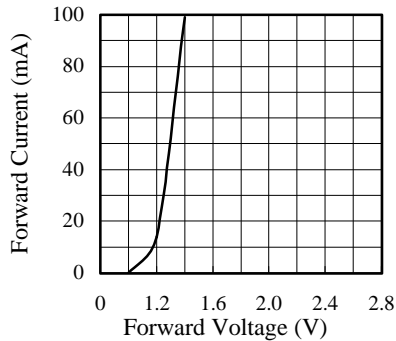

FIG.2 FORWARD CURRENT VS. FORWARD VOLTAGE

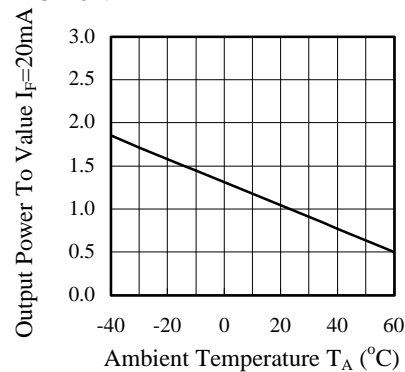

FIG.3 RELATIVE RADIANT INTENSITY VS. AMBIENT TEMPERATURE

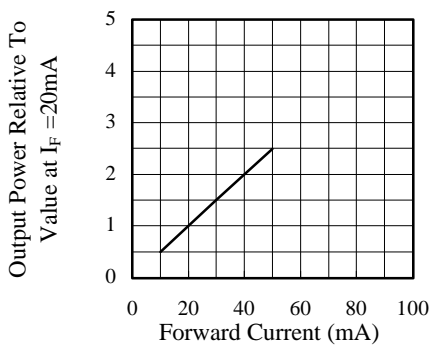

FIG.4 RELATIVE RADIANT INTENSITY VS. FORWARD CURRENT

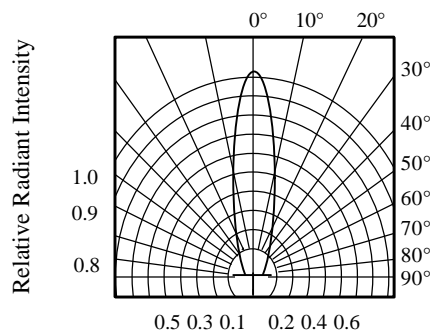

FIG.5 RADIATION DIAGRAM