

RECOMMENDED PCB LAYOUT
GENERAL TOLERANCE ±0.05
WITHOUT BOSS

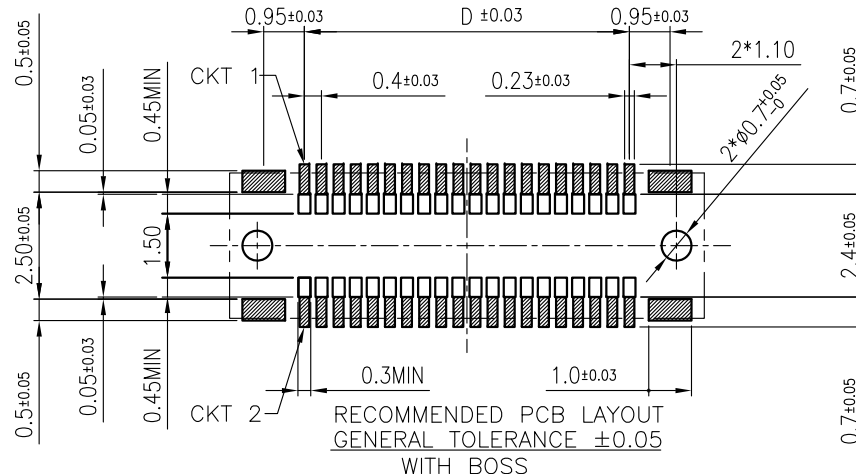

RECOMMENDED PCB LAYOUT
GENERAL TOLERANCE ±0.05
WITH BOSS

NOTES:

1. MATERIAL:

1.1 HOUSING: THERMOPLASTIC, HIGH TEMP.,
UL94V-0; COLOR:BLACK.

1.2 CONTACT: COPPER ALLOY

1.3 FITTING NAIL: COPPER ALLOY

2. FINISH:

2.1 CONTACT:

GOLD FLASH PLATING OVERALL(1~3u") .
50~100u" NICKEL UNDERPLATING OVERALL.

2.2 FITTING NAIL:

100~200u" MATT TIN PLATING ON SOLDER TAILS.
50~100u" NICKEL UNDERPLATING OVERALL.

3. REFLOW SOLDER CAPABLE TO 260°C
PER ACES SPEC.

5. SPEC. PLS. REFER TO PS-50007-xxxx-xxx

6. PACKAGE PLS. REFER TO 88664-XXXX-TRP(WITHOUT BOSS)
88664-XXXXB-TRP(WITH BOSS)

7. PART NUMBER

50008-XXX X X-XXX

XXX	Housing Color	Halogen Free	Polarization
001	Black	HF	with boss
002	Black	HF	without boss

PLATING

1: GOLD FLASH OVER ALL

PACKING

- 0: TAPE & REEL
- 1: TUBE PACKAGE
- 4: TAPE & REEL WITH MYLAR
- 5: TUBE PACKAGE WITH MYLAR

No Of CKT

CKT	Dim A	Dim B	Dim C	Dim D	MYLAR SIZE
10	5.10	3.50	2.44	1.60	2.5
12	5.50	3.90	2.84	2.00	
20	7.10	5.50	4.44	3.60	
24	7.90	6.30	5.24	4.40	
26	8.30	6.70	5.64	4.80	3.0
30	9.10	7.50	6.44	5.60	
40	11.10	9.50	8.44	7.60	
50	13.10	11.50	10.44	9.60	
60	15.10	13.50	12.44	11.60	5.0
70	17.10	15.50	14.44	13.60	
80	19.10	17.50	16.44	15.60	
90	21.10	19.50	18.44	17.60	
100	23.10	21.50	20.44	19.60	15.0
120	27.10	25.50	24.44	23.60	

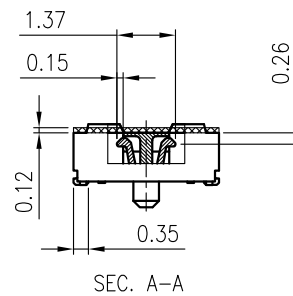
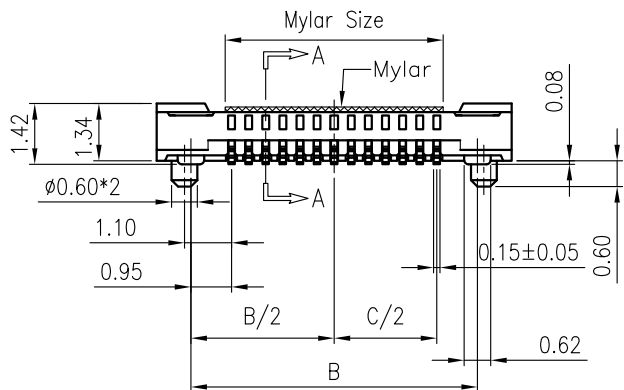
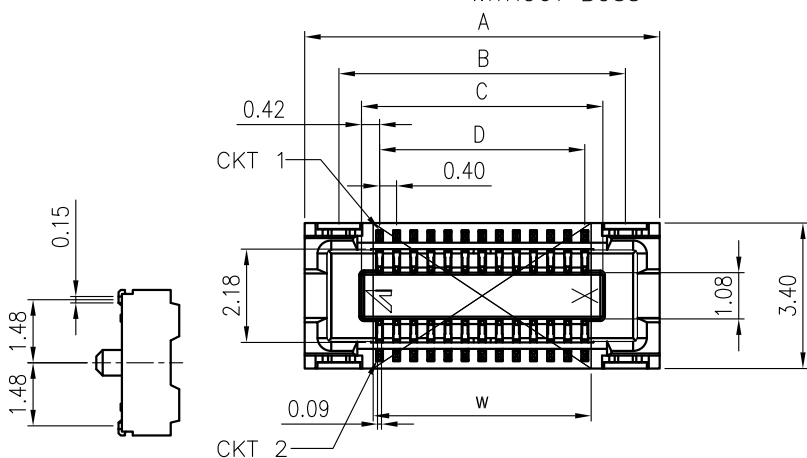

一般公差 TOLERANCES X ±0.5 XX ±0.15 X ±0.25 XXX ±0.1 ANGLES ±2°		宏致電子股份有限公司 Aces Electronic Co.,Ltd.	
檢驗尺寸標示 SYMBOLS (M) (P) INDICATE CLASSIFICATION DIMENSION	品名 (TITLE) 0.4mm BTB D/R RCPT SMT S/T TYPE	製圖 (DR) 11/04/22 yangwu	審核 (CHKD) CARL
(M) MARK IS CRITICAL DIM. (P) MARK IS MAJOR DIM.	圖號 (DWG.NO) 50008-XXXXX-XXX	核准 (APPD) JASON	
表面處理 (FINISH)	比例 (SCALE) 單位 (UNITS) 6:1 mm	張數 (SHEET) 1 OF 1	圖號 (DWG.NO) 1 OF 1 SIZE A4 REV C