

Technical Data

S1528 Series



Description

A voltage controlled crystal oscillator providing precise rise and fall times to drive high performance applications. The device is packaged in a 6-pin, SMD, J leaded package. The plastic molded surface mountable package is ideal for today's automated assembly environments.

Applications

- For use with phase-locked loop (PLL) for clock and data recovery, frequency translation, or frequency synthesis applications in video, telephony, and data communication environments.
- Plastic molded, J-lead SMD package
- TTL and CMOS compatible
- Tri-state output
- For frequencies above 27 MHz, see SaRonix S1518 Series
- Available as 3.3V version, see SaRonix S1328 Series
- Available on tape & reel; 24mm tape, 500pcs per reel

Output Waveform

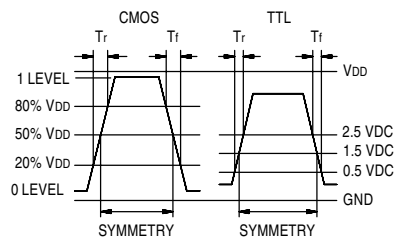

Frequency Range:	1.5 MHz to 27 MHz
Frequency Stability:	±50 ppm over all conditions: operating temperature, voltage change, load change, calibration tolerance, aging, with $V_C = 2.5V$
Temperature Range:	Operating: 0 to +70°C, 0 to +85°C, -40 to +85°C Storage: -55 to +125°C
Supply Voltage:	Recommended Operating: 5V ±5%
Supply Current:	20mA typ, 30mA max @ 25°C, 40mA max @ operating temp range
Output:	Symmetry: See Part Numbering Guide and Output Waveform Rise & Fall Times: 5ns max, 20% to 80% VDD, CMOS 4ns max, 0.4V to 2.4 VDC, TTL Logic 0: 10% VDD max for CMOS or 0.4 VDC max for TTL Logic 1: VCC -0.6 VDC for CMOS or 2.4 VDC min for TTL Load: 50pF or 10 TTL Period Jitter RMS: 8ps max
Pull Characteristics:	Input Impedance: 50KΩ min Frequency Response (-3dB): 20kHz Pullability: ±20, ±50, ±70, ±100 ppm APR* (See Part Numbering Guide) Control Voltage: 0.5 to 4.5V Transfer Function: Frequency increases when Control Voltage increases Linearity: 10% max Center Control Voltage: 2.5V
Mechanical:	Shock: MIL-STD-883, Method 2002, Condition B Solderability: MIL-STD-883, Method 2003 Terminal Strength: MIL-STD-202, Method 211, Conditions A & C Vibration: MIL-STD-883, Method 2007, Condition A Resistance to Soldering Heat: MIL-STD-202, Method 210, Condition I or J
Environmental:	Thermal Shock: MIL-STD-883, Method 1011, Condition A Moisture Resistance: MIL-STD-883, Method 1004

* APR = (VCXO Pull relative to specified Output Freq. @ nominal control voltage) - (VCXO Freq. Stability)

Technical Data

S1528 Series

Tri-State Logic Table

Pin 2 Input	Pin 4 Output
Logic 1 or NC	Oscillation
Logic 0 or GND	High Impedance or Standby Function

Required Input Levels on Pin 2:
 Logic 1 = 3.0V min
 Logic 0 = 0.5V max

Package Details

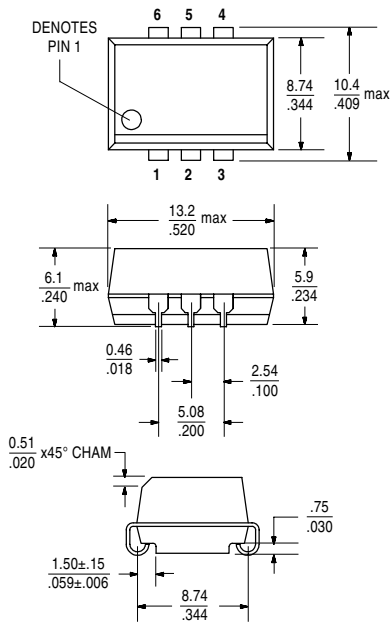

Pin Functions:

Pin 1: Control Voltage Pin 4: Output
 Pin 2: Tri-State Control Pin 5: N/C
 Pin 3: GND Pin 6: +5VDC (V_{CC})

Scale: None (Dimensions in $\frac{\text{mm}}{\text{inches}}$)

Recommended Land Pattern

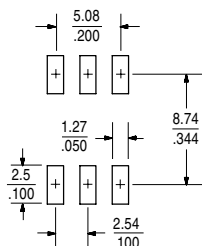

Solder Reflow Guide

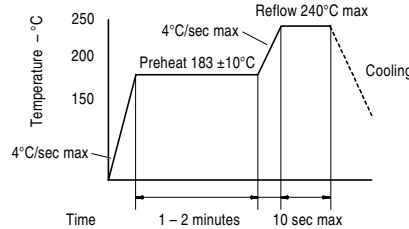

Part Numbering Guide

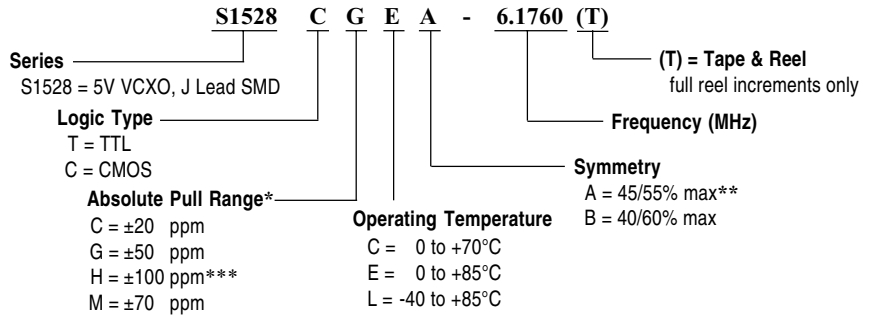

* APR = (VCXO Pull relative to specified Output Freq. @ nominal control voltage) - (VCXO Freq. Stability)
 ** Not available at all frequencies; TTL 13.5 to 27 MHz only
 *** Not available at all frequencies and all operating temperature ranges, please contact SaRonix

Test Circuits

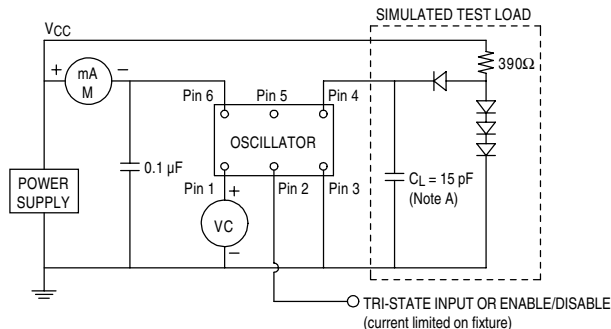

NOTE A: C_L includes probe and jig capacitance.
TTL TEST CIRCUIT

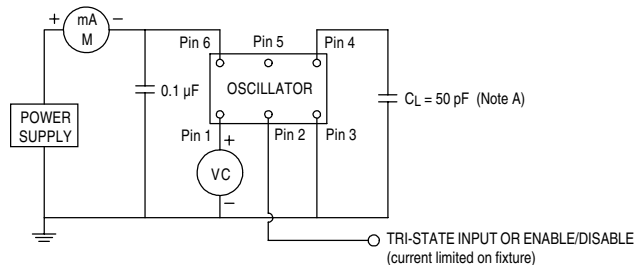

NOTE A: C_L includes probe and jig capacitance.
HCMOS TEST CIRCUIT