

LOW-COST PERFORMANCE

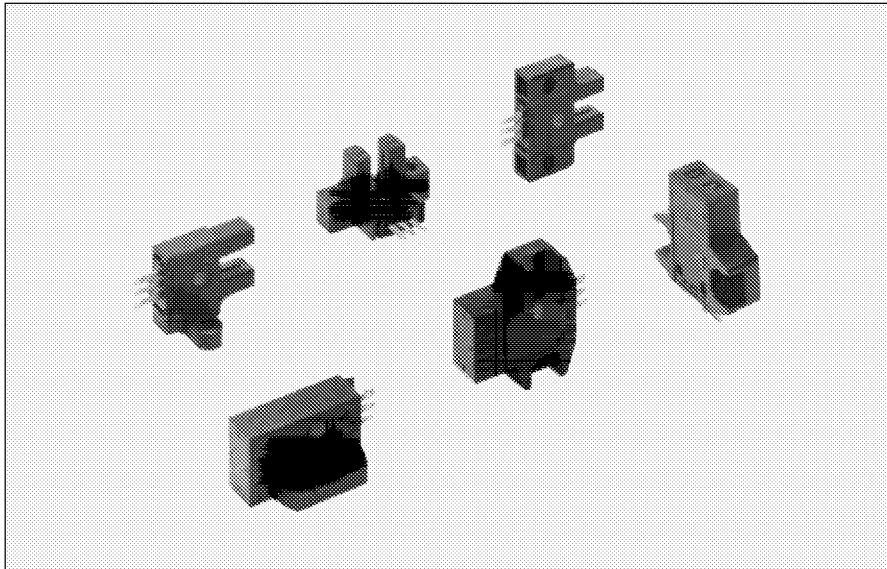

Stable Detection with a Fixed-focus Reflective / UZJ1□□

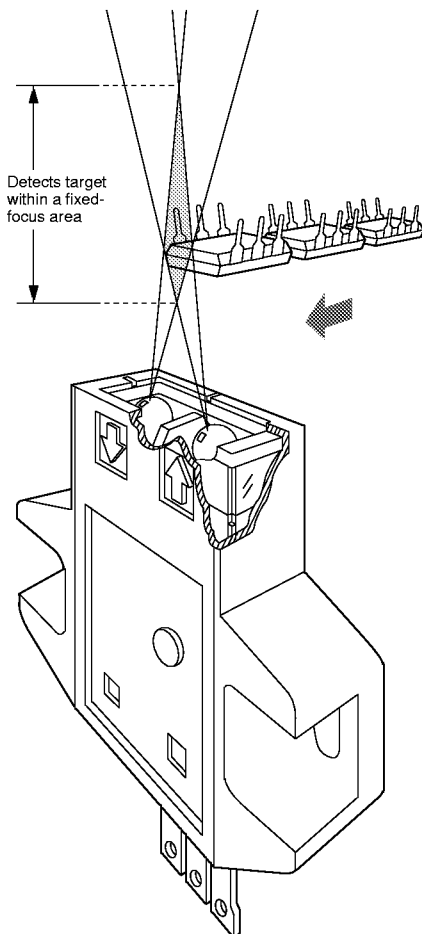

Not Affected by Background
The background will not affect the sensing performance if it is located 30mm (1.181inch) or more away.

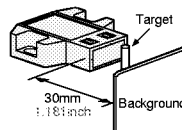

Dark Workpiece Detection
The sensor can detect even dark workpieces.

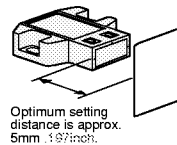

Tiny Object Detection
High performance of the sensor allows the detection of even a $\phi 0.05\text{mm}$ $\phi .002\text{inch}$ copper wire.

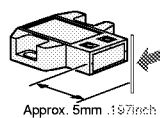

High-speed-Response Time: 20 μs / UZJ2□□

High-speed-Response Time: 20 μs (In the light-receiving condition)

Wide Product Range

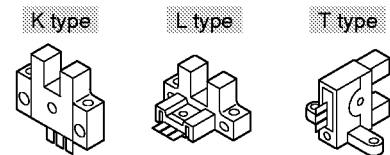

DC Power Operated
A supply voltage of 5 to 24V DC $\pm 10\%$ is required.

Cable type is also available
No soldering required.
Achieves space saving & reliability.

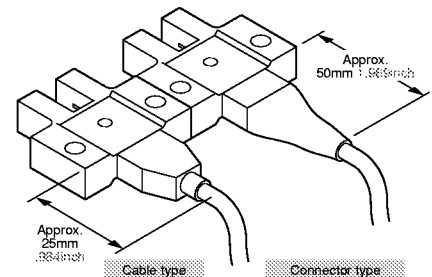

APPLICATIONS

Presence sensing of a capacitors on trays

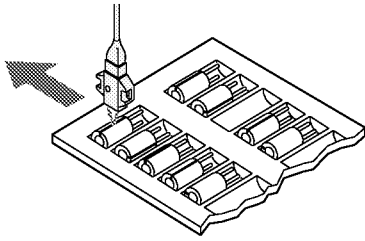



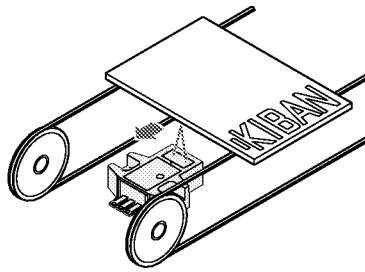

Positioning and pass sensing of circuit boards

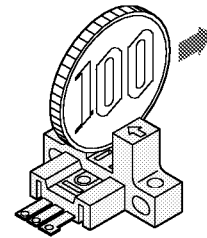

Counting of coins

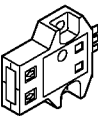

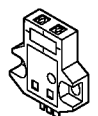
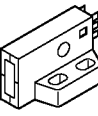
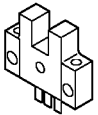
ORDER GUIDE

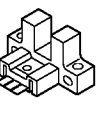
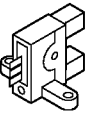
	Appearance	Sensing range	Model No.	Output operation
Fixed-focus reflective	 Top sensing	 2.5 to 8mm .098 to .315inch Center 5mm .197inch	UZJ101	Light-ON
			UZJ102	Dark-ON
	 Front sensing		UZJ111	Light-ON
			UZJ112	Dark-ON
	 L type (top sensing)		UZJ121	Light-ON
			UZJ122	Dark-ON
U-shaped thru-beam	 K type	 5mm .197inch (Fixed)	UZJ251	Dark-ON
			UZJ252	Light-ON
	 L type		UZJ261	Dark-ON
			UZJ262	Light-ON
			 T type	UZJ271
	UZJ272			Light-ON

With cable type (for U-shaped type only)

U-shaped type is available with cable.
 (Cable length: 1m 3.28ft). When ordering this type, add suffix "B" to the end of the model number.

e.g.): Cable type of **UZJ251** is "**UZJ251B**".

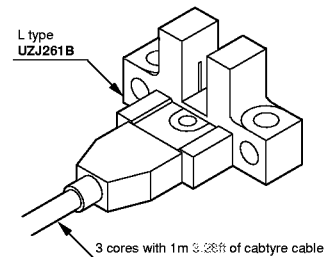

OPTION

Component	Model No.	Description
Connector	UZJ840	Dedicated connector
Connector with cable	UZJ841	Cable length: 1m 3.28ft
	UZJ842	Cable length: 3m 9.84ft

Connector
 • **UZJ840**

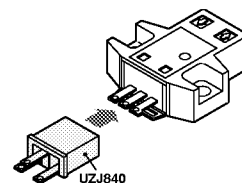

Connector with cable
 • **UZJ841**
 • **UZJ842**

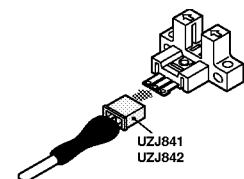

SPECIFICATIONS

Sensing mode		Fixed-focus reflective						U-shaped thru-beam					
		Top sensing		Front sensing		L type (top sensing)		K type		L type		T type	
Data	Model No.	UZJ101	UZJ102	UZJ111	UZJ112	UZJ121	UZJ122	UZJ251	UZJ252	UZJ261	UZJ262	UZJ271	UZJ272
Sensing range	2.5 to 8mm .098 to .315inch (center: 5mm .197inch) with non-glossy white paper (15×15mm .591×.591inch) (*1)						5mm .197inch (Fixed)						
Min. sensing object	ø0.05mm ø.002inch copper wire (at 5mm .197inch)						0.8×1.8mm .031×.071inch translucent object						
Hysteresis	Max. 20% of an operation range						0.05mm .002inch						
Repeatability	0.08mm .003inch (vertical direction for a light axis) (*2)						0.03mm .001inch						
Supply voltage	5 to 24 V DC ± 10% Ripple P-P: Max. 5%						5 to 24 V DC ± 10% Ripple P-P: Max. 10%						
Consumption	Average: Max. 25mA, Peak: Max. 80mA						Max. 30mA						
Output	NPN open-collector transistor Sink current: Max. 100mA Applied voltage: Max. 30V DC Residual voltage: Max. 1V (at 100mA sink current) Max. 0.4V (at 16mA sink current)												
Output operation	Light-ON	Dark-ON	Light-ON	Dark-ON	Light-ON	Dark-ON	Dark-ON	Light-ON	Dark-ON	Light-ON	Dark-ON	Light-ON	Dark-ON
Short-circuit protection	Equipped						—						
Response time	Max. 0.8ms						At the light-receiving condition: Max. 20µs At the light-interrupted condition: Max. 200µs (response frequency: Min. 500Hz) (*3)						
Operation indicator	Red LED (turns on when the output is in the ON state)												
Environmental resistance	Ambient temperature	-10 to +55°C +14 to +131°F, Storage: -25 to +80°C -13 to +176°F						-25 to +60°C -13 to +140°F, Storage: -30 to +80°C -22 to +176°F					
	Ambient humidity	45 to 85%RH (with no dew nor ice condensation), Storage: 45 to 85%RH											
	Ambient light	Sun light: 11,000lx at the light-receiving face, Incandescent: 3,500lx at the light-receiving face						Fluorescent light: 1,000lx at the light-receiving face					
	Noise	Power line: 240Vp with 10ms cycle and 0.5µs pulse duration, Radiation: 300Vp with 10ms cycle and 0.5µs pulse duration (by a noise simulator)						Power line: 200Vp with 10ms cycle and 1µs pulse duration, Radiation: 400Vp with 10ms cycle and 1µs pulse duration (by a noise simulator)					
	Vibration	1.5mm .059inch amplitude at the frequency of 10 to 55Hz in each of X, Y, and Z directions for 2 hours each in the power OFF state						1.5mm .059inch amplitude at the frequency of 10 to 2,000Hz (peak acceleration: 20G) in each of X, Y, and Z directions for 4 cycles (4 minute cycle) each in the power OFF state					
	Shock	500m/s ² (approx. 50G) impulse in each of X, Y, and Z directions for 3 times each in the power OFF state						15,000m/s ² (approx. 1,500G) impulse in each of X, Y, and Z directions for 3 times each in the power OFF state (0.5ms pulse shock)					
Emitting Element	Infrared LED (modulated)						Infrared LED (non-modulated)						
Material	Enclosure: Polycarbonate, Terminal part: HSM (Ag plating)						Enclosure: PBT, Terminal part: HSM (Ag plating)						
Cable extension	Extensible up to 2m 6.56ft by using a min. 0.3mm ² cable. (If the cable is extended for more than 2m 6.56ft, capacitor of 10µF must be connected between + V and 0V terminals.)						Extensible up to 100m 328.08ft by using a min. 0.3mm ² cable						
Weight	Approx. 4.5g .16oz				Approx. 4g .14oz		Approx. 3g .11oz						

(*1): The sensing range may extend to 12.5mm .492inch in maximum with white non-glossy paper on a certain product.

(*2): Repeatability of the fixed-focus reflective sensor is tested using a non-glossy white paper (15×15mm .591×.591inch) at 5mm .197inch.

(*3): Response frequency of the U-shaped type is tested using the disc as shown below.

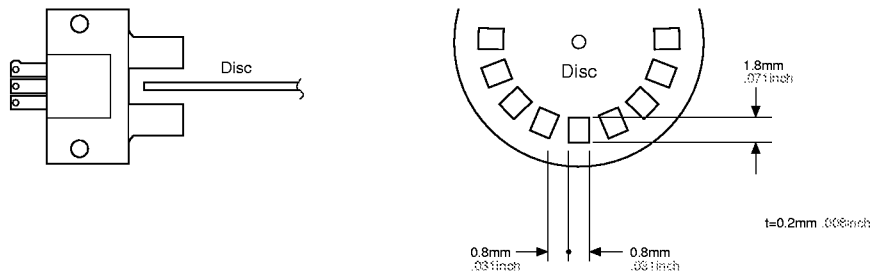

TYPICAL WIRING DIAGRAMS

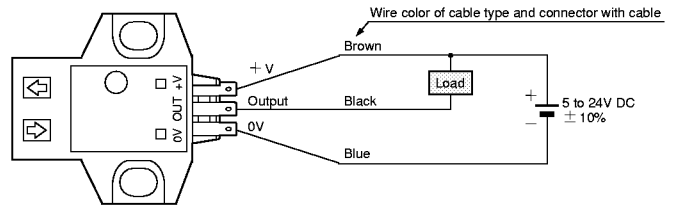
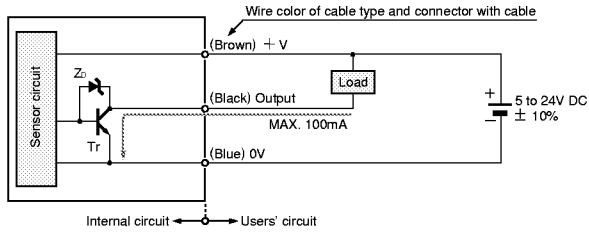

Symbol ... ZD: Surge absorption zener diode
Tr: NPN output transistor

SENSING FIELDS

These are typical sensing fields, which may vary slightly from unit to unit.

UZJ1

Sensing field

Horizontal (left and right) direction

The sensors can be mounted side by side.

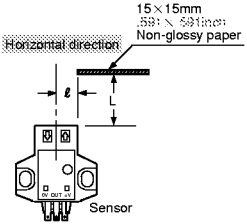
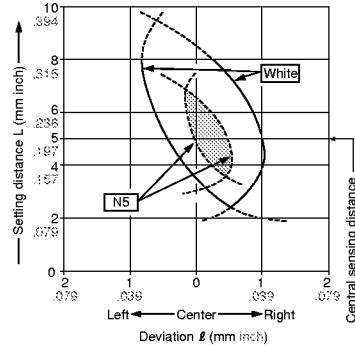

Vertical (up and down) direction

The sensors can be mounted side by side.

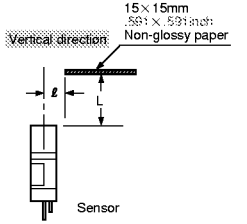
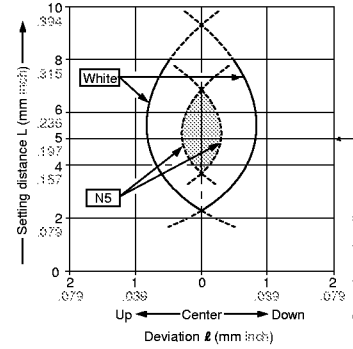

Brightness – Sensing range correlation

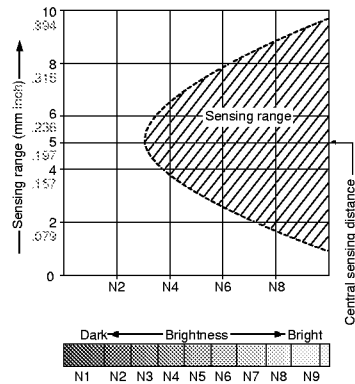

The shaded area shown in the figure at left indicates the sensing range. Be sure to set up the sensor with enough margin – the sensing range may vary from unit to unit.

(The brightness indicated in the left figure may vary slightly from the actual brightness.)

Material (15x15mm .591x.591inch) – Sensing range correlation

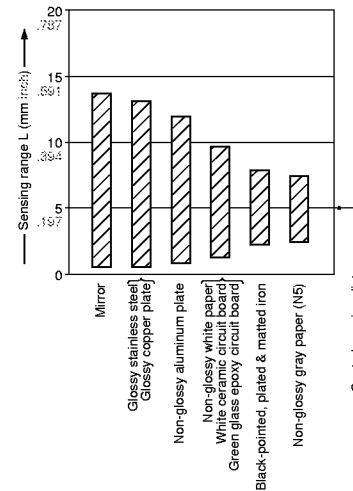

The bar graph on the left indicates the sensing range. Be sure to set up the sensor with enough margin – the sensing range may vary from unit to unit.

PRECAUTIONS FOR PROPER USE

All models



These products are **not** safety sensors and are **not** designed or intended to be used to protect life and prevent bodily injury or property damage.

Mounting

To mount the sensor, use M3 screw and $\phi 6\text{mm}$ $\phi .236\text{inch}$ diameter washer with the following tightening torque.

Model No.	Tightening torque
UZJ1□□	0.49N·m {5kgf·cm}
UZJ25□	
UZJ27□	
UZJ26□	0.29N·m {3kgf·cm}

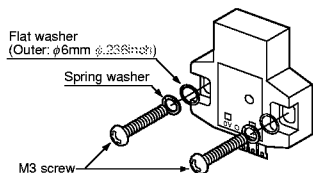

Soldering

When soldering directly to the terminals, strictly observe the following conditions.

Model No.	UZJ1□□	UZJ2□□
Item		
Soldering temperature	Max. 260°C 500°F	
Soldering time	Max. 10 sec.	Max. 3 sec.
Soldering position	Refer to the figure at the right	

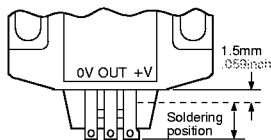

Wiring

Make sure to connect the frame ground (F.G.) terminal as the sensor is not equipped with reverse polarity circuit protection (provided in UZJ1□□ only) or output short-circuit protection.

Precaution must be taken when the sensor is used in an electrically noisy place.

If the sensor is placed near a device which emits a large surge, such as a motor, solenoid or magnetic valve, etc., use a surge absorber.

Power supply should be turned off before wiring.

Verify that voltage fluctuations do not exceed the rated value.

When using a switching regulator power supply (readily available in the market), always ground the frame ground (F.G.) terminal.

When using equipment which generates noise (switching regulator or inverter motor, etc.) near the sensor, ground the frame ground (F.G.) terminal of the equipment.

Do not run sensor cables near high-voltage lines or power lines, nor put them together in the same raceway. Doing so may cause malfunctions due to inductive interference.

Others

Do not use the sensor output signal for 50ms immediately after the power is supplied to the sensor.

The sensor must not be directly exposed to organic solvents.

Do not use the sensor where it may be exposed to steam or dusts, or immersed in water.

Avoid places where the sensor may be directly exposed to fluorescent lights with rapid-starters or high frequency lighting as it may affect the sensing performance.

UZJ1□□

Setting

The optimum setting distance (central sensing distance) is 5mm (0.197inch).

The sensor will ignore specular backgrounds more than 30mm (1.181inch) away.

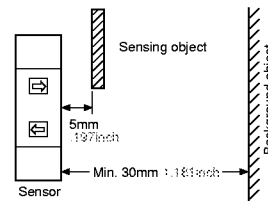

Wiring

Use a cable of over 0.3mm² and 2m (6.56ft) in length. If the cable is shorter than 2m (6.56ft), attach a capacitor of approx. 10μF between +V and 0V terminals.

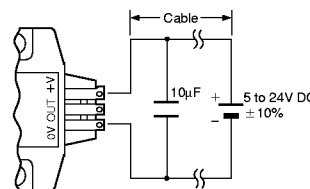

UZJ2□□

Others

Sensor is designed to be built in the machine and has no special ambient light counter-measure.

Be sure to avoid any direct ambient light.

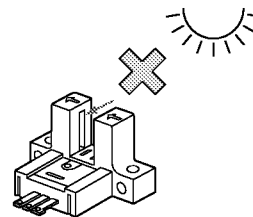

DIMENSIONS (Unit: mm Inch)

UZJ101
UZJ102 Sensor

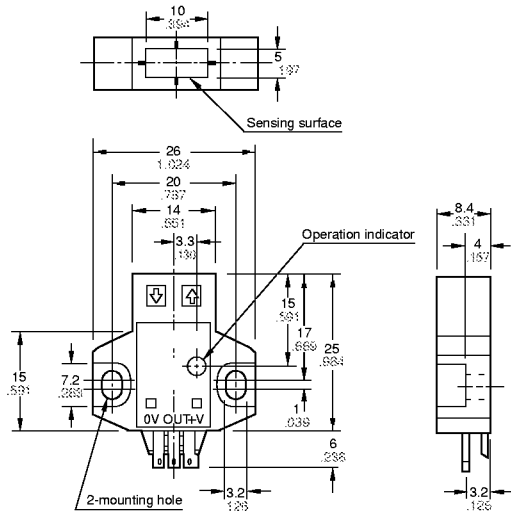

UZJ111
UZJ112 Sensor

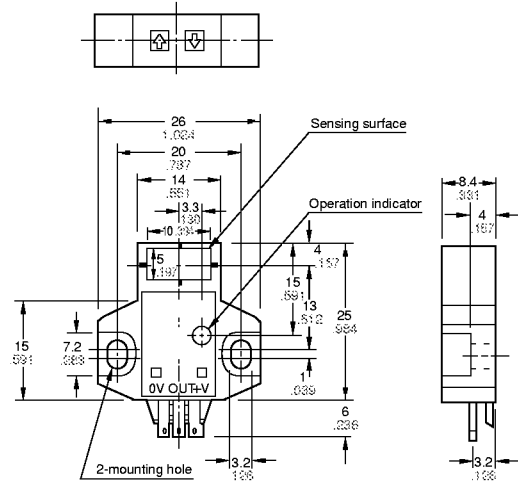

UZJ121
UZJ122 Sensor

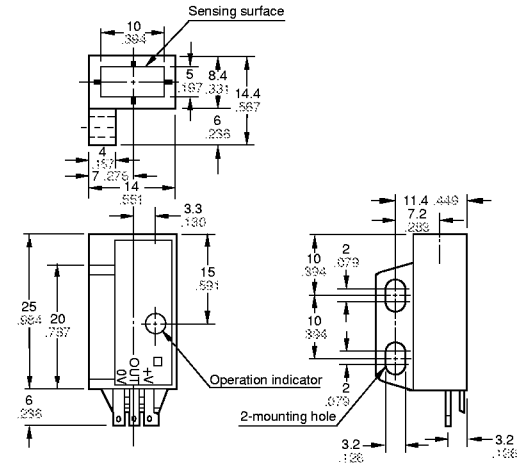

UZJ251
UZJ252 Sensor

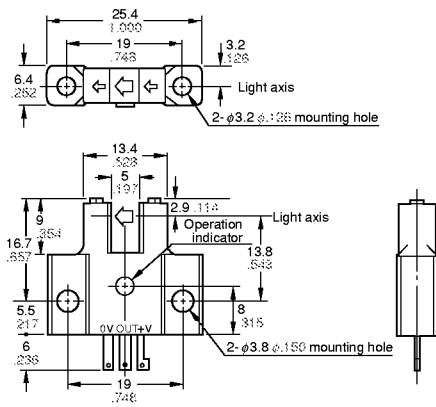

UZJ261
UZJ262 Sensor

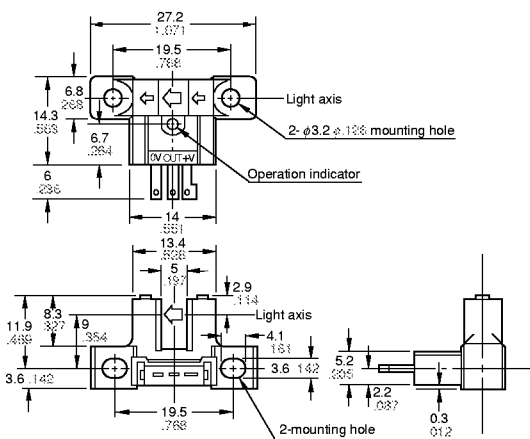

UZJ271
UZJ272 Sensor

