

ADVANCE INFORMATION

HAL700

Dual Hall-Effect Sensor with Independent Outputs

Contents

Page	Section	Title
3	1.	Introduction
3	1.1.	Features
3	1.2.	Applications
4	1.3.	Marking Code
4	1.3.1.	Special Marking of Prototype Parts
4	1.4.	Operating Junction Temperature Range
4	1.5.	Hall Sensor Package Codes
4	1.6.	Solderability
5	2.	Functional Description
6	3.	Specifications
6	3.1.	Outline Dimensions
6	3.2.	Dimensions of Sensitive Areas
6	3.3.	Positions of Sensitive Areas
7	3.4.	Absolute Maximum Ratings
7	3.5.	Recommended Operating Conditions
8	3.6.	Electrical Characteristics
9	3.7.	Magnetic Characteristics
9	3.7.1.	Magnetic Threshold
9	3.7.2.	Matching of B_{S1} and B_{S2}
9	3.7.3.	Hysteresis Matching
10	4.	Application Notes
10	4.1.	Ambient Temperature
10	4.2.	Extended Operating Conditions
10	4.2.1.	Supply voltage below 3.8 V
10	4.3.	Start-up Behavior
10	4.4.	EMC and ESD
12	5.	Data Sheet History

Dual Hall-Effect Sensor with Independent Outputs

1. Introduction

The HAL 700 is a monolithic CMOS Hall-effect sensor consisting of two independent latched switches (see Fig. 3–3) with closely matched magnetic characteristics controlling two independent open-drain outputs. The Hall plates of the two switches are spaced 2.35 mm apart.

In combination with an active target providing a sequence of alternating magnetic north and south poles, the sensor forms a system generating the signals required to control position, speed, and direction of the target movement.

The device includes temperature compensation and active offset compensation to provide excellent stability and matching of the switching points in the presence of mechanical stress over the whole temperature- and supply voltage range. This is required by systems which determine the direction by comparing two transducer signals.

The sensor is designed for industrial and automotive applications and operates with supply voltages from 3.8 V to 24 V in the ambient temperature range from $-40\text{ }^{\circ}\text{C}$ up to $125\text{ }^{\circ}\text{C}$.

The HAL 700 is available in the SMD package SOT-89B.

1.1. Features

- two independent Hall-switches
- distance of Hall plates: 2.35 mm
- low sensitivity
- typical B_{ON} : 14.9 mT at room temperature
- typical B_{OFF} : -14.9 mT at room temperature
- temperature coefficient of -2000 ppm/K in all magnetic characteristics
- switching offset compensation at typically 150 kHz
- operation from 3.8 V to 24 V supply voltage
- operation with static and dynamic magnetic fields up to 10 kHz
- overvoltage protection at all pins
- reverse-voltage protection at V_{DD} -pin
- robustness of magnetic characteristics against mechanical stress
- short-circuit protected open-drain outputs by thermal shutdown
- constant switching points over a wide supply voltage range
- EMC corresponding to DIN 40839

1.2. Applications

The HAL 700 is the ideal sensor for position-control applications with direction detection and alternating magnetic signals such as:

- multipole magnet applications,
- rotating speed and direction measurement, position tracking (active targets), and
- window lifters.

1.3. Marking Code

All Hall sensors have a marking on the package surface (branded side). This marking includes the name of the sensor and the temperature range.

Type	Temperature Range	
	K	E
HAL 700	700K	700E

1.3.1. Special Marking of Prototype Parts

Prototype parts are coded with an underscore beneath the temperature range letter on each IC. They may be used for lab experiments and design-ins but are not intended to be used for qualification test or as production parts.

1.4. Operating Junction Temperature Range

The Hall sensors from Micronas are specified to the chip temperature (junction temperature T_J).

K: $T_J = -40\text{ °C}$ to $+140\text{ °C}$

E: $T_J = -40\text{ °C}$ to $+100\text{ °C}$

The relationship between ambient temperature (T_A) and junction temperature is explained in Section 4.1. on page 10.

1.5. Hall Sensor Package Codes

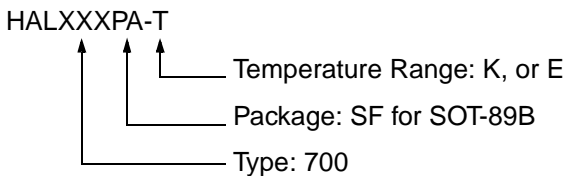

Example: **HAL 700SF-K**

- Type: 700
- Package: SOT-89B
- Temperature Range: $T_J = -40\text{ °C}$ to $+140\text{ °C}$

Hall sensors are available in a wide variety of packaging quantities. For more detailed information, please refer to the brochure: “Ordering Codes for Hall Sensors”.

1.6. Solderability

All packages: according to IEC68-2-58

During soldering, reflow processing, and manual reworking, a component body temperature of 260 °C should not be exceeded.

Components stored in the original packaging should provide a shelf life of at least 12 months, starting from the date code printed on the labels, even in environments as extreme as 40 °C and 90% relative humidity.

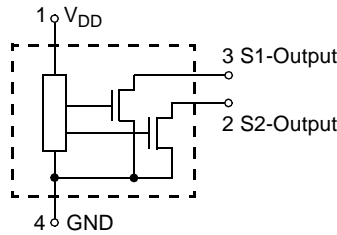

Fig. 1-1: Pin configuration

2. Functional Description

The HAL 700 is a monolithic integrated circuit with two independent subblocks consisting each of a Hall plate and the corresponding comparator. Each subblock independently switches the comparator output in response to the magnetic field at the location of the corresponding sensitive area. If a magnetic field with flux lines perpendicular to the sensitive area is present, the biased Hall plate generates a Hall voltage proportional to this field. The Hall voltage is compared with the actual threshold level in the comparator. The subblocks are designed to have closely matched switching points. The output of comparator 1 attached to S1 controls the open drain output at Pin 3. Pin 2 is set according to the state of comparator 2 connected to S2.

The temperature-dependent bias – common to both subblocks – increases the supply voltage of the Hall plates and adjusts the switching points to the decreasing induction of magnets at higher temperatures. If the magnetic field exceeds the threshold levels, the comparator switches to the appropriate state. The built-in hysteresis prevents oscillations of the outputs.

In order to achieve good matching of the switching points of both subblocks, the magnetic offset caused by mechanical stress is compensated for by use of “switching offset compensation techniques”. Therefore, an internal oscillator provides a two-phase clock to both subblocks. For each subblock, the Hall voltage is sampled at the end of the first phase. At the end of the second phase, both sampled and actual Hall voltages are averaged and compared with the actual switching point.

Shunt protection devices clamp voltage peaks at the Output-pins and V_{DD} -pin together with external series resistors. Reverse current is limited at the V_{DD} -pin by

an internal series resistor up to -15 V. No external reverse protection diode is needed at the V_{DD} -pin for reverse voltages ranging from 0 V to -15 V.

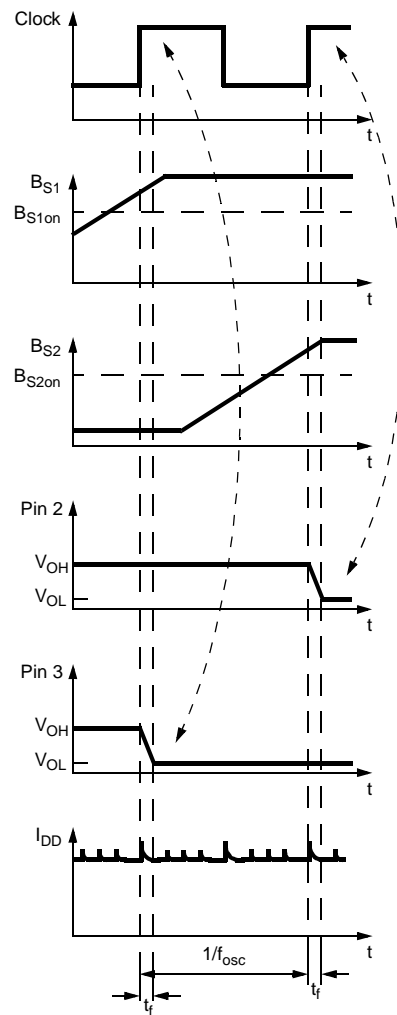

Fig. 2-1: Timing diagram

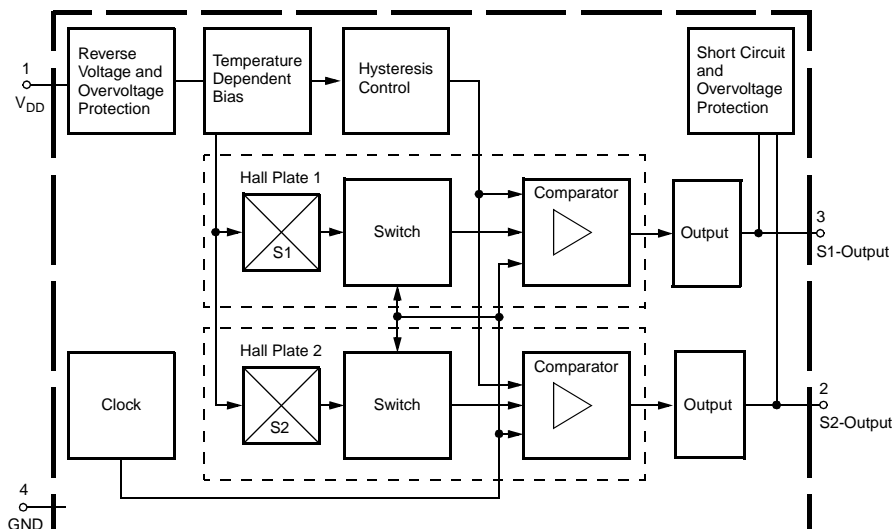

Fig. 2-2: HAL 700 block diagram

3. Specifications

3.1. Outline Dimensions

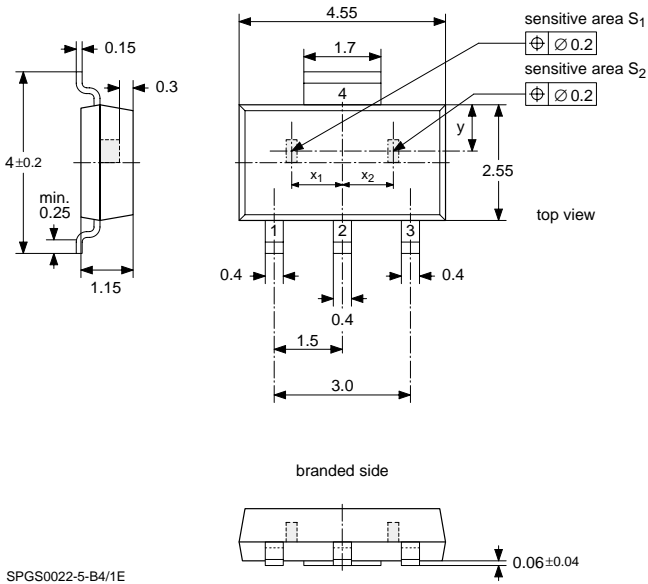

Fig. 3–1:
 Plastic Small Outline Transistor Package
(SOT-89B)
 Weight approximately 0.035 g
 Dimensions in mm

3.2. Dimensions of Sensitive Areas

Dimensions: 0.25 mm × 0.12 mm

3.3. Positions of Sensitive Areas

	SOT-89B
x_1+x_2	(2.35±0.001) mm
$x_1=x_2$	1.175 mm nominal
y	0.975 mm nominal

Note: For all package diagrams, a mechanical tolerance of ±0.05 mm applies to all dimensions where no tolerance is explicitly given.

3.4. Absolute Maximum Ratings

Symbol	Parameter	Pin No.	Min.	Max.	Unit
V_{DD}	Supply Voltage	1	-15	28 ¹⁾	V
$-V_P$	Supply Voltage	1	-24 ²⁾	28 ¹⁾	V
$-I_{DD}$	Reverse Supply Current	1	-	50 ¹⁾	mA
I_{DDZ}	Supply Current through Protection Device	1	-100 ³⁾	100 ³⁾	mA
V_O	Output Voltage	2, 3	-0.3	28 ¹⁾	V
I_O	Continuous Output On Current	2, 3	-	20 ¹⁾	mA
I_{Omax}	Peak Output On Current	2, 3	-	150 ³⁾	mA
I_{OZ}	Output Current through Protection Device	3	-200 ³⁾	200 ³⁾	mA
T_S	Storage Temperature Range		-65	150 ⁵⁾	°C
T_J	Junction Temperature Range		-40 -40	170 ⁴⁾ 150	°C °C

1) as long, as T_{Jmax} is not exceeded

2) with a 220-Ω series resistance at pin 1 corresponding to test circuit 1

3) $t < 2$ ms

4) $t < 1000$ h

5) Components stored in the original packaging should provide a shelf life of at least 12 months, starting from the date code printed on the labels, even in environments as extreme as 40 °C and 90% relative humidity.

Stresses beyond those listed in the “Absolute Maximum Ratings” may cause permanent damage to the device. This is a stress rating only. Functional operation of the device at these or any other conditions beyond those indicated in the “Recommended Operating Conditions/Characteristics” of this specification is not implied. Exposure to absolute maximum ratings conditions for extended periods may affect device reliability.

3.5. Recommended Operating Conditions

Symbol	Parameter	Pin No.	Min.	Typ.	Max.	Unit
V_{DD}	Supply Voltage	1	3.8	-	24	V
I_O	Continuous Output Current	3	0	-	10	mA
V_O	Output Voltage (output switch off)	3	0	-	24	V

3.6. Electrical Characteristics

at $T_J = -40\text{ }^\circ\text{C}$ to $+140\text{ }^\circ\text{C}$, $V_{DD} = 3.8\text{ V}$ to 24 V , as not otherwise specified in Conditions.
 Typical Characteristics for $T_J = 25\text{ }^\circ\text{C}$ and $V_{DD} = 5\text{ V}$.

Symbol	Parameter	Pin No.	Min.	Typ.	Max.	Unit	Conditions
I_{DD}	Supply Current	1	2	5.5	9	mA	$T_J = 25\text{ }^\circ\text{C}$
I_{DD}	Supply Current over Temperature Range	1		7	10	mA	
V_{DDZ}	Overvoltage Protection at Supply	1		28.5	32	V	$I_{DD} = 25\text{ mA}$, $T_J = 25\text{ }^\circ\text{C}$, $t = 20\text{ ms}$
V_{OZ}	Overvoltage Protection at Output	2, 3		28	32	V	$I_{OH} = 25\text{ mA}$, $T_J = 25\text{ }^\circ\text{C}$, $t = 20\text{ ms}$
V_{OL}	Output Voltage	2, 3		130	280	mV	$I_{OL} = 10\text{ mA}$, $T_J = 25\text{ }^\circ\text{C}$
V_{OL}	Output Voltage over Temperature Range	2, 3		130	400	mV	$I_{OL} = 10\text{ mA}$,
I_{OH}	Output Leakage Current	2, 3		0.06	0.1	μA	Output switched off, $T_J = 25\text{ }^\circ\text{C}$, $V_{OH} = 3.8\text{ V}$ to 24 V
I_{OH}	Output Leakage Current over Temperature Range	2, 3		–	10	μA	Output switched off, $T_J \leq 140\text{ }^\circ\text{C}$, $V_{OH} = 3.8\text{ V}$ to 24 V
f_{osc}	Internal sampling frequency	–	130	150	–	kHz	$T_J = 25\text{ }^\circ\text{C}$
f_{osc}	Internal sampling frequency over Temperature Range	–	100	150	–	kHz	
$t_{en}(O)$	Enable Time of Output after Setting of V_{DD}			50	100	μs	$V_{DD} = 12\text{ V}$, $B > B_{on} + 2\text{ mT}$ or $B < B_{off} - 2\text{ mT}$
t_r	Output Rise Time	2, 3		1.2		μs	$V_{DD} = 12\text{ V}$, $R_L = 20\text{ k}\Omega$, $C_L = 20\text{ pF}$
t_f	Output FallTime	2, 3		0.2	1.6	μs	$V_{DD} = 12\text{ V}$, $R_L = 20\text{ k}\Omega$, $C_L = 20\text{ pF}$
R_{thSB} SOT-89B	Thermal Resistance Junction to Substrate Backside	–	–	150	200	K/W	Fiberglass Substrate 30 mm x 10mm x 1.5mm, pad size see Fig. 3–2

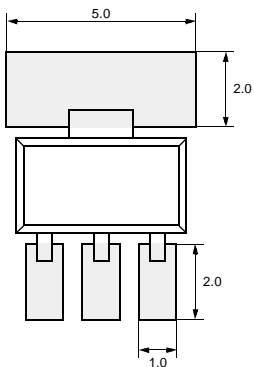

Fig. 3–2: Recommended pad sizes for SOT-89B
 Dimensions in mm

3.7. Magnetic Characteristics

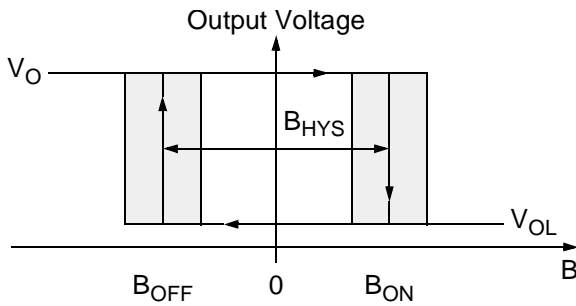

Fig. 3–3: Definition of magnetic switching points for the HAL 700

Positive flux density values refer to the magnetic south pole at the branded side of the package.

3.7.1. Magnetic Threshold

(quasistationary: $dB/dt < 0.5 \text{ mT/ms}$)

at $T_J = -40 \text{ }^\circ\text{C}$ to $+140 \text{ }^\circ\text{C}$, $V_{DD} = 3.8 \text{ V}$ to 24 V , as not otherwise specified

Typical Characteristics for $T_J = 25 \text{ }^\circ\text{C}$ and $V_{DD} = 5 \text{ V}$

Parameter	On point B_{S1on}, B_{S2on}			Off point B_{S1off}, B_{S2off}			Unit
	Min.	Typ.	Max.	Min.	Typ.	Max.	
T_J							
$-40 \text{ }^\circ\text{C}$	12.5	16.3	20	-20	-16.3	-12.5	mT
$25 \text{ }^\circ\text{C}$	10.7	14.9	19.1	-19.1	-14.9	-10.7	mT
$100 \text{ }^\circ\text{C}$	tbd	tbd	tbd	tbd	tbd	tbd	mT
$140 \text{ }^\circ\text{C}$	6.0	10.9	16.0	-16.0	-10.9	-6.0	mT

3.7.2. Matching of B_{S1} and B_{S2}

(quasistationary: $dB/dt < 0.5 \text{ mT/ms}$)

at $T_J = -40 \text{ }^\circ\text{C}$ to $+140 \text{ }^\circ\text{C}$, $V_{DD} = 3.8 \text{ V}$ to 24 V , as not otherwise specified

Typical Characteristics for $T_J = 25 \text{ }^\circ\text{C}$ and $V_{DD} = 5 \text{ V}$

Parameter	$B_{S1on} - B_{S2on}$			$B_{S1off} - B_{S2off}$			Unit
	Min.	Typ.	Max.	Min.	Typ.	Max.	
T_J							
$-40 \text{ }^\circ\text{C}$	-7.5	0	7.5	-7.5	0	7.5	mT
$25 \text{ }^\circ\text{C}$	-7.5	0	7.5	-7.5	0	7.5	mT
$100 \text{ }^\circ\text{C}$	-7.5	0	7.5	-7.5	0	7.5	mT
$140 \text{ }^\circ\text{C}$	-7.5	0	7.5	-7.5	0	7.5	mT

3.7.3. Hysteresis Matching

(quasistationary: $dB/dt < 0.5 \text{ mT/ms}$)

at $T_J = -40 \text{ }^\circ\text{C}$ to $+140 \text{ }^\circ\text{C}$, $V_{DD} = 3.8 \text{ V}$ to 24 V , as not otherwise specified

Typical Characteristics for $T_J = 25 \text{ }^\circ\text{C}$ and $V_{DD} = 5 \text{ V}$

Parameter	$(B_{S1on} - B_{S1off}) / (B_{S2on} - B_{S2off})$			Unit
T_J	Min.	Typ.	Max.	
T_J				
$-40 \text{ }^\circ\text{C}$	0.85	1.0	1.2	-
$25 \text{ }^\circ\text{C}$	0.85	1.0	1.2	-
$100 \text{ }^\circ\text{C}$	0.85	1.0	1.2	-
$140 \text{ }^\circ\text{C}$	0.85	1.0	1.2	-

4. Application Notes

4.1. Ambient Temperature

Due to the internal power dissipation, the temperature on the silicon chip (junction temperature T_J) is higher than the temperature outside the package (ambient temperature T_A).

$$T_J = T_A + \Delta T$$

At static conditions, the following equation is valid:

$$\Delta T = I_{DD} * V_{DD} * R_{th}$$

For typical values, use the typical parameters. For worst case calculation, use the max. parameters for I_{DD} and R_{th} , and the max. value for V_{DD} from the application.

For all sensors, the junction temperature range T_J is specified. The maximum ambient temperature T_{Amax} can be calculated as:

$$T_{Amax} = T_{Jmax} - \Delta T$$

4.2. Extended Operating Conditions

All sensors fulfil the electrical and magnetic characteristics when operated within the Recommended Operating Conditions (see page 7)

Supply Voltage Below 3.8 V

Typically, the sensors operate with supply voltages above 3 V, however, below 3.8 V some characteristics may be outside the specification.

Note: The functionality of the sensor below 3.8 V is not tested. For special test conditions, please contact Micronas.

4.3. Start-up Behavior

Due to the active offset compensation, the sensors have an initialization time (enable time $t_{en(O)}$) after applying the supply voltage. The parameter $t_{en(O)}$ is specified in the Electrical Characteristics (see page 8)

During initialization time, the output states are not defined and the outputs can toggle. After $t_{en(O)}$ both outputs will be either high or low for a stable magnetic field (no toggling). The outputs will be low if the applied magnetic flux density B exceeds B_{ON} and high if B drops below B_{OFF}

For magnetic fields between B_{OFF} and B_{ON} , the output states of the Hall sensor after applying V_{DD} will be either low or high. In order to achieve a well-defined output state, the applied magnetic flux density must be above B_{ONmax} , respectively, below B_{OFFmin} .

4.4. EMC and ESD

For applications that cause disturbances on the supply line or radiated disturbances, a series resistor and a capacitor are recommended (see Fig. 4–1). The series resistor and the capacitor should be placed as closely as possible to the Hall sensor.

Please contact Micronas for detailed investigation reports with EMC and ESD results.

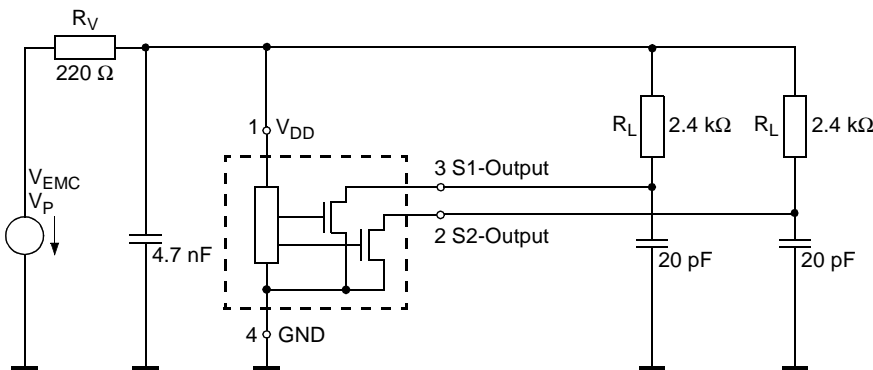

Fig. 4–1: Test circuit for EMC investigations

5. Data Sheet History

1. Advance Information: "HAL700 Dual Hall-Effect Sensor with Independent Outputs", Feb. 20, 2001, 6251-477-1AI. First release of the advance information.

Micronas GmbH
Hans-Bunte-Strasse 19
D-79108 Freiburg (Germany)
P.O. Box 840
D-79008 Freiburg (Germany)
Tel. +49-761-517-0
Fax +49-761-517-2174
E-mail: docservice@micronas.com
Internet: www.micronas.com

Printed in Germany
Order No. 6251-477-1AI

All information and data contained in this data sheet are without any commitment, are not to be considered as an offer for conclusion of a contract, nor shall they be construed as to create any liability. Any new issue of this data sheet invalidates previous issues. Product availability and delivery are exclusively subject to our respective order confirmation form; the same applies to orders based on development samples delivered. By this publication, Micronas GmbH does not assume responsibility for patent infringements or other rights of third parties which may result from its use.

Further, Micronas GmbH reserves the right to revise this publication and to make changes to its content, at any time, without obligation to notify any person or entity of such revisions or changes.

No part of this publication may be reproduced, photocopied, stored on a retrieval system, or transmitted without the express written consent of Micronas GmbH.