

- NOTES:
- MATERIAL:
    - HOUSING: THERMOPLASTIC, HIGH TEMP., UL94V-0; COLOR:BLACK.
    - CONTACT: COPPER ALLOY
    - FITTING NAIL: COPPER ALLOY
  - FINISH:
    - CONTACT: GOLD FLASH PLATING OVERALL(1~3u) . 50~100u" NICKEL UNDERPLATING OVERALL.
    - FITTING NAIL: 100~200u" MATT TIN PLATING ON SOLDER TAILS. 50~100u" NICKEL UNDERPLATING OVERALL.
  - REFLOW SOLDER CAPABLE TO 260°C PER ACES SPEC.
  - SPEC. PLS. REFER TO PS-50007-xxxx-xxx
  - PACKAGE PLS. REFER TO 88660-XXX-TRP(WITHOUT BOSS) 88660-XXXB-TRP(WITH BOSS)
  - PART NUMBER

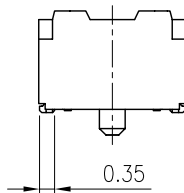
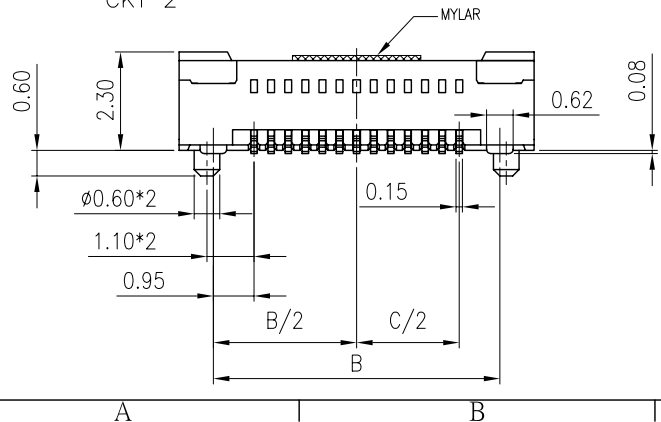
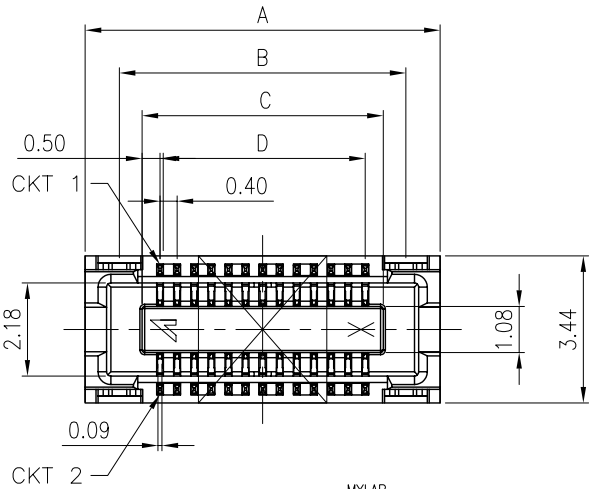

50012-XXX X X-XXX

XXX	Housing Color	Halogen Free	Polarization
001	Black	HF	with boss
002	Black	HF	without boss

- PLATING  
1: GOLD FLASH OVER ALL
- PACKING  
0: TAPE & REEL  
1: TUBE PACKAGE  
4: TAPE & REEL WITH MYLAR  
5: TUBE PACKAGE WITH MYLAR
- No Of CKT

CKT	Dim A	Dim B	Dim C	Dim D
10	5.10	3.50	2.44	1.60
14	5.90	4.30	3.24	2.40
20	7.10	5.50	4.44	3.60
22	7.50	5.90	4.84	4.00
24	7.90	6.30	5.24	4.40
26	8.30	6.70	5.64	4.80
30	9.10	7.50	6.44	5.60
40	11.10	9.50	8.44	7.60
50	13.10	11.50	10.44	9.60
60	15.10	13.50	12.44	11.60
70	17.10	15.50	14.44	13.60
80	19.10	17.50	16.44	15.60
90	21.10	19.50	18.44	17.60
100	23.10	21.50	20.44	19.60
120	27.10	25.50	24.44	23.60

一般公差 <b>TOLERANCES</b> X ±0.5 XX ±0.15 X ±0.25 XXX ±0.1 ANGLES ±2°		<b>宏致電子股份有限公司</b> Aces Electronic Co.,Ltd.	
檢驗尺寸標示 <b>SYMBOLS</b> ⊕ ⊗ INDICATE CLASSIFICATION DIMENSION ⊕ MARK IS CRITICAL DIM. ⊗ MARK IS MAJOR DIM.	品名 (TITLE) 0.4mm BTB D/R RCPT SMT S/T TYPE 圖號 (DWG.NO) <b>50012-XXXXX-XXX</b>	製圖 (DR) 08/12/01 Even 審核 (CHKD) WGCH 核准 (APPD) Jason.C	表面處理 (FINISH) 比例 (SCALE) 單位 (UNITS) 6:1 mm
0 NEW DRAWING 日期 08/12/01 簽名 Even	張數 (SHEET) 1 OF 1 SIZE A4 REV 0		

REV	REVISION DESCRIPTION	DATE	SIGNATURE
0	NEW DRAWING	08/12/01	Even