

STRATUM 3E High Stability Oven Stabilized Oscillator OH300 Series

OCXO - OCVCO

**CONNOR
WINFIELD**



2111 Comprehensive Drive
Aurora, Illinois 60505
Phone: 630-851-4722
Fax: 630-851-5040
www.conwin.com
US Headquarters:
630-851-4722
European Headquarters:
+353-61-472221

Description

Connor-Winfield's high stability OH300 OCXO / OCVCO series are exceptionally precise frequency standard, excellent for use in cellular base stations, test equipment, Synchronous Ethernet, VSAT and Stratum 3E applications

These unique OCXOs and OCVCOs provide frequency stabilities in the range of ± 10 ppb to ± 50 ppb, over the commercial, extended commercial or the industrial temperature range. Power requirements are 1.1W over the commercial temperature range and 1.5W over the industrial temperature range after warm-up. Additionally, excellent aging is achieved through the use of overtone SC cut crystals.

The OH300 series is available with CMOS logic or Sinewave output along with Electronic Frequency Tuning. These oscillators provide outstanding phase noise that varies depending on frequency requirements. Allan Variance specifications are rated for primary reference standards. Warm up times are on the order of 5 minutes to 0.10 ppm of final frequency.

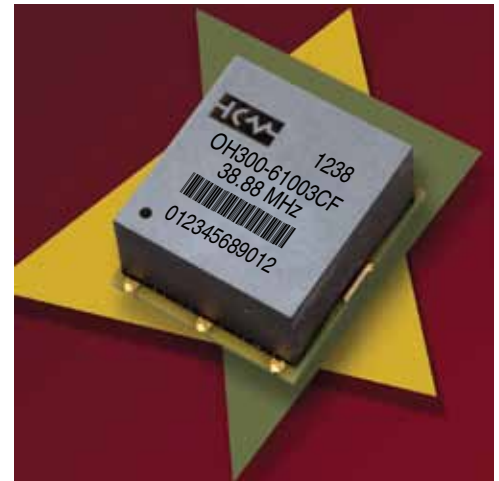

Features

- Frequency Range: 5 to 40 MHz
- OCXO - Fixed Frequency
- OCVCO - Voltage Controlled Frequency
- 3.3 Vdc or 5.0 Vdc Operation
- Available Frequency Stabilities:
 ± 10.0 ppb, ± 20 ppb or ± 50 ppb
- Available Temperature Ranges:
0 to 70°C, -20 to 70°C, -20 to 75°C,
-40 to 70°C or -40 to 85°C
- Low Phase Noise / Phase Jitter
- Output: CMOS Logic or Sinewave
- SMT Package: 22 mm x 25 mm x 12.7 mm
- RoHS Compliant / Lead Free

Ordering Information

| OH300- | 6 | 10 | 03 | C | F | - 038.88M |
|---|---|---|--|---|---|--|
| Package OH300- = 22x25mm Surface Mount Package | Temperature Range 5 = 0 to 70°C 6 = -40 to 85°C 7 = -20 to 70°C 8 = -40 to 70°C 9 = -20 to 75°C | Frequency Stability 10 = ± 10.0 ppb 20 = ± 20.0 ppb 50 = ± 50.0 ppb | Supply Voltage 03 = 3.3 Vdc 05 = 5.0 Vdc | Output Type C = CMOS S = Sinewave | OCXO Type F = Fixed Freq. V = Voltage Controlled Freq. | Output Frequency Frequency Format -xxx.xM Min -xxx.xxxxxM Max *Amount of numbers after the decimal point. M = MHz |

Example Part Number:

OH300-61003CF-038.88M = 22x25x12.7mm SMT package, -40 to 85°C temperature range, ± 10.0 ppb frequency stability, 3.3 Vdc supply voltage, CMOS square wave output, fixed output frequency OCXO, 38.88 MHz output frequency.

OH300-52005CV-010.0M = 22x25x12.7mm SMT package, 0 to 70°C temperature range, ± 20.0 ppb frequency stability, 5.0 Vdc supply voltage, CMOS square wave output, voltage controlled output frequency, OCVCO, 10.0 MHz output frequency.

OH300-75005SV-020.0M = 22x25x12.7mm SMT package, -20 to 70°C temperature range, ± 50.0 ppb frequency stability, 5.0 Vdc supply voltage, Sinewave output, voltage controlled output frequency, OCVCO, 20.0 MHz output frequency.



Bulletin **Cx210**
Page **1 of 5**
Revision **09**
Date **14 Nov 2012**



*Attention: System Designers please review Application Note AN2093:
System Design Information and Printed Circuit Board Layout Guidelines for OCXO Oscillators.
@ www.conwin.com/technologies.html*



Absolute Maximum Ratings

| Parameter | Minimum | Nominal | Maximum | Units | Notes |
|--------------------------------|---------|---------|---------|-------|-------|
| Storage Temperature | -55 | - | 125 | °C | |
| Supply Voltage - 3.3 Vdc (Vcc) | -0.5 | - | 4.5 | Vdc | |
| Supply Voltage - 5.0 Vdc (Vcc) | -0.5 | - | 7.0 | Vdc | |
| Control Voltage (Vc) | -0.5 | - | 7.0 | Vdc | |

Operating Specifications

| Parameter | Minimum | Nominal | Maximum | Units | Notes |
|--|---------|---------|---------|---------|--------|
| Center Frequency: (Fo) | 5 | - | 40 | MHz | |
| Operating Temperature Range: | | | | | |
| Temperature Code 5 | 0 | - | 70 | °C | |
| Temperature Code 6 | -40 | - | 85 | °C | |
| Temperature Code 7 | -20 | - | 70 | °C | |
| Temperature Code 8 | -40 | - | 70 | °C | |
| Temperature Code 9 | -20 | - | 75 | °C | |
| Frequency Calibration: | -0.1 | - | 0.1 | ppm | @ 25°C |
| Frequency Stability vs. Change in Temperature: | | | | | |
| Stability Code 10 | -10.0 | - | 10.0 | ppb | 1 |
| Stability Code 20 | -20.0 | - | 20.0 | ppb | 1 |
| Stability Code 50 | -50.0 | - | 50.0 | ppb | 1 |
| Frequency Stability vs Load | -2.0 | - | 2.0 | ppb | ±5% |
| Frequency Stability vs Voltage | -2.0 | - | 2.0 | ppb | ±5% |
| Aging: Daily: | | | | | |
| 5 MHz to 20 MHz | -1.0 | - | 1.0 | ppb/day | 2 |
| >20 MHz to 40 MHz | -2.0 | - | 2.0 | ppb/day | 2 |
| Aging: First Year: | | | | | |
| 5 MHz to 20 MHz | -50 | - | 50 | ppb | |
| >20 MHz to 40 MHz | -100 | - | 100 | ppb | |
| Lifetime Tolerance: (20 Years) | | | | | |
| 5 MHz to 20 MHz | -300 | - | 300 | ppb | 3 |
| >20 MHz to 40 MHz | -500 | - | 500 | ppb | 3 |
| Supply Voltage: (Vcc) (Note: Power supply turn-on ramp time must be > 5 ms to 90% of Vcc.) | | | | | |
| Voltage Code 03 | 3.13 | 3.30 | 3.47 | Vdc | 4 |
| Voltage Code 05 | 4.75 | 5.00 | 5.25 | Vd | 4 |
| Power Consumption: Turn-On | | | | | |
| 0 to 70°C Models | - | - | 3.00 | W | 5 |
| -20 to 70°C Models | - | - | 3.20 | W | 5 |
| -20 to 75°C Models | - | - | 3.30 | W | 5 |
| -40 to 85°C Models | - | - | 3.80 | W | 5 |
| Power Consumption: Steady State @ 25°C | | | | | |
| 0 to 70°C Models | - | - | 1.10 | W | 5 |
| -20 to 70°C Models | - | - | 1.15 | W | 5 |
| -20 to 75°C Models | - | - | 1.20 | W | 5 |
| -40 to 85°C Models | - | - | 1.50 | W | 5 |
| Phase Jitter: (BW: 10 Hz to Fo/2) | - | - | 1.0 | ps rms | |
| Short Term Allan Deviation (1s) | - | 1.0E-11 | - | rms | |
| Start-Up Time: | - | - | 500 | ms | |
| Warm Up Time @ 25°C: | - | - | 5 | minutes | 6 |

Phase Noise Characteristics

Typical Phase Noise for 10 MHz OXCO's with CMOS Output

| Parameter | Minimum | Nominal | Maximum | Units | Notes |
|-----------------|---------|---------|---------|--------|-------|
| @1Hz offset | - | - | -85 | dBc/Hz | |
| @ 10Hz offset | - | - | -115 | dBc/Hz | |
| @ 100Hz offset | - | - | -140 | dBc/Hz | |
| @ 1KHz offset | - | - | -145 | dBc/Hz | |
| @ 10KHz offset | - | - | -150 | dBc/Hz | |
| @ 100KHz offset | - | - | -150 | dBc/Hz | |



OCVCXO Input Characteristics (OCXO Type Code V)

| Parameter | Minimum | Nominal | Maximum | Units | Notes |
|-----------------------------|---------|---------|---------|-------|-------|
| Control Voltage Range: (Vc) | | | | | |
| 3.3 Vdc Models | 0.30 | 1.65 | 3.00 | V | 7 |
| 5.0 Vdc Models | 0.50 | 2.50 | 4.50 | V | 7 |
| Frequency Pullability: | ±0.4 | - | - | ppm | |
| Input Impedance | 100K | - | - | Ohms | |

CMOS Output Characteristics (Output Code C)

| Parameter | Minimum | Nominal | Maximum | Units | Notes |
|------------------------------|---------|---------|---------|-------|-------|
| Load | - | 15 | - | pF | |
| Output Voltage: | | | | | |
| 3.3 Vdc Models | | | | | |
| High (Voh) | 3.0 | - | - | V | |
| Low (Vol) | - | - | 0.4 | | |
| 5.0 Vdc Models | | | | | |
| High (Voh) | 4.7 | - | - | V | |
| Low (Vol) | - | - | 0.4 | | |
| Duty Cycle at 50% of Vcc | 45 | 50 | 55 | % | |
| Rise / Fall Time: 10% to 90% | - | - | 6 | ns | |
| Spurious Output | - | - | -80 | dBc | |

Sinewave Output Characteristics (Output Code S)

| Parameter | Minimum | Nominal | Maximum | Units | Notes |
|--------------|---------|---------|---------|-------|-------|
| Load | - | 50 | - | Ohms | |
| Output Power | 5.0 | - | - | dBm: | |
| Harmonics | - | - | -30 | dBc | |
| Spurious | - | - | -80 | dBc | |

Package Characteristics

OH300 Package Package consisting of a FR4 substrate and Ryton-R4 cover. Water Resistant package, non-hermetic seal.

Recommended Cleaning Process

Wash only in a in-line high pressure wash station that has an air knife and drying capabilities.
(Drying temperature range from 85° to 100°C)

Environmental Characteristics

| | |
|----------------------|--|
| Shock | 500 G's 1ms, Halfsine, 3 shocks per direction, per MIL-STD 202G, Method 213B Test Condition D. |
| Sinusoidal Vibration | 0.06" D.A. or 10G's Peak, 10 to 500 Hz, per MIL-STD-202G, Method 204D, Test Condition A. |
| Random Vibration | 5.35 G's rms. 20 to 2000 Hz per MIL-STD-202G, Method 214, Test Condition 1A, 15 minutes each axis. |
| Moisture | 10 cycles, 95% RH, Per MIL-STD-202G, Method 112. |
| Marking Permanency | Per MIL-STD-202G, Method 215J. |
| Solder Process | RoHS compliant, lead free. See solder profile. |

Re-Stabilization Time

| Off Time | Re stabilization Time |
|--------------|---------------------------|
| <1 Hour | <2 Hours * |
| <6 Hour | <12 Hours * |
| <24 Hour | <48 Hours * |
| 1 to 16 Days | 48 Hours + 1/4 Off Time * |
| >16 Days | <6 Days * |

* For a given off time, the time required to meet daily aging, short term stability requirements.

Notes:

1. Referenced to the frequency measured @ 25°C. OCVCXO control voltage (Vc) = nominal voltage.
2. At time of shipment after 48 hours of operation.
3. Inclusive of calibration, operating temperature, supply voltage change, load change and 20 years aging.
4. Minimum "Power On Time" after rail rises from 0 to within +/-5% of Vcc = 1 second.
Vcc ramp rate must be <0.3 volts per millisecond.
5. Measured with Vcc = Nominal, in calm air.
6. Measured @ 25°C, within ± 100 ppb, referenced one hour after turn-on.
7. To ensure proper operation of OCVCXO's the control voltage input must be biased the nominal control voltage. Failure to bias the Vc input will cause an unstable output condition.

| | |
|----------|--------------------|
| Bulletin | Cx210 |
| Page | 3 of 5 |
| Revision | 09 |
| Date | 14 Nov 2012 |



Attention: System Designers please review Application Note AN2093:
System Design Information and Printed Circuit Board Layout Guidelines for OCXO Oscillators.
@ www.conwin.com/technologies.html

Package Outline

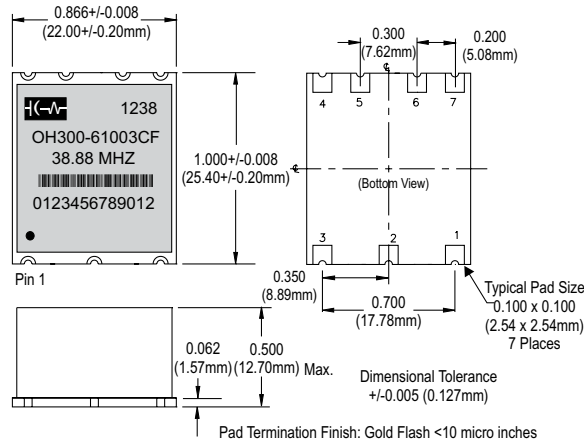

Marking Information

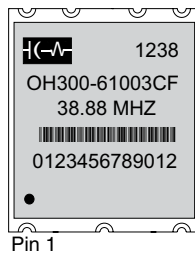

1238 Date Code (YYWW)
OH300-61003CF Model Number
38.88 MHz Output Frequency
0123456789012 Serial # Barcode
Serial Number

Suggested Pad Layout

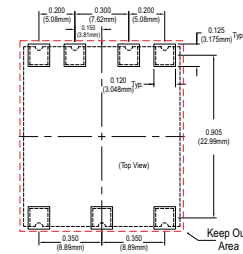

* Do not route any traces in the keep out area. It is recommended the next layer under the keep out area is to be ground plane.

Test Circuit CMOS Output

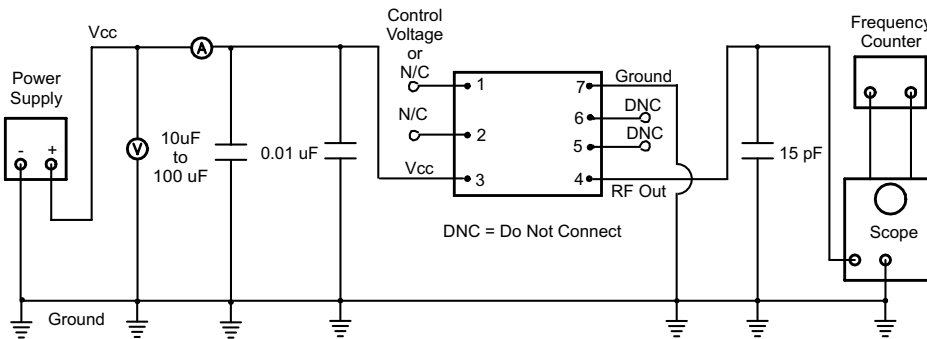

Pad Connections

- 1: Control Voltage or N/C
- 2: N/C
- 3: Supply Voltage (Vcc)
- 4: RF Output
- 5: Do Not Connect
- 6: Do Not Connect
- 7: Ground (Case)

Test Circuit Sinewave Output

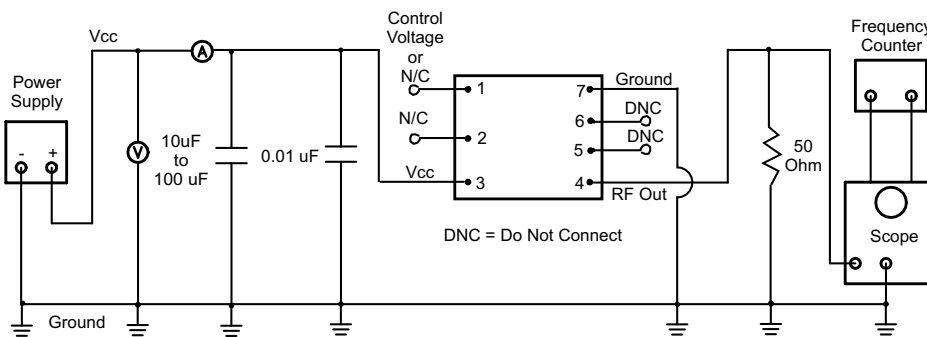

| | |
|----------|--------------------|
| Bulletin | Cx210 |
| Page | 4 of 5 |
| Revision | 09 |
| Date | 14 Nov 2012 |

CMOS Output Waveform

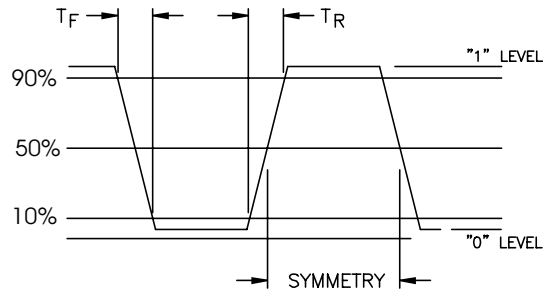

Solder Profile

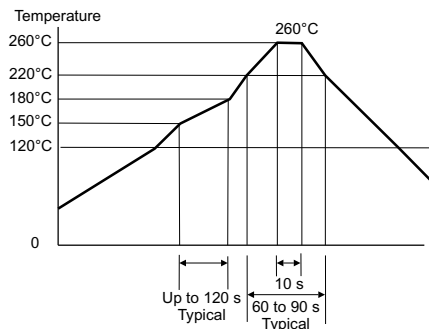

Meets IPC/JEDEC J-STD-020C

Tape and Reel Information

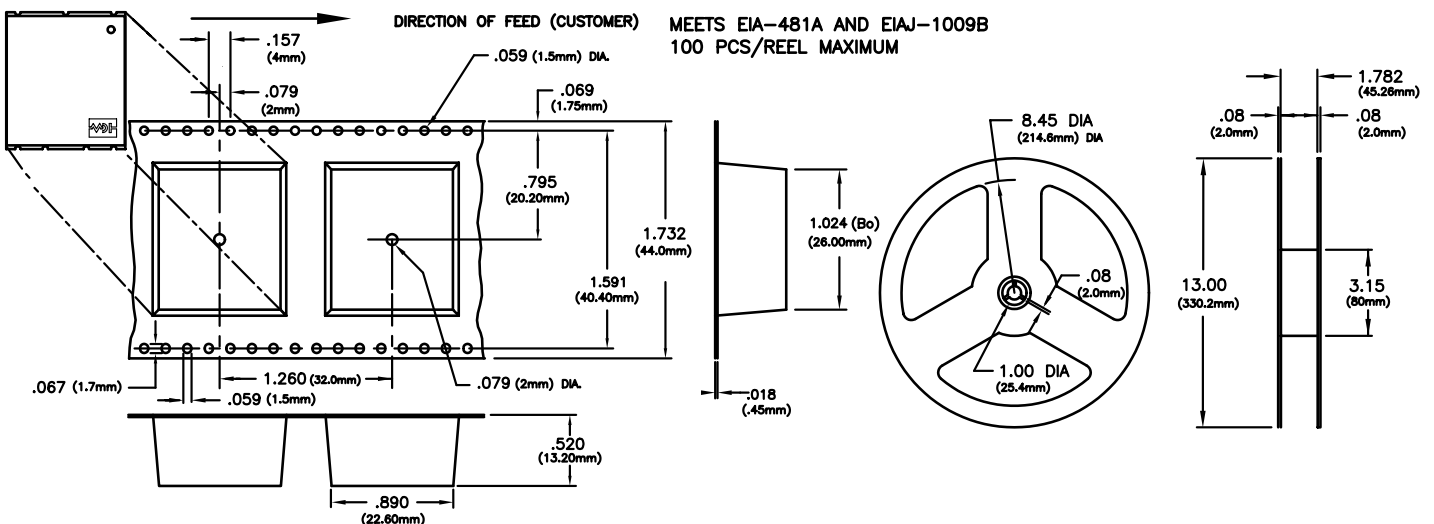

Rev P00, New issue. 01/26/11.

Rev P01, Added tape and reel information. 05/04/11.

Rev P02, Added OH300 Photo. 05/06/11.

Rev P03, updated the Description. 05/25/11.

Rev P04, Updated power consumption and changed package drawing. 07/27/11.

Rev P05, Added sinewave models to the data sheet 09/08/11.

Rev P06, added cleaning process and package characteristics. 08/09/12.

Rev 07, added Barcode to package marking. 09/27/12

Rev 08, Added link to Application Note: AN2093. 11/06/12

Rev 09, Added additional notes. 11/14/12.

| | |
|----------|--------------------|
| Bulletin | Cx210 |
| Page | 5 of 5 |
| Revision | 09 |
| Date | 14 Nov 2012 |