

Clock Oscillators (SMD)



K30-HC Series (5.0V)

K30 SERIES



DIMENSIONS

millimeters (inches)

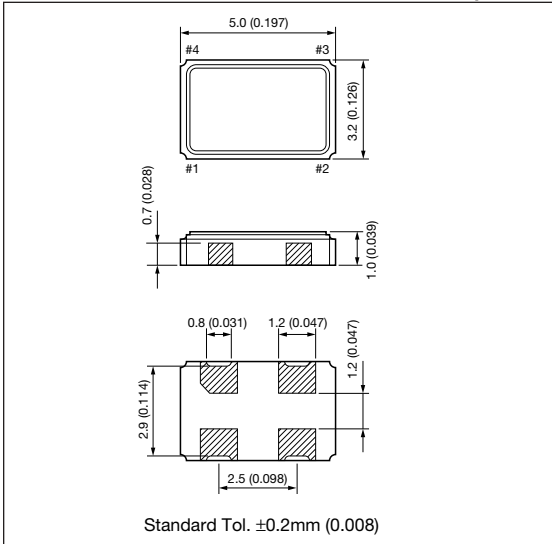

PIN CONNECTION

Pin #	Function
1	CONTROL
2	CASE GND
3	OUTPUT
4	+V _{CC}

ENABLE/DISABLE

Pin #1	Pin #3
"H" or Open	Oscillation
"L"	High Impedance

SPECIFICATIONS

Items	Code	Rating	Unit	Remarks
Output Frequency	F _{OUT}	8 to 50	MHz	—
Frequency Tolerance	$\Delta F/F$	$\pm 100, \pm 50$	ppm	Over all conditions
Aging	$\Delta F/F$	± 5	ppm/y	@ 25°C
Operating Temperature	T _{OPR}	-10 to 70	°C	—
Storage Temperature	T _{STR}	-55 to 125	°C	—
Supply Voltage	V _{CC}	5 \pm 0.5	V	—
Supply Current	I _{CC}	50 max.	mA	Loaded @ 50MHz
Disable Current	I _{DE}	30 max.	mA	—
Duty Ratio	SYM	45 to 55	%	0.5V _{CC} DC Level
Output 0 Level	V _{OL}	0.1V _{CC} max.	V	I _{OH} = 16mA
Output 1 Level	V _{OH}	0.9V _{CC} min.	V	I _{OH} = -16mA
Rise/Fall Time	T _R , T _F	10 max.	nsec	0.1V _{CC} -0.9V _{CC}
Load Capacitance	C _L	50 max.	pF	—
Enable/Disable Time	—	100 max.	nsec	—
Input Voltage Low	V _{IL}	0.8 max.	V	—
Input Voltage High	V _{IH}	2.2 min.	V	—
Start-up Time	ST	10 max.	mS	Minimum Operating Voltage to be 0sec

*Please contact us for inquiries about Extend Operating Temperature Range (-40 to +85°C), available frequencies, other condition.

FEATURES

- High reliable miniature SMD ceramic package
- Frequency range = 8MHz to 50MHz
- Frequency tolerance = $\pm 100\text{ppm}$, $\pm 50\text{ppm}$
- Tristate output inhibit

APPLICATIONS

- PDAs
- Portable electronics

HOW TO ORDER

K30 - HC 1 C S E 25.0000M R

Packaging

R = Tape and reel,
1,000 pcs/reel

Frequency (MHz)

14.31818	24.5760	30.0000
16.0000	25.0000	32.0000
17.7345	27.0000	33.8688
20.0000	28.37516	48.0000
24.0000	28.63636	—

Enable/Disable Function

E = with function (STD)

Duty Ratio

S = 45% to 55% (STD)

Output

C = CMOS/Compatibility

Tolerance

1 = $\pm 100\text{ppm}$
0 = $\pm 50\text{ppm}$

Series