

## TO-220 Plastic-Encapsulate Transistors

### 3DD13007N36 TRANSISTOR (NPN)

#### FEATURES

- Power switching applications

#### MAXIMUM RATINGS (T<sub>a</sub>=25°C unless otherwise noted)

Symbol	Parameter	Value	Unit
V <sub>CBO</sub>	Collector-Base Voltage	700	V
V <sub>CEO</sub>	Collector-Emitter Voltage	400	V
V <sub>EBO</sub>	Emitter-Base Voltage	9	V
I <sub>C</sub>	Collector Current -Continuous	8	A
P <sub>C</sub>	Collector Power Dissipation	2	W
T <sub>j</sub>	Junction Temperature	150	°C
T <sub>stg</sub>	Storage Temperature	-55~150	°C

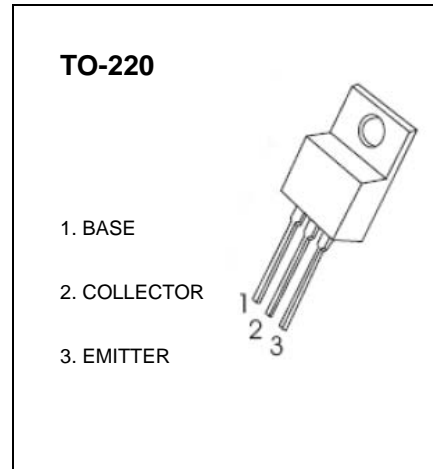

#### ELECTRICAL CHARACTERISTICS (T<sub>a</sub>=25°C unless otherwise specified)

Parameter	Symbol	Test conditions	Min	Typ	Max	Unit
Collector-base breakdown voltage	V <sub>(BR)CBO</sub>	I <sub>C</sub> = 1mA, I <sub>E</sub> =0	700			V
Collector-emitter breakdown voltage	V <sub>(BR)CEO</sub>	I <sub>C</sub> =10mA, I <sub>B</sub> =0	400			V
Emitter-base breakdown voltage	V <sub>(BR)EBO</sub>	I <sub>E</sub> =1mA, I <sub>C</sub> =0	9			V
Collector cut-off current	I <sub>CBO</sub>	V <sub>CB</sub> =700V, I <sub>E</sub> =0			100	μ A
Collector cut-off current	I <sub>CEO</sub>	V <sub>CE</sub> =400V, I <sub>B</sub> =0			100	μ A
Emitter cut-off current	I <sub>EBO</sub>	V <sub>EB</sub> =9V, I <sub>C</sub> =0			100	μ A
DC current gain	h <sub>FE(1)</sub>	V <sub>CE</sub> =5V, I <sub>C</sub> =2A	10		40	
	h <sub>FE(2)</sub>	V <sub>CE</sub> =5V, I <sub>C</sub> =8A	5			
Collector-emitter saturation voltage	V <sub>CE(sat)1</sub>	I <sub>C</sub> =2A, I <sub>B</sub> =0.4A			1	V
	V <sub>CE(sat)2</sub>	I <sub>C</sub> =5A, I <sub>B</sub> =1A			2	V
	V <sub>CE(sat)3</sub>	I <sub>C</sub> =8A, I <sub>B</sub> =2A			3	V
Base-emitter saturation voltage	V <sub>BE(sat)1</sub>	I <sub>C</sub> =2A, I <sub>B</sub> =0.4A			1.2	V
	V <sub>BE(sat)2</sub>	I <sub>C</sub> =5A, I <sub>B</sub> =1A			1.6	V
Storage time	t <sub>S</sub>	I <sub>C</sub> =500mA (UI9600)	3		6	μ s
Fall time	t <sub>f</sub>	I <sub>C</sub> =500mA (UI9600)			0.5	μ s
Transition frequency	f <sub>T</sub>	V <sub>CE</sub> =10V, I <sub>C</sub> =0.5A, f=1MHz	4			MHz

#### CLASSIFICATION OF h<sub>FE(1)</sub>

Range	10-15	15-20	20-25	25-30	30-35	35-40

#### CLASSIFICATION OF t<sub>S</sub>

Rank	A	B	C
Range	3-4 (μ s)	4-5 (μ s)	5-6 (μ s)