

### Features

- InGaAs/InP PIN Photodiode
- High responsivity at 1310nm and 1550nm
- Low dark current
- Low intermodulation distortion
- High responsivity
- Hermetically sealed 3-pin metal case

### Packaging

- SM fiber pigtailed with optional FC/ST/SC connector

### Application

- Return path Analog CATV optical receivers to 2.5GHz
- RoHS Compliant available

### Absolute Maximum Ratings (Tc=25°C)

Parameter	Symbol	Value	Unit
Supply Reverse Voltage	V <sub>R</sub>	20	V
Forward Current	I <sub>F</sub>	2	mA
Reverse Current	I <sub>R</sub>	1	mA
Operating Temperature	T <sub>opr</sub>	-40 ~ 85	°C
Storage Temperature	T <sub>stg</sub>	-40 ~ 100	°C

### (All optical data refer to coupled 9/125 μm SM fiber)

### Optical and Electrical Characteristics (Tc=25°C)

Parameter	Symbol	Min.	Typ.	Max.	Unit	Notes
Operating Voltage	V <sub>op</sub>	-	-	15	V	-
Detection Range		1100	1310	1650	nm	-
Responsivity	R	0.75 0.8	0.8 0.9	- -	A/W	V <sub>R</sub> = 5V, λ = 1310nm V <sub>R</sub> = 5V, λ = 1550nm
Linearity IMD2	IMD2	-	-70	-	dBc	Note 1
Dark Current	I <sub>dark</sub>	-	-	0.8	nA	V <sub>R</sub> = 5V
Capacitance	C <sub>t</sub>	-	-	0.35	pF	Note 2
Rise / Fall Time	T <sub>r</sub> / T <sub>f</sub>	-	-	0.125	ns	V <sub>R</sub> = 5V, 10%~90%
Bandwidth	BW	8	-	-	GHz	V <sub>R</sub> = 5V
Optical Return Loss	ORL	40	-	-	dB	λ = 1310nm

#### Note:

1. V<sub>R</sub>=12V, P<sub>AVG</sub>=0dBm, MI=0.7, R<sub>LOAD</sub>=50Ω, f<sub>1</sub>+f<sub>2</sub>=324.25MHz, f<sub>1</sub>-f<sub>2</sub>=54.25MHz
2. V<sub>R</sub>=5V, Case grounded

## Pin Assignment

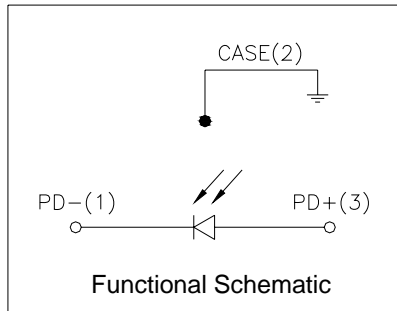

Pin Assignment
1~PD(-)
2~CASE
3~PD(+)

## Ordering Information

# R-11-040AX-P-SXX/XXX-X-XX

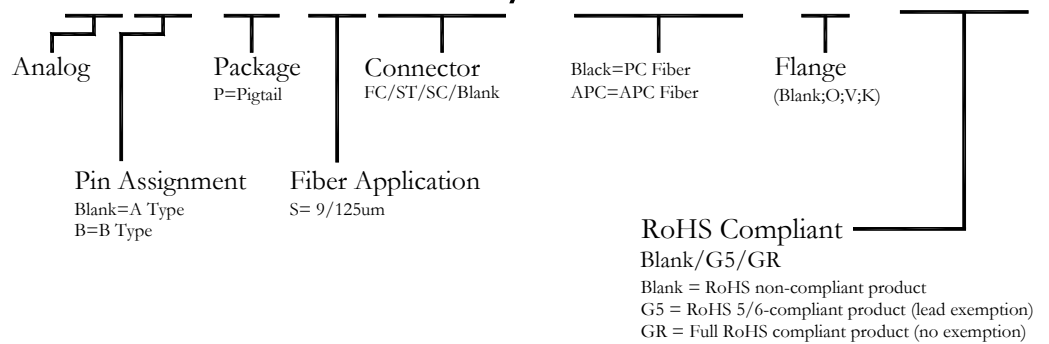

Mechanic Dimension (Units in mm)

Pin Assignment

A Type

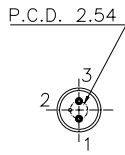

B Type

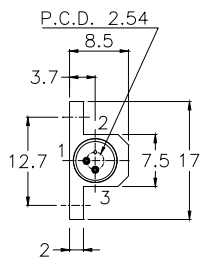
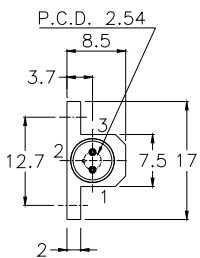
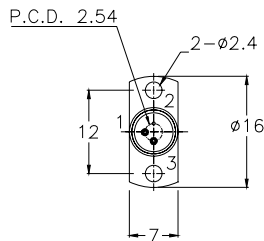
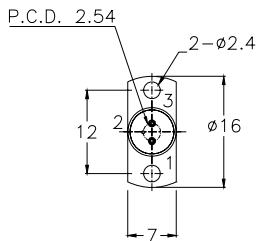
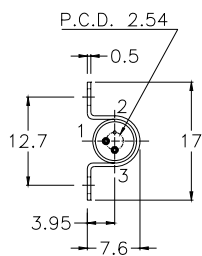
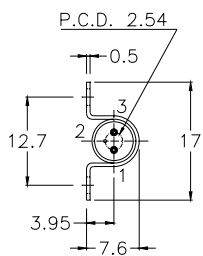
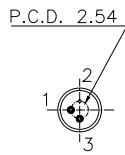

Flange Type

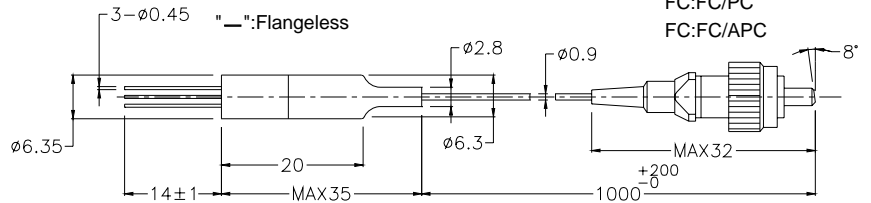

Connector Type

FC:FC/PC  
FC:FC/APC

"O":Horizontal (Omega Housing)

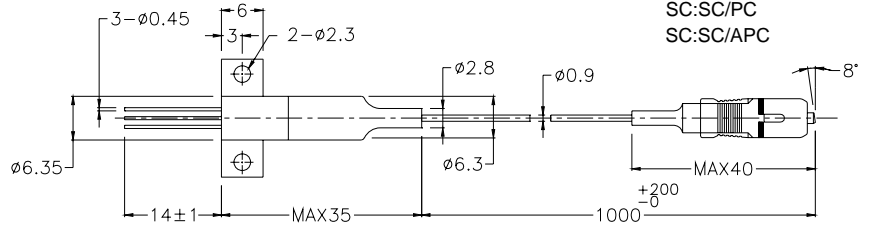

SC:SC/PC  
SC:SC/APC

"V":Vertical

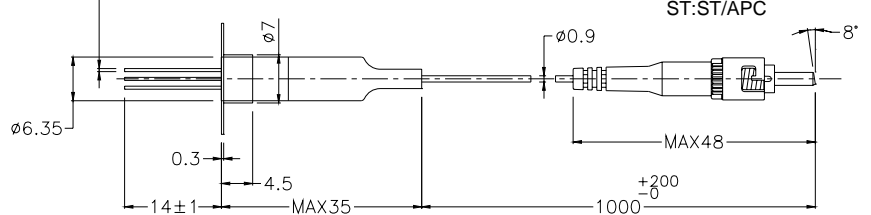

ST:ST/PC  
ST:ST/APC

"K":Horizontal (KX Housing)

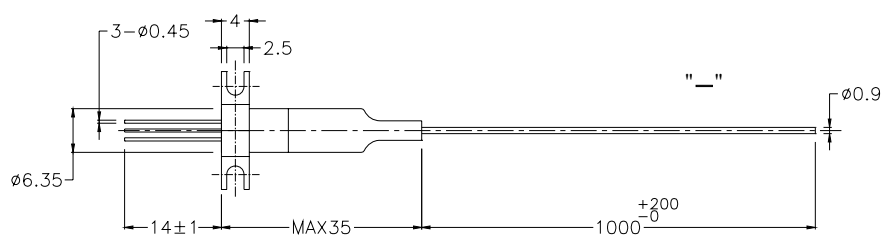

## Warnings

**Handling Precautions:** This device is susceptible to damage as a result of electrostatic discharge (ESD). A static free environment is highly recommended. Follow guidelines according to proper ESD procedures.

**Laser Safety:** Radiation emitted by laser devices can be dangerous to human eyes. Avoid eye exposure to direct or indirect radiation.

## Legal Notice

### **IMPORTANT NOTICE!**

All information contained in this document is subject to change without notice, at Source Photonics's sole and absolute discretion. Source Photonics warrants performance of its products to current specifications only in accordance with the company's standard one-year warranty; however, specifications designated as "preliminary" are given to describe components only, and Source Photonics expressly disclaims any and all warranties for said products, including express, implied, and statutory warranties, warranties of merchantability, fitness for a particular purpose, and non-infringement of proprietary rights. Please refer to the company's Terms and Conditions of Sale for further warranty information.

Source Photonics assumes no liability for applications assistance, customer product design, software performance, or infringement of patents, services, or intellectual property described herein. No license, either express or implied, is granted under any patent right, copyright, or intellectual property right, and Source Photonics makes no representations or warranties that the product(s) described herein are free from patent, copyright, or intellectual property rights. Products described in this document are NOT intended for use in implantation or other life support applications where malfunction may result in injury or death to persons. Source Photonics customers using or selling products for use in such applications do so at their own risk and agree to fully defend and indemnify Source Photonics for any damages resulting from such use or sale.

THE INFORMATION CONTAINED IN THIS DOCUMENT IS PROVIDED ON AN "AS IS" BASIS. Customer agrees that Source Photonics is not liable for any actual, consequential, exemplary, or other damages arising directly or indirectly from any use of the information contained in this document. Customer must contact Source Photonics to obtain the latest version of this publication to verify, before placing any order, that the information contained herein is current.

© Copyright Source Photonics, Inc. 2010

All rights reserved