

Military-Grade 10BASE-T interface module

- Fully integrated 10BASE-T module for adapter, hub, and motherboard applications.
- Designed to meet IEEE802.3i-1993 10BASE-T specifications.
- Low profile surface mount package
- 235°C peak infrared reflow temperature rating
- Operating temperature -40°C to +85°C.
- Parts can be screened to MIL-T-21038 and other military specific requirements

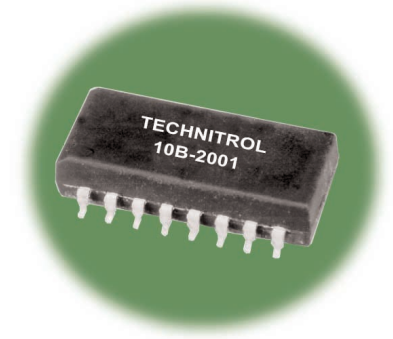

CHARACTERISTICS

Part Number	Insertion Loss 1-10 MHz (dB max) ¹	Attenuation XMIT (dB min) ¹			Return Loss 5 to 10 MHz (dB min)		Crosstalk (dB min)	Common Mode Rejection (dB min)				Pri-Sec Isolation (Vrms min)
		30 MHz	50 MHz	100 MHz	100 ohms	98 ±13 ohms		5-10 MHz	5-10 MHz	50 MHz	100 MHz	
10B-2001	-10	-30	-35	-35	-18	-15	-35	-60	-55	-50	-45	1500

1) Receive and transmit sides meet IEEE 802.3i-1993 specification, transmit side is enhanced for FCC/VE class B system emissions requirement. Specifications reflect filter sections, additional attenuation is due to pre-distortion resistors.

MECHANICAL OUTLINES

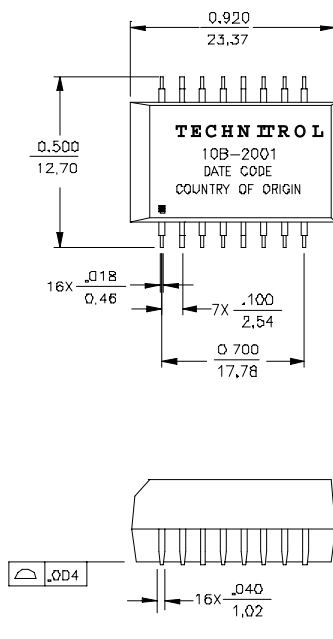

SUGGESTED SMD PAD LAYOUT

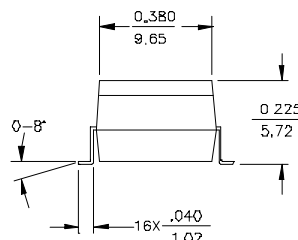
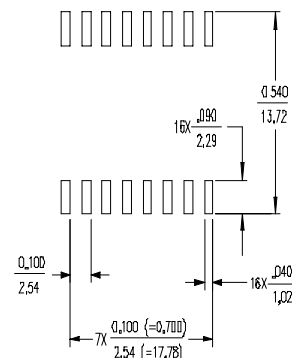

Notes:

1. Weight = 2.5 grams.
2. All dimensions are in ^{inches}/_{mm}.
3. Unless otherwise specified, all tolerances are ± ^{0.010}/_{0.254}.
4. All specifications and dimensions are subject to change without notice.



APPLICATION NOTES

The module contains low pass filters, isolation transformers, and common mode chokes. These components provide impedance matching, equipment isolation, and EMI compression to comply with IEEE requirements. User compliance with FCC/CSPR class B requirements can be achieved by applying rigorous design guidelines to suppress noise mechanisms. Attention to high frequency signal paths, proper PCB grounding techniques, and component placement is critical. Pins 5 and 12, when grounded, provide noise return paths. At

least one of these (typically pin 12) must be coupled with bypass capacitor. Recommended module orientation with respect to RJ45 connector is illustrated in the application circuit. Output pins 6 through 11 should be routed with short, matched traces to the connector for optimum EMI performance. The robust mechanical package withstands IR reflow temperatures up to 235°C. Compliant leads provide excellent solder-joint reliability with K.002 coplanarity. Modules are shipped in tubes.

SCHEMATIC

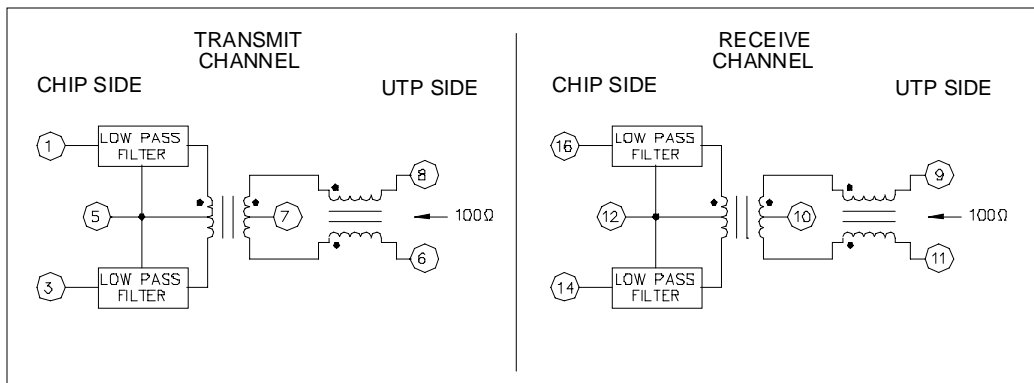

TYPICAL APPLICATION CIRCUIT

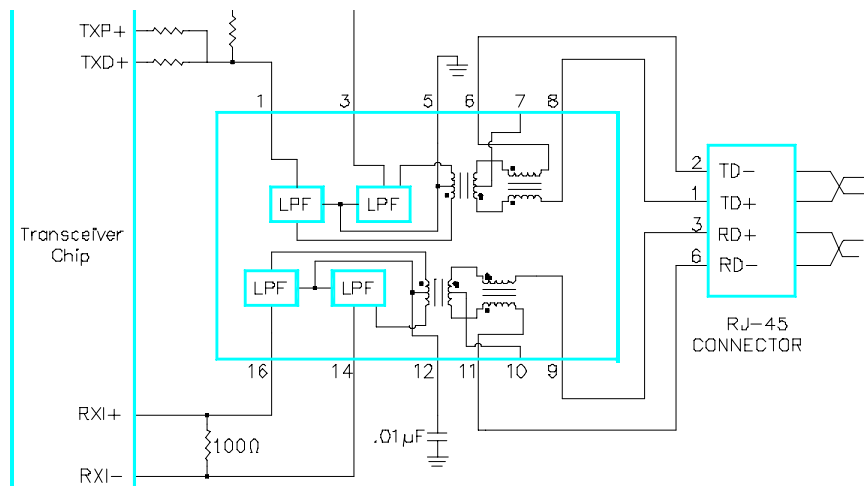

NOTE: Resistors **NOT** included in module