

# MAXIM

## +5V-Powered, Multi-Channel RS-232 Drivers/Receivers

### General Description

The MAX220-MAX249 family of line drivers/receivers is intended for all EIA/TIA-232E and V.28/V.24 communications interfaces, and in particular, for those applications where  $\pm 12V$  is not available.

These parts are particularly useful in battery-powered systems since their low-power shutdown mode reduces power dissipation to less than  $5\mu W$ . The MAX225, MAX233, MAX235, and MAX245-MAX247 use no external components and are recommended for applications where printed circuit board space is critical.

### Applications

Portable Computers  
 Low-Power Modems  
 Interface Translation  
 Battery-Powered RS-232 Systems  
 Multi-Drop RS-232 Networks

### Features

#### Superior to Bipolar

- ◆ Operate from Single +5V Power Supply (+5V and +12V—MAX231 and MAX239)
- ◆ Low-Power Receive Mode in Shutdown (MAX223/MAX242)
- ◆ Meet All EIA/TIA-232E and V.28 Specifications
- ◆ Multiple Drivers and Receivers
- ◆ 3-State Driver and Receiver Outputs
- ◆ Open-Line Detection (MAX243)

### Ordering Information

PART	TEMP. RANGE	PIN-PACKAGE
MAX220CPE	0°C to +70°C	16 Plastic DIP
MAX220CSE	0°C to +70°C	16 Narrow SO
MAX220CWE	0°C to +70°C	16 Wide SO
MAX220C/D	0°C to +70°C	Dice*
MAX220EPE	-40°C to +85°C	16 Plastic DIP
MAX220ESE	-40°C to +85°C	16 Narrow SO
MAX220EWE	-40°C to +85°C	16 Wide SO
MAX220EJE	-40°C to +85°C	16 CERDIP
MAX220MJE	-55°C to +125°C	16 CERDIP

Ordering Information continued at end of data sheet.  
 \*Contact factory for dice specifications.

### Selection Table

Part Number	Power Supply (V)	No. of RS-232 Drivers/Rx	No. of Ext. Caps	Nominal Cap. Value ( $\mu F$ )	SHDN & Three-State	Rx Active in SHDN	Data Rate (kbps)	Features
MAX220	+5	2/2	4	4.7/10	No		120	Ultra low-power, industry-standard pinout
MAX222	+5	2/2	4	0.1	Yes		200	+5V IBM PC serial port with receivers active in shutdown
MAX223 (MAX213)	+5	4/5	4	1.0 (0.1)	Yes	✓	120	MAX241 + receivers active in shutdown
MAX225	+5	5/5	0	—	Yes	✓	120	Available in SO
MAX230 (MAX200)	+5	5/0	4	1.0 (0.1)	Yes		120	5 drivers with shutdown
MAX231 (MAX201)	+5 and +7.5 to +13.2	2/2	2	1.0 (0.1)	No		120	Standard +5/+12V or battery supplies; same functions as MAX232
MAX232 (MAX202)	+5	2/2	4	1.0 (0.1)	No		120 (64)	Industry standard
MAX232A	+5	2/2	4	0.1	No		200	Higher slew rate, small caps
MAX233 (MAX203)	+5	2/2	0	—	No		120	No external caps
MAX233A	+5	2/2	0	—	No		200	No external caps, high slew rate
MAX234 (MAX204)	+5	4/0	4	1.0 (0.1)	No		120	Replaces 1488
MAX235 (MAX205)	+5	5/5	0	—	Yes		120	No external caps
MAX236 (MAX206)	+5	4/3	4	1.0 (0.1)	Yes		120	Shutdown, three-state
MAX237 (MAX207)	+5	5/3	4	1.0 (0.1)	No		120	Complements IBM PC serial port
MAX238 (MAX208)	+5	4/4	4	1.0 (0.1)	No		120	Replaces 1488 and 1489
MAX239 (MAX209)	+5 and +7.5 to +13.2	3/5	2	1.0 (0.1)	No		120	Standard +5/+12V or battery supplies; single package solution for IBM PC serial port
MAX240	+5	5/5	4	1.0	Yes		120	DIP or flatpack package
MAX241 (MAX211)	+5	4/5	4	1.0 (0.1)	Yes		120	Complete IBM PC serial port
MAX242	+5	2/2	4	0.1	Yes	✓	200	Separate shutdown and enable
MAX243	+5	2/2	4	0.1	No		200	Open-line detection simplifies cabling
MAX244	+5	8/10	4	1.0	No		120	High slew rate
MAX245	+5	8/10	0	—	Yes	✓	120	High slew rate, int. caps. two shutdown modes
MAX246	+5	8/10	0	—	Yes	✓	120	High slew rate, int. caps. three shutdown modes
MAX247	+5	8/9	0	—	Yes	✓	120	High slew rate, int. caps. nine operating modes
MAX248	+5	8/8	4	1.0	Yes	✓	120	High slew rate, selective half-chip enables
MAX249	+5	6/10	4	1.0	Yes	✓	120	Available in quad flatpack package

MAXIM

Maxim Integrated Products 2-85

Call toll free 1-800-998-8800 for free samples or literature.

MAX220-MAX249

2

# +5V-Powered, Multi-Channel RS-232 Drivers/Receivers

## ABSOLUTE MAXIMUM RATINGS—MAX220/222/232A/233A/242/243

Supply Voltage (V <sub>CC</sub> )	-0.3V to +6V	16-Pin Narrow SO (derate 8.70mW/°C above +70°C)	696mW
Input Voltages		16-Pin Wide SO (derate 9.52mW/°C above +70°C)	762mW
T <sub>IN</sub>	-0.3V to (V <sub>CC</sub> - 0.3V)	18-Pin Wide SO (derate 9.52mW/°C above +70°C)	762mW
R <sub>IN</sub>	±30V	20-Pin Wide SO (derate 10.00mW/°C above +70°C)	800mW
T <sub>OUT</sub> (Note 1)	±15V	16-Pin CERDIP (derate 10.00mW/°C above +70°C)	800mW
Output Voltages		18-Pin CERDIP (derate 10.53mW/°C above +70°C)	842mW
T <sub>OUT</sub>	±15V	Operating Temperature Ranges	
R <sub>OUT</sub>	-0.3V to (V <sub>CC</sub> + 0.3V)	MAX2 __ AC __, MAX2 __ C __	0°C to +70°C
Driver/Receiver Output Short Circuited to GND	Continuous	MAX2 __ AE __, MAX2 __ E __	-40°C to +85°C
Continuous Power Dissipation (T <sub>A</sub> = +70°C)		MAX2 __ AM __, MAX2 __ M __	-55°C to +125°C
16-Pin Plastic DIP (derate 10.53mW/°C above +70°C)	842mW	Storage Temperature Range	-65°C to +160°C
18-Pin Plastic DIP (derate 11.11mW/°C above +70°C)	889mW	Lead Temperature (soldering, 10 sec)	+300°
20-Pin Plastic DIP (derate 8.00mW/°C above +70°C)	440mW		

**Note 1:** Input voltage measured with T<sub>OUT</sub> in high-impedance state, SHDN or V<sub>CC</sub> = 0V.

Stresses beyond those listed under "Absolute Maximum Ratings" may cause permanent damage to the device. These are stress ratings only, and functional operation of the device at these or any other conditions beyond those indicated in the operational sections of the specifications is not implied. Exposure to absolute maximum rating conditions for extended periods may affect device reliability.

## ELECTRICAL CHARACTERISTICS—MAX220/222/232A/233A/242/243

(V<sub>CC</sub> = +5V ± 10%, C1-C4 = 0.1μF, T<sub>A</sub> = T<sub>MIN</sub> to T<sub>MAX</sub>, unless otherwise noted.)

PARAMETER	CONDITIONS		MIN	TYP	MAX	UNITS
<b>RS-232 TRANSMITTERS</b>						
Output Voltage Swing	All transmitter outputs loaded with 3kΩ to GND		±5	±8		V
Input Logic Threshold Low				1.4	0.8	V
Input Logic Threshold High			2	1.4		V
Logic Pull-Up/Input Current	Normal operation			5	40	μA
	SHDN = 0V, MAX222/242, shutdown			±0.01	±1	
Output Leakage Current	V <sub>CC</sub> = 5.5V, SHDN = 0V, V <sub>OUT</sub> = ±15V, MAX222/242			±0.01	±10	μA
	V <sub>CC</sub> = SHDN = 0V, V <sub>OUT</sub> = ±15V			±0.01	±10	
Data Rate	Except MAX220, normal operation			200	116	kbits/sec
	MAX220			22	20	
Transmitter Output Resistance	V <sub>CC</sub> = V+ V- = 0V, V <sub>OUT</sub> = ±2V		300	10M		Ω
Output Short-Circuit Current	V <sub>OUT</sub> = 0V		±7	±22		mA
<b>RS-232 RECEIVERS</b>						
RS-232 Input Voltage Operating Range					±30	V
RS-232 Input Threshold Low	V <sub>CC</sub> = 5V	Except MAX243 R <sub>2IN</sub>	0.8	1.3		V
		MAX243 R <sub>2IN</sub> (Note 2)	-3			
RS-232 Input Threshold High	V <sub>CC</sub> = 5V	Except MAX243 R <sub>2IN</sub>		1.8	2.4	V
		MAX243 R <sub>2IN</sub> (Note 2)		-0.5	-0.1	
RS-232 Input Hysteresis	Except MAX243, V <sub>CC</sub> = 5V, no hyst. in shdn.		0.2	0.5	1	V
	MAX243			1		
RS-232 Input Resistance			3	5	7	kΩ
TTL/CMOS Output Voltage Low	I <sub>OUT</sub> = 3.2mA			0.2	0.4	V
TTL/CMOS Output Voltage High	I <sub>OUT</sub> = -1.0mA		3.5	V <sub>CC</sub> - 0.2		V
TTL/CMOS Output Short-Circuit Current	Sourcing V <sub>OUT</sub> = GND		-2	-10		mA
	Shrinking V <sub>OUT</sub> = V <sub>CC</sub>		10	30		
TTL/CMOS Output Leakage Current	SHDN = V <sub>CC</sub> or EN = V <sub>CC</sub> , 0V ≤ V <sub>OUT</sub> ≤ V <sub>CC</sub>			±0.05	±10	μA

# +5V-Powered, Multi-Channel RS-232 Drivers/Receivers

**MAX220-MAX249**

## ELECTRICAL CHARACTERISTICS—MAX220/222/232A/233A/242/243 (continued)

( $V_{CC} = +5V \pm 10\%$ ,  $C_1-C_4 = 0.1\mu F$ ,  $T_A = T_{MIN}$  to  $T_{MAX}$ , unless otherwise noted.)

PARAMETER	CONDITIONS		MIN	TYP	MAX	UNITS	
EN Input Threshold Low	MAX242			1.4	0.8	V	
EN Input Threshold High	MAX242		2.0	1.4		V	
<b>POWER SUPPLY</b>							
Operating Supply Voltage			4.5		5.5	V	
V <sub>CC</sub> Supply Current (SHDN = V <sub>CC</sub> ), Figures 5, 6, 9, 19	No load	MAX220		0.5	2	mA	
		MAX222/232A/233A/242/243		4	10		
	3kΩ load both outputs	MAX220		12			
		MAX222/232A/233A/242/243		15			
Shutdown Supply Current	MAX222/242	T <sub>A</sub> = +25°C		0.1	10	μA	
		T <sub>A</sub> = 0° to +70°C		2	50		
		T <sub>A</sub> = -40° to +85°C		2	50		
		T <sub>A</sub> = -55° to +125°C		35	100		
SHDN Input Leakage Current	MAX222/242				±1	μA	
SHDN Threshold Low	MAX222/242			1.4	0.8	V	
SHDN Threshold High	MAX222/242		2.0	1.4		V	
<b>AC CHARACTERISTICS</b>							
Transition Slew Rate		C <sub>L</sub> = 50pF to 2500pF, R <sub>L</sub> = 3kΩ to 7kΩ, V <sub>CC</sub> = 5V, T <sub>A</sub> = +25°C, measured from +3V to -3V or -3V to +3V	MAX222/232A/233A/242/243	6	12	30	V/μs
		MAX220	1.5	3	30		
Transmitter Propagation Delay TLL to RS-232 (Normal Operation), Figure 1	t <sub>PHLT</sub>	MAX222/232A/233A/242/243		1.3	3.5	μs	
		MAX220		4	10		
	t <sub>PLHT</sub>	MAX222/232A/233A/242/243		1.5	3.5		
		MAX220		5	10		
Receiver Propagation Delay RS-232 to TLL (Normal Operation), Figure 2	t <sub>PHLR</sub>	MAX222/232A/233A/242/243		0.5	1	μs	
		MAX220		0.6	3		
	t <sub>PLHR</sub>	MAX222/232A/233A/242/243		0.6	1		
		MAX220		0.8	3		
Receiver Propagation Delay RS-232 to TLL (Shutdown), Figure 2	t <sub>PHLS</sub>	MAX242		0.5	10	μs	
	t <sub>PLHS</sub>	MAX242		2.5	10		
Receiver-Output Enable Time, Figure 3	t <sub>ER</sub>	MAX242		125	500	ns	
Receiver-Output Disable Time, Figure 3	t <sub>DR</sub>	MAX242		160	500	ns	
Transmitter-Output Enable Time (SHDN goes High), Figure 4	t <sub>ET</sub>	MAX222/242, 0.1μF caps (includes charge-pump start-up)		250		μs	
Transmitter-Output Disable Time (SHDN goes Low), Figure 4	t <sub>DT</sub>	MAX222/242, 0.1μF caps		600		ns	
Transmitter + to - Propagation Delay Difference (Normal Operation)	t <sub>PHLT</sub> - t <sub>PLHT</sub>	MAX222/232A/233A/242/243		300		ns	
		MAX220		2000			
Receiver + to - Propagation Delay Difference (Normal Operation)	t <sub>PHLR</sub> - t <sub>PLHR</sub>	MAX222/232A/233A/242/243		100		ns	
		MAX220		225			

2

**Note 2:** MAX243 R<sub>2OUT</sub> is guaranteed to be low when R<sub>2IN</sub> is ≥ 0V or is floating.

# +5V-Powered, Multi-Channel RS-232 Drivers/Receivers

## Typical Operating Characteristics

### MAX220/MAX222/MAX232A/MAX233A/MAX242/MAX243

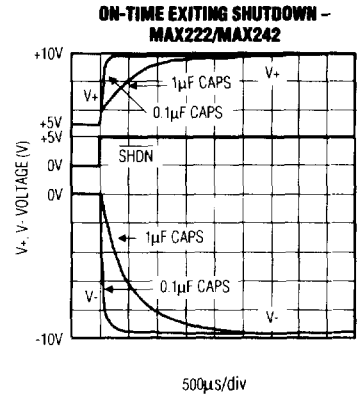
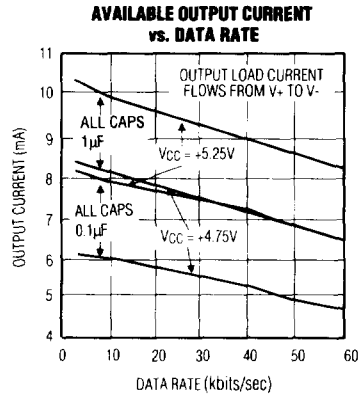
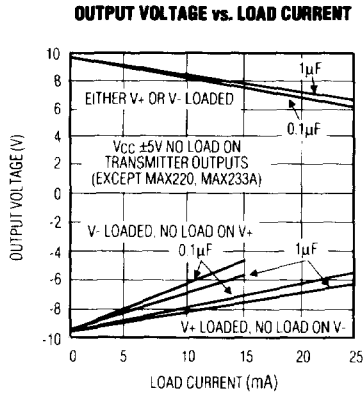

# +5V-Powered, Multi-Channel RS-232 Drivers/Receivers

**MAX220-MAX249**

## ABSOLUTE MAXIMUM RATINGS—MAX223/MAX230-MAX241

V <sub>CC</sub> .....	-0.3V to +6V	20-Pin Wide SO (derate 10.00mW/°C above +70°C) .....	800mW
V <sub>+</sub> .....	(V <sub>CC</sub> - 0.3V) to +14V	24-Pin Wide SO (derate 11.76mW/°C above +70°C) .....	941mW
V <sub>-</sub> .....	+0.3V to -14V	28-Pin Wide SO (derate 12.50mW/°C above +70°C) .....	1000mW
Input Voltages		44-Pin Plastic FP (derate 11.11mW/°C above +70°C) .....	889mW
T <sub>IN</sub> .....	-0.3V to (V <sub>CC</sub> + 0.3V)	14-Pin Cerdip (derate 9.09mW/°C above +70°C) .....	727mW
R <sub>IN</sub> .....	±30V	16-Pin Cerdip (derate 10.00mW/°C above +70°C) .....	800mW
Output Voltages		20-Pin Cerdip (derate 11.11mW/°C above +70°C) .....	889mW
T <sub>OUT</sub> .....	(V <sub>+</sub> + 0.3V) to (V <sub>-</sub> - 0.3V)	24-Pin Narrow Cerdip	
R <sub>OUT</sub> .....	-0.3V to (V <sub>CC</sub> + 0.3V)	(derate 12.50mW/°C above +70°C) .....	1000mW
Short-Circuit Duration, T <sub>OUT</sub> .....	Continuous	24-Pin Sidebrazed (derate 20.0mW/°C above +70°C) .....	1600mW
Continuous Power Dissipation (T <sub>A</sub> = +70°C)		28-Pin SSOP (derate 9.52mW/°C above +70°C) .....	762mW
14-Pin Plastic DIP (derate 10.00mW/°C above +70°C) .....		Operating Temperature Ranges	
16-Pin Plastic DIP (derate 10.53mW/°C above +70°C) .....		MAX2 __ C .....	0°C to +70°C
20-Pin Plastic DIP (derate 11.11mW/°C above +70°C) .....		MAX2 __ E .....	-40°C to +85°C
24-Pin Narrow Plastic DIP		MAX2 __ M .....	-55°C to +125°C
(derate 13.33mW/°C above +70°C) .....		Storage Temperature Range .....	-65°C to +160°C
1067mW		Lead Temperature (soldering, 10 sec) .....	+300°C
24-Pin Plastic DIP (derate 9.09mW/°C above +70°C) .....			
500mW			
16-Pin Wide SO (derate 9.52mW/°C above +70°C) .....			
762mW			

Stresses beyond those listed under "Absolute Maximum Ratings" may cause permanent damage to the device. These are stress ratings only, and functional operation of the device at these or any other conditions beyond those indicated in the operational sections of the specifications is not implied. Exposure to absolute maximum rating conditions for extended periods may affect device reliability.

## ELECTRICAL CHARACTERISTICS—MAX223/MAX230-MAX241

**2**

(MAX223/230/232/234/236/237/238/240/241 V<sub>CC</sub> = +5V ± 10%, MAX233/MAX235 V<sub>CC</sub> = 5V ± 5%, C1-C4 = 1.0μF, MAX231/MAX239 V<sub>CC</sub> = 5V ± 10%, V<sub>+</sub> = 7.5V to 13.2V, T<sub>A</sub> = T<sub>MIN</sub> to T<sub>MAX</sub>, unless otherwise noted.)

PARAMETER	CONDITIONS	MIN	TYP	MAX	UNITS
Output Voltage Swing	All transmitter outputs loaded with 30kΩ to ground	±5.0	±7.3		V
V <sub>CC</sub> Power-Supply Current	No load, T <sub>A</sub> = +25°C	MAX232/233	5	10	mA
		MAX232/230/234-238/240/241	7	15	
		MAX231/239	.4	1	
V <sub>+</sub> Power-Supply Current		MAX231	1.8	5	mA
		MAX239	5	15	
Shutdown Supply Current	T <sub>A</sub> = +25°C	MAX223	15	50	μA
		MAX241	1	10	
Input Logic Threshold Low	T <sub>IN</sub> ; EN, $\overline{\text{SHDN}}$ (MAX223), $\overline{\text{EN}}$ , SHDN (MAX230/235-241)			0.8	V
Input Logic Threshold High	T <sub>IN</sub>	2.0			
	EN, $\overline{\text{SHDN}}$ (MAX223), $\overline{\text{EN}}$ , SHDN (MAX230/235-241)	2.4			V
Logic Pull-Up Current	T <sub>IN</sub> = 0V		15	200	μA
Receiver Input Voltage Operating Range		-30		+30	V

# +5V-Powered, Multi-Channel RS-232 Drivers/Receivers

**MAX220-MAX249**

## ELECTRICAL CHARACTERISTICS — MAX223/MAX230-MAX241 (continued)

(MAX223/230/232/234/236/237/238/240/241  $V_{CC} = +5V \pm 10\%$ , MAX233/MAX235  $V_{CC} = 5V \pm 5\%$ , C1-C4 = 1.0 $\mu$ F, MAX231/MAX239  $V_{CC} = 5V \pm 10\%$ ,  $V_+ = 7.5V$  to 13.2V,  $T_A = T_{MIN}$  to  $T_{MAX}$ , unless otherwise noted.)

PARAMETER	CONDITIONS		MIN	TYP	MAX	UNITS
RS-232 Input Threshold Low	$T_A = +25^\circ\text{C}$ $V_{CC} = 5V$	Normal operation SHDN = 5V (MAX223) SHDN = 0V (MAX235-MAX241)	0.8	1.2		V
		Shutdown (MAX223) SHDN = 0V, EN = 5V (R4, R5)	0.6	1.5		
RS-232 Input Threshold High	$T_A = +25^\circ\text{C}$ $V_{CC} = 5V$	Normal operation SHDN = 5V (MAX223) SHDN = 0V (MAX235-MAX241)		1.7	2.4	V
		Shutdown (MAX223) SHDN = 0V, EN = 5V (R4, R5)		1.5	2.4	
RS-232 Input Hysteresis	$V_{CC} = 5V$ ; no hysteresis in shutdown		0.2	0.5	1.0	V
RS-232 Input Resistance	$T_A = +25^\circ\text{C}$ , $V_{CC} = 5V$		3	5	7	k $\Omega$
TTL/CMOS Output Voltage Low	$I_{OUT} = 1.6\text{mA}$ (MAX231-233 $I_{OUT} = 3.2\text{mA}$ )				0.4	V
TTL/CMOS Output Voltage High	$I_{OUT} = 1.0\text{mA}$		3.5	$V_{CC} - 0.4$		V
TTL/CMOS Output Leakage Current	$0V \leq R_{OUT} \leq V_{CC}$ ; EN = 0V (MAX223); $\overline{EN} = V_{CC}$ (MAX235-241)			0.05	$\pm 10$	$\mu\text{A}$
Receiver Output Enable Time	Normal operation	MAX223		600		ns
		MAX235-MAX241		400		
Receiver Output Disable Time	Normal operation	MAX223		900		ns
		MAX235-MAX241		250		
Propagation Delay	RS-232 IN to TTL/CMOS OUT, $C_L = 150\text{pF}$	Normal operation		0.5	10	$\mu\text{s}$
		SHDN = 0V (MAX223)	$t_{PHLS}$	4	40	
			$t_{PLHS}$	6	40	
Transition Region Slew Rate	MAX223/MAX230/MAX234-241 $T_A = +25^\circ\text{C}$ , $V_{CC} = 5V$ $R_L = 3\text{k}\Omega$ to 7k $\Omega$ , $C_L = 50\text{pF}$ to 2500pF, measured from +3V to -3V or -3V to +3V		3	5.1	30	V/ $\mu\text{s}$
	MAX231/MAX232/MAX233 $T_A = +25^\circ\text{C}$ , $V_{CC} = 5V$ $R_L = 3\text{k}\Omega$ to 7k $\Omega$ , $C_L = 50\text{pF}$ to 2500pF, measured from +3V to -3V or -3V to +3V			4	30	
Transmitter Output Resistance	$V_{CC} = V_+ = V_- = 0V$ , $V_{OUT} = \pm 2V$		300			$\Omega$
Receiver Out Short-Circuit Current			$\pm 10$			mA

# +5V-Powered, Multi-Channel RS-232 Drivers/Receivers

## Typical Operating Characteristics

MAX220-MAX249

### MAX223/MAX230/MAX234-241

**TRANSMITTER OUTPUT VOLTAGE (V<sub>OH</sub>) vs. V<sub>CC</sub>**

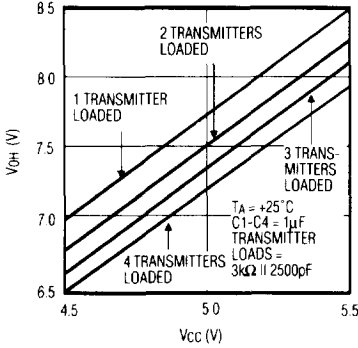

**TRANSMITTER OUTPUT VOLTAGE (V<sub>OH</sub>) vs. LOAD CAPACITANCE AT DIFFERENT DATA RATES**

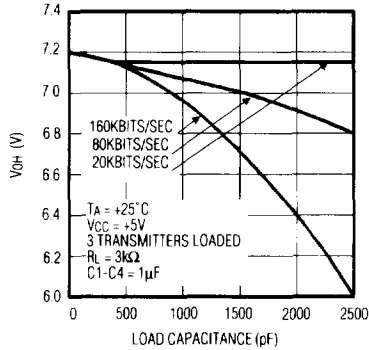

**TRANSMITTER SLEW RATE vs. LOAD CAPACITANCE**

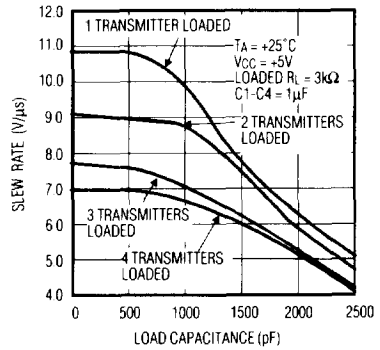

**TRANSMITTER OUTPUT VOLTAGE (V<sub>OL</sub>) vs. V<sub>CC</sub>**

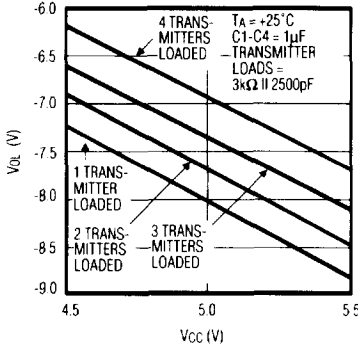

**TRANSMITTER OUTPUT VOLTAGE (V<sub>OL</sub>) vs. LOAD CAPACITANCE AT DIFFERENT DATA RATES**

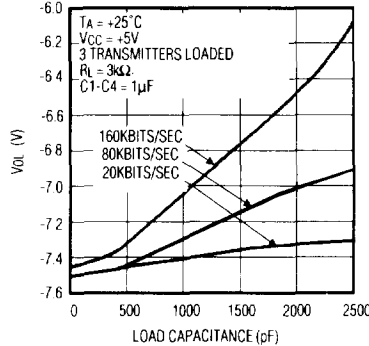

**TRANSMITTER OUTPUT VOLTAGE V<sub>+</sub>, V<sub>-</sub> vs. LOAD CURRENT**

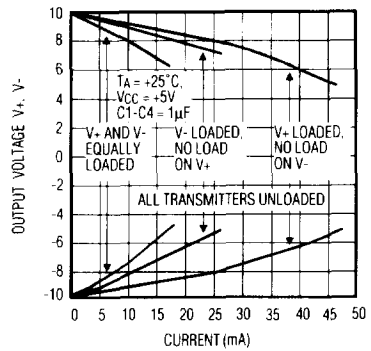

**V<sub>+</sub>, V<sub>-</sub> WHEN EXITING SHUTDOWN (1µF CAPACITORS)**

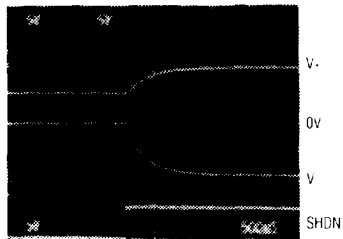

\*SHUTDOWN POLARITY IS REVERSED FOR THE MAX241

2

# +5V-Powered, Multi-Channel RS-232 Drivers/Receivers

**MAX220-MAX249**

## ABSOLUTE MAXIMUM RATINGS—MAX225/MAX244-MAX249

Supply Voltage (V <sub>CC</sub> )	-0.3V to +6V	Continuous Power Dissipation (T <sub>A</sub> = +70°C)
Input Voltages		28-Pin Wide SO (derate 12.50mW/°C above +70°C) ..1000mW
T <sub>IN</sub> : ENA, ENB, ENR, ENT, ENRA, ENRB, ENTA, ENTB	-0.3V to (V <sub>CC</sub> + 0.3V)	40-Pin Plastic DIP (derate 11.11mW/°C above +70°C) .611mW
R <sub>IN</sub>	±25V	44-Pin PLCC (derate 13.33mW/°C above +70°C) .....1067mW
T <sub>OUT</sub> (Note 3)	±15V	Operating Temperature Ranges:
R <sub>OUT</sub>	-0.3V to (V <sub>CC</sub> + 0.3V)	MAX225C __, MAX24_C __ .....0°C to +70°C
Short Circuit (1 output at a time)		MAX225E __, MAX24_E __ .....-40°C to +85°C
T <sub>OUT</sub> to GND	Continuous	Storage Temperature Range .....-65°C to +160°C
R <sub>OUT</sub> to GND	Continuous	Lead Temperature (soldering, 10 sec) .....+300°C

**Note 3:** Input Voltage measured with transmitter output in a high-impedance state, shutdown, or V<sub>CC</sub> = 0V.

Stresses beyond those listed under "Absolute Maximum Ratings" may cause permanent damage to the device. These are stress ratings only, and functional operation of the device at these or any other conditions beyond those indicated in the operational sections of the specifications is not implied. Exposure to absolute maximum rating conditions for extended periods may affect device reliability.

## ELECTRICAL CHARACTERISTICS—MAX225/MAX244-MAX249

(MAX225 V<sub>CC</sub> = 5.0V ± 5%; MAX244-MAX249 V<sub>CC</sub> = +5.0V ± 10%, external capacitors C1-C4 = 1μF, T<sub>A</sub> = T<sub>MIN</sub> to T<sub>MAX</sub>, unless otherwise noted.)

PARAMETER	CONDITIONS		MIN	TYP	MAX	UNITS
<b>RS-232 TRANSMITTERS</b>						
Input Logic Threshold Low				1.4	0.8	V
Input Logic Threshold High			2	1.4		V
Logic Pull-Up/Input Current	Tables1A-1D	Normal operation		10	50	μA
		Shutdown		±0.01	±1	
Data Rate	Tables1A-1D, Normal operation			120	64	kbits/sec
Output Voltage Swing	All transmitter outputs loaded with 30kΩ to GND		±5	±7.5		V
Output Leakage Current (Shutdown)	Tables1A-1D	ENA, ENB, ENT, ENTA, ENTB = V <sub>CC</sub>		±0.01	±25	μA
				±0.01	±25	
Transmitter Output Resistance	V <sub>CC</sub> = V <sub>+</sub> = V <sub>-</sub> = 0V, V <sub>OUT</sub> = ±2V (Note 4)		300	10M		Ω
Output Short-Circuit Current	V <sub>OUT</sub> = 0V		±7	±30		mA
<b>RS-232 RECEIVERS</b>						
RS-232 Input Voltage Operating Range					±25	V
RS-232 Input Threshold Low	V <sub>CC</sub> = 5V		0.8	1.3		V
RS-232 Input Threshold High	V <sub>CC</sub> = 5V			1.8	2.4	V
RS-232 Input Hysteresis	V <sub>CC</sub> = 5V		0.2	0.5	1.0	V
RS-232 Input Resistance			3	5	7	kΩ
TTL/CMOS Output Voltage Low	I <sub>OUT</sub> = 3.2mA			0.2	0.4	V
TTL/CMOS Output Voltage High	I <sub>OUT</sub> = -1.0mA		3.5	V <sub>CC</sub> - 0.2		V
TTL/CMOS Output Short-Circuit Current	Sourcing V <sub>OUT</sub> = GND		-2	-10		mA
	Sinking V <sub>OUT</sub> = V <sub>CC</sub>		10	30		
TTL/CMOS Output Leakage Current	Normal operation, outputs disabled, Tables 1A-1D, 0V ≤ V <sub>OUT</sub> ≤ V <sub>CC</sub> , ENR <sub>L</sub> = V <sub>CC</sub>			±0.05	±0.10	μA



# +5V-Powered, Multi-Channel RS-232 Drivers/Receivers

**MAX220-MAX249**

## ELECTRICAL CHARACTERISTICS—MAX225/MAX244-MAX249 (continued)

(MAX225  $V_{CC} = 5.0V \pm 5\%$ ; MAX244-MAX249  $V_{CC} = +5.0V \pm 10\%$ , external capacitors C1-C4 =  $1\mu F$ ,  $T_A = T_{MIN}$  to  $T_{MAX}$ , unless otherwise noted.)

PARAMETER	CONDITIONS		MIN	TYP	MAX	UNITS
<b>POWER SUPPLY AND CONTROL LOGIC</b>						
Operating Supply Voltage	MAX225		4.75		5.25	V
	MAX244-MAX249		4.5		5.5	
$V_{CC}$ Supply Current (Normal Operation)	No Load	MAX225		10	20	mA
		MAX244-MAX249		11	30	
	3k $\Omega$ loads on all outputs	MAX225		40		
		MAX244-MAX249		57		
Shutdown Supply Current	$T_A = +25^\circ C$			8	25	$\mu A$
	$T_A = T_{MIN}$ to $T_{MAX}$				50	
Control Input	Leakage Current				$\pm 1$	$\mu A$
	Threshold Low			1.4	0.8	V
	Threshold High		2.4	1.4		
<b>AC CHARACTERISTICS</b>						
Transition Slew Rate	$C_L = 50pF$ to $2500pF$ , $R_L = 3k\Omega$ to $7k\Omega$ , $V_{CC} = 5V$ , $T_A = +25^\circ C$ , measured from $+3V$ to $-3V$ or $-3V$ to $+3V$		5	10	30	V/ $\mu s$
Transmitter Propagation Delay TTL to RS-232 (Normal Operation), Figure 1	tPHLT			1.3	3.5	$\mu s$
	tPLHT			1.5	3.5	
Receiver Propagation Delay TTL to RS-232 (Normal Operation), Figure 2	tPHLR			0.6	1.5	$\mu s$
	tPLHR			0.6	1.5	
Receiver Propagation Delay TTL to RS-232 (Low Power Mode), Figure 2	tPHLS			0.6	10	$\mu s$
	tPLHS			3.0	10	
Transmitter + to - Propagation Delay Difference (Normal Operation)	tPHLT - tPLHT			350		ns
Receiver + to - Propagation Delay Difference (Normal Operation)	tPHLT - tPLHT			350		ns
Receiver-Output Enable Time, Figure 3	tER			100	500	ns
Receiver-Output Disable Time, Figure 3	tDR			100	500	ns
Transmitter Enable Time	tET	MAX246-249 (excludes charge-pump startup)		5		$\mu s$
		MAX225/MAX245-MAX249 (includes charge-pump startup)		10		ms
Transmitter Disable Time, Figure 4	tDT			100		ns

**2**

**Note 4:** The 300 $\Omega$  minimum specification complies with EIA/TIA-232E, but the actual resistance when in shutdown mode or  $V_{CC} = 0$  is 10M $\Omega$  as is implied by the leakage specification.

# +5V-Powered, Multi-Channel RS-232 Drivers/Receivers

MAX220-MAX249

## Typical Operating Characteristics

### MAX225/MAX244-MAX249

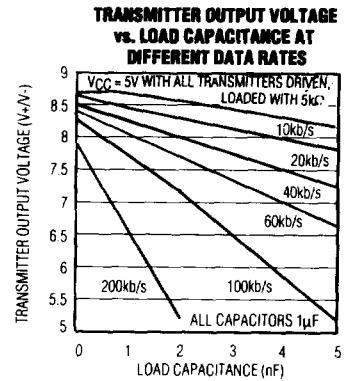
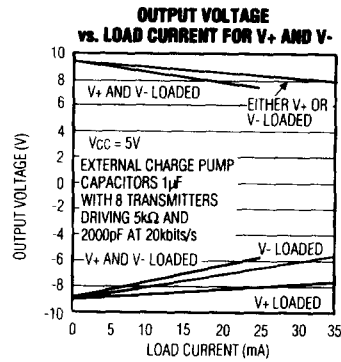
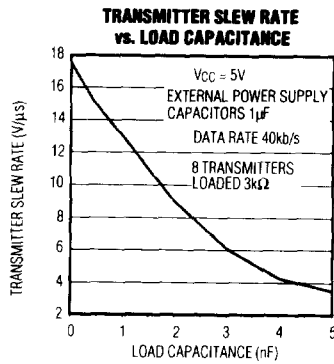

# +5V-Powered, Multi-Channel RS-232 Drivers/Receivers

**MAX220-MAX249**

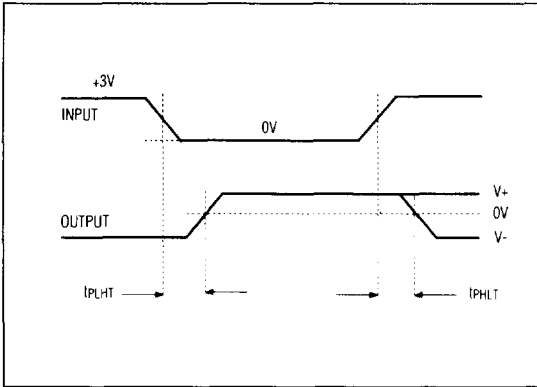

Figure 1. Transmitter Propagation Delay Timing

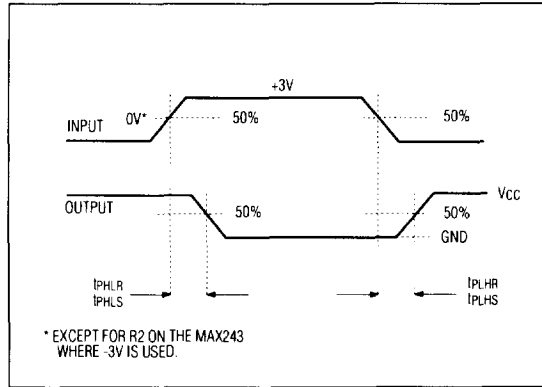

Figure 2. Receiver Propagation Delay Timing

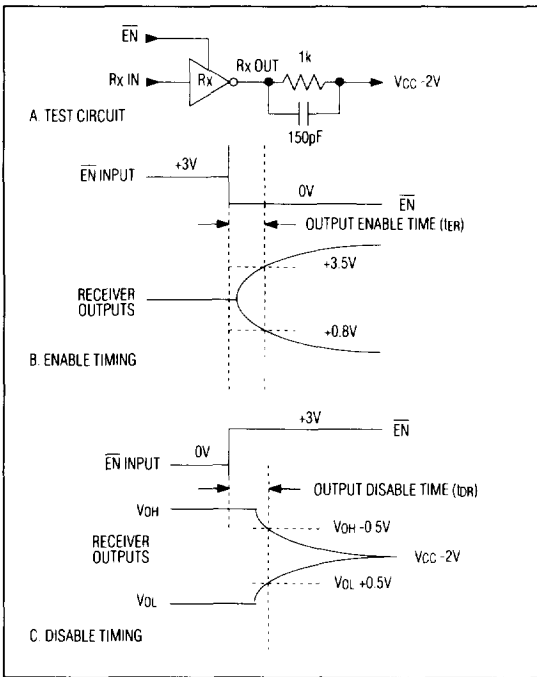

Figure 3. Receiver-Output Enable and Disable Timing

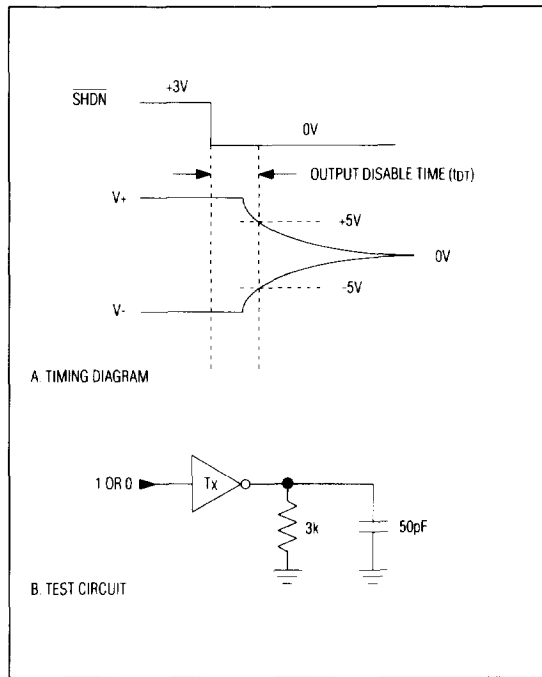

Figure 4. Transmitter-Output Disable Timing

**2**

# **+5V-Powered, Multi-Channel RS-232 Drivers/Receivers**

**Table 1a. MAX225 Control Pin Configurations**

ENT	ENR	OPERATION STATUS	TRANSMITTERS	RECEIVERS
0	0	Normal Operation	All Active	All Active
0	1	Normal Operation	All Active	All 3-State
1	0	Shutdown	All 3-State	All Low-Power Receive Mode
1	1	Shutdown	All 3-State	All 3-State

**Table 1b. MAX245 Control Pin Configurations**

ENT	ENR	OPERATION STATUS	TRANSMITTERS		RECEIVERS	
			TA1-TA4	TB1-TB4	RA1-RA5	RB1-RB5
0	0	Normal Operation	All Active	All Active	All Active	All Active
0	1	Normal Operation	All Active	All Active	RA1-RA4 3-State RA5 Active	RB1-RB4 3-State RB5 Active
1	0	Shutdown	All 3-State	All 3-State	All Low Power Receiver Mode	All Low Power Receiver Mode
1	1	Shutdown	All 3-State	All 3-State	RA1-RA4 3-State RA5 Low-Power Receiver Mode	RB1-RB4 3-State RA5 Low-Power Receiver Mode

**Table 1c. MAX246 Control Pin Configurations**

ENA	ENB	OPERATION STATUS	TRANSMITTERS		RECEIVERS	
			TA1-TA4	TB1-TB4	RA1-RA5	RB1-RB5
0	0	Normal Operation	All Active	All Active	All Active	All Active
0	1	Normal Operation	All Active	All 3-State	All Active	RB1-RB4 3-State RB5 Active
1	0	Shutdown	All 3-State	All Active	RA1-RA4 3-State RA5 Active	All Active
1	1	Shutdown	All 3-State	All 3-State	RA1-RA4 3-State RA5 Low-Power Receiver Mode	RB1-RB4 3-State RA5 Low-Power Receiver Mode

# +5V-Powered, Multi-Channel RS-232 Drivers/Receivers

**MAX220-MAX249**

**2**

**Table 1d. MAX247/248/249 Control Pin Configurations**

ENT <sub>A</sub>	ENT <sub>B</sub>	ENR <sub>A</sub>	ENR <sub>B</sub>	OPERATION STATUS	TRANSMITTERS			RECEIVERS	
					MAX247	TA1-TA4	TB1-TB4	RA1-RA4	RB1-RB5
					MAX248	TA1-TA4	TB1-TB4	RA1-RA4	RB1-RB4
					MAX249	TA1-TA3	TB1-TB3	RA1-RA5	RB1-RB5
0	0	0	0	Normal Operation		All Active	All Active	All Active	All Active
0	0	0	1	Normal Operation		All Active	All Active	All Active	All 3-State, except RB5 stays active on MAX247
0	0	1	0	Normal Operation		All Active	All Active	All 3-State	All Active
0	0	1	1	Normal Operation		All Active	All Active	All 3-State	All 3-State, except RB5 stays active on MAX247
0	1	0	0	Normal Operation		All Active	All 3-State	All Active	All Active
0	1	0	1	Normal Operation		All Active	All 3-State	All Active	All 3-State, except RB5 stays active on MAX247
0	1	1	0	Normal Operation		All Active	All 3-State	All 3-State	All Active
0	1	1	1	Normal Operation		All Active	All 3-State	All 3-State	All 3-State, except RB5 stays active on MAX247
1	0	0	0	Normal Operation		All 3-State	All Active	All Active	All Active
1	0	0	1	Normal Operation		All 3-State	All Active	All Active	All 3-State, except RB5 stays active on MAX247
1	0	1	0	Normal Operation		All 3-State	All Active	All 3-State	All Active
1	0	1	1	Normal Operation		All 3-State	All Active	All 3-State	All 3-State, except RB5 stays active on MAX247
1	1	0	0	Shutdown		All 3-State	All 3-State	Low-Power Receive Mode	Low-Power Receive Mode
1	1	0	1	Shutdown		All 3-State	All 3-State	Low-Power Receive Mode	All 3-State, except RB5 stays active on MAX247
1	1	1	0	Shutdown		All 3-State	All 3-State	All 3-State	Low-Power Receive Mode
1	1	1	1	Shutdown		All 3-State	All 3-State	All 3-State	All 3-State, except RB5 stays active on MAX247

## +5V-Powered, Multi-Channel RS-232 Drivers/Receivers

### Detailed Description

The MAX220-MAX249 contain four sections: dual charge-pump DC-DC voltage converters, RS-232 drivers, RS-232 receivers, and receiver and transmitter enable control inputs.

#### Dual Charge-Pump Voltage Converter

The MAX220-MAX249 have two internal charge-pumps that convert +5V to  $\pm 10V$  (unloaded) for RS-232 driver operation. The first converter uses capacitor C1 to double the +5V input to +10V on C3 at the V+ output. The second converter uses capacitor C2 to invert +10V to -10V on C4 at the V- output.

A small amount of power may be drawn from the +10V (V+) and -10V (V-) outputs to power external circuitry (see *Typical Operating Characteristics*), except on the MAX225 and MAX245-MAX247, where these pins are not available. V+ and V- are not regulated, so the output voltage drops with increasing load current. Do not load V+ and V- to a point that violates the minimum  $\pm 5V$  EIA/TIA-232E driver output voltage when sourcing current from V+ and V- to external circuitry.

When using the shutdown feature in the MAX222, MAX225, MAX230, MAX235, MAX236, MAX240, MAX241 and MAX245-MAX249 avoid using V+ and V- to power external circuitry. When these parts are shut down, V- falls to 0V, and V+ falls to +5V. For applications where a +10V external supply is applied to the V+ pin (instead of using the internal charge pump to generate +10V), the C1 capacitor must not be installed and the SHDN pin must be tied to  $V_{CC}$ . This is because V+ is internally connected to  $V_{CC}$  in shutdown mode.

#### RS-232 Drivers

The typical driver output voltage swing is  $\pm 8V$  when loaded with a nominal  $5k\Omega$  RS-232 receiver and  $V_{CC} = +5V$ . Output swing is guaranteed to meet the EIA/TIA-232E and V.28 specification, that calls for  $\pm 5V$  minimum driver output levels under worst-case conditions. These include a minimum  $3k\Omega$  load,  $V_{CC} = +4.5V$ , and maximum operating temperature. Unloaded driver output voltage ranges from (V+ -1.3V) to (V- +0.5V).

Input thresholds are both TTL and CMOS compatible. The inputs of unused drivers can be left unconnected since  $400k\Omega$  input pull-up resistors to  $V_{CC}$  are built-in. The pull-up resistors force the outputs of unused drivers low because all drivers invert. The internal input pull-up resistors typically source  $12\mu A$ , except in shutdown mode where the pull-ups are disabled. Driver outputs turn off and enter a high-impedance state—where leakage current is typically microamperes (maximum  $25\mu A$ )—when in shutdown mode, in three-state mode, or when device power is removed. Outputs can be driven to  $\pm 15V$ . The power-supply current typically drops to  $8\mu A$  in shutdown mode.

The MAX239 has a receiver 3-state control line, and the MAX223, MAX225, MAX235, MAX236, MAX240 and MAX241 have both a receiver 3-state control line and a low-power shutdown control. The receiver TTL/CMOS outputs are in a high-impedance 3-state mode whenever the 3-state ENable line is high, and are also high-impedance whenever the shutdown control line is high.

When in low-power shutdown mode, the driver outputs are turned off and their leakage current is less than  $1\mu A$  with the driver output pulled to ground. The driver output leakage remains less than  $1\mu A$ , even if the transmitter output is backdriven between 0V and ( $V_{CC} + 6V$ ). Below -0.5V the transmitter is diode clamped to ground with  $1k\Omega$  series impedance. The transmitter is also zener clamped to approximately  $V_{CC} + 6V$ , with a series impedance of  $1k\Omega$ .

The driver output slew rate is limited to less than  $30V/\mu s$  as required by the EIA/TIA-232E and V.28 specifications. Typical slew rates are  $24V/\mu s$  unloaded and  $10V/\mu s$  loaded with  $3\Omega$  and  $2500pF$ .

#### RS-232 Receivers

EIA/TIA-232E and V.28 specifications define a voltage level greater than 3V as a logic 0, so all receivers invert. Input thresholds are set at 0.8V and 2.4V, so receivers respond to TTL level inputs as well as EIA/TIA-232E and V.28 levels.

The receiver inputs withstand an input overvoltage up to  $\pm 25V$  and provide input terminating resistors with nominal  $5k\Omega$  values. The receivers implement Type 1 interpretation of the fault conditions of V.28 and EIA/TIA-232E.

The receiver input hysteresis is typically 0.5V with a guaranteed minimum of 0.2V. This produces clear output transitions with slow-moving input signals, even with moderate amounts of noise and ringing. The receiver propagation delay is typically 600ns and is independent of input swing direction.

#### Low-Power Receive Mode

The low-power receive-mode feature of the MAX223, MAX242, and MAX245-MAX249 puts the IC into shutdown mode, but still allows it to receive information. This is important for applications where systems are periodically awakened to look for activity. Using low-power receive mode, the system can still receive a signal that will activate it on command and prepare it for communication at faster data rates. This operation conserves system power.

#### MAX243—Negative Threshold

The MAX243 is pin compatible with the MAX232A, differing only in that RS-232 cable fault protection is removed on one of the two receiver inputs. This means that control lines such as CTS and RTS can either be driven or left floating without interrupting communication. Different cables are not needed to interface with different pieces of equipment.

# +5V-Powered, Multi-Channel RS-232 Drivers/Receivers

The input threshold of the receiver without cable fault protection is  $-0.8V$  rather than  $+1.4V$ . Its output goes positive only if the input is connected to a control line that is actively driven negative. If not driven, it defaults to the 0 or "OK to send" state. Normally, the MAX243's other receiver ( $+1.4V$  threshold) is used for the data line (TD or RD), while the negative threshold receiver is connected to the control line (DTR, DTS, CTS, RTS, etc.).

Other members of the RS-232 family implement the optional cable fault protection as specified by EIA/TIA-232E specifications. This means a receiver output goes high whenever its input is driven negative, left floating, or shorted to ground. The high output tells the serial communications IC to stop sending data. To avoid this, the control lines must either be driven or connected with jumpers to an appropriate positive voltage level.

## Shutdown—MAX222-MAX242

On the MAX222, MAX235, MAX236, MAX240, and MAX241, all receivers are disabled during shutdown. On the MAX223 and MAX242, two receivers continue to operate in a reduced power mode when the chip is in shutdown. Under these conditions, the propagation delay increases to about  $2.5\mu s$  for a high-to-low input transition. When in shutdown, the receiver acts as a CMOS inverter with no hysteresis. The MAX223 and MAX242 also have a receiver output enable input ( $\overline{EN}$ ) that allows receiver output control independent of  $\overline{SHDN}$ . With all other devices,  $\overline{SHDN}$  also disables the receiver outputs.

The MAX225 provides five transmitters and five receivers, while the MAX245 provides ten receivers and eight transmitters. Both devices have separate receiver and transmitter-enable controls. The charge pumps turn off and the devices shutdown when a logic high is applied to the  $\overline{ENT}$  input. In this state, the supply current drops to less than  $25\mu A$  and the receivers continue to operate in a low-power receive mode. Driver outputs enter a high-impedance state (three-state mode). On the MAX225, all five receivers are controlled by the  $\overline{ENR}$  input. On the MAX245, eight of the receiver outputs are controlled by the  $\overline{ENR}$  input, while the remaining two receivers (RA5 and RB5) are always active. RA1-RA4 and RB1-RB4 are put in a three-state mode when  $\overline{ENR}$  is a logic high.

## Receiver and Transmitter Enable Control Inputs

The MAX225 and MAX245-MAX249 feature transmitter and receiver enable controls.

The receivers have three modes of operation: full-speed receive (normal active), three-state (disabled), and low-power receive (enabled receivers continue to function at lower data rates). The receiver enable inputs control the

full-speed receive and three-state modes. The transmitters have two modes of operation: full-speed transmit (normal active) and three-state (disabled). The transmitter enable inputs also control the shutdown mode. The device enters shutdown mode when all transmitters are disabled. Enabled receivers function in the low-power receive mode when in shutdown.

Tables 1A-1D define the control states. The MAX244 has no control pins and is not included in these tables.

The MAX246 has ten receivers and eight drivers with two control pins, each controlling one side of the device. A logic high at the A-side control input ( $\overline{ENA}$ ) causes the four A-side receivers and drivers to go into a three-state mode. Similarly, the B-side control input ( $\overline{ENB}$ ) causes the four B-side drivers and receivers to go into a three-state mode. As in the MAX245, one A-side and one B-side receiver (RA5 and RB5) remain active at all times. The entire device is put into shutdown mode when both the A and B sides are disabled, ( $\overline{ENA} = \overline{ENB} = +5V$ ).

The MAX247 provides nine receivers and eight drivers with four control pins. The  $\overline{ENRA}$  and  $\overline{ENRB}$  receiver enable inputs each control four receiver outputs. The  $\overline{ENTA}$  and  $\overline{ENTB}$  transmitter enable inputs each control four drivers. The ninth receiver (RB5) is always active. The device enters shutdown mode with a logic high on both  $\overline{ENTA}$  and  $\overline{ENTB}$ .

The MAX248 provides eight receivers and eight drivers with four control pins. The  $\overline{ENRA}$  and  $\overline{ENRB}$  receiver enable inputs each control four receiver outputs. The  $\overline{ENTA}$  and  $\overline{ENTB}$  transmitter enable inputs control four drivers each. This part does not have an always-active receiver. The device enters shutdown mode and transmitters go into a three-state mode with a logic high on both  $\overline{ENTA}$  and  $\overline{ENTB}$ .

The MAX249 provides ten receivers and six drivers with four control pins. The  $\overline{ENRA}$  and  $\overline{ENRB}$  receiver enable inputs each control five receiver outputs. The  $\overline{ENTA}$  and  $\overline{ENTB}$  transmitter enable inputs control three drivers each. There is no always-active receiver. The device enters shutdown mode and transmitters go into a three-state mode with a logic high on both  $\overline{ENTA}$  and  $\overline{ENTB}$ . In shutdown mode, active receivers operate in a low-power receive mode at data rates up to 20kbits/s.

## Applications Information

Figures 5 through 25 show pin configurations and typical operating circuits. In applications that are sensitive to power-supply noise,  $V_{CC}$  should be decoupled to ground with a capacitor of the same value as C1 and C2 connected as close as possible to the device.

# +5V-Powered, Multi-Channel RS-232 Drivers/Receivers

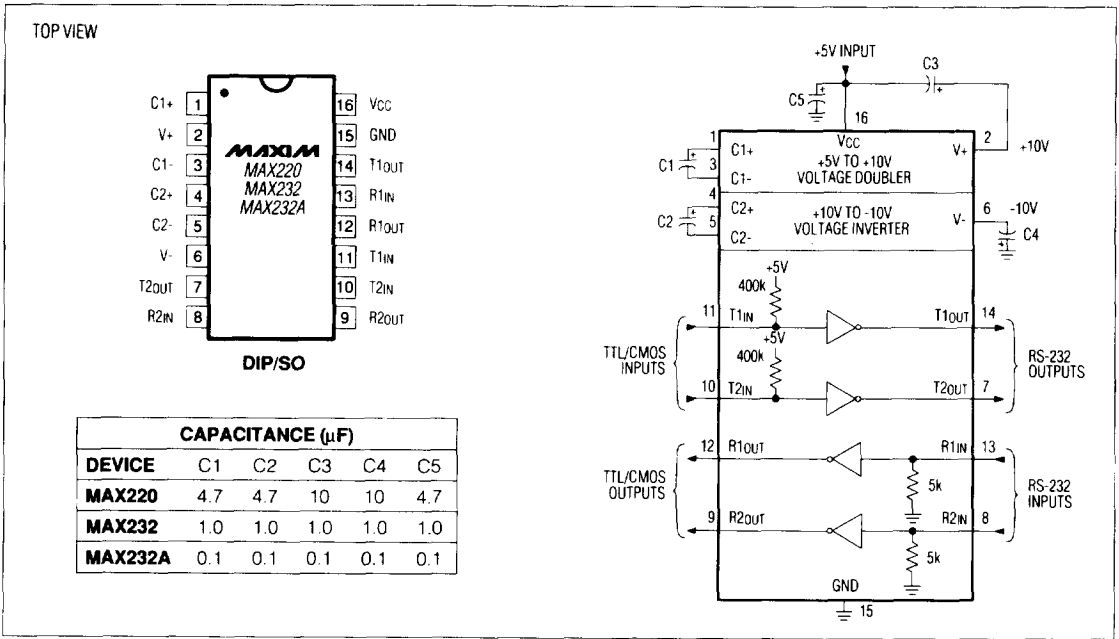

Figure 5. MAX220/232/232A Pin Configuration and Typical Operating Circuit

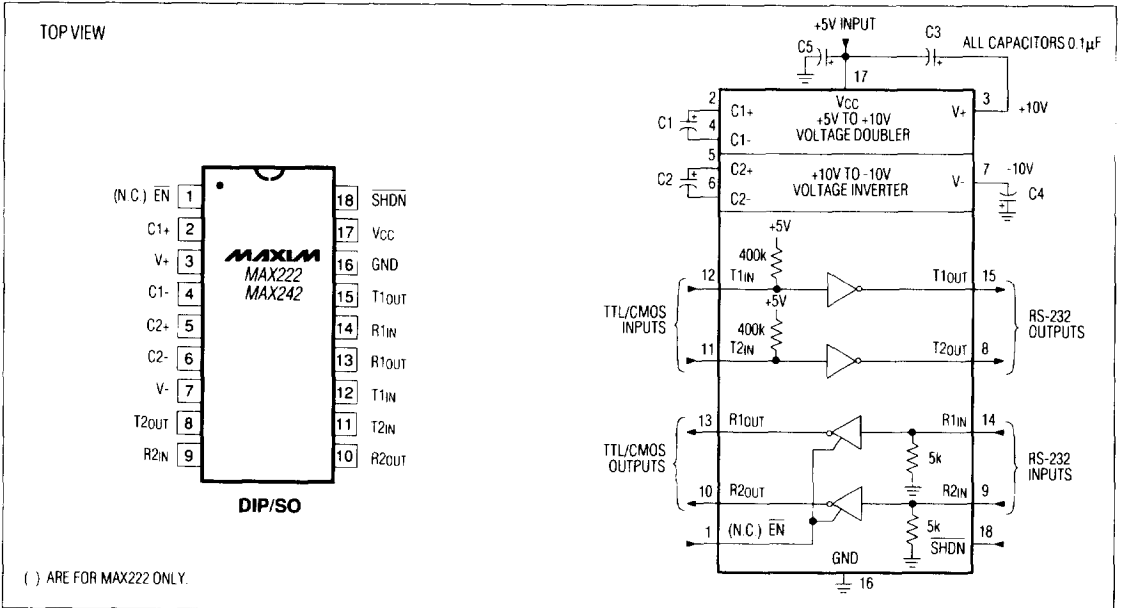

Figure 6. MAX222/MAX242 Pin Configuration and Typical Operating Circuit



# +5V-Powered, Multi-Channel RS-232 Drivers/Receivers

**MAX220-MAX249**

**2**

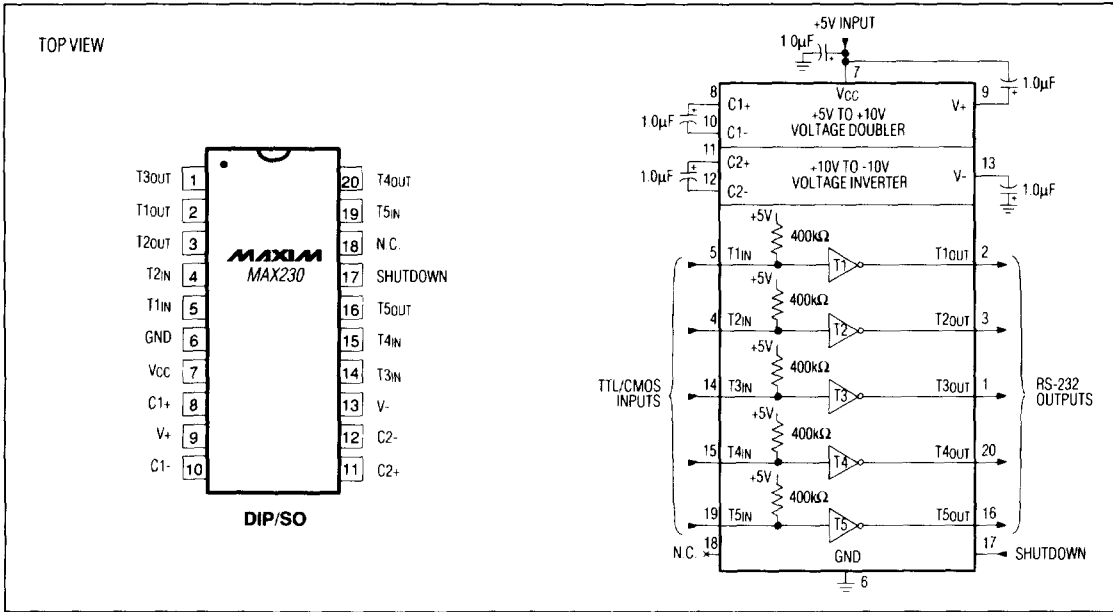

Figure 7. MAX230 Pin Configuration and Typical Operating Circuit

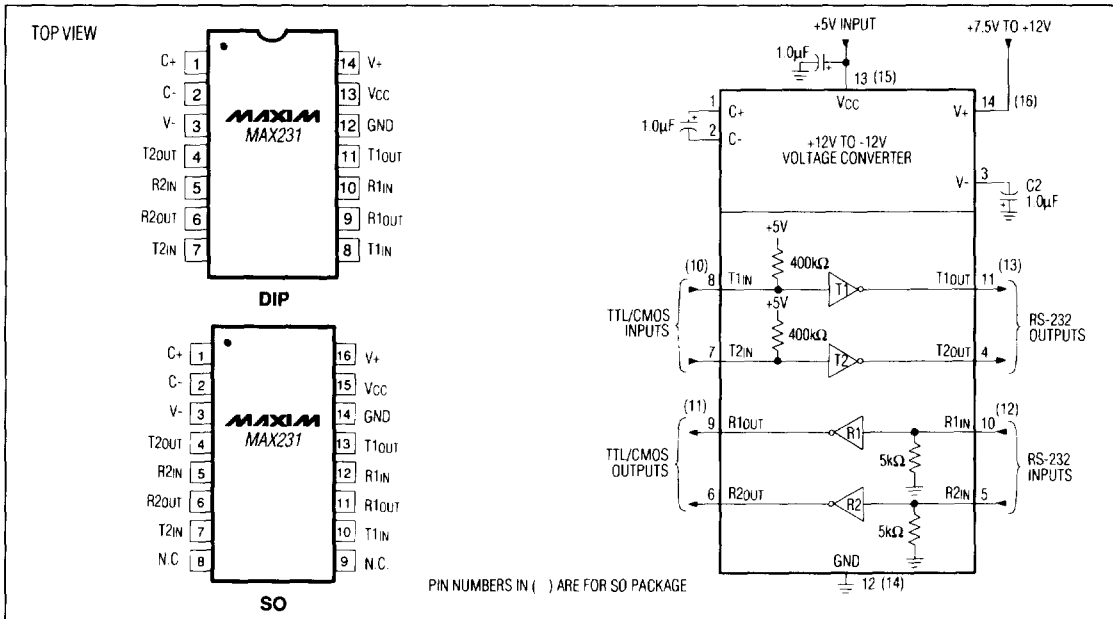

Figure 8. MAX230 Pin Configurations and Typical Operating Circuit

# +5V-Powered, Multi-Channel RS-232 Drivers/Receivers

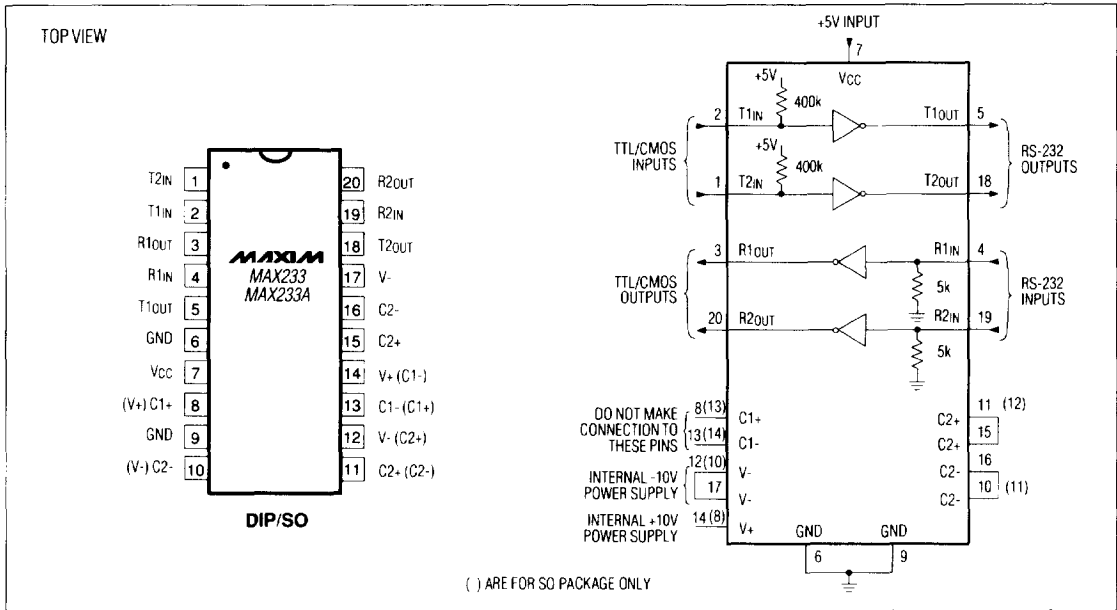

Figure 9. MAX233/MAX233A Pin Configuration and Typical Operating Circuit

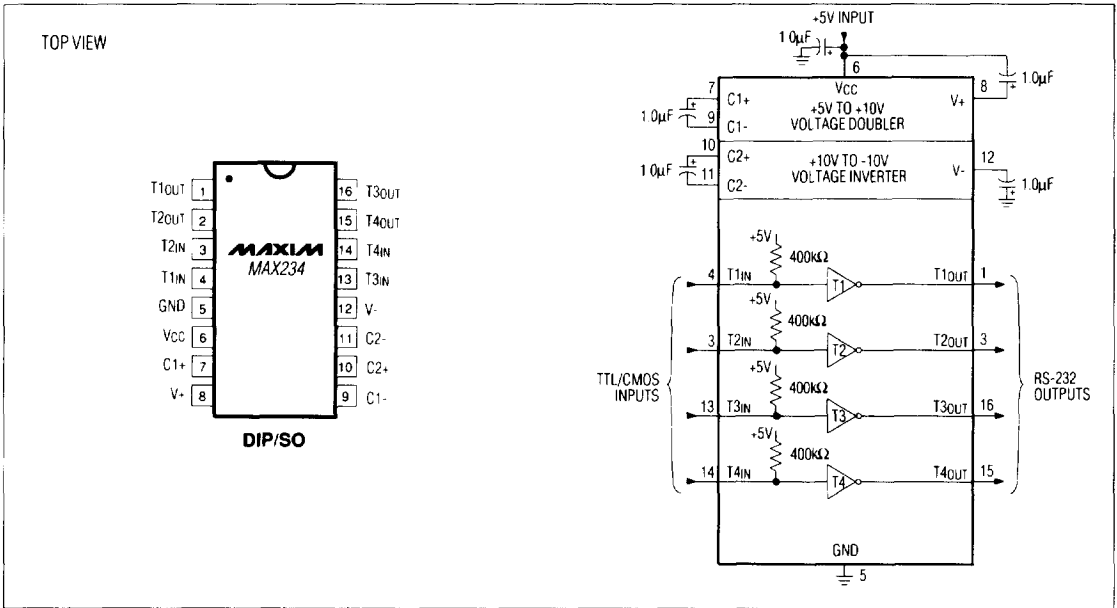

Figure 10. MAX234 Pin Configuration and Typical Operating Circuit

# +5V-Powered, Multi-Channel RS-232 Drivers/Receivers

**MAX220-MAX249**

**2**

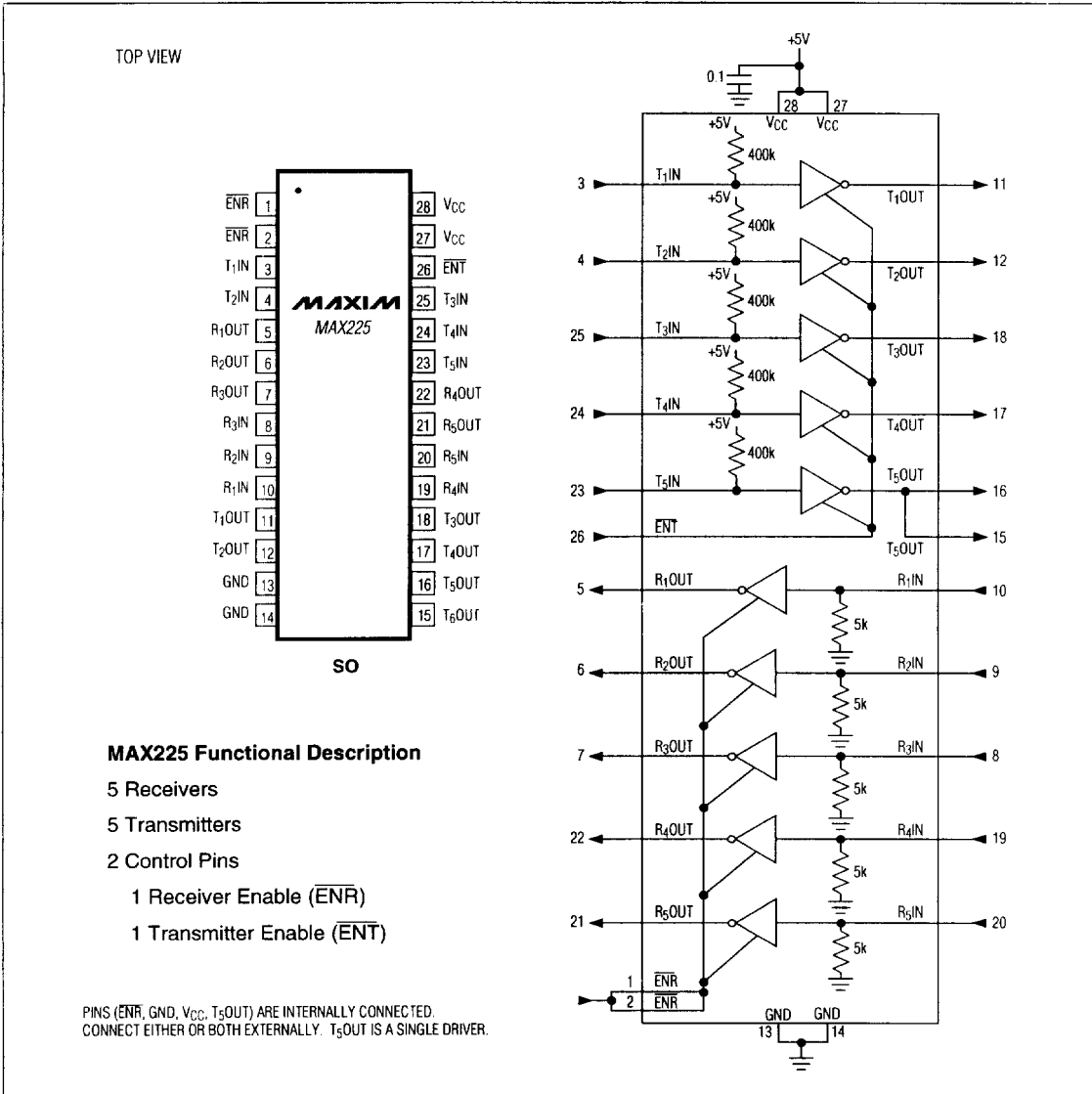

Figure 11. MAX225 Pin Configuration and Typical Operating Circuit

# +5V-Powered, Multi-Channel RS-232 Drivers/Receivers

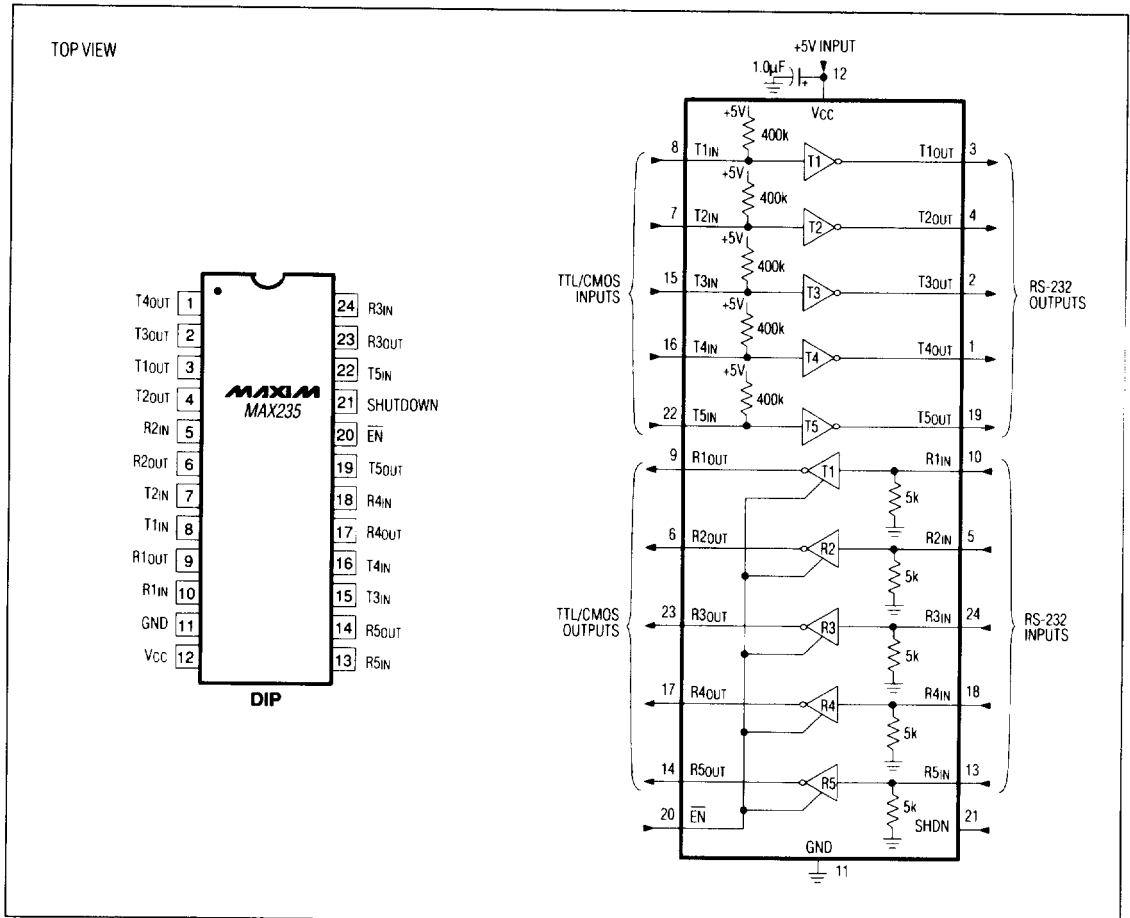

Figure 12. MAX235 Pin Configuration and Typical Operating Circuit

# +5V-Powered, Multi-Channel RS-232 Drivers/Receivers

**MAX220-MAX249**

2

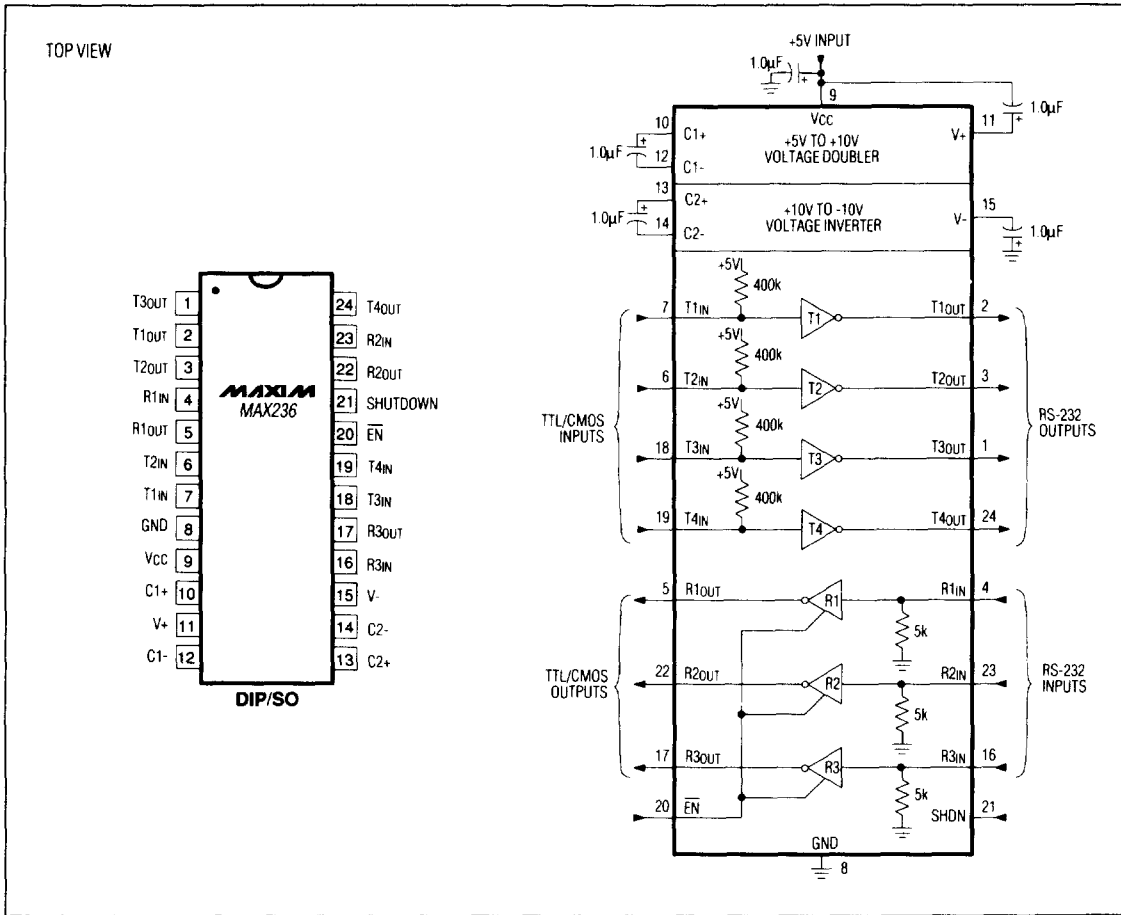
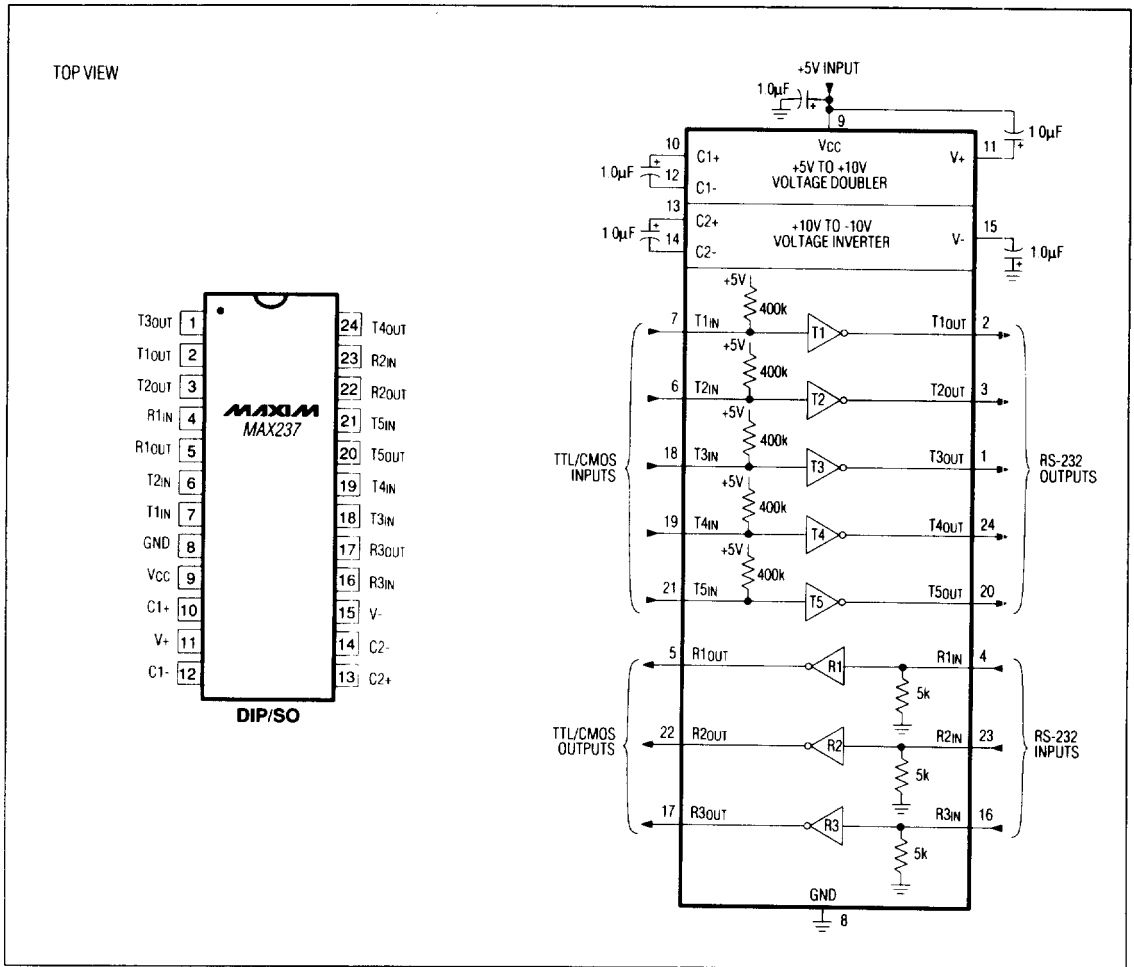

Figure 13. MAX236 Pin Configuration and Typical Operating Circuit

# +5V-Powered, Multi-Channel RS-232 Drivers/Receivers



# +5V-Powered, Multi-Channel RS-232 Drivers/Receivers

**MAX220-MAX249**

2

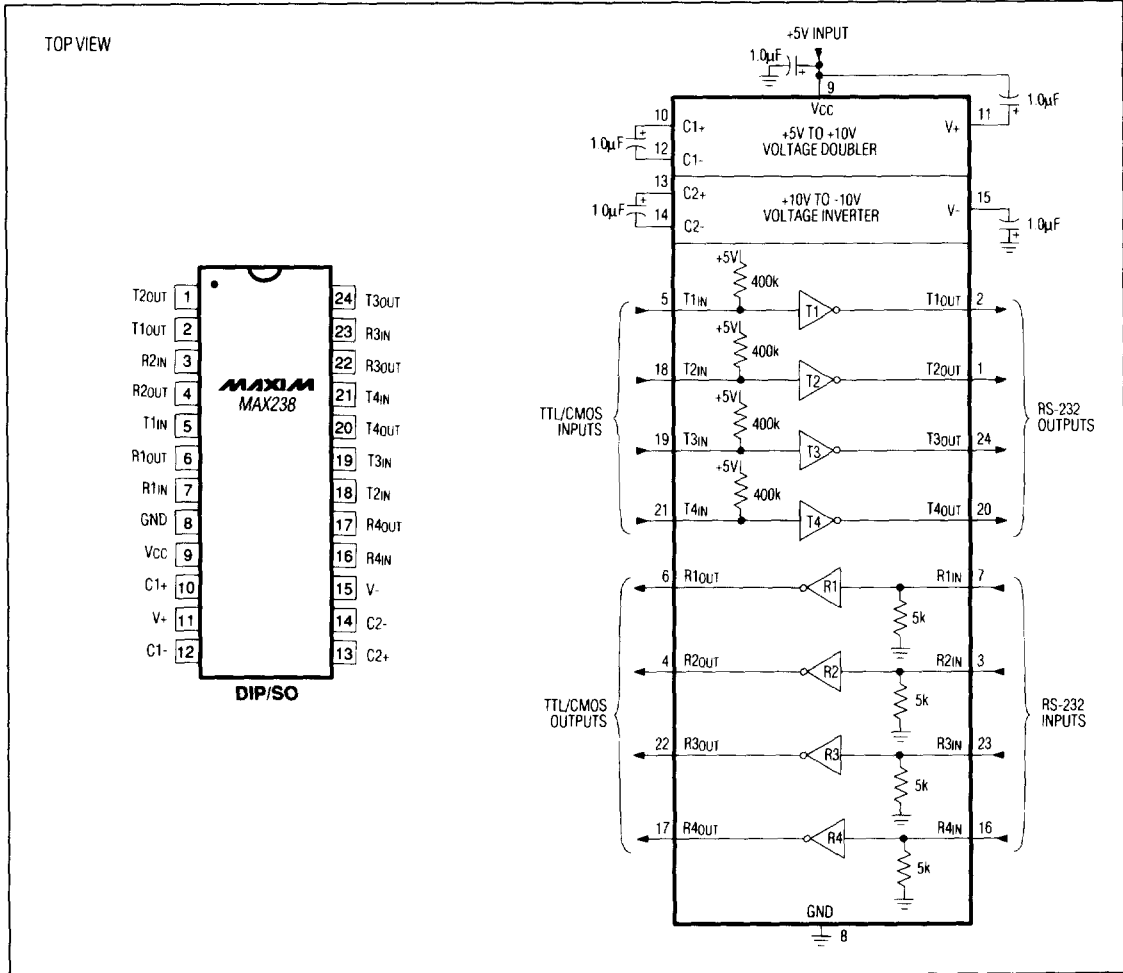

Figure 15. MAX238 Pin Configuration and Typical Operating Circuit

# +5V-Powered, Multi-Channel RS-232 Drivers/Receivers

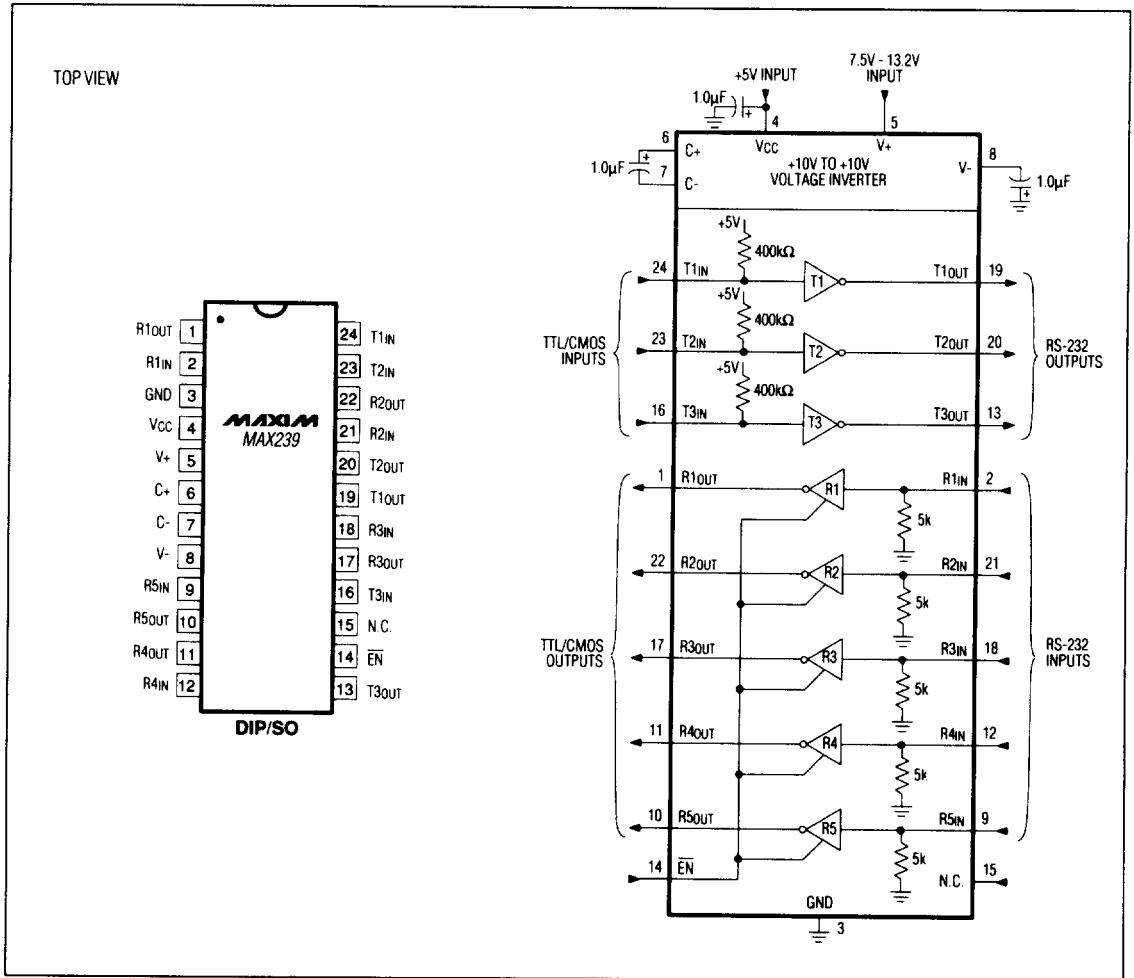

Figure 16. MAX239 Pin Configuration and Typical Operating Circuit



# +5V-Powered, Multi-Channel RS-232 Drivers/Receivers

**MAX220-MAX249**

2

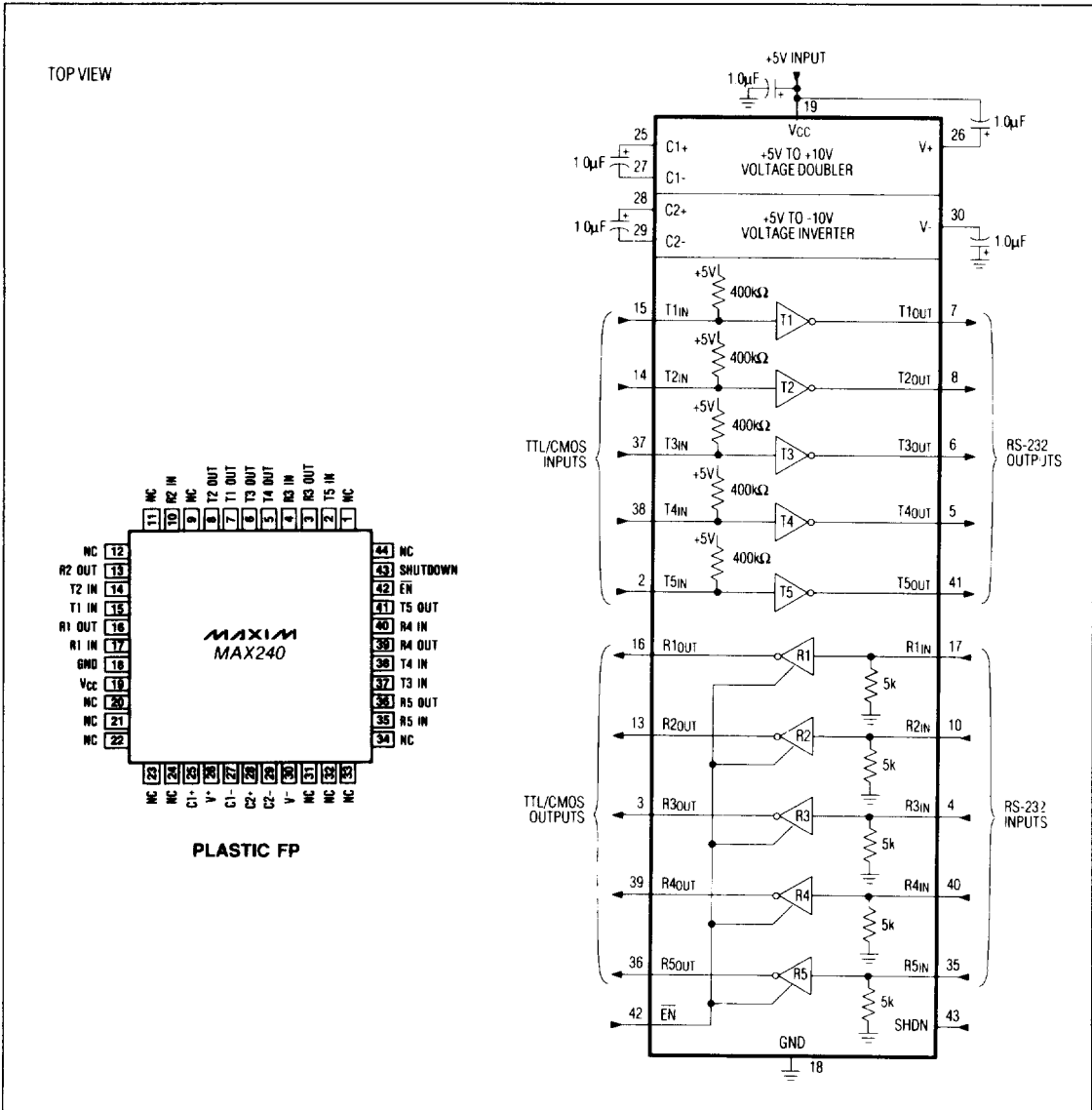

Figure 17. MAX240 Pin Configuration and Typical Operating Circuit

# +5V-Powered, Multi-Channel RS-232 Drivers/Receivers

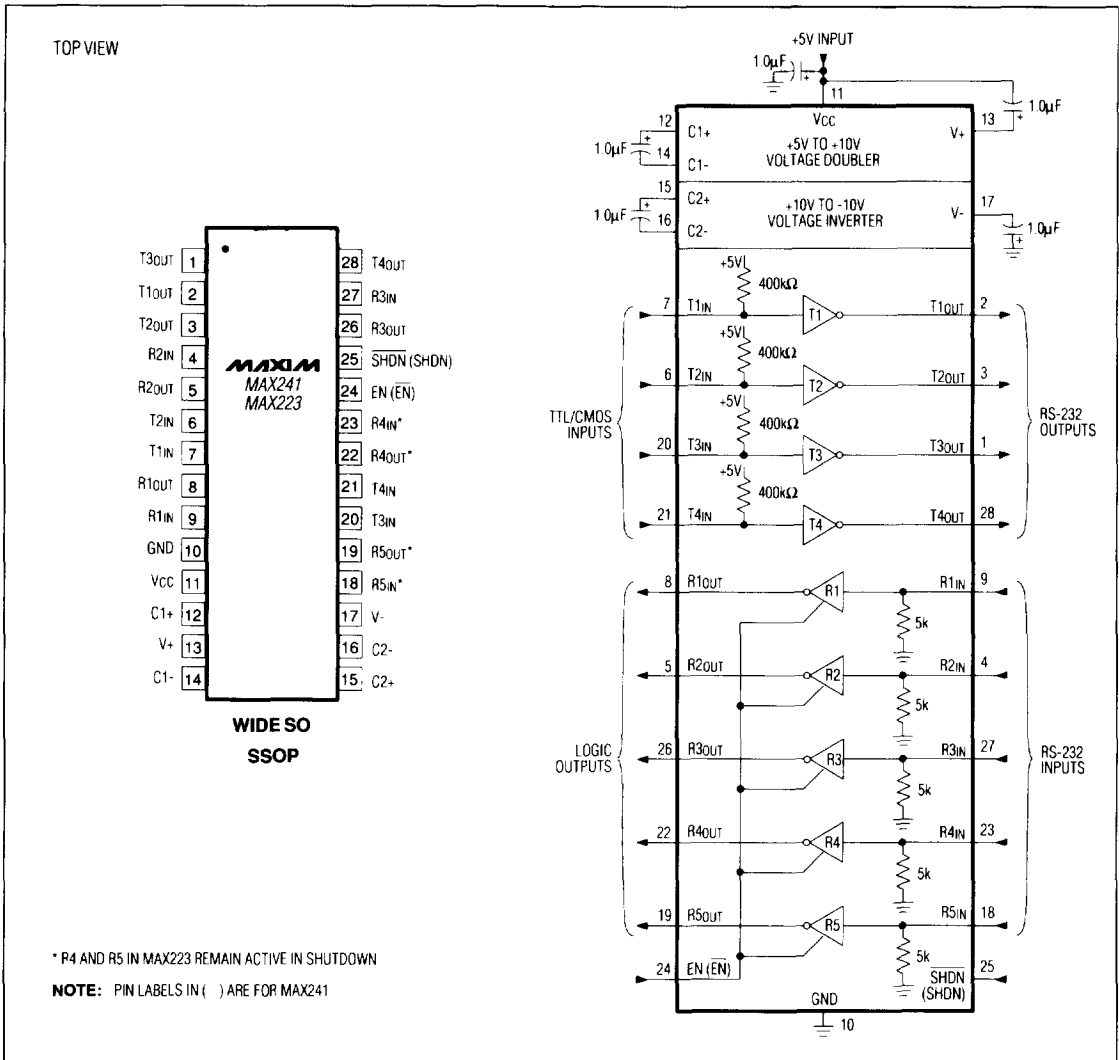

Figure 18. MAX241, MAX223 Pin Configuration and Typical Operating Circuit

# +5V-Powered, Multi-Channel RS-232 Drivers/Receivers

**MAX220-MAX249**

**2**

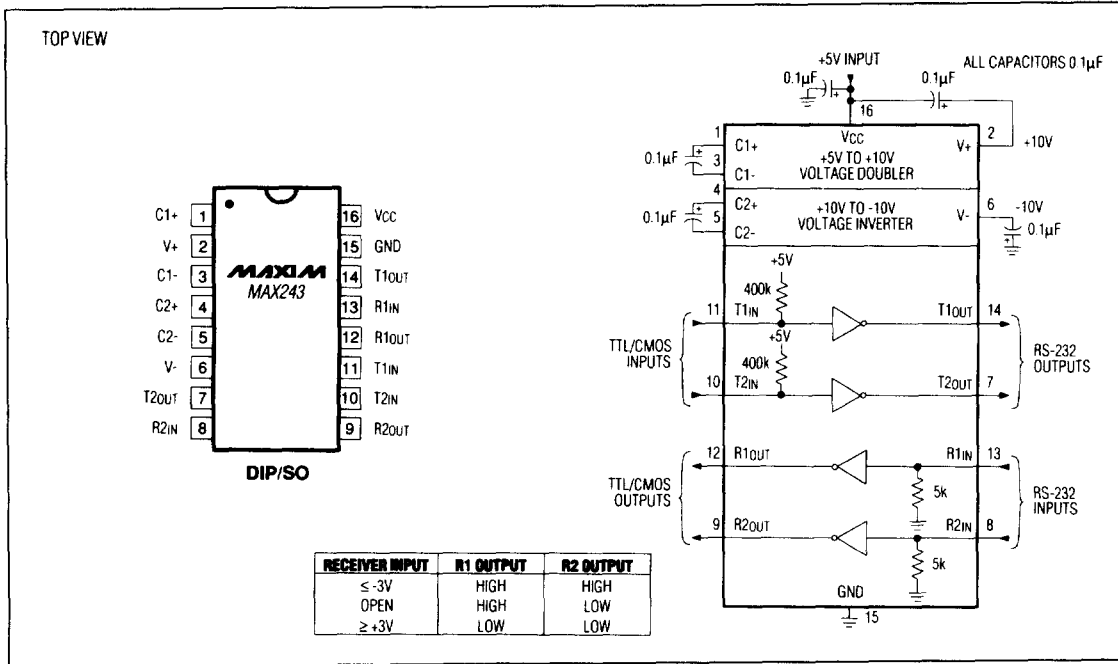

Figure 19. MAX243 Pin Configuration and Typical Operating Circuit

# +5V-Powered, Multi-Channel RS-232 Drivers/Receivers

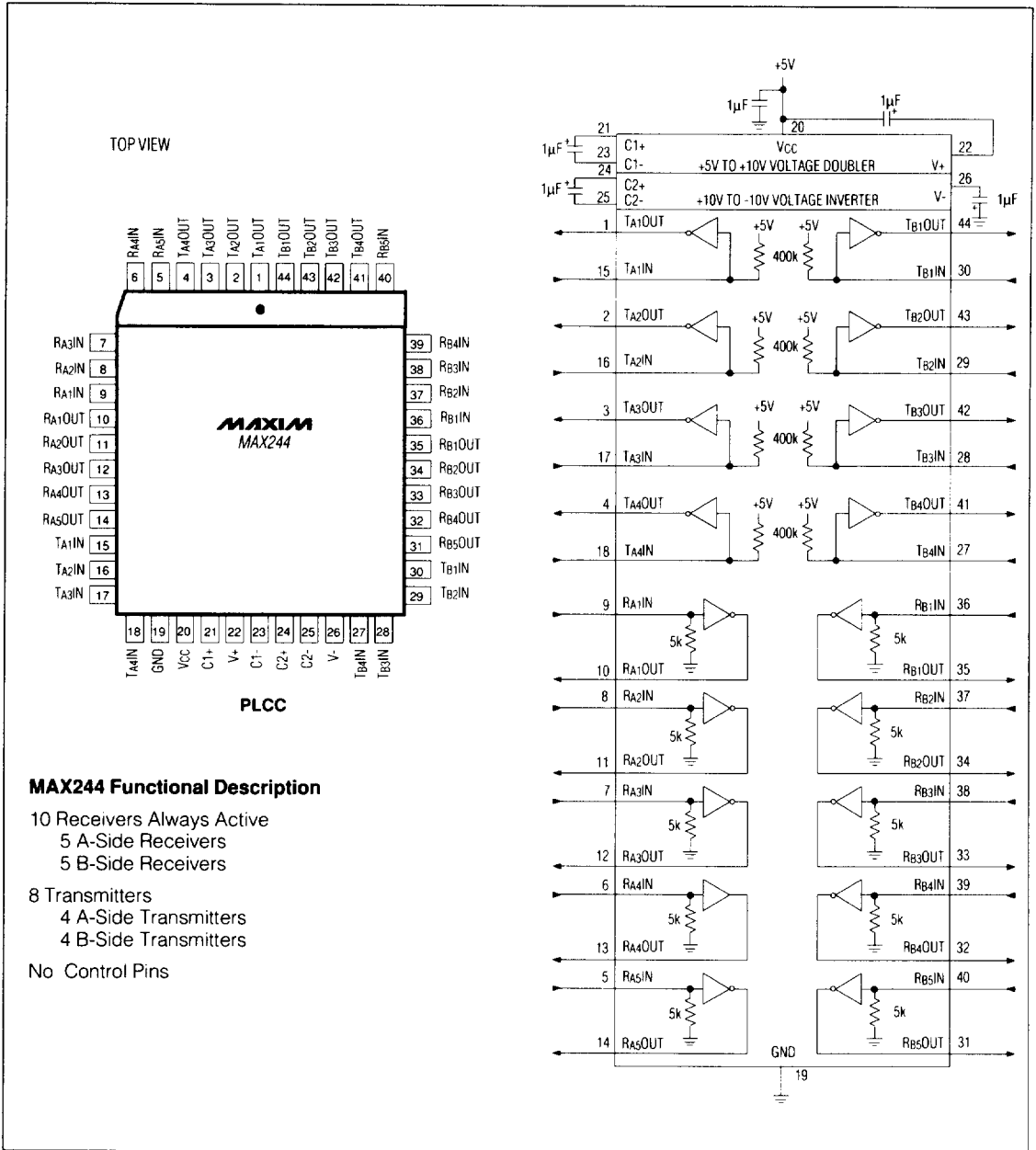

Figure 20. MAX244 Pin Configuration and Typical Operating Circuit

# +5V-Powered, Multi-Channel RS-232 Drivers/Receivers

**MAX220-MAX249**

**2**

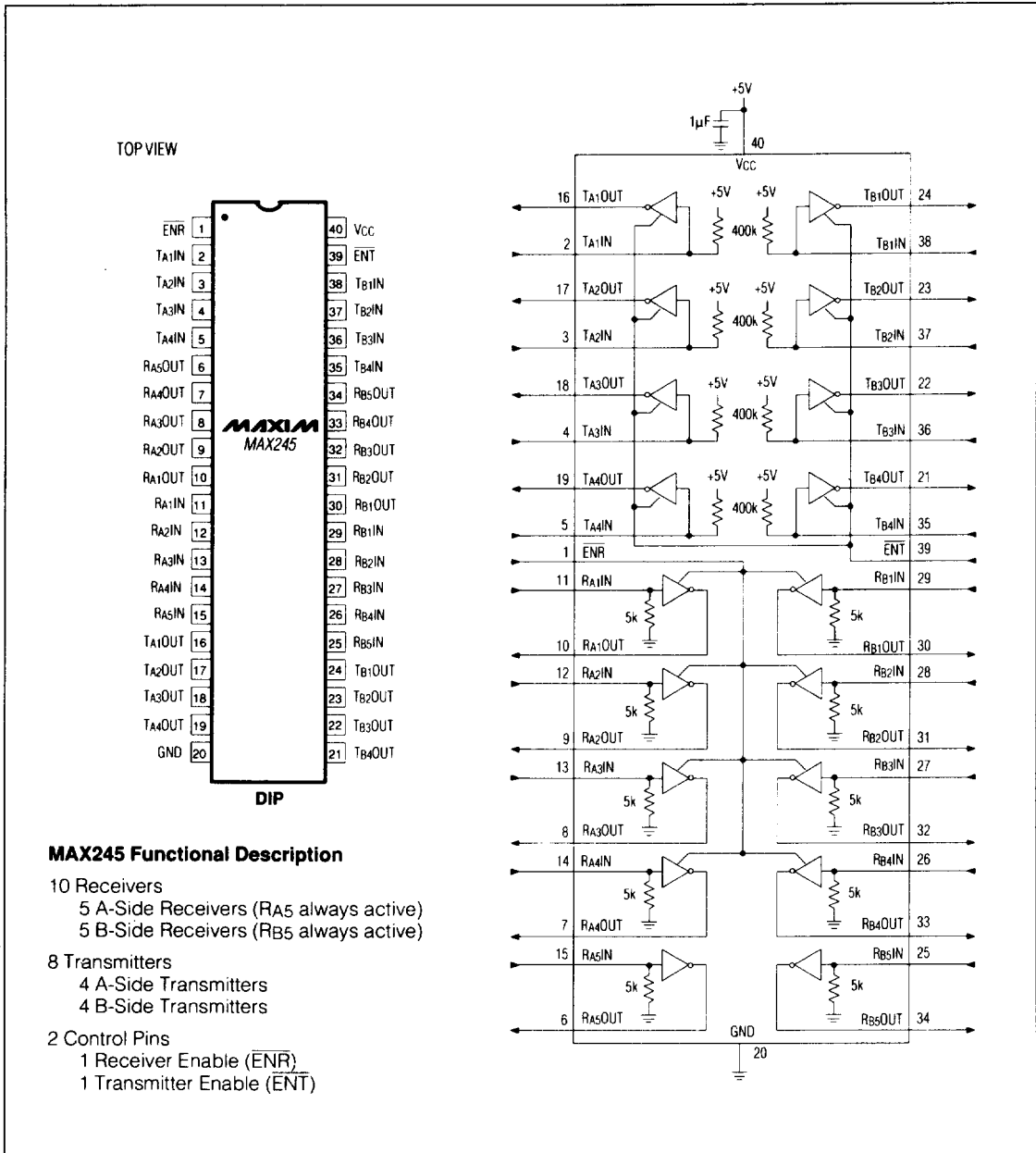
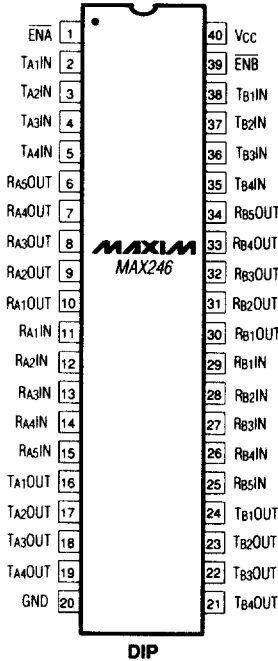

Figure 21. MAX245 Pin Configuration and Typical Operating Circuit

# +5V-Powered, Multi-Channel RS-232 Drivers/Receivers

TOP VIEW



### MAX246 Functional Description

- 10 Receivers
  - 5 A-Side Receivers (RA5 always active)
  - 5 B-Side Receivers (RB5 always active)
- 8 Transmitters
  - 4 A-Side Transmitters
  - 4 B-Side Transmitters
- 2 Control Pins
  - Enable A-Side (ENA)
  - Enable B-Side (ENB)

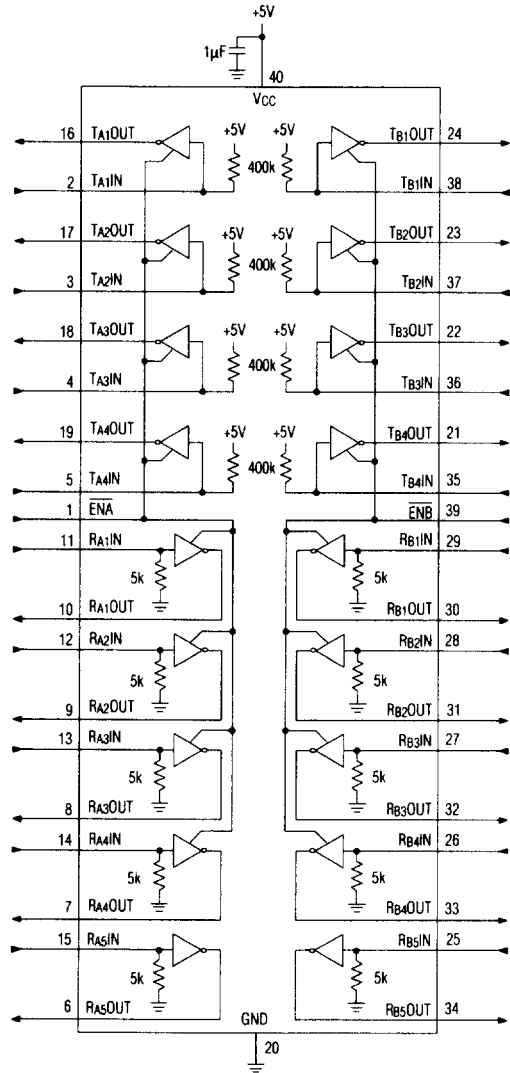

Figure 22. MAX246 Pin Configuration and Typical Operating Circuit

# +5V-Powered, Multi-Channel RS-232 Drivers/Receivers

**MAX220-MAX249**

2

TOP VIEW

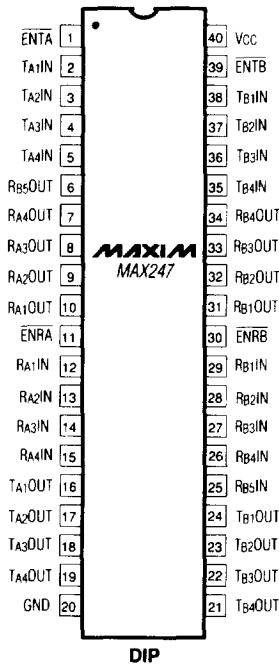

### MAX247 Functional Description

- 9 Receivers
  - 4 A-Side Receivers
  - 5 B-Side Receivers (Rb5 always active)
- 8 Transmitters
  - 4 A-Side Transmitters
  - 4 B-Side Transmitters
- 4 Control Pins
  - Enable Receiver A-Side (ENRA)
  - Enable Receiver B-Side (ENRB)
  - Enable Transmitter A-Side (ENTA)
  - Enable Transmitter B-Side (ENTB)

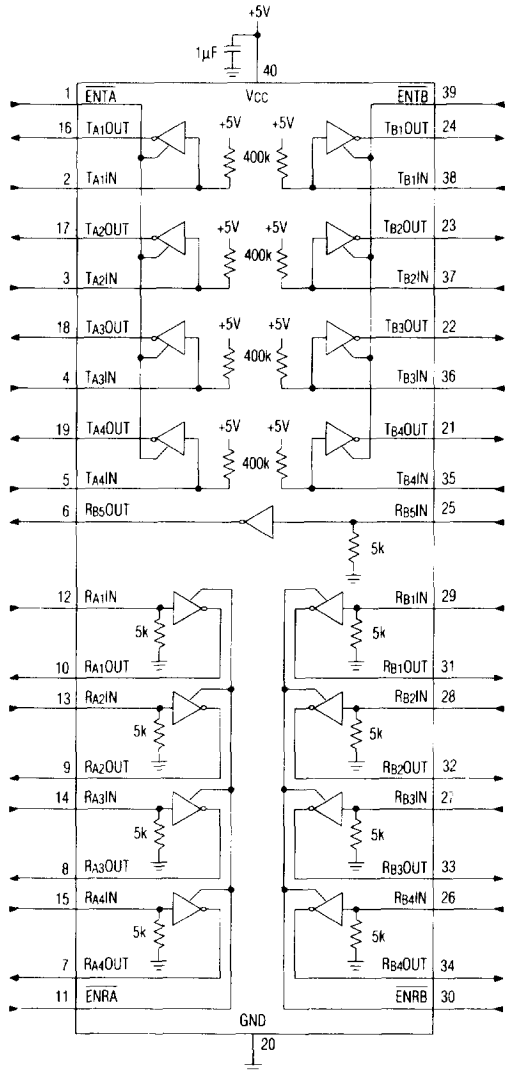

Figure 23. MAX247 Pin Configuration and Typical Operating Circuit

# +5V-Powered, Multi-Channel RS-232 Drivers/Receivers

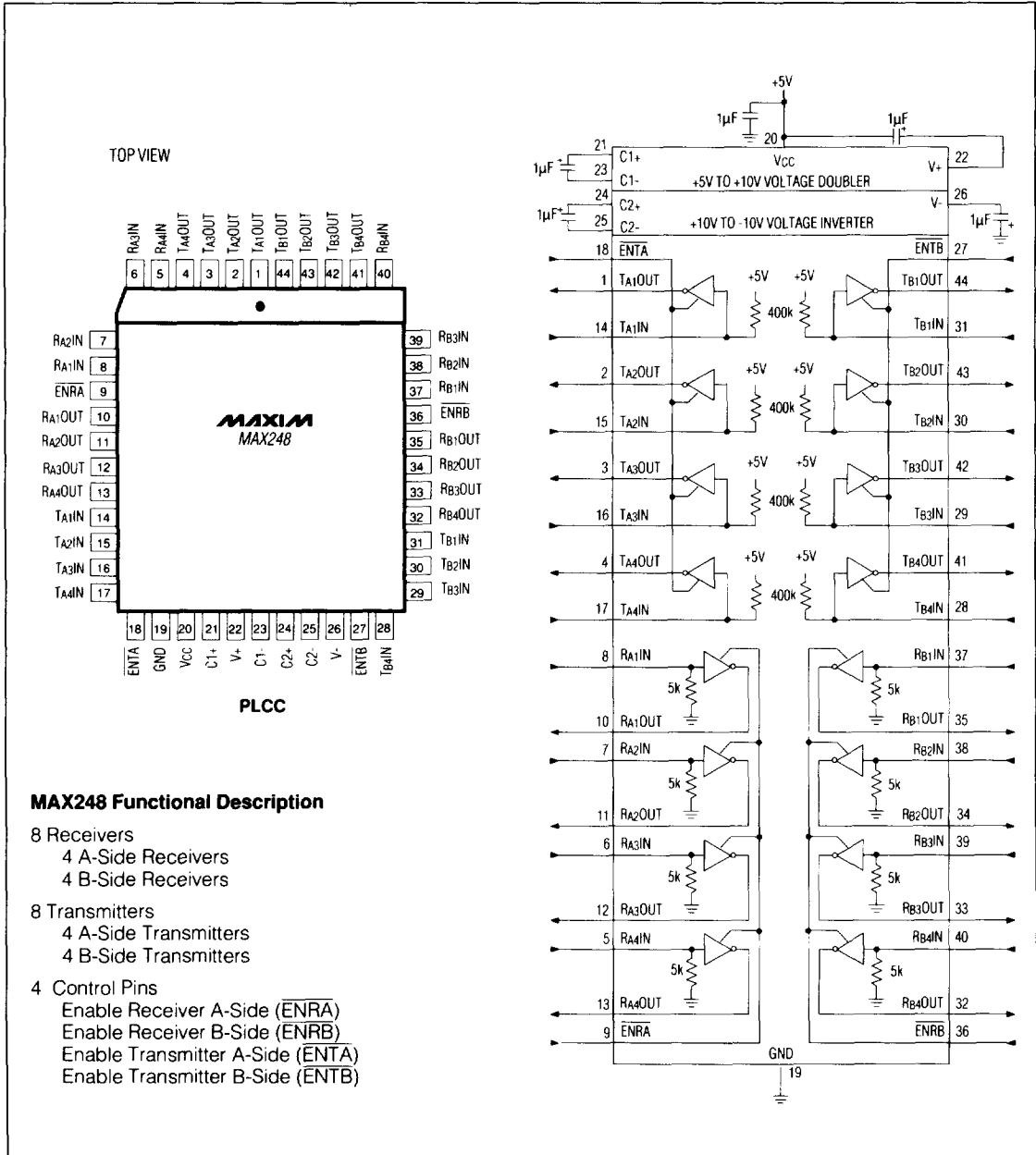

Figure 24. MAX248 Pin Configuration and Typical Operating Circuit



# +5V-Powered, Multi-Channel RS-232 Drivers/Receivers

**MAX220-MAX249**

**2**

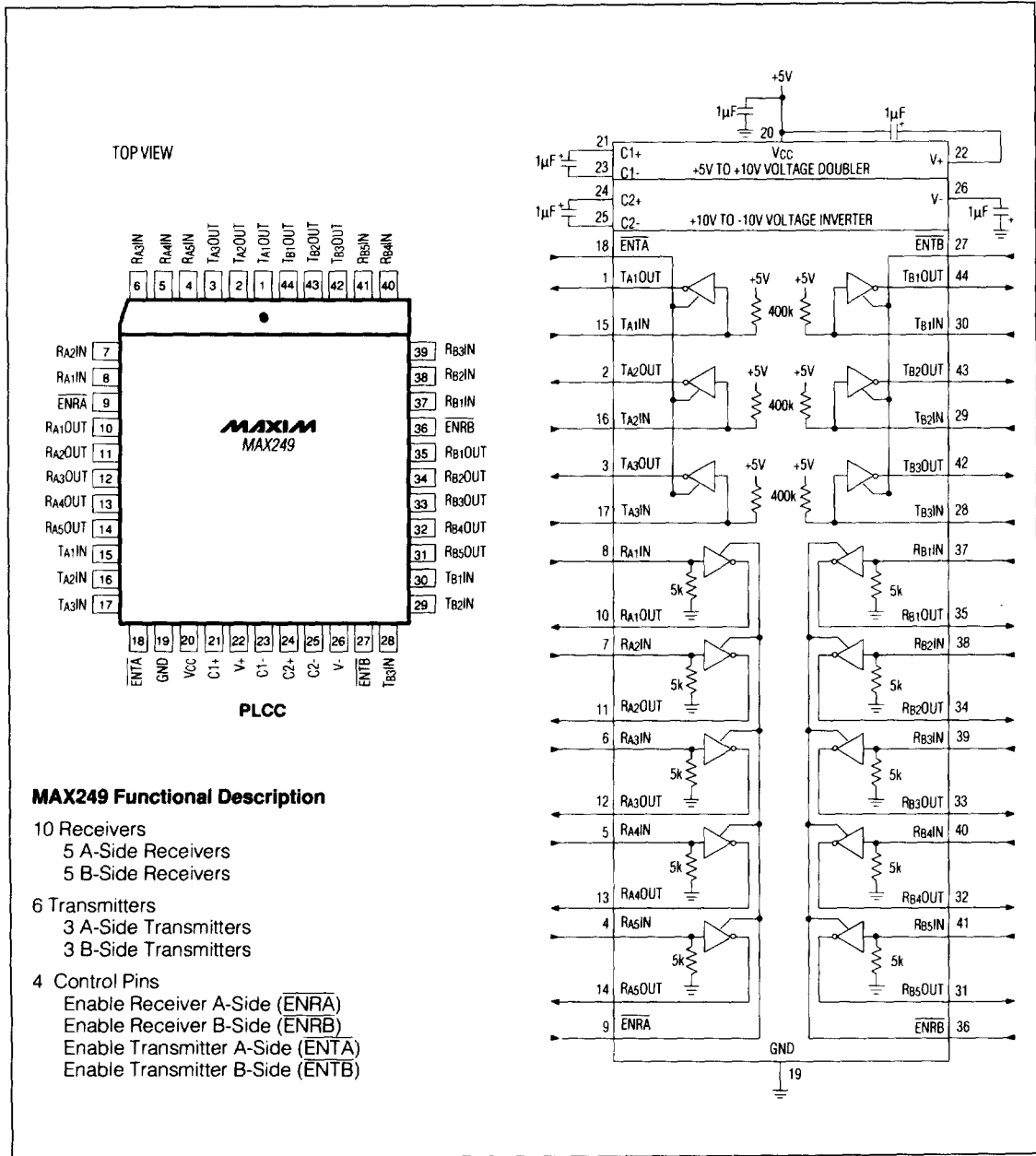

Figure 25. MAX249 Pin Configuration and Typical Operating Circuit

## +5V-Powered, Multi-Channel RS-232 Drivers/Receivers

### Ordering Information (continued)

PART	TEMP. RANGE	PIN-PACKAGE
MAX222CPN	0°C to +70°C	18 Plastic DIP
MAX222CWN	0°C to +70°C	18 Wide SO
MAX222C/D	0°C to +70°C	Dice*
MAX222EPN	-40°C to +85°C	18 Plastic DIP
MAX222EWN	-40°C to +85°C	18 Wide SO
MAX222EJN	-40°C to +85°C	18 CERDIP
MAX222MJN	-55°C to +125°C	18 CERDIP
MAX223CAI	0°C to +70°C	28 SSOP
MAX223CWI	0°C to +70°C	28 Wide SO
MAX223C/D	0°C to +70°C	Dice*
MAX223EAI	-40°C to +85°C	28 SSOP
MAX223EWI	-40°C to +85°C	28 Wide SO
MAX225CWI	0°C to +70°C	28 Wide SO
MAX225EWI	-40°C to +85°C	28 Wide SO
MAX230CPP	0°C to +70°C	20 Plastic DIP
MAX230CWP	0°C to +70°C	20 Wide SO
MAX230C/D	0°C to +70°C	Dice*
MAX230EPP	-40°C to +85°C	20 Wide SO
MAX230EWP	-40°C to +85°C	20 Wide SO
MAX230EJP	-40°C to +85°C	20 CERDIP
MAX230MJP	-55°C to +125°C	20 CERDIP
MAX231CPD	0°C to +70°C	14 Plastic DIP
MAX231CWE	0°C to +70°C	16 Wide SO
MAX231CJD	0°C to +70°C	14 CERDIP
MAX231C/D	0°C to +70°C	Dice*
MAX231EPD	-40°C to +85°C	14 Plastic DIP
MAX231EWE	-40°C to +85°C	16 Wide SO
MAX231EJD	-40°C to +85°C	14 CERDIP
MAX231MJD	-55°C to +125°C	14 CERDIP
MAX232CPE	0°C to +70°C	16 Plastic DIP
MAX232CSE	0°C to +70°C	16 Narrow SO
MAX232CWE	0°C to +70°C	16 Wide SO
MAX232C/D	0°C to +70°C	Dice*
MAX232EPE	-40°C to +85°C	16 Plastic DIP
MAX232ESE	-40°C to +85°C	16 Narrow SO
MAX232EWE	-40°C to +85°C	18 Wide SO
MAX232EJE	-40°C to +85°C	16 CERDIP
MAX232MJE	-55°C to +125°C	16 CERDIP
MAX232MLP	-55°C to +125°C	20 LCC
MAX232ACPE	0°C to +70°C	16 Plastic DIP
MAX232ACSE	0°C to +70°C	16 Narrow SO
MAX232ACWE	0°C to +70°C	16 Wide SO

MAX232AC/D	0°C to +70°C	Dice*
MAX232AEPE	-40°C to +85°C	16 Plastic DIP
MAX232AESE	-40°C to +85°C	16 Plastic SO
MAX232AEWE	-40°C to +85°C	18 Wide SO
MAX232AEJE	-40°C to +85°C	16 CERDIP
MAX232AMJE	-55°C to +125°C	16 CERDIP
MAX232AML P	-55°C to +125°C	20 LCC
MAX233CPP	0°C to +70°C	20 Plastic DIP
MAX233EPP	-40°C to +85°C	20 Plastic DIP
MAX233ACPP	0°C to +70°C	20 Plastic DIP
MAX233ACWP	0°C to +70°C	20 Wide SO
MAX233AEPP	-40°C to +85°C	20 Plastic DIP
MAX233AERP	-40°C to +85°C	20 Wide SO
MAX234CPE	0°C to +70°C	16 Plastic DIP
MAX234CWE	0°C to +70°C	16 Wide SO
MAX234C/D	0°C to +70°C	Dice*
MAX234EPE	-40°C to +85°C	16 Plastic DIP
MAX234EWE	-40°C to +85°C	16 Wide SO
MAX234EJE	-40°C to +85°C	16 CERDIP
MAX234MJP	-55°C to +125°C	16 CERDIP
MAX235CPG	0°C to +70°C	24 Wide Plastic DIP
MAX235EPG	-40°C to +85°C	24 Wide Plastic DIP
MAX235EDG	-40°C to +85°C	24 Ceramic SB
MAX235MDG	-55°C to +125°C	24 Ceramic SB
MAX236CNG	0°C to +70°C	24 Narrow Plastic DIP
MAX236CEG	0°C to +70°C	24 Wide SO
MAX236C/D	0°C to +70°C	Dice*
MAX236ENG	-40°C to +85°C	24 Narrow Plastic DIP
MAX236EWG	-40°C to +85°C	24 Wide SO
MAX236ERG	-40°C to +85°C	24 Narrow CERDIP
MAX236MRG	-55°C to +125°C	24 CERDIP
MAX237CNG	0°C to +70°C	24 Narrow Plastic DIP
MAX237CEG	0°C to +70°C	24 Wide SO
MAX237C/D	0°C to +70°C	Dice*
MAX237ENG	-40°C to +85°C	24 Narrow Plastic DIP
MAX237EWG	-40°C to +85°C	24 Wide SO
MAX237ERG	-40°C to +85°C	24 Narrow CERDIP
MAX237MRG	-55°C to +125°C	24 CERDIP
MAX238CNG	0°C to +70°C	24 Narrow Plastic DIP
MAX238CEG	0°C to +70°C	24 Wide SO
MAX238C/D	0°C to +70°C	Dice*
MAX238ENG	-40°C to +85°C	24 Narrow Plastic DIP

\*Contact factory for dice specifications.

# +5V-Powered, Multi-Channel RS-232 Drivers/Receivers

## Ordering Information (continued)

PART	TEMP. RANGE	PIN-PACKAGE
MAX238EWG	-40°C to +85°C	24 Wide SO
MAX238ERG	-40°C to +85°C	24 CERDIP
MAX238MRG	-55°C to +125°C	24 CERDIP
<b>MAX239CNG</b>	0°C to +70°C	24 Narrow Plastic DIP
MAX239CEG	0°C to +70°C	24 Wide SO
MAX239C/D	0°C to +70°C	Dice*
MAX239ENG	-40°C to +85°C	24 Narrow Plastic DIP
MAX239EWG	-40°C to +85°C	24 Wide SO
MAX239ERG	-40°C to +85°C	24 Narrow CERDIP
MAX239MRG	-55°C to +125°C	24 CERDIP
<b>MAX240CMH</b>	0°C to +70°C	44 Plastic FP
MAX240C/D	0°C to +70°C	Dice*
<b>MAX241CAI</b>	0°C to +70°C	28 SSOP
MAX241CWI	0°C to +70°C	28 Wide SO
MAX241C/D	0°C to +70°C	Dice*
MAX241EAI	-40°C to +85°C	28 SSOP
MAX241EWI	-40°C to +85°C	28 Wide SO
<b>MAX242CPN</b>	0°C to +70°C	18 Plastic DIP
MAX242CWN	0°C to +70°C	18 Wide SO
MAX242C/D	0°C to +70°C	Dice*
MAX242EPN	-40°C to +85°C	18 Plastic DIP
MAX242EWN	-40°C to +85°C	18 Wide SO
MAX242EJN	-40°C to +85°C	18 CERDIP
MAX242MJN	-55°C to +125°C	18 CERDIP

<b>MAX243CPE</b>	0°C to +70°C	16 Plastic DIP
MAX243CSE	0°C to +70°C	16 Narrow SO
MAX243CWE	0°C to +70°C	16 Wide SO
MAX243C/D	0°C to +70°C	Dice*
MAX243EPE	-40°C to +85°C	16 Plastic DIP
MAX243ESE	-40°C to +85°C	16 Narrow SO
MAX243EWE	-40°C to +85°C	16 Wide SO
MAX243EJE	-40°C to +85°C	16 CERDIP
MAX243MRG	-55°C to +125°C	16 CERDIP
<b>MAX244CQH</b>	0°C to +70°C	44 PLCC
MAX244C/D	0°C to +70°C	Dice*
MAX244EQH	-40°C to +85°C	44 PLCC
<b>MAX245CPL</b>	0°C to +70°C	40 Plastic DIP
MAX245C/D	0°C to +70°C	Dice*
MAX245EPE	-40°C to +85°C	40 Plastic DIP
<b>MAX246CPL</b>	0°C to +70°C	40 Plastic DIP
MAX246C/D	0°C to +70°C	Dice*
MAX246EPE	-40°C to +85°C	40 Plastic DIP
<b>MAX247CPL</b>	0°C to +70°C	40 Plastic DIP
MAX247C/D	0°C to +70°C	Dice*
MAX247EPL	-40°C to +85°C	40 Plastic DIP
<b>MAX248CQH</b>	0°C to +70°C	44 PLCC
MAX248C/D	0°C to +70°C	Dice*
MAX248EQH	-40°C to +85°C	44 PLCC
<b>MAX249CQH</b>	0°C to +70°C	44 PLCC
MAX249EQH	-40°C to +85°C	44 PLCC

\*Contact factory for dice specifications.

**MAX220-MAX249**

**2**

# +5V-Powered, Multi-Channel RS-232 Drivers/Receivers

## Chip Topographies

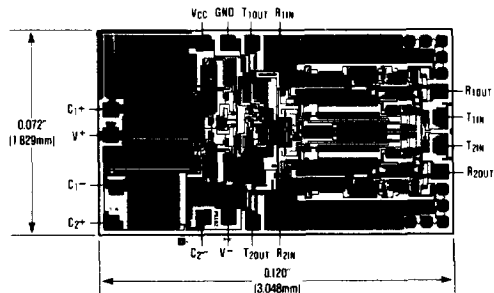

**MAX231, MAX232 and MAX233**

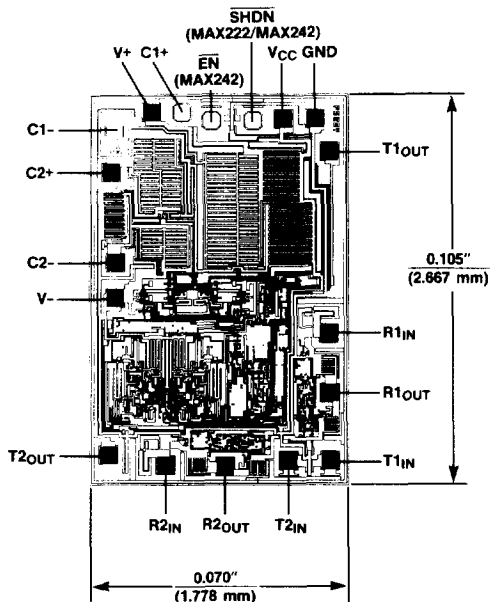

**MAX220/222/232A/233A/242/243**

CONNECT SUBSTRATE TO V+

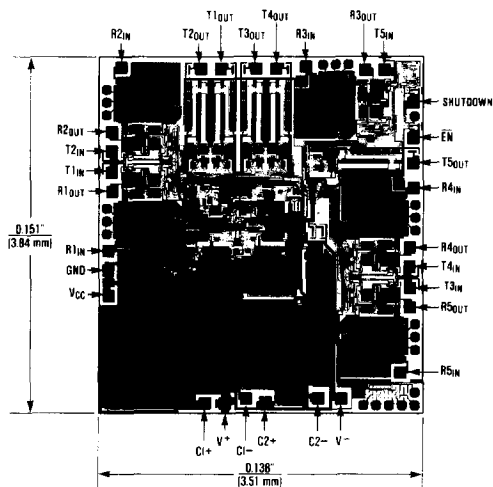

**MAX230 and MAX234-239, MAX240, MAX241**

SHUTDOWN PIN OF MAX234, MAX237, MAX238, MAX239, MAX240 AND MAX241 ARE INTERNALLY CONNECTED TO GROUND.

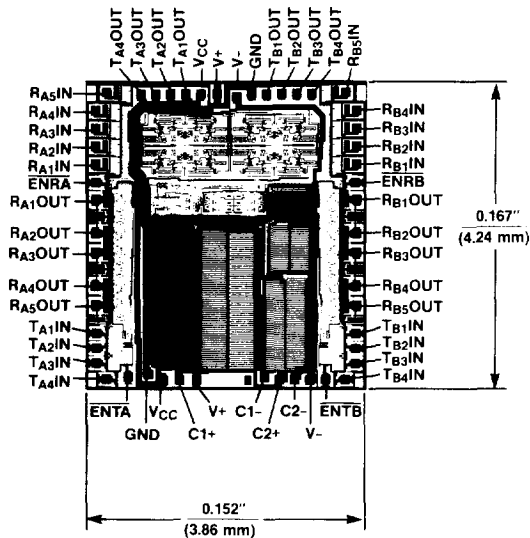

**MAX244/245/246/247/248/249**