

Preliminary Technical Data (Rev. 0.1, June 22, 2000)

**HITACHI**

## TRM7954AN

---

STM-16 1.5  $\mu\text{m}$  Optical Transmitter (for 50 GHz Spacing DWDM)

---

### **Preliminary Product Disclaimer**

This preliminary data sheet is provided to assist you in the evaluation of functional samples of the products that are under development and for which a reliability test has not been completed. Until Hitachi, Ltd. releases these products for general sales, Hitachi, Ltd. reserves the right to change prices, features, functions, specifications, capabilities and release schedule.

---

### **FEATURES**

---

- **Data rates up to 2.5 Gbit/s**
- **Long-haul Transmission Length (400 km)**
- **Wavelength range, 1530.72 nm – 1562.23 nm**
- **ITU-Grid Channel (50 GHz Spacing)**
- **Compact size (51 x 73.4 x 12.7 mm<sup>3</sup>)**
- **Integrated Wavelength Lock Mechanism**
- **Laser bias monitor output**
- **Laser back-facet monitor output**
- **Laser Temperature Deviation Alarm**

### Block Diagram

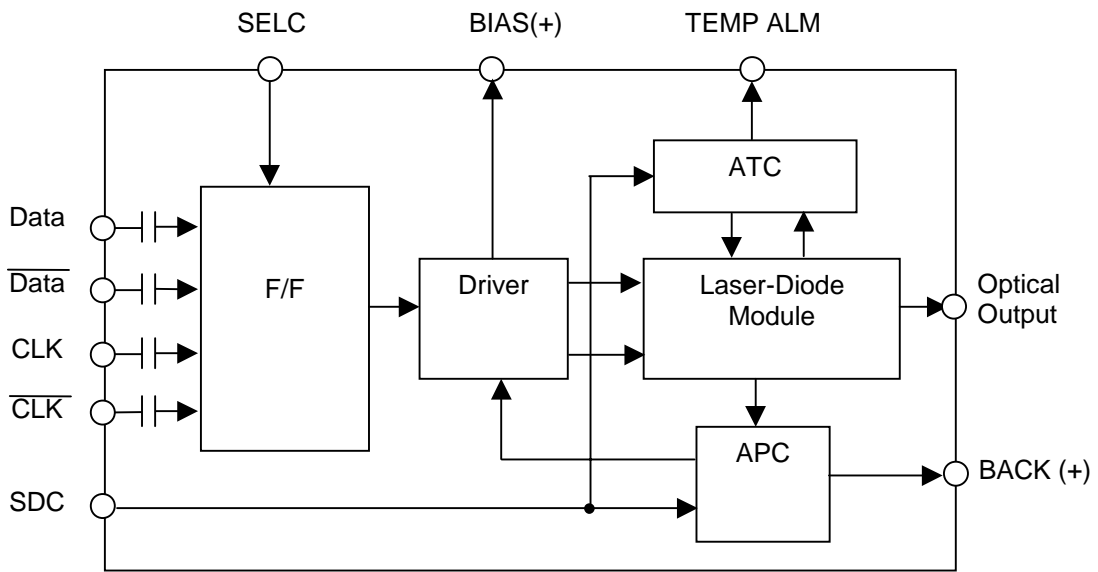

### Recommended Circuit

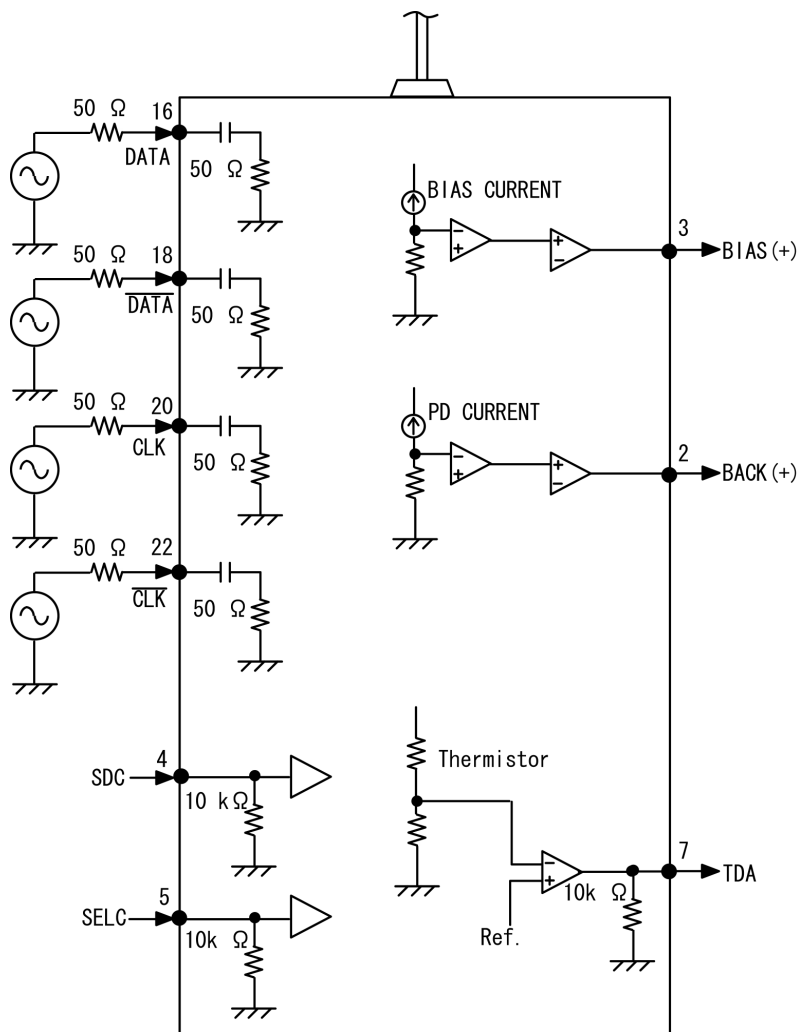

**PERFORMANCE SPECIFICATIONS**

Table 1. Absolute Maximum Ratings

No.	Item	Symbol	Rated Value	Unit	Note
1	DC Power Supply (+5.0 V)	-	-0.3 to +6.0	V	Vcc
2	DC Power Supply (-5.2 V)	-	-6.0 to +0.3	V	Vee
3	DC Power Supply (+3.3 V)	-	-0.3 to +4.0	V	Vtt
4	Operating Case Temperature	Topr.	0 to +70	°C	
5	Storage Case Temperature	Tstg.	-20 to +75	°C	
6	Lead Soldering Temperature	-	≤250	°C	
7	Lead Soldering Time	-	≤10	s	

Table 2. Operating Environment

Electrical and optical characteristics below are defined under this operating environment, unless otherwise specified.

No.	Parameter	Symbol	Min.	Typ.	Max.	Unit	Remarks
1	Supply Voltage	V <sub>CC</sub>	4.75	5.0	5.25	V	
2	Supply Voltage	V <sub>DD</sub>	3.13	3.3	3.47	V	
3	Supply Voltage	V <sub>EE</sub>	-4.94	-5.2	-5.45	V	
4	Supply Current	I <sub>CC</sub>	-	-	0.8	A	+5 V
5	Supply Current	I <sub>DD</sub>	-	-	2.0	A	+3.3 V
6	Supply Current	I <sub>EE</sub>	-	-	1.8	A	-5.2 V
7	Power Consumption	P <sub>DS</sub>	-	-	14	W	
8	Operating Temperature	T <sub>C</sub>	(Note)	25	(Note)	°C	Case

Note: Target specification is minimum of 0 and maximum of 65.

Table 3. DC Power Supply

No.	Item	Symbol	Min.	Typ.	Max.	Unit
1	Positive Supply Voltage	Vcc	+4.75	+5.00	+5.25	V
2	Negative Supply Voltage	Vee	-4.94	-5.20	-5.46	V
3	TEC Supply Voltage	Vtt	+3.15	+3.30	+3.45	V
4	Positive Supply Current	Icc	-	-	400	mA
5	Negative Supply Current	Iee	-	-	250	mA
6	TEC Supply Current	Itt	-	-	1300	mA
7	Total Power Consumption	Pc	-	-	6.5	W

Table 4. Optical Characteristics

No.	Item	Symbol	Min.	Typ.	Max.	Unit	Remarks (Note 1)
1	Average Power Output	Pf	-3.5 -4.5	- -	+2.0 +2.0	dBm	Point S, Beginning of life Point S, End of life
2	Extinction Ratio	ER	10	-	-	dB	
3	Optical Waveform	-	Satisfying the Mask			-	Note 2
4	Optical Output at Shutdown	-	-	-	-40	dBm	
5	Center Wavelength	$\lambda_c$	1528.77	-	1563.86	nm	50 GHz Spacing
6	Variation in Center Wavelength	$\Delta\lambda$	-0.04		+0.04	nm	End of Life, TBD
7	Spectral Width (-20 dB)	$\Delta\lambda_{20}$	-	-	0.5	nm	
8	Side-mode Suppression Ratio	Sr	30	-	-	dB	
9	Optical Path Penalty	Pp	-	-	2	dB	6400 ps/nm, Note 3

Note 1. Transmit Data: NRZ at 2.488320 Gbit/s, Mark 50%, PRBS= $2^{23}-1$ ,  
Power Supply Voltage:  $V_{cc} = 5.0^{+0.25}$  V,  $V_{ee} = -5.2^{+0.26}$  V,  $V_{tt} = 3.3^{+0.16}$   
 $T_c = 0$  to  $75^\circ\text{C}$

Note 2.

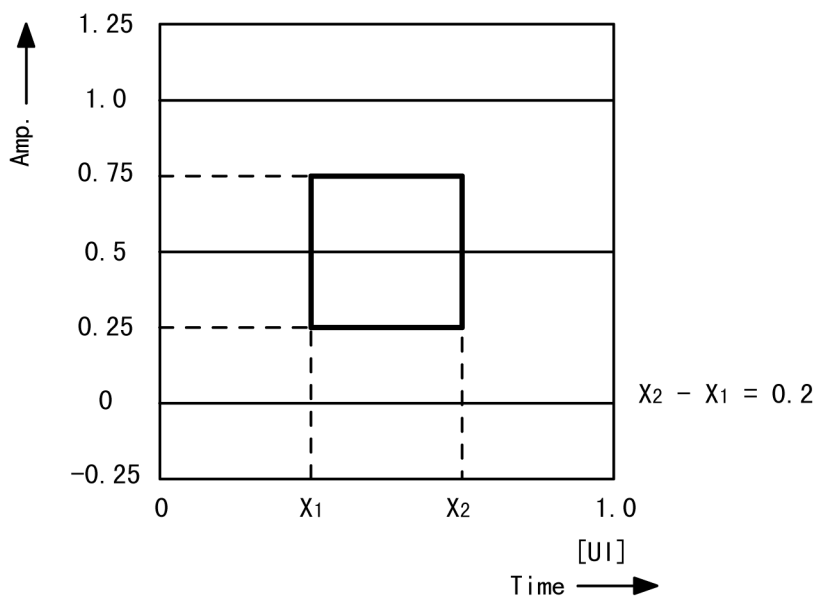

Fig. 4.1 Mask of Eye Diagram for the Optical Waveform through the 4<sup>th</sup>-order Bessel Filter According to ITU-T G957

Note 3.

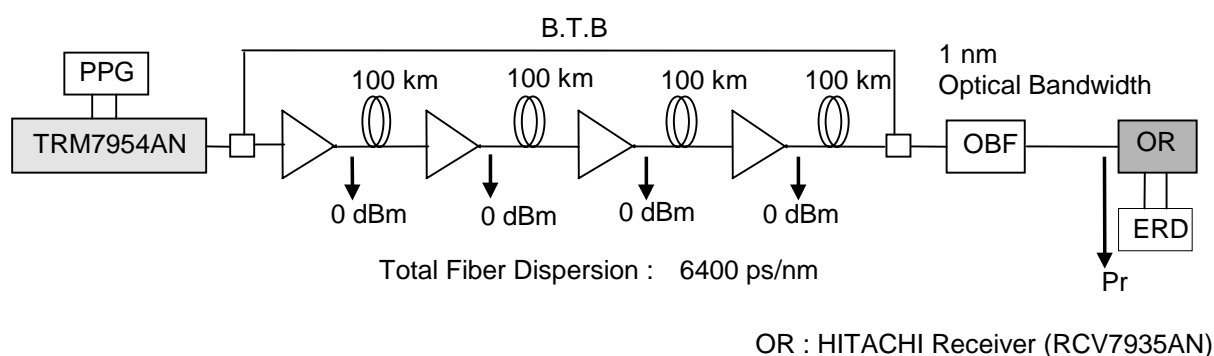

Fig 4.2 Optical Path Penalty Measurement Setup

Table 5 Input/Output Signal Interface

No.	Item	Min.	Typ.	Max.	Unit	Remarks (Note 1)	
1	Optical Connector	FC-PC			-		
2	Data Input Impedance	50			$\Omega$	AC-coupled	
3	Input Data Voltage	Single	500	-	1000	mV	peak to peak
		Differential	300	-	1000		
4	Clock Input Impedance	50			$\Omega$	AC-coupled	
5	Input Clock Voltage	Single	500	-	1000	mV	peak to peak
		Differential	300	-	1000		
6	Input Clock Duty Cycle	40	50	60	%		
7	Setup time and Hold time	-	-	75	ps	Note 2	
8	Shutdown Command Interface	TTL Level Active High			-	Note 3	
9	Shutdown activation time	-	-	5	ms		
10	Shutdown deactivation time	-	-	250	ms		
11	Clock Mode Select Interface	TTL Level: High: Non-clocked mode Low: Clocked mode			-	Note 4	
12	Temperature Deviation Alarm	TTL Level Active High			-	Note 5	
13	Monitoring for LD bias current (BIAS(+))	-	20	-	mV/mA		
14	Monitoring for back facet PD current (BACK(+))	450	500	550	mV	Note 6	

Note 1 Transmit Data: NRZ at 2.488320 Gbit/s, Mark 50%, PRBS=2<sup>23</sup>-1,  
 Power Supply Voltage: Vcc = 5.0<sup>+0.25</sup> V, Vee = -5.2<sup>+0.26</sup> V, Vtt = 3.3<sup>+0.16</sup>  
 Tc = 0 to 75°C

Note 2.

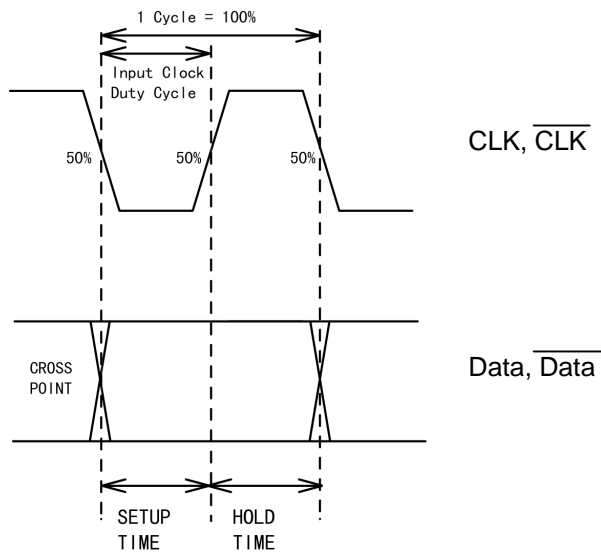

Fig. 5.1 Setup Time and Hold Time

Note 3.

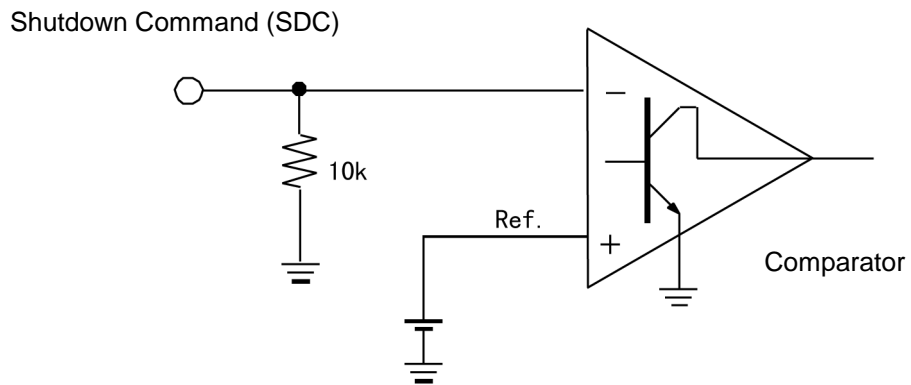

Fig. 5.2 Shutdown Command Interface

Note 4.

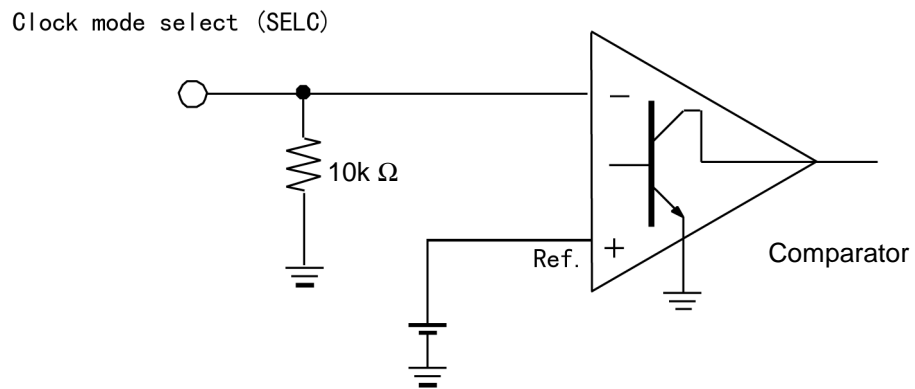

Fig. 5.3 Clock Mode Select Interface

Note 5.

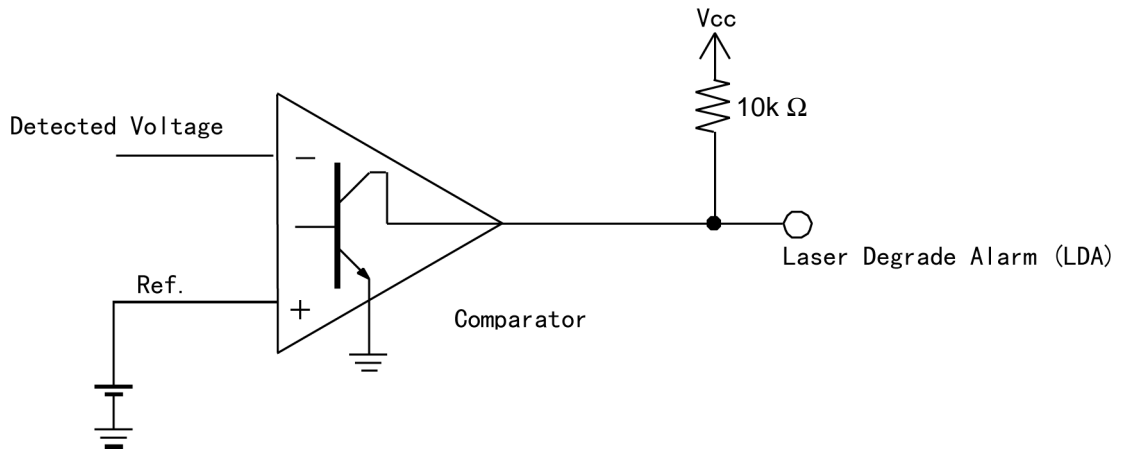

Fig. 5.4 Temperature Deviation Alarm Interface

Note 6.

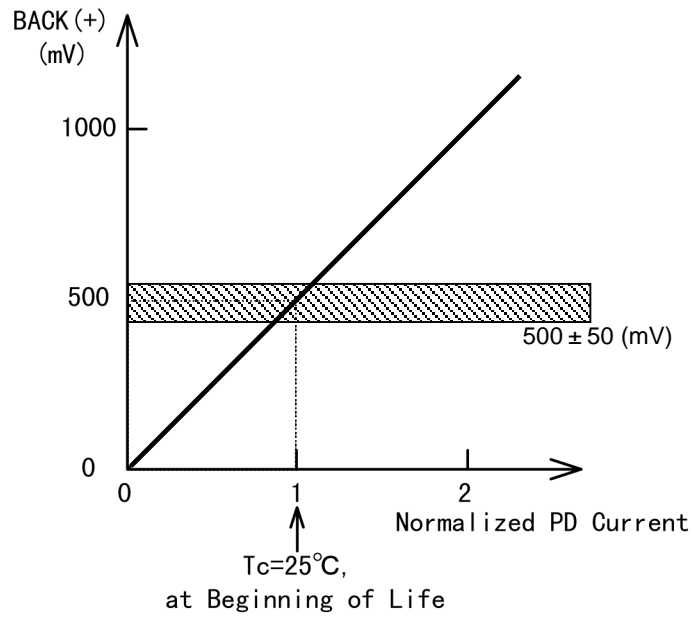

Fig. 5.5 Monitoring for Back Facet PD Activation



Table 6. Pin Configuration

Pin #	Symbol	I/O	Logic	Description	Remarks
1	GND			Ground	
2	BACK(+)			Monitoring for back facet PD current	
3	BIAS(+)			Monitoring for LD bias current	
4	SDC			Shutdown Command	
5	SELC			Clock mode select	
6	GND			Ground	
7	TDA			Temperature Deviation Alarm	
8	NUC			No User Connection	
9	NUC			No User Connection	
10	NUC			No User Connection	
11	GND			Ground	
12	Vee			Negative power supply	
13	Vcc			Positive power supply	
14	Vtt			TEC power supply	
15	GND			Ground	
16	DATA			True data input	
17	GND			Ground	
18	$\overline{\text{DATA}}$			False data input	
19	GND			Ground	
20	CLK			True clock input	
21	GND			Ground	
22	$\overline{\text{CLK}}$			False clock input	
23	GND			Ground	
24	Vcc			Positive power supply	
				Metal Case is at GND.	

### Mechanical Dimensions

Dimensions: mm  
Tolerance :  $\pm 0.5$  mm

Top view

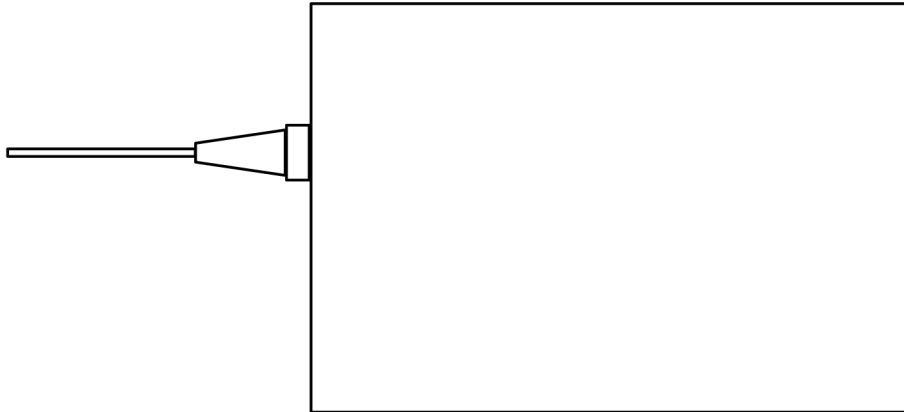

Side view

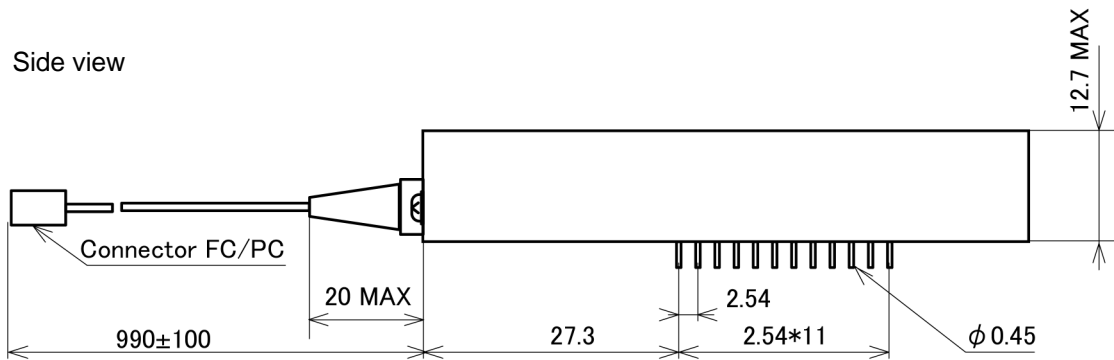

Bottom view

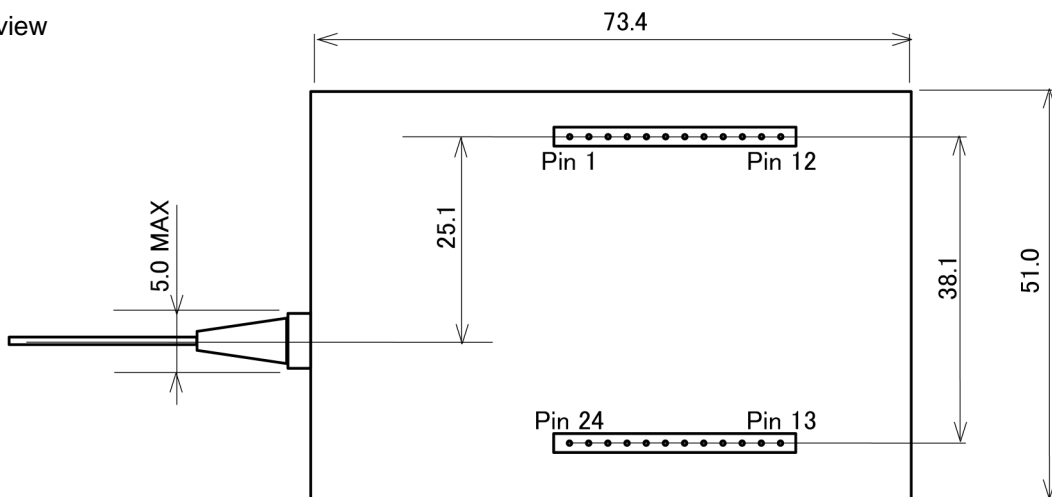

Table 6. Optical Fiber

No.	Item	Specifications	Unit
1	Type	SMF	-
2	Mode Field Diameter	$9.5 \pm 1$	$\mu\text{m}$
3	Cladding Diameter	$125 \pm 3$	$\mu\text{m}$
4	Minimum Bending Radius	30	mm
5	Fiber Tensile Strength	9.8	N
5	Outer Diameter of Secondary Coating	$0.9 \pm 0.1$	mm

Table 7. Ordering Information

No.	Production Code	Center Wavelength (nm)	No.	Production Code	Center Wavelength (nm)
01	TRM7954AN3072	1530.72	41	TRM7954AN4662	1546.62
02	TRM7954AN3112	1531.12	42	TRM7954AN4692	1546.92
03	TRM7954AN3151	1531.51	43	TRM7954AN4732	1547.32
04	TRM7954AN3190	1531.90	44	TRM7954AN4772	1547.72
05	TRM7954AN3229	1532.29	45	TRM7954AN4811	1548.11
06	TRM7954AN3268	1532.68	46	TRM7954AN4851	1548.51
07	TRM7954AN3307	1533.07	47	TRM7954AN4891	1548.91
08	TRM7954AN3347	1533.47	48	TRM7954AN4932	1549.32
09	TRM7954AN3386	1533.86	49	TRM7954AN4972	1549.72
10	TRM7954AN3425	1534.25	50	TRM7954AN5012	1550.12
11	TRM7954AN3464	1534.64	51	TRM7954AN5052	1550.52
12	TRM7954AN3504	1535.04	52	TRM7954AN5092	1550.92
13	TRM7954AN3543	1535.43	53	TRM7954AN5132	1551.32
14	TRM7954AN3582	1535.82	54	TRM7954AN5172	1551.72
15	TRM7954AN3622	1536.22	55	TRM7954AN5212	1552.12
16	TRM7954AN3661	1536.61	56	TRM7954AN5252	1552.52
17	TRM7954AN3700	1537.00	57	TRM7954AN5293	1552.93
18	TRM7954AN3740	1537.40	58	TRM7954AN5333	1553.33
19	TRM7954AN3779	1537.79	59	TRM7954AN5373	1553.73
20	TRM7954AN3819	1538.19	60	TRM7954AN5413	1554.13
21	TRM7954AN3858	1538.58	61	TRM7954AN5454	1554.54
22	TRM7954AN3898	1538.98	62	TRM7954AN5494	1554.94
23	TRM7954AN3937	1539.37	63	TRM7954AN5534	1555.34
24	TRM7954AN3977	1539.77	64	TRM7954AN5575	1555.75
25	TRM7954AN4016	1540.16	65	TRM7954AN5615	1556.15
26	TRM7954AN4056	1540.56	66	TRM7954AN5655	1556.55
27	TRM7954AN4095	1540.95	67	TRM7954AN5696	1556.96
28	TRM7954AN4135	1541.35	68	TRM7954AN5736	1557.63
29	TRM7954AN4175	1541.75	69	TRM7954AN5777	1557.77
30	TRM7954AN4214	1542.14	70	TRM7954AN5817	1558.17
31	TRM7954AN4254	1542.54	71	TRM7954AN5858	1558.58
32	TRM7954AN4294	1542.94	72	TRM7954AN5898	1558.98
33	TRM7954AN4333	1543.33	73	TRM7954AN5939	1559.39
34	TRM7954AN4373	1543.73	74	TRM7954AN5979	1559.79
35	TRM7954AN4413	1544.13	75	TRM7954AN6020	1560.20
36	TRM7954AN4453	1544.53	76	TRM7954AN6061	1560.61
37	TRM7954AN4492	1544.92	77	TRM7954AN6101	1561.01
38	TRM7954AN4532	1545.32	78	TRM7954AN6142	1561.42
39	TRM7954AN4572	1545.72	79	TRM7954AN6183	1561.83
40	TRM7954AN4612	1546.12	80	TRM7954AN6223	1562.23

---

## USER INFORMATION

---

### Handling Precautions

CAUTION: Take proper electrostatic-discharge (ESD) precautions while handling these devices. These devices are sensitive to ESD.

### Laser Safety

This product complies with IEC 60825-1 Class 1.

**HITACHI**Document number: **FOD-DS-00058**

Document Category: Product Specifications (Data Sheet)

Revision: 0.1 (June 2000)

Product Name: TRM7954AN

---

**STM-16 1.5  $\mu\text{m}$  Optical Transmitter (for 50 GHz Spacing DWDM)**  
**TRM7954AN**

---

**Revision History**

Rev.	Date	Page/Line/Fig/Table	Modification	Note
0.1	June 22, 2000	-	-	