

μA740

FET INPUT OPERATIONAL AMPLIFIER

FAIRCHILD LINEAR INTEGRATED CIRCUITS

GENERAL DESCRIPTION — The μA740 is a high performance monolithic FET Input Operational Amplifier constructed using the Fairchild Planar* epitaxial process. It is intended for a wide range of analog applications where very high input impedance is required and features very low input offset current and very low input bias current. High slew rate, high common mode voltage range and absence of latch-up make the μA740 ideal for use as a voltage follower. The high gain and wide range of operating voltages provide superior performance in active filters, integrators, summing amplifiers, sample-and-hold circuits, transducer amplifiers, and other general feedback applications. The μA740 is short circuit protected and has the same pin configuration as the popular μA741 operational amplifier. No external components for frequency compensation are required as the internal 6 dB/octave roll-off insures stability in closed loop applications.

- HIGH INPUT IMPEDANCE . . . 1,000,000 MΩ
- NO FREQUENCY COMPENSATION REQUIRED
- SHORT-CIRCUIT PROTECTION
- OFFSET VOLTAGE NULL CAPABILITY
- LARGE COMMON-MODE AND DIFFERENTIAL VOLTAGE RANGES
- NO LATCH UP

ABSOLUTE MAXIMUM RATINGS

Supply Voltage	±22V
Internal Power Dissipation (Note 1)	500mW
Differential Input Voltage	±30V
Input Voltage (Note 2)	±15V
Voltage between Offset Null and V+	±0.5V
Storage Temperature Range	-65°C to +150°C
Operating Temperature Range	
Military (μA740)	-55°C to +125°C
Commercial (μA740C)	0°C to +70°C
Lead Temperature (Soldering, 60 seconds)	300°C
Output Short-Circuit Duration (Note 3)	Indefinite

CONNECTION DIAGRAM

8-LEAD METAL CAN
(TOP VIEW)
PACKAGE OUTLINE 5S
PACKAGE CODE H

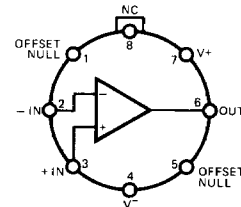

NOTE: Pin 4 Connected to Case.

ORDER INFORMATION

TYPE	PART NO.
μA740	μA740HM ✓
μA740C	μA740HC ✓

EQUIVALENT CIRCUIT

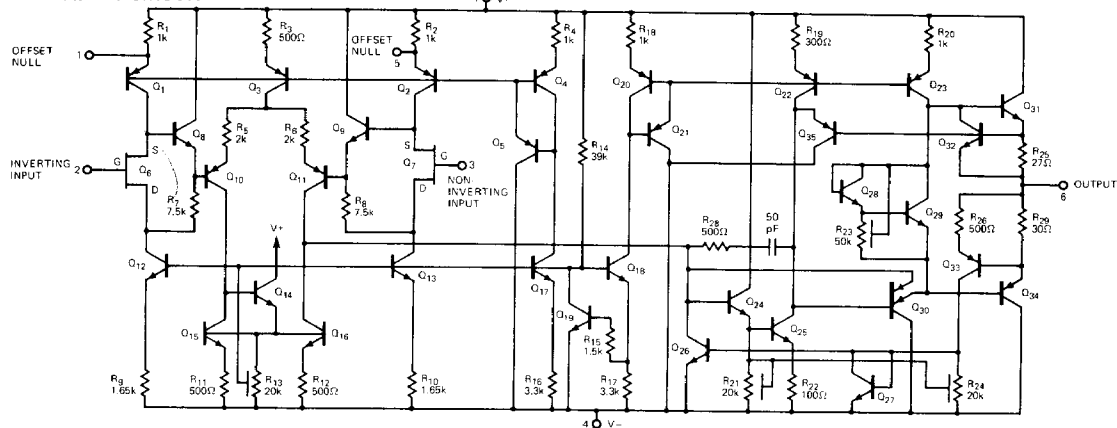

Notes on following pages.

*Planar is a patented Fairchild process.

$\mu A740$

ELECTRICAL CHARACTERISTICS ($V_S = \pm 15V$, $T_C = 25^\circ C$ unless otherwise specified)

PARAMETER	CONDITIONS	MIN	TYP	MAX	UNITS	
Input Offset Voltage	$R_S \leq 100\text{ k}\Omega$		10	20	mV	
Input Offset Current [Note 4]			40	150	pA	
Input Current (either input) [Note 4]			100	200	pA	
Input Resistance			1,000,000		M Ω	
Large Signal Voltage Gain	$R_L \geq 2\text{ k}\Omega$, $V_{OUT} = \pm 10V$	50,000	1,000,000		V/V	
Output Resistance			75		Ω	
Output Short Circuit Current			20		mA	
Common Mode Rejection Ratio		64	80		dB	
Supply Voltage Rejection Ratio			70	300	$\mu V/V$	
Supply Current			4.2	5.2	mA	
Power Consumption			126	156	mW	
Slew Rate			6.0		V/ μs	
Unity Gain Bandwidth			3.0		MHz	
Transient Response (Unity Gain)	Rise Time	$C_L \leq 100\text{ pF}$, $R_L = 2\text{ k}\Omega$, $V_{IN} = 100\text{ mV}$		110		ns
	Overshoot			10	20	%

The following specifications apply for $T_C = -55^\circ C$ to $+85^\circ C$:

Input Voltage Range		± 10		± 12	V
Large Signal Voltage Gain	$R_L \geq 2\text{ k}\Omega$, $V_{OUT} = \pm 10\text{ V}$	25,000			V/V
Output Voltage Swing	$R_L \geq 10\text{ k}\Omega$	± 12	± 14		V
	$R_L \geq 2\text{ k}\Omega$	± 10	± 13		V
Input Offset Voltage	$R_S \leq 100\text{ k}\Omega$		15	30	mV
Input Offset Current	$T_A = -55^\circ C$		30		pA
	$T_A = +85^\circ C$		185		pA
Input Current (either input)	$T_A = -55^\circ C$			200	pA
	$T_A = +85^\circ C$		2.5	4.0	nA

VOLTAGE OFFSET NULL CIRCUIT

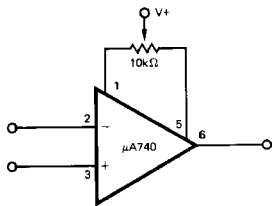

TRANSIENT RESPONSE TEST CIRCUIT

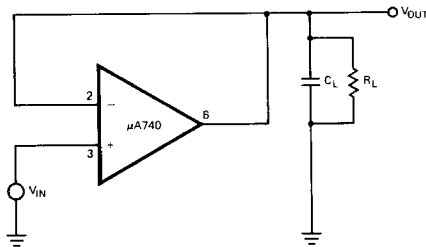

μ A740C

ELECTRICAL CHARACTERISTICS ($V_S = \pm 15V$, $T_C = 25^\circ C$ unless otherwise specified)

PARAMETER	CONDITIONS	MIN	TYP	MAX	UNITS
Input Offset Voltage	$R_S \leq 100k\Omega$		30	110	mV
Input Offset Current (Note 4)			60	300	pA
Input Current (either input) [Note 4]			0.1	2.0	nA
Input Resistance			1,000,000		M Ω
Large Signal Voltage Gain	$R_L \geq 2k\Omega$, $V_{OUT} = \pm 10V$	20,000	1,000,000		V/V
Output Resistance			75		Ω
Output Short Circuit Current			20		mA
Supply Current			4.2	8.0	mA
Power Consumption			126	240	mW
Slew Rate			6.0		V/ μ s
Unity Gain Bandwidth			1.0		MHz
Transient Response (Unity Gain)	Rise Time	$C_L \leq 100pF$, $R_L = 2k\Omega$, $V_{IN} = 100mV$	300		ns
	Overshoot		10		%

The following specifications apply for $0^\circ C \leq T_A \leq +70^\circ C$:

Input Voltage Range		± 10	± 12		V
Common Mode Rejection Ratio		55	80		dB
Supply Voltage Rejection Ratio			70	500	μ V/V
Large Signal Voltage Gain	$R_L \geq 2k\Omega$, $V_{OUT} = \pm 10V$		500,000		V/V
Output Voltage Swing	$R_L \geq 10k\Omega$	± 12	± 14		V
	$R_L \geq 2k\Omega$	± 10	± 13		V
Input Offset Voltage			30		mV
Input Offset Current			60		pA
Input Current (either input)			1.1	10	nA

NOTES:

1. Rating applies for ambient temperature to $+70^\circ C$; derate linearly at 6.3mW/ $^\circ C$ for ambient temperatures above $+70^\circ C$.
2. For supply voltages less than $\pm 15V$, the absolute maximum input voltage is equal to the supply voltage.
3. Short circuit may be to ground or either supply. Rating applies to $+125^\circ C$ case temperature or $+75^\circ C$ ambient temperature.
4. Typically doubles for every $10^\circ C$ increase in ambient temperature.

TYPICAL PERFORMANCE CURVES FOR μ A740 AND μ A740C

INPUT BIAS CURRENT AS A FUNCTION OF AMBIENT TEMPERATURE

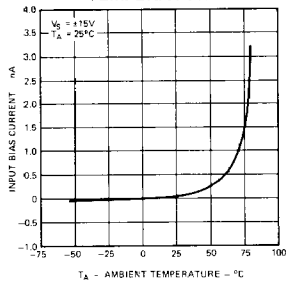

OPEN LOOP VOLTAGE GAIN AS A FUNCTION OF FREQUENCY

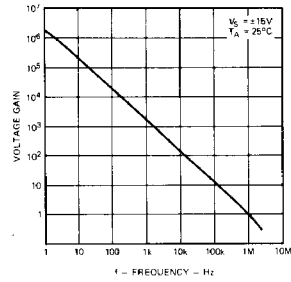

OUTPUT VOLTAGE SWING AS A FUNCTION OF FREQUENCY

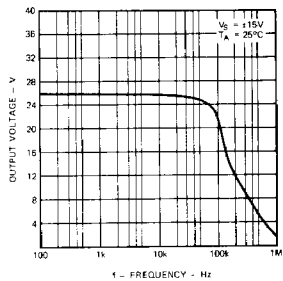

INPUT NOISE VOLTAGE AS A FUNCTION OF FREQUENCY

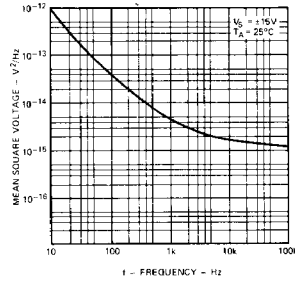

VOLTAGE FOLLOWER LARGE SIGNAL PULSE RESPONSE

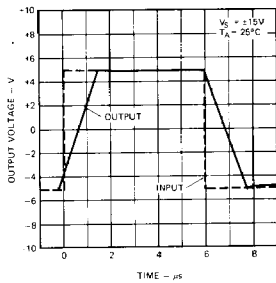

OPEN LOOP PHASE RESPONSE AS A FUNCTION OF FREQUENCY

