

Power Booster Amplifier

FEATURES

- WIDE SUPPLY RANGE – $\pm 15V$ to $\pm 150V$
- HIGH OUTPUT CURRENT –
1.5A Continuous (PB51),
2.0A Continuous (PB51A)
- VOLTAGE AND CURRENT GAIN
- HIGH SLEW –
50V/ μs Minimum (PB51)
75V/ μs Minimum (PB51A)
- PROGRAMMABLE OUTPUT CURRENT LIMIT
- HIGH POWER BANDWIDTH – 320 kHz Minimum
- LOW QUIESCENT CURRENT – 12mA Typical
- EVALUATION KIT – EK29

APPLICATIONS

- HIGH VOLTAGE INSTRUMENTATION
- ELECTROSTATIC TRANSDUCERS & DEFLECTION
- PROGRAMMABLE POWER SUPPLIES UP TO 280V P-P

DESCRIPTION

The PB51 is a high voltage, high current amplifier designed to provide voltage and current gain for a small signal, general purpose op amp. Including the power booster within the feedback loop of the driver amplifier results in a composite amplifier with the accuracy of the driver and the extended output voltage range and current capability of the booster. The PB51 can also be used without a driver in some applications, requiring only an external current limit resistor to function properly.

The output stage utilizes complementary MOSFETs, providing symmetrical output impedance and eliminating second breakdown limitations imposed by Bipolar Transistors. Internal feedback and gainset resistors are provided for a pin-strapable gain of 3. Additional gain can be achieved with a single external resistor. Compensation is not required for most driver/gain configurations, but can be accomplished with a single external capacitor. Enormous flexibility is provided through the choice of driver amplifier, current limit, supply voltage, voltage gain, and compensation.

This hybrid circuit utilizes a beryllia (BeO) substrate, thick film resistors, ceramic capacitors and semiconductor chips to maximize reliability, minimize size and give top performance. Ultrasonically bonded aluminum wires provide reliable interconnections at all operating temperatures. The 12-pin Power SIP package is electrically isolated.

EQUIVALENT SCHEMATIC

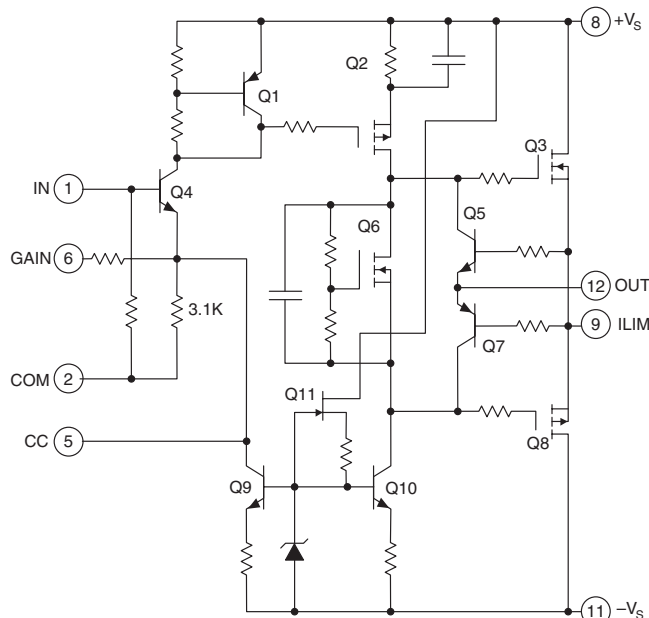

1. CHARACTERISTICS AND SPECIFICATIONS

ABSOLUTE MAXIMUM RATINGS

Parameter	Symbol	Min	Max	Units
SUPPLY VOLTAGE, $+V_S$ to $-V_S$			300	V
OUTPUT CURRENT, within SOA			2.0	A
POWER DISSIPATION, internal at $T_C = 25^\circ\text{C}$ (Note 1)			83	W
INPUT VOLTAGE, referred to COM		-15	15	V
TEMPERATURE, pin solder-10s max.			260	$^\circ\text{C}$
TEMPERATURE, junction (Note 1)			175	$^\circ\text{C}$
TEMPERATURE RANGE, storage		-55	125	$^\circ\text{C}$
OPERATING TEMPERATURE RANGE, case		-25	85	$^\circ\text{C}$

SPECIFICATIONS (PER AMPLIFIER)

PARAMETER	TEST CONDITIONS (Note 2)	PB51			PB51A			UNITS
		MIN	TYP	MAX	MIN	TYP	MAX	
INPUT								
OFFSET VOLTAGE, initial			± 0.75	± 1.75		*	± 1.0	V
OFFSET VOLTAGE, vs. temperature	Full temperature range (Note 3)		-4.5	-7		*	*	mV/ $^\circ\text{C}$
INPUT IMPEDANCE, DC		25	50		*	*		k
INPUT CAPACITANCE			3			*		pF
CLOSED LOOP GAIN RANGE		3	10	25	*	*	*	V/V
GAIN ACCURACY, internal R_g , R_f	$A_V = 3$		± 10	± 15		*	*	%
GAIN ACCURACY, external R_f	$A_V = 10$		± 15	± 25		*	*	%
PHASE SHIFT	$f = 10\text{kHz}$, $A_{VCL} = 10$, $C_C = 22\text{pF}$		10			*		$^\circ$
	$f = 200\text{kHz}$, $A_{VCL} = 10$, $C_C = 22\text{pF}$		60			*		$^\circ$
OUTPUT								
VOLTAGE SWING	$I_O = 1.5\text{A}$ (PB58), 2A (PB58A)	$V_S - 11$	$V_S - 8$		$V_S - 15$	$V_S - 11$		V
VOLTAGE SWING	$I_O = 1\text{A}$	$V_S - 10$	$V_S - 7$		*	*		V
VOLTAGE SWING	$I_O = 0.1\text{A}$	$V_S - 8$	$V_S - 5$		*	*		V
CURRENT, continuous		1.5			2.0			A
SLEW RATE	Full temperature range	50	100		75	*		V/ μs
CAPACITIVE LOAD	Full temperature range		2200			*		pF
SETTLING TIME to .1%	$R_L = 100$, 2V step		2			*		μs
POWER BANDWIDTH	$V_C = 100 V_{P-P}$	160	230		240	*		kHz
SMALL SIGNAL BANDWIDTH	$C_C = 22\text{pF}$, $A_V = 25$, $V_{CC} = \pm 100$		100			*		kHz
SMALL SIGNAL BANDWIDTH	$C_C = 22\text{pF}$, $A_V = 3$, $V_{CC} = \pm 30$		1			*		MHz

PARAMETER	TEST CONDITIONS (Note 2)	PB51			PB51A			UNITS
		MIN	TYP	MAX	MIN	TYP	MAX	
POWER SUPPLY								
VOLTAGE, $\pm V_s$ (Note 4)	Full temperature range	± 15 (Note 6)	± 60	± 150	*	*	*	V
CURRENT, quiescent	$V_s = \pm 15$		11			*		mA
	$V_s = \pm 60$		12			*		mA
	$V_s = \pm 150$		14	18		*	*	mA
THERMAL								
RESISTANCE, AC junction to case (Note 5)	Full temp. range, $f > 60\text{Hz}$		1.2	1.3		*	*	$^{\circ}\text{C/W}$
RESISTANCE, DC junction to case	Full temp. range, $f < 60\text{Hz}$		1.6	1.8		*	*	$^{\circ}\text{C/W}$
RESISTANCE, junction to air	Full temperature range		30			*		$^{\circ}\text{C/W}$
TEMPERATURE RANGE, case	Meets full range specifications	-25	25	85	*	*	*	$^{\circ}\text{C}$

- NOTES: *
- The specification of PB51A is identical to the specification for PB51 in applicable column to the left.
 - Long term operation at the maximum junction temperature will result in reduced product life. Derate internal power dissipation to achieve high MTTF (Mean Time to Failure).
 - The power supply voltage specified under typical (TYP) applies, $T_c = 25^{\circ}\text{C}$ unless otherwise noted.
 - Guaranteed by design but not tested.
 - $+V_s$ and $-V_s$ denote the positive and negative supply rail respectively.
 - Rating applies if the output current alternates between both output transistors at a rate faster than 60Hz.
 - $+V_s/-V_s$ must be at least 15V above/below COM.

CAUTION The PB51 is constructed from MOSFET transistors. ESD handling procedures must be observed. The internal substrate contains beryllia (BeO). Do not break the seal. If accidentally broken, do not crush, machine, or subject to temperatures in excess of 850°C to avoid generating toxic fumes.

EXTERNAL CONNECTIONS

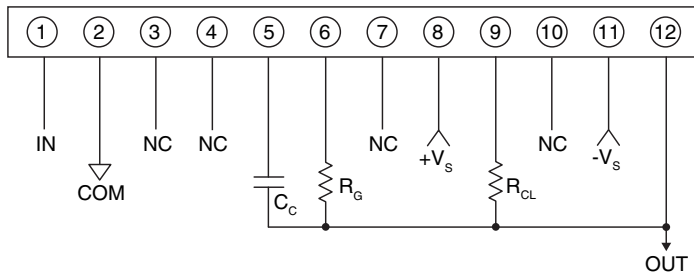

TYPICAL APPLICATION

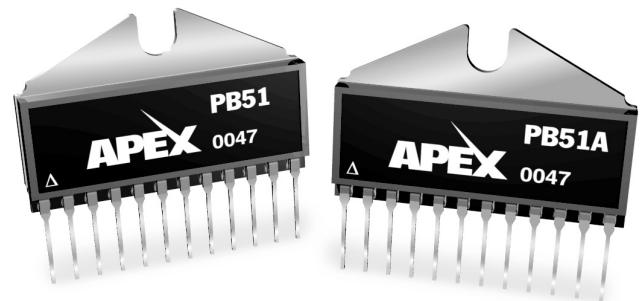
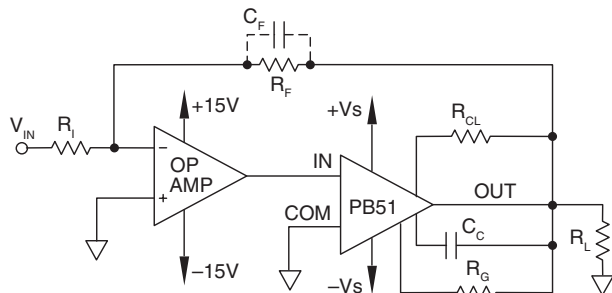

12-pin SIP PACKAGE STYLE DP
Formed leads available. See package styles ED & EE

2. TYPICAL PERFORMANCE GRAPHS

POWER DERATING

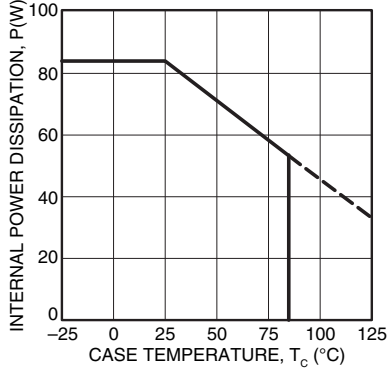

CURRENT LIMIT

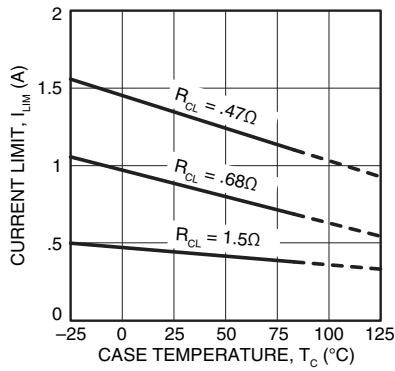

OUTPUT VOLTAGE SWING

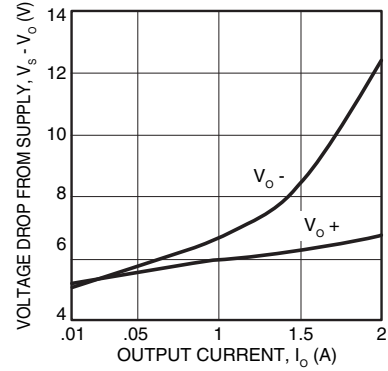

SMALL SIGNAL RESPONSE

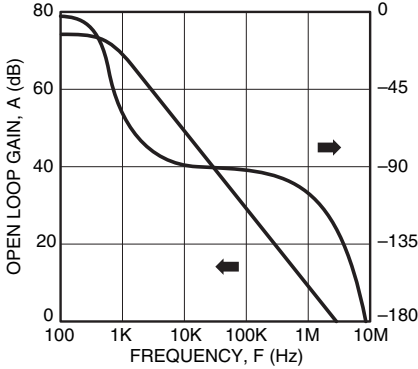

SMALL SIGNAL RESPONSE

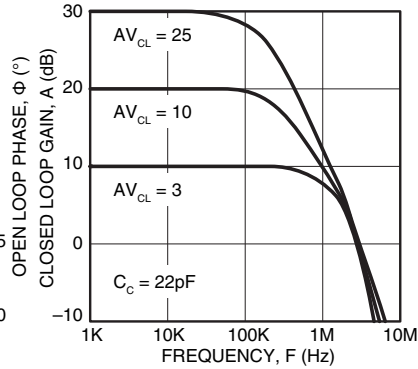

SMALL SIGNAL RESPONSE

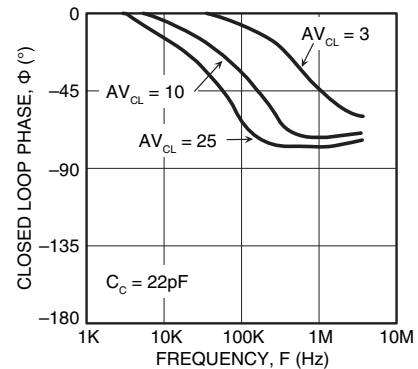

QUIESCENT CURRENT

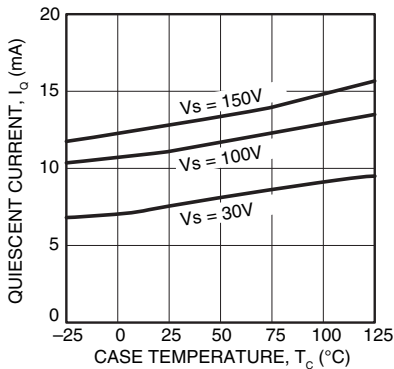

INPUT OFFSET VOLTAGE

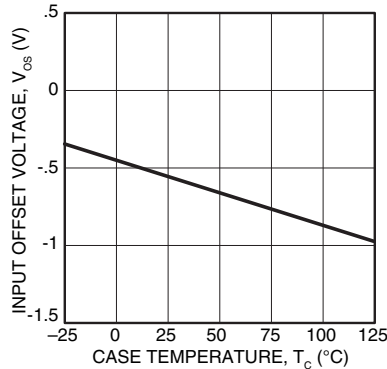

SLEW RATE VS. TEMP.

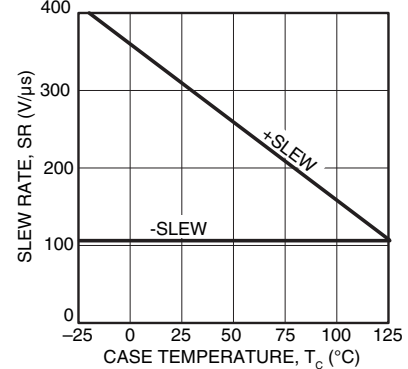

POWER RESPONSE

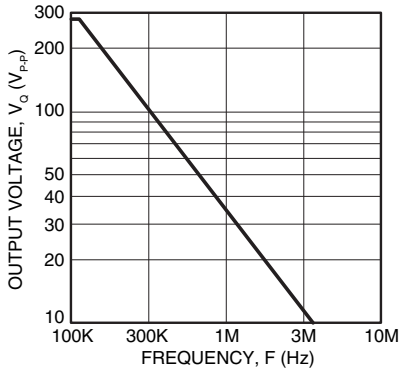

PULSE RESPONSE

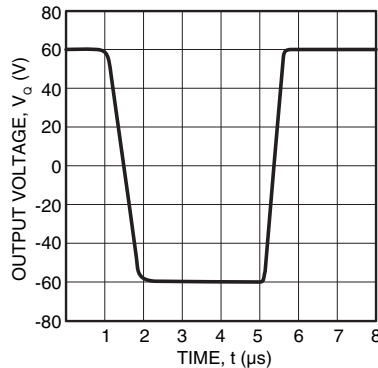

HARMONIC DISTORTION

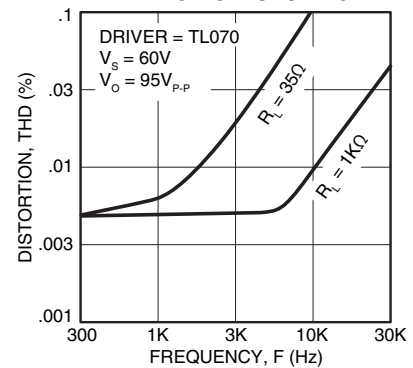

GENERAL

Please read Application Note 1 "General Operating Considerations" which covers stability, supplies, heat sinking, mounting, current limit, SOA interpretation, and specification interpretation. Visit www.Cirrus.com for design tools that help automate tasks such as calculations for stability, internal power dissipation, current limit; heat sink selection; Apex Precision Power's complete Application Notes library; Technical Seminar Workbook; and Evaluation Kits.

CURRENT LIMIT

For proper operation, the current limit resistor (R_{CL}) must be connected as shown in the external connection diagram. The minimum value is 0.33 with a maximum practical value of 47. For optimum reliability the resistor value should be set as high as possible. The value is calculated as follows:

$$+I_L = .65/R_{CL} + .010, -I_L = .65/R_{CL}$$

SAFE OPERATING AREA

NOTE: The output stage is protected against transient flyback. However, for protection against sustained, high energy flyback, external fast-recovery diodes should be used.

COMPOSITE AMPLIFIER CONSIDERATIONS

Cascading two amplifiers within a feedback loop has many advantages, but also requires careful consideration of several amplifier and system parameters. The most important of these are gain, stability, slew rate, and output swing of the driver. Operating the booster amplifier in higher gains results in a higher slew rate and lower output swing requirement for the driver, but makes stability more difficult to achieve.

GAIN SET

The booster's closed-loop gain is given by the equation below. The composite amplifier's closed loop gain is determined by the feedback network, that is: $-R_f/R_i$ (inverting) or $1+R_f/R_i$ (non-inverting). The driver amplifier's "effective gain" is equal to the composite gain divided by the booster gain.

$$R_G = [(A_v - 1) \cdot 3.1K] - 6.2K$$

$$A_v = \frac{R_G + 6.2K}{3.1K} + 1$$

Example: Inverting configuration (figure 1) with

$$R_i = 2K, R_f = 60K, R_g = 0 :$$

$$A_v (\text{booster}) = (6.2K/3.1K) + 1 = 3$$

$$A_v (\text{composite}) = 60K/2K = -30$$

$$A_v (\text{driver}) = -30/3 = -10$$

STABILITY

Stability can be maximized by observing the following guidelines:

1. Operate the booster in the lowest practical gain.
2. Operate the driver amplifier in the highest practical effective gain.
3. Keep gain-bandwidth product of the driver lower than the closed loop bandwidth of the booster.
4. Minimize phase shift within the loop.

A good compromise for (1) and (2) is to set booster gain from 3 to 10 with total (composite) gain at least a factor of 3 times booster gain. Guideline (3) implies compensating the driver as required in low composite gain configurations. Phase shift within the loop (4) is minimized through use of booster and loop compensation capacitors C_c and C_f when required. Typical values are 5pF to 33pF.

Stability is the most difficult to achieve in a configuration where driver effective gain is unity (ie; total gain = booster gain). For this situation, Table 1 gives compensation values for optimum square wave response with the op amp drivers listed.

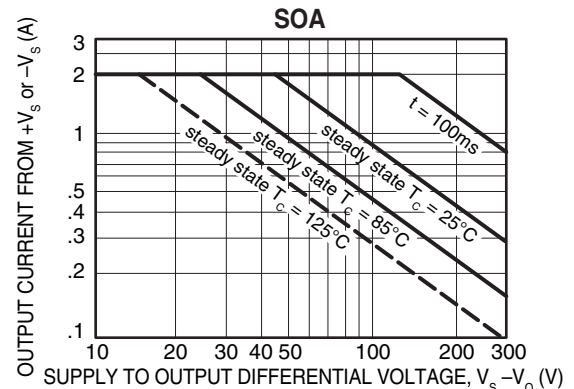

DRIVER	C_{CH}	C_F	C_C	FPBW	SR
OP07	-	22p	22p	4kHz	1.5
741	-	18p	10p	20kHz	7
LF155	-	4.7p	10p	60kHz	>60
LF156	-	4.7p	10p	80kHz	>60
TL070	22p	15p	10p	80kHz	>60

For: $R_F = 33K$, $R_I = 3.3K$, $R_G = 22K$

TABLE 1. TYPICAL VALUES FOR CASE WHERE OP AMP EFFECTIVE GAIN = 1.

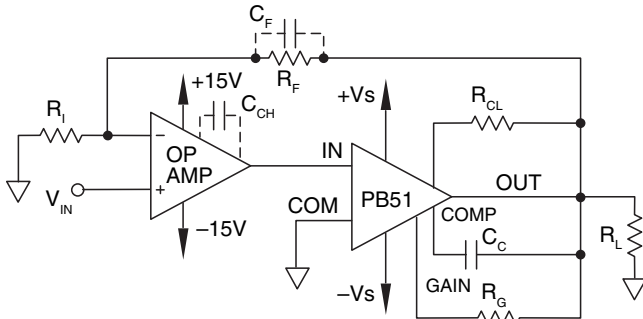

SLEW RATE

The slew rate of the composite amplifier is equal to the slew rate of the driver times the booster gain, with a maximum value equal to the booster slew rate.

OUTPUT SWING

The maximum output voltage swing required from the driver op amp is equal to the maximum output swing from the booster divided by the booster gain. The V_{os} of the booster must also be supplied by the driver, and should be subtracted from the available swing range of the driver. Note also that effects of V_{os} drift and booster gain accuracy should be considered when calculating maximum available driver swing.

CONTACTING CIRRUS LOGIC SUPPORT

For all Apex Precision Power product questions and inquiries, call toll free 800-546-2739 in North America.

For inquiries via email, please contact apex.support@cirrus.com.

International customers can also request support by contacting their local Cirrus Logic Sales Representative.

To find the one nearest to you, go to www.cirrus.com

IMPORTANT NOTICE

Cirrus Logic, Inc. and its subsidiaries ("Cirrus") believe that the information contained in this document is accurate and reliable. However, the information is subject to change without notice and is provided "AS IS" without warranty of any kind (express or implied). Customers are advised to obtain the latest version of relevant information to verify, before placing orders, that information being relied on is current and complete. All products are sold subject to the terms and conditions of sale supplied at the time of order acknowledgment, including those pertaining to warranty, indemnification, and limitation of liability. No responsibility is assumed by Cirrus for the use of this information, including use of this information as the basis for manufacture or sale of any items, or for infringement of patents or other rights of third parties. This document is the property of Cirrus and by furnishing this information, Cirrus grants no license, express or implied under any patents, mask work rights, copyrights, trademarks, trade secrets or other intellectual property rights. Cirrus owns the copyrights associated with the information contained herein and gives consent for copies to be made of the information only for use within your organization with respect to Cirrus integrated circuits or other products of Cirrus. This consent does not extend to other copying such as copying for general distribution, advertising or promotional purposes, or for creating any work for resale.

CERTAIN APPLICATIONS USING SEMICONDUCTOR PRODUCTS MAY INVOLVE POTENTIAL RISKS OF DEATH, PERSONAL INJURY, OR SEVERE PROPERTY OR ENVIRONMENTAL DAMAGE ("CRITICAL APPLICATIONS"). CIRRUS PRODUCTS ARE NOT DESIGNED, AUTHORIZED OR WARRANTED TO BE SUITABLE FOR USE IN PRODUCTS SURGICALLY IMPLANTED INTO THE BODY, AUTOMOTIVE SAFETY OR SECURITY DEVICES, LIFE SUPPORT PRODUCTS OR OTHER CRITICAL APPLICATIONS. INCLUSION OF CIRRUS PRODUCTS IN SUCH APPLICATIONS IS UNDERSTOOD TO BE FULLY AT THE CUSTOMER'S RISK AND CIRRUS DISCLAIMS AND MAKES NO WARRANTY, EXPRESS, STATUTORY OR IMPLIED, INCLUDING THE IMPLIED WARRANTIES OF MERCHANTABILITY AND FITNESS FOR PARTICULAR PURPOSE, WITH REGARD TO ANY CIRRUS PRODUCT THAT IS USED IN SUCH A MANNER. IF THE CUSTOMER OR CUSTOMER'S CUSTOMER USES OR PERMITS THE USE OF CIRRUS PRODUCTS IN CRITICAL APPLICATIONS, CUSTOMER AGREES, BY SUCH USE, TO FULLY INDEMNIFY CIRRUS, ITS OFFICERS, DIRECTORS, EMPLOYEES, DISTRIBUTORS AND OTHER AGENTS FROM ANY AND ALL LIABILITY, INCLUDING ATTORNEYS' FEES AND COSTS, THAT MAY RESULT FROM OR ARISE IN CONNECTION WITH THESE USES.

Cirrus Logic, Cirrus, and the Cirrus Logic logo designs, Apex Precision Power, Apex and the Apex Precision Power logo designs are trademarks of Cirrus Logic, Inc. All other brand and product names in this document may be trademarks or service marks of their respective owners.