

**Features**

- Slew rate—1500 V/ $\mu$ s
- Output drive—100 mA
- Rise and fall times—2.9 ns
- Input resistance— $10^{11}\Omega$
- Power bandwidth—100 MHz
- MIL-STD-883 devices 100% manufactured in U.S.A.

**Advantages**

- Excellent phase linearity
- Driver cables and other capacitive loads
- Wide supply range, single or split

**Ordering Information**

Part No.	Temp. Range	Package Outline #
ELH0033G/883B	-55°C to +125°C	TO-8 MDP0002

8001401ZX is the SMD version of this device.

**Connection Diagram**

12-Pin TO-8

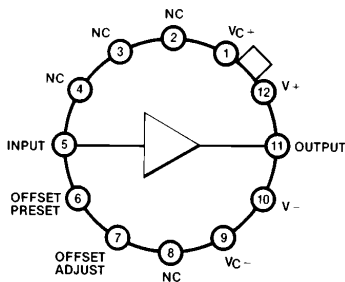

Top View

Note: Case is electrically isolated.

0033-1

**General Description**

The ELH0033 is a high-speed, FET input voltage follower buffer designed to provide high output currents from DC to over 100 MHz. The ELH0033 slews at 1500 V/ $\mu$ s and will drive 100 $\Omega$  loads. Phase linearity is excellent to 20 MHz, allowing the buffer to be included in op amp loops.

The ELH0033 is intended to fulfill a wide range of buffer applications such as high-speed line drivers, video impedance transformation, nuclear instrumentation amplifiers, op amp isolation buffers for driving reactive loads and high impedance input buffers for high-speed A to D's and comparators.

These devices are constructed using specially selected junction FETs and active laser trimming to achieve guaranteed performance specifications. The ELH0033 is specified for operation from -55°C to +125°C.

Elantec facilities comply with MIL-I-45208A and other applicable quality specifications. Elantec's Military devices are 100% fabricated and assembled in our rigidly controlled, ultra-clean facilities in Milpitas, California. For additional information on Elantec's Quality and Reliability Assurance policy and procedures request brochure QRA-1.

**Equivalent Schematic**

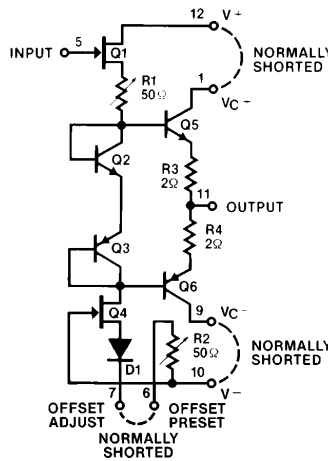

0033-2

Note: All information contained in this data sheet has been carefully checked and is believed to be accurate as of the date of publication; however, this data sheet cannot be a "controlled document". Current revisions, if any, to these specifications are maintained at the factory and are available upon your request. We recommend checking the revision level before finalization of your design documentation. Patent pending.

# ELH0033G/883/8001401ZX

## Fast Buffer Amplifier

### Absolute Maximum Ratings

V <sub>S</sub>	Supply Voltage (V <sup>+</sup> - V <sup>-</sup> )	40V	T <sub>A</sub>	Operating Temperature Range	
V <sub>IN</sub>	Input Voltage	40V		ELH0033	-55°C to +125°C
P <sub>D</sub>	Power Dissipation (See Curves)	1.5W	T <sub>J</sub>	Operating Junction Temperature	175°C
I <sub>OC</sub>	Continuous Output Current	±100 mA	T <sub>ST</sub>	Storage Temperature	-65°C to +150°C
I <sub>OP</sub>	Peak Output Current	±250 mA		Lead Temperature	
				(Soldering, 10 seconds)	300°C

#### Important Note:

All parameters having Min/Max specifications are guaranteed. The Test Level column indicates the specific device testing actually performed during production and Quality inspection. Elantec performs most electrical tests using modern high-speed automatic test equipment, specifically the LTX77 Series system. Unless otherwise noted, all tests are pulsed tests, therefore T<sub>J</sub> = T<sub>C</sub> = T<sub>A</sub>.

Test Level	Test Procedure
I	100% production tested and QA sample tested per QA test plan QCX0002.
II	100% production tested at T <sub>A</sub> = 25°C and QA sample tested at T <sub>A</sub> = 25°C, T <sub>MAX</sub> and T <sub>MIN</sub> per QA test plan QCX0002.
III	QA sample tested per QA test plan QCX0002.
IV	Parameter is guaranteed (but not tested) by Design and Characterization Data.
V	Parameter is typical value at T <sub>A</sub> = 25°C for information purposes only.

### DC Electrical Characteristics V<sub>S</sub> = ±15V, V<sub>IN</sub> = 0V, T<sub>MIN</sub> ≤ T<sub>A</sub> ≤ T<sub>MAX</sub>

Parameter	Description	Test Conditions	ELH0033				Units
			Min	Typ	Max	Test Level	
V <sub>OS</sub>	Output Offset Voltage	R <sub>S</sub> ≤ 100 kΩ, T <sub>J</sub> = 25°C (Note 1)		5	10	I	mV
		R <sub>S</sub> ≤ 100 kΩ			15	I	mV
ΔV <sub>OS</sub> /ΔT	Average Temperature Coefficient of Offset Voltage	R <sub>S</sub> = 100Ω		50		V	μV/°C
I <sub>B</sub>	Input Bias Current	T <sub>J</sub> = 25°C (Note 1)			250	I	pA
		T <sub>A</sub> = 25°C (Note 2)			2.5	IV	nA
		T <sub>J</sub> = T <sub>A</sub> = T <sub>MAX</sub>			10	I	nA
A <sub>V</sub>	Voltage Gain	R <sub>S</sub> = 100Ω, R <sub>L</sub> = 1 kΩ, V <sub>IN</sub> = ±10V	0.97	0.98	1.00	I	V/V
R <sub>IN</sub>	Input Impedance	R <sub>L</sub> = 1 kΩ	10 <sup>10</sup>	10 <sup>11</sup>		IV	Ω
		T <sub>J</sub> = 25°C (Note 1), R <sub>L</sub> = 1 kΩ	10 <sup>10</sup>	10 <sup>11</sup>		I	Ω
R <sub>O</sub>	Output Impedance	R <sub>L</sub> = 1 kΩ, V <sub>IN</sub> = ±1V		6	10	I	Ω
V <sub>O</sub>	Output Voltage Swing	V <sub>IN</sub> = ±14V, R <sub>L</sub> = 1 kΩ	±12			I	V
		V <sub>IN</sub> = ±10.5V, R <sub>L</sub> = 100Ω, T <sub>A</sub> = 25°C	±9			I	V
I <sub>S</sub>	Supply Current		14.5	20	22	I	mA
	Power Consumption			600	660	I	mW

Note 1: Specification is at 25°C junction temperature due to requirements of high-speed automatic testing. Actual values at operating temperature will exceed the value at T<sub>J</sub> = 25°C. When supply voltages are ±15V, no-load operating junction temperature may rise 40°C–60°C above ambient and more under load conditions. Accordingly, V<sub>OS</sub> may change one to several mV, and I<sub>B</sub> will change significantly during warm-up. Refer to I<sub>B</sub> vs temperature graph for expected values.

Note 2: Measured in still air 7 minutes after application of power.

# ELH0033G/883/8001401ZX

## Fast Buffer Amplifier

### AC Electrical Characteristics $T_C = 25^\circ\text{C}$ , $V_S = \pm 15\text{V}$ , $R_S = 50\Omega$ , $R_L = 1\text{k}\Omega$

Parameter	Description	Test Conditions	ELH0033				Units
			Min	Typ	Max	Test Level	
SR	Slew Rate	$V_{IN} = \pm 10\text{V}$	1000	1500		III	$\text{V}/\mu\text{s}$
BW	Bandwidth	$V_{IN} = 1\text{V}_{\text{rms}}$		100		V	MHz
	Phase Non-Linearity	$\text{BW} = 1\text{MHz to } 20\text{MHz}$		2		V	$^\circ$
$t_r$	Rise Time	$\Delta V_{IN} = 0.5\text{V}$		2.9		V	ns
$t_p$	Propagation Delay	$\Delta V_{IN} = 0.5\text{V}$		1.2		V	ns
HD	Harmonic Distortion	$f > 1\text{kHz}$		<0.1		V	%
$A_v$	Voltage Gain	$R_S = 100\Omega$ , $V_{IN} = 1\text{V}_{\text{rms}}$ , $f = 1\text{kHz}$	0.97	0.98	1.00	I	V/V
$R_O$	Output Impedance	$V_{IN} = 1\text{V}_{\text{rms}}$ , $f = 1\text{kHz}$		6	10	I	$\Omega$

### Typical Performance Curves

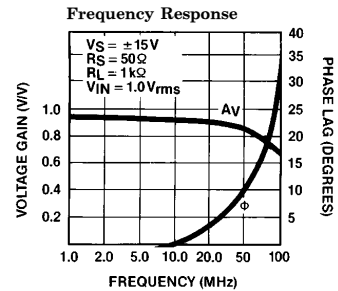
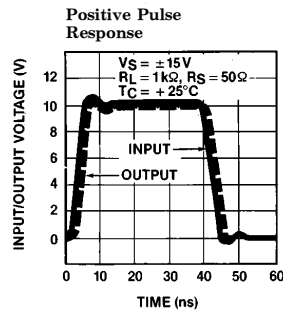
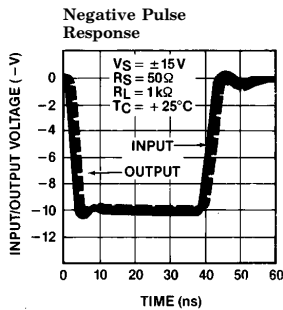
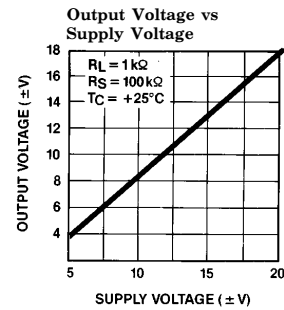
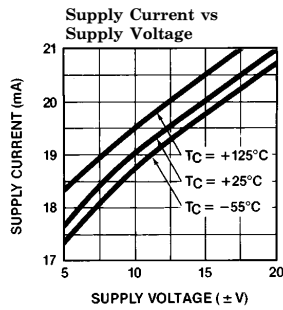
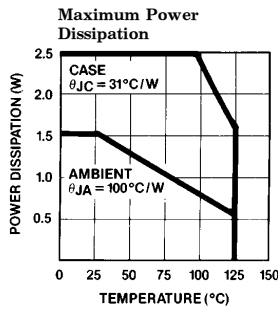

0033-3

# ELH0033G/883/8001401ZX

## Fast Buffer Amplifier

### Typical Performance Curves — Contd.

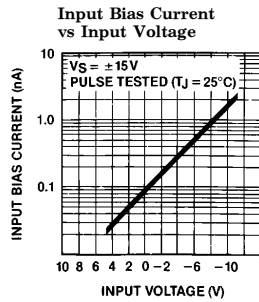
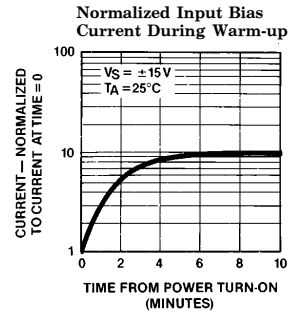
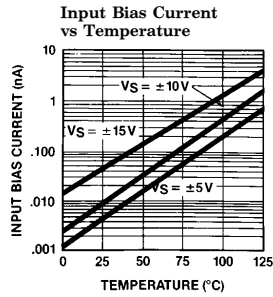
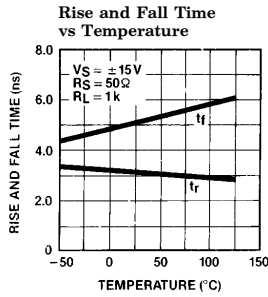

0033-4

### Typical Applications

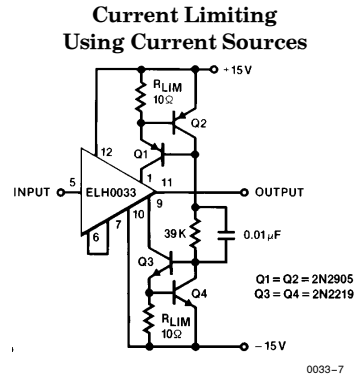
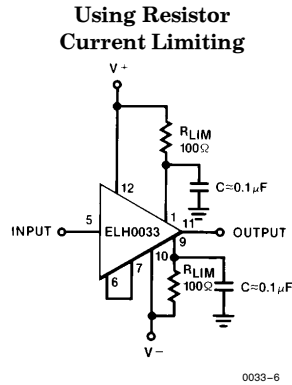
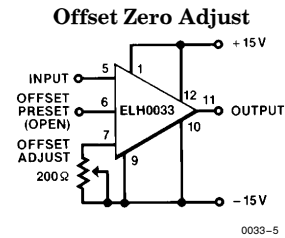

# ELH0033G/883/8001401ZX

## Fast Buffer Amplifier

### Typical Applications — Contd.

**High Input Impedance AC Coupled Amplifier**

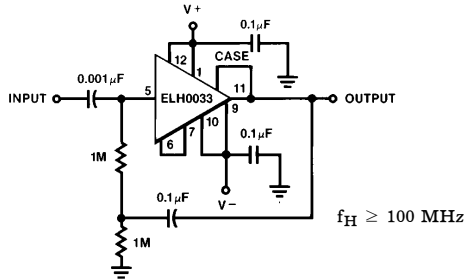

0033-8

**Coaxial Cable Driver**

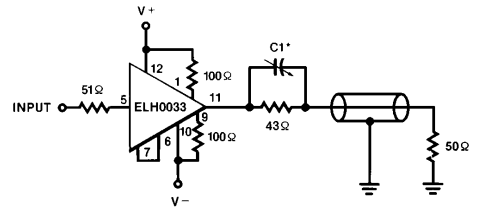

0033-9

\*Select C1 for optimum pulse response

**Instrumentation Shield/Line Driver**

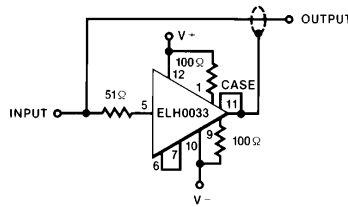

0033-10

**Single Supply AC Amplifier**

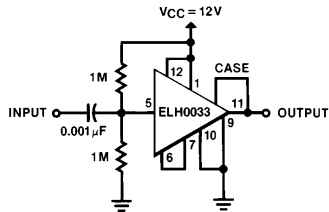

0033-11

**4.5 MHz Notch Filter**

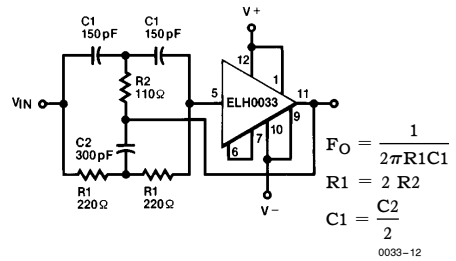

0033-12

**High-Speed Sample and Hold**

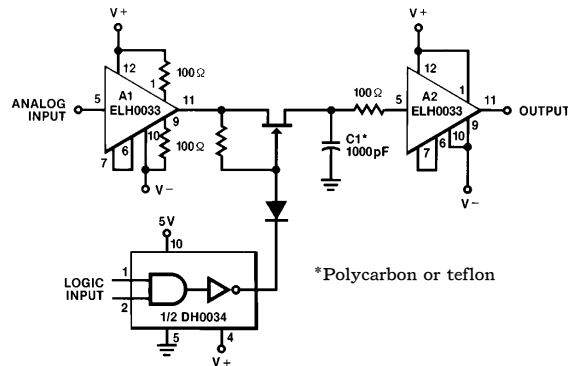

0033-13

# ELH0033G/883/8001401ZX

## Fast Buffer Amplifier

### Applications Information

#### Recommended Layout Precautions

RF/video printed circuit board layout rules should be followed when using the ELH0033 since it will provide power gain to frequencies over 100 MHz. Ground planes are recommended and power supplies should be decoupled at each device with low inductance capacitors. In addition, ground plane shielding may be extended to the metal case of the device since it is electrically isolated from internal circuitry. Alternatively, the case should be connected to the output to minimize input capacitance.

#### Offset Voltage Adjustment

The ELH0033's offset voltages have been actively trimmed by laser to meet guaranteed specifications when the offset preset pin is shorted to the offset adjust pin. The pre-calibration allows the devices to be used in most DC or AC applications without individually offset nulling each device. If offset null is desirable, it is simply obtained by leaving the offset preset pin open and connecting a trim pot of 100Ω between the offset adjust pin and V<sup>-</sup>.

#### Operation from Single or Asymmetrical Power Supplies

This device type may be readily used in applications where symmetrical supplies are unavailable or not desirable. A typical application might be an interface to a MOS shift register where V<sup>+</sup> = +5V and V<sup>-</sup> = -12V. In this case, an apparent output offset occurs due to the device's voltage gain of less than unity. This additional output offset error may be predicted by:

$$\Delta V_O \cong (1 - A_V) \frac{(V^+ - V^-)}{2} = 0.005 (V^+ - V^-)$$

where: A<sub>V</sub> = No load voltage gain, typically 0.99  
V<sup>+</sup> = Positive supply voltage  
V<sup>-</sup> = Negative supply voltage

For the above example, ΔV<sub>O</sub> would be -35 mV. This may be adjusted to zero as described in Section 2. For AC coupled applications, no additional offset occurs if the DC input is properly biased as illustrated in the "typical applications" section.

#### Short Circuit Protection

In order to optimize transient response and output swing, output current limit has been omitted from the ELH0033. Short circuit protection may be added by inserting appropriate value resistors between V<sup>+</sup> and V<sub>C</sub><sup>+</sup> pins and V<sup>-</sup> and V<sub>C</sub><sup>-</sup> pins. Resistor values may be predicted by:

$$R_{LIM} \cong \frac{V^+}{I_{SC}} = \frac{V^-}{I_{SC}}$$

where: I<sub>SC</sub> ≤ 100 mA for ELH0033

The inclusion of limiting resistors in the collectors of the output transistors reduces output voltage swing. Decoupling V<sub>C</sub><sup>+</sup> and V<sub>C</sub><sup>-</sup> pins with capacitors to ground will retain full output swing for transient pulses. An alternate active current limit technique that retains full DC output swing uses current sources which are saturated during normal operation thus applying full supply voltage to the V<sub>C</sub> pins. Under fault conditions, the voltage decreases as required by the overload.

$$R_{LIM} \cong \frac{V_{BE}}{I_{SC}} = \frac{0.6V}{60 \text{ mA}} = 10\Omega$$

#### Capacitive Loading

The ELH0033 is designed to drive capacitive loads such as coaxial cables in excess of several thousand picofarads without susceptibility to oscillation. However, peak current resulting from (C × d<sub>v</sub>/d<sub>t</sub>) should be limited below absolute maximum peak current ratings for the devices.

Thus:

$$\frac{\Delta V_{IN}}{\Delta t} \times C_L \leq I_{OUT} \leq \pm 250 \text{ mA}$$

In addition, power dissipation resulting from driving capacitive loads plus standby power should be kept below the total package power rating:

$$P_{D \text{ pkg}} \geq P_{DC} + P_{AC}$$

$$P_{D \text{ pkg}} \geq (V^+ - V^-) \times I_S + P_{AC}$$

$$P_{AC} \cong (V_{P-P})^2 \times f \times C_L$$

# *ELH0033G/883/8001401ZX*

## *Fast Buffer Amplifier*

where:  $V_{P-P}$  = Peak-to-peak output voltage swing  
 $f$  = Frequency  
 $C_L$  = Load Capacitance

### Operation within an Op Amp Loop

Both devices may be used as a current booster or isolation buffer within a closed loop with op amps such as the ELH0032 and HA2500 and HA2600 series. An isolation resistor of  $47\Omega$  should be used between the op amp output and the input of ELH0033. The wide bandwidth and high slew rates of the ELH0033 assure that the loop has the characteristics of the op amp and that additional rolloff is not required.

### Burn-In Circuit

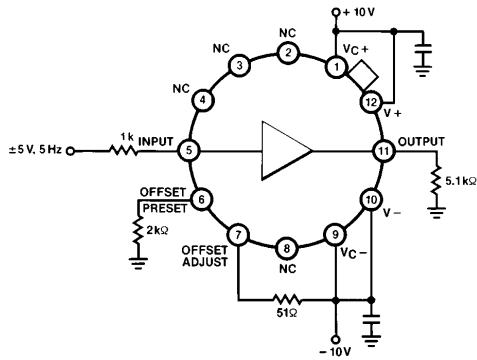

0033-14

### Hardware

In order to utilize the full drive capabilities of the ELH0033, it should be mounted with a heatsink, particularly for extended temperature operation. The case is isolated from the circuit and may be connected to system chassis.

### IMPORTANT!

Power supply bypassing is necessary to prevent oscillation with the ELH0033 in all circuits. Low inductance ceramic disc capacitors with the shortest practical lead lengths must be connected from each supply lead (within  $\frac{1}{4}$ " to  $\frac{1}{2}$ " of the device package) to a ground plane. Capacitors should be one or two  $0.1\mu F$  in parallel; adding a  $4.7\mu F$  solid tantalum capacitor will help in troublesome instances.

# ELH0033G/883/8001401ZX

## Fast Buffer Amplifier

### ELH0033 Macromodel

```

* Connections:   input
*               |      V+
*               |      |      Vc+
*               |      |      |      V-
*               |      |      |      |      Vc-
*               |      |      |      |      |      output
*               |      |      |      |      |
.subckt M0033   5      12     1      10     9      11
* Models
.model qn npn (is=5e-14 bf=150 vaf=100 re=1 rb=5 re=1 ikf=200mA
+cje=5pF cjc=5pF mje=.42 mjc=.23 tf=.3nS tr=200nS br=5 vtf=0)
.model qp pnp (is=5e-14 bf=150 vaf=100 rc=.2 rb=3 re=1 ikf=100mA
+cje=5.7pF cjc=4pF tf=.3nS mje=.32 mjc=.43 tr=170nS br=5 vtf=0)
.model qf njf (vto=-3V beta=4.0e-3 cgd=4pF cgs=10pF lambda=671.0e-6)
* Resistors
r1 20 21 58.33
r2 27 10 58.33
r3 22 11 2
r4 11 23 2
* Transistors
j1 12 5 20 qf
j4 24 10 26 qf
q2 21 21 25 qn
q3 24 24 25 qp
q5 1 21 22 qn
q6 9 24 23 qp
q7 26 26 27 qn
.ends

```



# ELH0033G/883/8001401ZX

Fast Buffer Amplifier

## ELH0033 Macromodel — Contd.

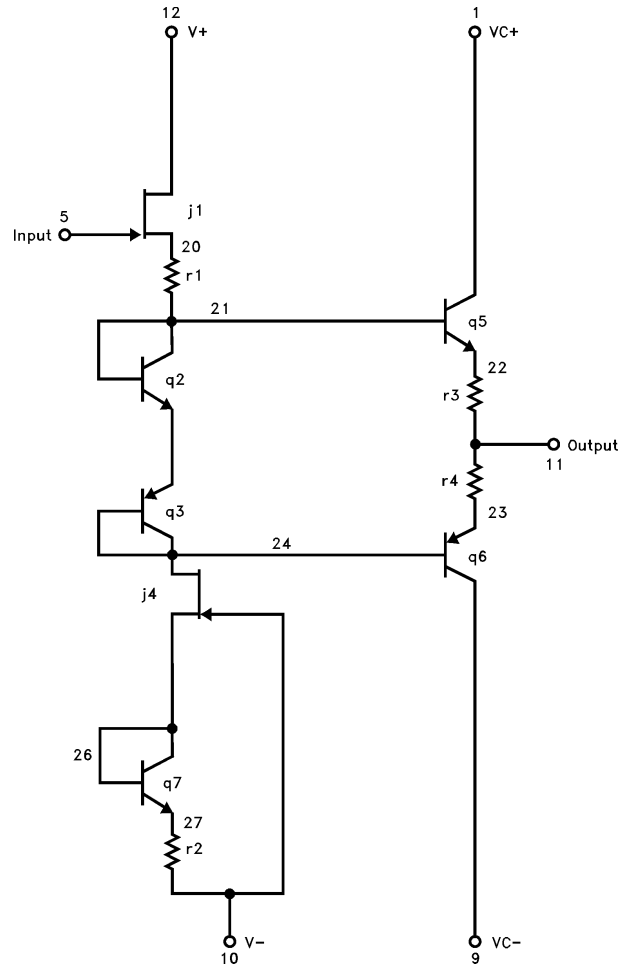

0033-16

**BLANK**

BLANK

# ***ELH0033G/883/8001401ZX***

## ***Fast Buffer Amplifier***

### **General Disclaimer**

Specifications contained in this data sheet are in effect as of the publication date shown. Elantec, Inc. reserves the right to make changes in the circuitry or specifications contained herein at any time without notice. Elantec, Inc. assumes no responsibility for the use of any circuits described herein and makes no representations that they are free from patent infringement.

***élantec***  
HIGH PERFORMANCE ANALOG INTEGRATED CIRCUITS

### **Elantec, Inc.**

1996 Tarob Court

Milpitas, CA 95035

Telephone: (408) 945-1323

(800) 333-6314

Fax: (408) 945-9305

European Office: 44-71-482-4596

### **WARNING — Life Support Policy**

Elantec, Inc. products are not authorized for and should not be used within Life Support Systems without the specific written consent of Elantec, Inc. Life Support systems are equipment intended to support or sustain life and whose failure to perform when properly used in accordance with instructions provided can be reasonably expected to result in significant personal injury or death. Users contemplating application of Elantec, Inc. products in Life Support Systems are requested to contact Elantec, Inc. factory headquarters to establish suitable terms & conditions for these applications. Elantec, Inc.'s warranty is limited to replacement of defective components and does not cover injury to persons or property or other consequential damages.