

AUDIO 1 CHIP TUNER SYSTEM

The DBL1091 is electronic tuner one chip IC for car stereo system and easily designed to smallize system. It is consists of AM Tuner, FM IF, MPX with HCC, SNC

FUNCTIONS

- AM : MIX, OSC, RF-AGC, ANT DAMPING AGC, IF AMP, IF BUFFER, DETECTOR, S-METER, TU-LED
- FM : IF AMP, QUADRATURE DET, AFC, S-METER, TU-LED, IF BUFFER, SOFT MUTE, BAND MUTE
- MPX : NO CONTROLLED VCO, HCC, SNC COMPULSION MONO, ST-LED

FEATURES

- Be reduce peripheral component
- No controlled VCO
- Small package (36SSOP)
- Band mute function is possible for Europe model.
- Reduced side stop at seek, scan.

APPLICATIONS

- The Car Stereo, General Audio System.

36SSOP

Unit: mm

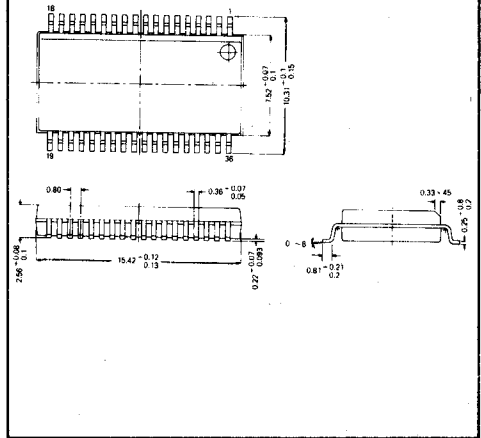

DBL 1091-V

MAXIMUM RATINGS(Ta=25°C)

Characteristics	Symbol	Rating	Unit
Supply Voltage	Vcc max	11	V
Power Dissipation	Pd max	720	mW
Operating Temperature	Topg	-30~+80	°C
Storage Temperature	Tstg	-40~+150	°C

OPERATING CONDITION(Ta=25°C)

Characteristics	Symbol	Rating	Unit
Supply Voltage	Vcc	8.5	V
Operating Supply Voltage Range	Vcc op	7.0~10	V

BLOCK DIAGRAM

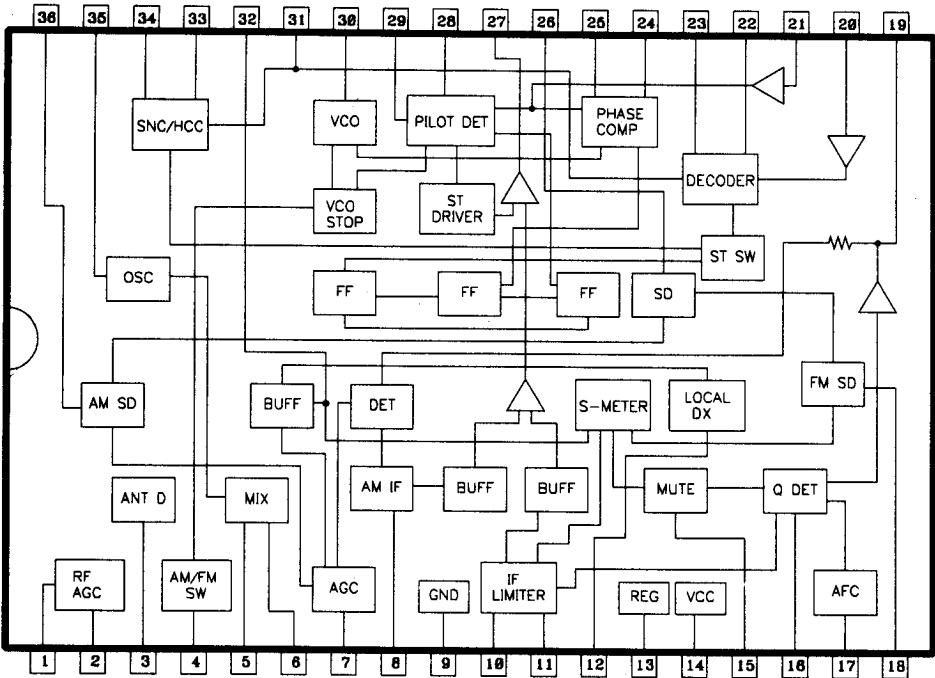

DBL 1091-V

(2) AM Mode : $f_c=1\text{MHz}$, $f_m=1\text{KHz}$, 30% Mod, $T_a=25^\circ\text{C}$, $V_{CC}=8.5\text{V0}$

Characteristic	Symbol	Test Condition	Min.	Typ.	Max.	Unit
Supply Current	ICCO	No Input	29	38	47	mA
Detection Output	V _o (1)	V _{in} = 25dB μ	18	40	68	mV
	V _o (2)	V _{in} = 74dB μ	60	80	120	mV
Signal to Noise Ratio	S/N(1)	V _{in} = 25dB μ	17	21	-	dB
	S/N(2)	V _{in} = 74dB μ	42	49	-	dB
Total Harmonic Distortion	THD(1)	V _{in} = 74dB μ	-	0.35	1.0	%
	THD(2)	V _{in} = 130dB μ	-	0.4	2.0	%
LED ON Sens.	LED-ON	V ₂₆ = 2.0V	21	30	39	dB μ
IF Buffer Output	V _{IF}	V _{in} = 50dB μ , V ₁₂ = 5.0V	100	180	260	mV
Signal Meter Output	VSM(1)	No Input	0	0.7	1.0	V
	VSM(2)	V _{in} = 74dB μ	2.6	3.7	5.2	V
RF AGC on Input	AGC-ON	V ₁ = 3.0V	50	57	64	dB μ
Pin diode drive current	I _{ANTD}	V ₁ = 0.7V	2.5	3.0	4.0	mA
AM OSC Level	V _{osc}	No Input	160	180	200	mV

DBL 1091-V

□ ELECTRICAL CHARACTERISTICS

(1) FM Mode : $f_c = 10.7\text{MHz}$, $f_m = 1\text{kHz}$, 75kHz Dev. , $T_a = 25^\circ\text{C}$, $V_{cc} = 8.5\text{V}$

Characteristic	Symbol	Test Condition	Min.	Typ.	Max.	Unit
Supply Current	ICCO	No Input	35	45	55	mA
Detection Output	V_o	$V_{in} = 100\text{dB}\mu$	165	250	345	mV
Signal to Noise Ratio	S/N	$V_{in} = 100\text{dB}\mu$	66	75	-	dB
-3dB Limiting Sens.	-3dBLS	$V_{od} = 3\text{dB down}$	27	37	47	$\text{dB}\mu$
AM Rejection Ratio	AMR	$V_{in} = 100\text{dB}\mu$, AM = 1kHz, 30% mod	48	60	-	dB
Signal Meter Output	VSM(1)	No Input	0	0.15	0.7	V
	VSM(2)	$V_{in} = 100\text{dB}\mu$	5.0	6.1	7.0	V
LED ON Sens.	LED-ON	$V_{26} = 2.0\text{V}$	43	58	73	$\text{dB}\mu$
LED ON BW	LED-BW	$V_{in} = 100\text{dB}\mu$, $V_{26} \geq 2.0\text{V}$	95	145	190	KHz
IF Buffer Output	V_{IF}	$V_{in} = 100\text{dB}\mu$, $V_{12} = 5.0\text{V}$	160	210	360	mV
Channel Separation	SEP.	$V_{in} = 100\text{dB}\mu$, L+R=90%, PILOT=10%	30	45	-	dB
ST LED ON Sens.	LED-ON	$V_{in} = 100\text{dB}\mu$ PILOT mod. degree at ST-LED ON	1.8	3.2	5.0	%
ST LED OFF Sens.	LED-OFF	$V_{in} = 100\text{dB}\mu$ PILOT mod. degree at ST-LED OFF	-	2.2	-	%
Total Harmonic Distortion	THD(1)	$V_{in} = 100\text{dB}\mu$, MONO	-	0.5	2.5	%
	THD(2)	$V_{in} = 100\text{dB}\mu$, MAIN	-	0.5	2.5	%
Channel Balance	CB	$V_{in} = 100\text{dB}\mu$, MONO	-1.5	0	+1.5	dB
SNC Output Voltage	V_{o_sus}	$V_{in} = 100\text{dB}\mu$, L-R=90% PILOT = 10%, $V_{34} = 0.1\text{V}$	-	0.5	5.0	mV
HCC Output ATT	Att HCC	$V_{in} = 100\text{dB}\mu$, L+R=90% PILOT=10%, $V_{33} = 0.6\text{V}$, $f_m = 10\text{kHz}$	-10	-5.0	-0.5	dB

TYPICAL PERFORMANCE CHARACTERISTICS

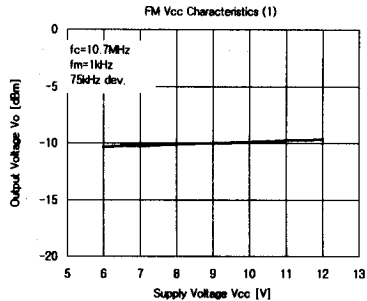
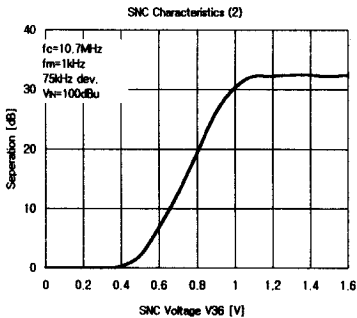
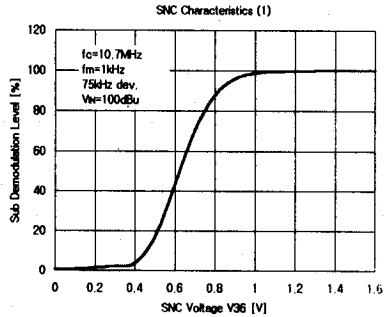
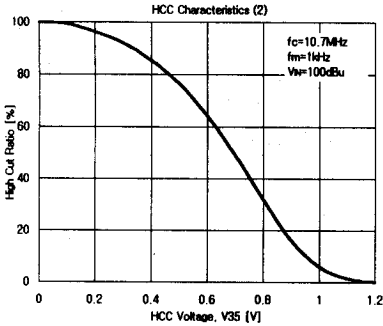
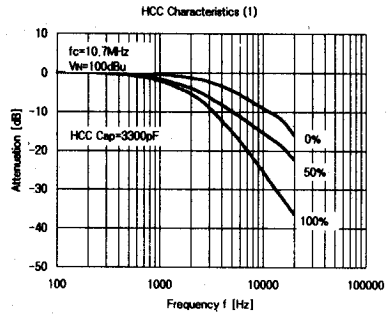
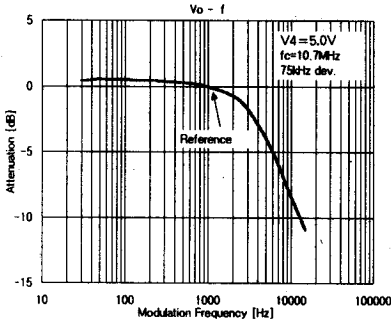
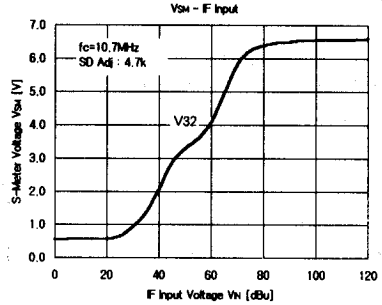
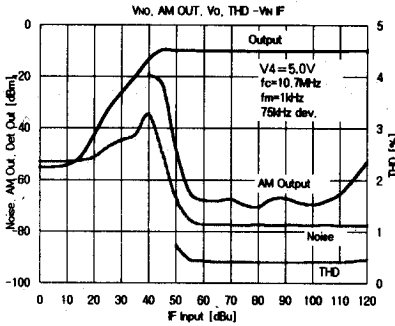

□ TYPICAL PERFORMANCE CHARACTERISTICS(continued)

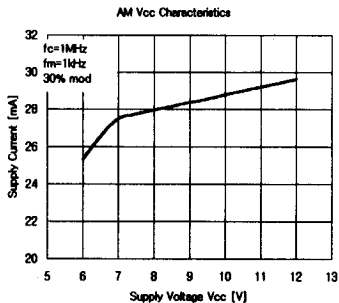
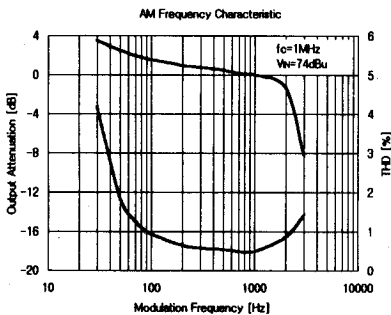
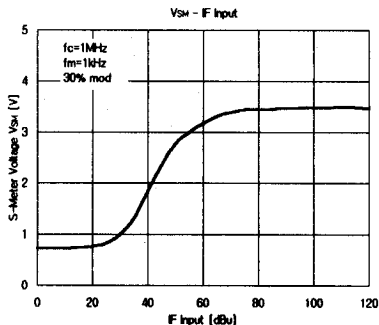
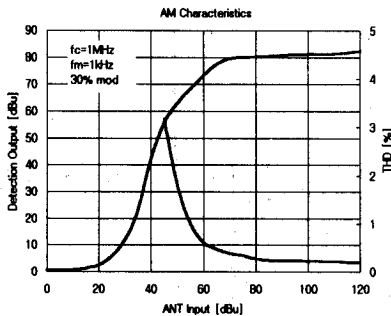
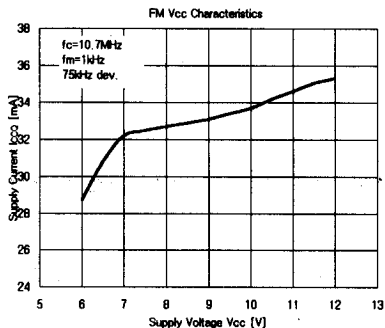
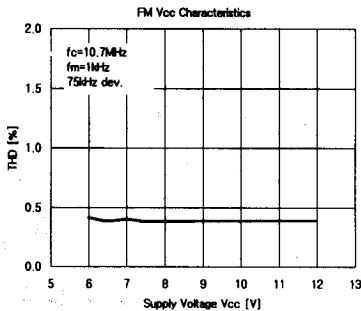
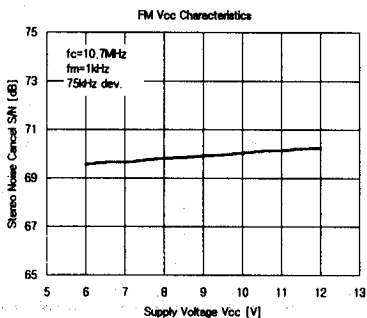

DBL 1091-V

□ TEST CIRCUIT

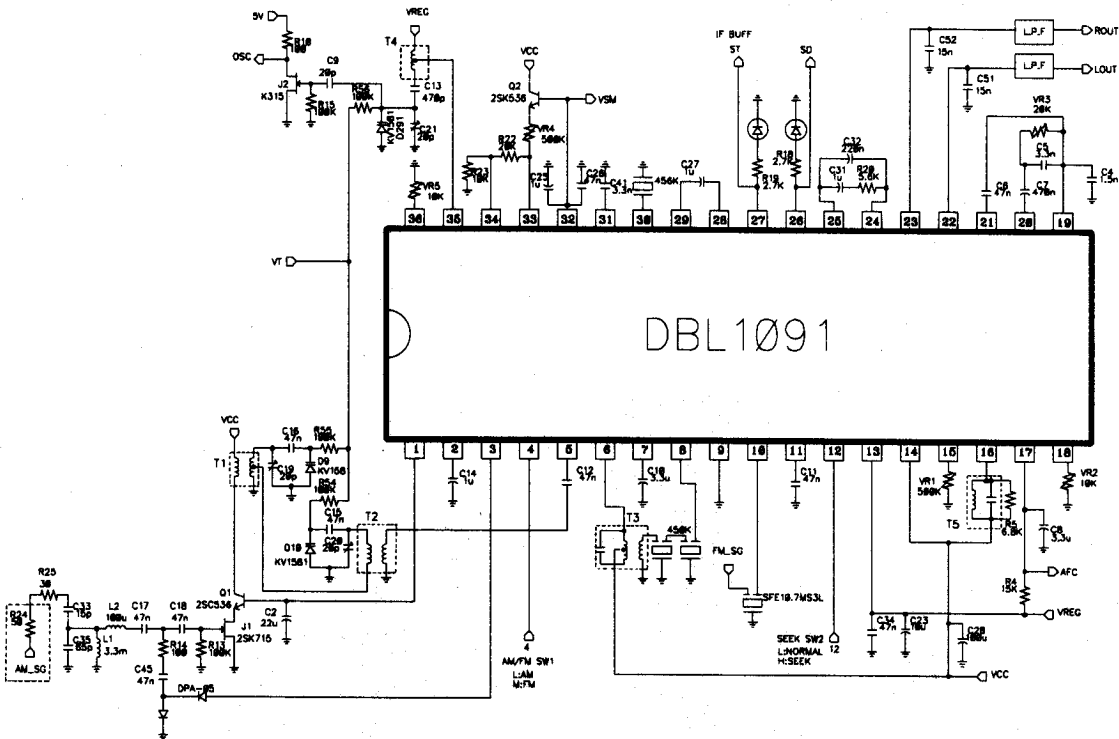

DBL 1091-V

□ APPLICATION CIRCUIT

