

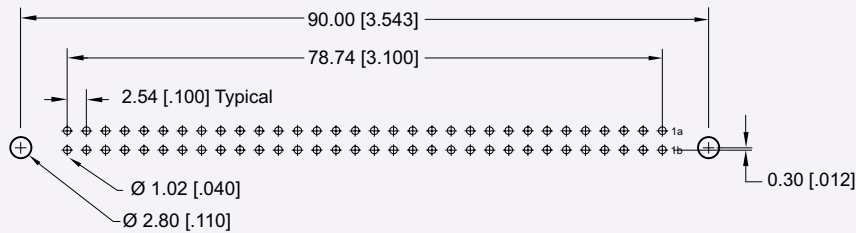

DIN 41612

Type Q, Q/2, Q/3 Male Connectors

Type Q, 64 Positions

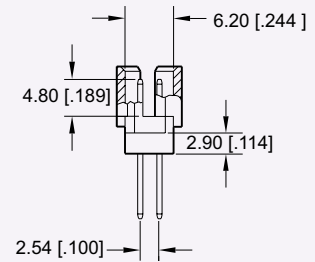
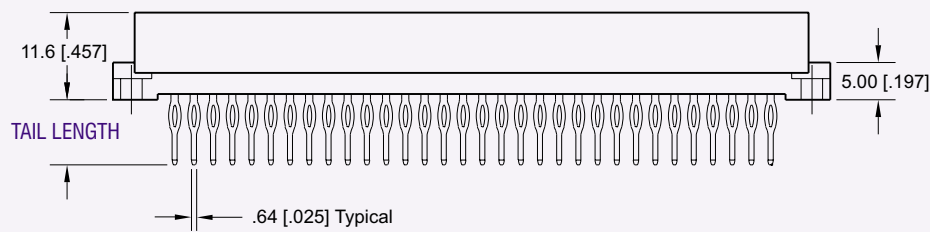
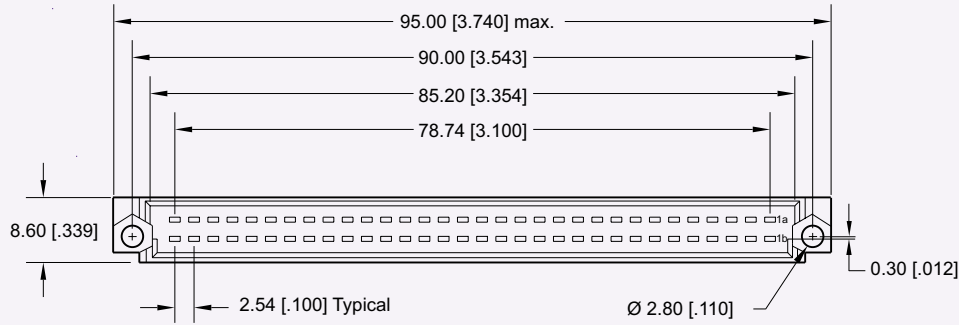

Recommended P. C. Board Layout

Dimensions are in mm [inches]

TAIL LENGTH OPTIONS

Press Fit

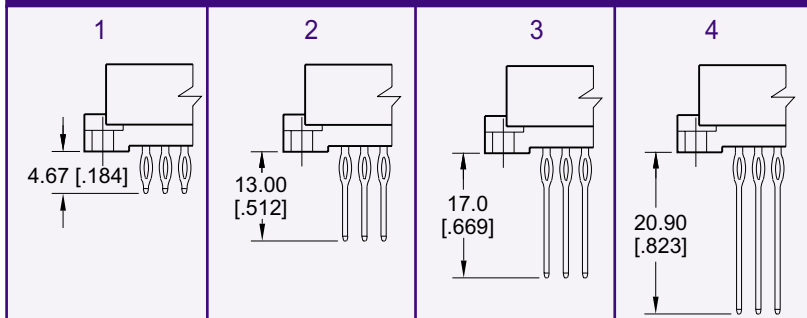

Solder and Wire Wrap

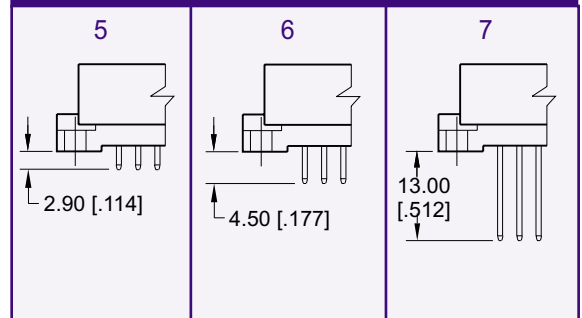

Type Q/2, 32 Positions

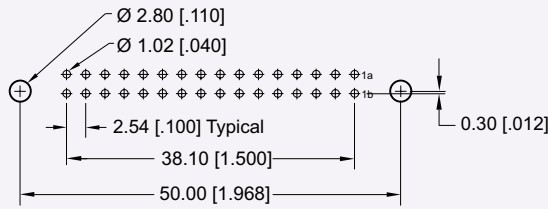
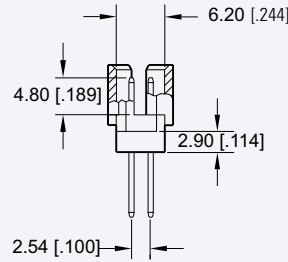
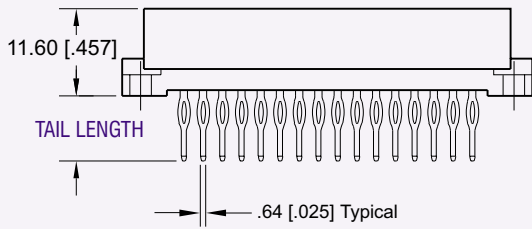
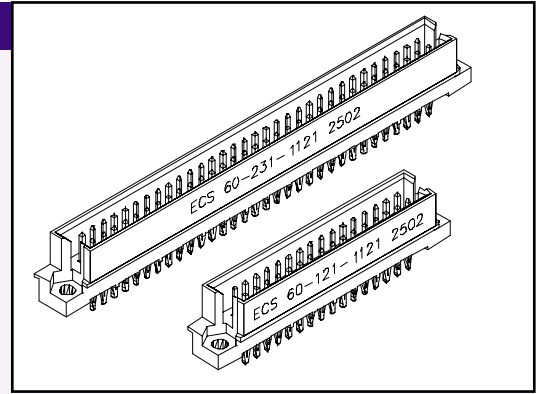
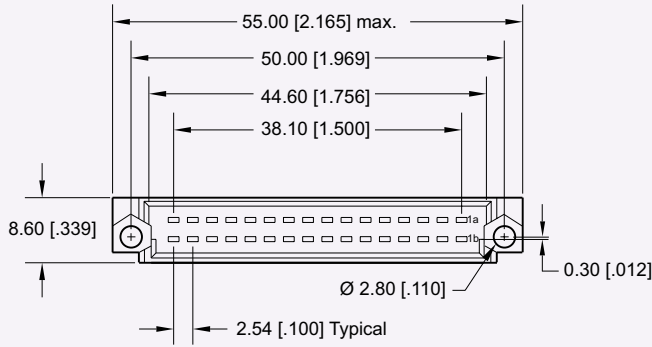

Recommended P. C. Board Layout

Dimensions are in mm [inches]

PART NUMBERING

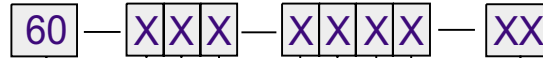

MC = Mounting Clip
Blank = No Mounting Clip

SERIES CODE

DIN 41612 Type Q, Q/2, Q/3 Male

BODY STYLE

- 0 = Q/3 (20 positions) not shown
- 1 = Q/2 (32 positions)
- 2 = Q (64 positions)

NUMBER OF CONTACTS

- 0 = 20
- 1 = 16
- 2 = 32
- 3 = 64

CONTACT LOADING

- 1 = Row A and B fully populated
 - 2 = Row A fully populated, Row B not populated
 - 3 = Row B fully populated, Row A not populated
- Consult Factory for other Loading Options

TAIL PLATING

- 1 = Tin Lead
- 2 = Gold flash (.200" from pin tip)
- 3 = Gold plate 30µ" (.200" from pin tip)
- 4 = Gold plate 15µ" (.200" from pin tip)

MATING AREA PLATING

- 1 = Class 1
- 2 = Class 2
- 3 = Class 3

TAIL LENGTH

- 1 = 4.67 [.184] Press-Fit
- 2 = 13.00 [.512] Press-Fit
- 3 = 17.00 [.669] Press-Fit
- 4 = 20.90 [.823] Press-Fit
- 5 = 2.90 [.114] Dip Solder
- 6 = 4.50 [.177] Dip Solder
- 7 = 13.00 [.512] Dip Solder Wire Wrap

CONTACT TYPE

- 1 = For all Press Fit Connectors
(Consult Factory if EM/LB Contact Required)
- 1 = Solder Version Requiring EM/LB Contacts
(Consult Factory)
- 2 = Solder Versions Standard Contacts

Note: Press Fit Connectors required a press in tool.
See page C-48 for Press In Tool information.

CONSULT FACTORY FOR CONNECTORS BUILT TO YOUR DESIGN