

**12Vin  
Input**

**15Vout  
Output**

**7Amp  
Current**

**2250Vdc  
Isolation**

**Quarter-brick  
DC/DC Converter**

The IQ12150QTA07 InQor™ Tera quarter-brick converter is a next-generation, board-mountable, isolated, fixed switching frequency DC/DC converter that uses synchronous rectification to achieve extremely high conversion efficiency. The power dissipated by the converter is so low that a heatsink is not required, which saves cost, weight, height, and application effort. An optional base-plated version is available for those demanding applications that require heatsinks, and for harsh environments an encased version is also available. The Tera series offers the maximum usable output current for any standard "quarter-brick" module. RoHS compliant (see page 9).

## InQor™ Tera



Open Frame

Encased

### Operational Features

- Ultra-high efficiency, >90% at full rated load current
- Delivers up to 7 amps of output current (105W) with minimal derating - no heatsink required
- Wide operating input voltage range: 9V – 22V
- Fixed frequency switching provides predictable EMI performance
- No minimum load requirement means no preload resistors required

### Mechanical Features

- Industry standard quarter-brick pin-out configuration
- Industry standard size: 1.45" x 2.3" (36.8x58.4mm)
- Total open frame height less than 0.43" (10.9mm), permits better airflow and smaller card pitch
- Total open frame weight: 1.5 oz. (42 grams)
- Flanged pins designed to permit surface mount soldering (allowing to avoid wave solder) using FPiP technique

### Control Features

- On/Off control referenced to input side
- Remote sense for the output voltage compensates for output distribution drops
- Output voltage trim permits custom voltages and voltage margining

### Protection Features

- Input under-voltage lockout disables converter at low input voltage conditions
- Output current limit and short circuit protection protects converter and load from permanent damage and consequent hazardous conditions
- Active back bias limit prevents damage to converter from external load induced pre-bias
- Output over-voltage protection protects load from damaging voltages
- Thermal shutdown protects converter from abnormal environmental conditions

### Safety Features

- 2250V, 30 MΩ input-to-output isolation provides input/output ground separation
- UL/cUL 60950-1 recognized (US & Canada), basic insulation rating (pending)
- TUV certified to EN60950-1 (pending)
- Meets 72/23/EEC and 93/68/EEC directives which facilitates CE Marking in user's end product
- Board and plastic components meet UL94V-0 flammability requirements



# Technical Specification

**Input: 9-22 V**  
**Output: 15.0 V**  
**Current: 7 A**  
**Package: Quarter-brick**

## IQ12150QTA07 ELECTRICAL CHARACTERISTICS

T<sub>A</sub>=25°C, airflow rate=300 LFM, V<sub>in</sub>=12Vdc unless otherwise noted; full operating temperature range is -40°C to +100°C ambient temperature with appropriate power derating. Specifications subject to change without notice.

Parameter	Min.	Typ.	Max.	Units	Notes & Conditions
<b>ABSOLUTE MAXIMUM RATINGS</b>					
Input Voltage					
Non-Operating			30	V	Continuous
Operating			22	V	Continuous
Isolation Voltage					Basic insulation, Pollution Degree 2
Input to Output			2250	V <sub>dc</sub>	
Input to Base-Plate			2250	V <sub>dc</sub>	
Output to Base-Plate			2250	V <sub>dc</sub>	
Operating Temperature	-40		100	°C	
Storage Temperature	-55		125	°C	
Voltage at ON/OFF input pin	-2		18	V	
<b>INPUT CHARACTERISTICS</b>					
Operating Input Voltage Range	9	12	22	V	25V transient for 100ms; see note 1
Input Under-Voltage Lockout					
Turn-On Voltage Threshold	9.2	9.5	9.8	V	
Turn-Off Voltage Threshold	8.3	8.6	8.9	V	
Lockout Voltage Hysteresis		0.9		V	
Maximum Input Current			17.0	A	9 V <sub>in</sub> , trim up, in current limit
No-Load Input Current		330	410	mA	
Disabled Input Current		2.0	3.0	mA	
Response to Input Transient		0.5		V	250V/ms input transient
Input Terminal Ripple Current		280		mA	RMS
Recommended Input Fuse			30	A	Fast acting external fuse recommended
Input Filter Component Values (L\C)		0.47\24		μH\μF	Internal values; see Figure E
Recommended External Input Capacitance		470		μF	Typical ESR 0.1-0.2Ω
<b>OUTPUT CHARACTERISTICS</b>					
Output Voltage Set Point	14.850	15.000	15.150	V	
Output Voltage Regulation					
Over Line		±0.1	±0.3	%	
Over Load		±0.1	±0.3	%	
Over Temperature	-225		225	mV	
Total Output Voltage Range	14.625		15.375	V	Over sample, line, load, temperature & life
Output Voltage Ripple and Noise					20MHz bandwidth; see note 2
Peak-to-Peak		30	60	mV	Full Load
RMS		5.0	10.0	mV	Full Load
Operating Output Current Range	0		7	A	Subject to thermal derating
Output DC Current-Limit Inception	7.7	8.4	9.1	A	Output Voltage 10% Low
Output DC Current-Limit Shutdown Voltage		10.7		V	
Back-Drive Current Limit while Enabled		0.3		A	Negative current drawn from output
Back-Drive Current Limit while Disabled	0	15	50	mA	Negative current drawn from output
Maximum Output Capacitance			1,000	μF	V <sub>out</sub> nominal at full load (resistive load)
<b>DYNAMIC CHARACTERISTICS</b>					
Output Voltage during Load Current Transient					
For a Step Change in Output Current (0.1A/μs)		700		mV	50% to 75% to 50% I <sub>out</sub> max
Settling Time		50		μs	To within 1% V <sub>out</sub> nom
Turn-On Transient					
Turn-On Time		9		ms	Full load, V <sub>out</sub> =90% nom.
Start-Up Inhibit Time	200	230	250	ms	-40°C to +125°C; Figure E
Output Voltage Overshoot		0		%	1,000 μF load capacitance, I <sub>out</sub> = 0A
<b>EFFICIENCY</b>					
100% Load		90.4		%	See Figure 1 for efficiency curve
50% Load		90.5		%	See Figure 1 for efficiency curve
<b>ISOLATION CHARACTERISTICS</b>					
Isolation Voltage (dielectric strength)					
Input to Output			2250	V <sub>dc</sub>	
Input to Base-Plate			2250	V <sub>dc</sub>	
Output to Base-Plate			2250	V <sub>dc</sub>	
Isolation Resistance		30		MΩ	
Isolation Capacitance (input to output)		1,000		pF	See note 3

Note 1: Start-up guaranteed above 10V, but will operate down to 9V.

Note 2: Output is terminated with 1 μF ceramic and 15 μF low-ESR tantalum capacitors (only 1μF ceramic for V<sub>out</sub> > 18 V).

Note 3: Higher values of isolation capacitance can be added external to the module.



# Technical Specification

**Input:** 9-22 V  
**Output:** 15.0 V  
**Current:** 7 A  
**Package:** Quarter-brick

## ELECTRICAL CHARACTERISTICS (Continued)

Parameter	Min.	Typ.	Max.	Units	Notes & Conditions
<b>TEMPERATURE LIMITS FOR POWER DERATING CURVES</b>					
Semiconductor Junction Temperature			125	°C	Package rated to 150°C
Board Temperature			125	°C	UL rated max operating temp 130°C
Transformer Temperature			125	°C	See Figure 3 for derating curve
Maximum Baseplate Temperature, T <sub>B</sub>			100	°C	Applies to baseplated and encased units only
<b>FEATURE CHARACTERISTICS</b>					
Switching Frequency	230	250	270	kHz	Regulation and Isolation stages
ON/OFF Control					
Off-State Voltage	2.4		18	V	
On-State Voltage	-2		0.8	V	
ON/OFF Control					Figures <a href="#">A</a> & <a href="#">B</a>
Pull-Up Voltage		5		V	
Pull-Up Resistance		50		kΩ	
Output Voltage Trim Range	-20		+10	%	Measured across Pins 8 & 4; Figure <a href="#">C</a>
Output Voltage Remote Sense Range			+10	%	Measured across Pins 8 & 4
Output Over-Voltage Protection	117	122	127	%	Over full temp range; % of nominal V <sub>out</sub>
Over-Temperature Shutdown		125		°C	Average PCB Temperature
Over-Temperature Shutdown Restart Hysteresis		10		°C	
Load Current Scale Factor		333			See Output Load Current app. note on our web
<b>RELIABILITY CHARACTERISTICS</b>					
Calculated MTBF (Telcordia)		2.5		10 <sup>6</sup> Hrs.	TR-NWT-000332; 80% load, 300LFM, 40°C T <sub>a</sub>
Calculated MTBF (MIL-217)		1.8		10 <sup>6</sup> Hrs.	MIL-HDBK-217F; 80% load, 300LFM, 40°C T <sub>a</sub>
Field Demonstrated MTBF				10 <sup>6</sup> Hrs.	See our <a href="#">website</a> for details

## STANDARDS COMPLIANCE

Parameter	Notes
<b>STANDARDS COMPLIANCE</b>	
UL/cUL 60950-1	File # E194341, Basic insulation & pollution degree 2
EN60950-1	Certified by TUV
72/23/EEC	
93/68/EEC	
Needle Flame Test (IEC 695-2-2)	Test on entire assembly; board & plastic components UL94V-0 compliant
IEC 61000-4-2	ESD test, 8kV - NP, 15kV air - NP (Normal Performance)
GR-1089-CORE	Section 7 - electrical safety, Section 9 - bonding/grounding
Telcordia (Bellcore) GR-513	

- An external input fuse must always be used to meet these safety requirements. Contact SynQor for official safety certificates on new releases or download from the [SynQor website](#).

## OPTIONS

SynQor provides various options for Pin Length and Feature Set for this family of Power Interface Modules. Please consult the [last page](#) for information on available options.

## PATENTS

SynQor is protected under various patents. Please consult the [last page](#) for further information.

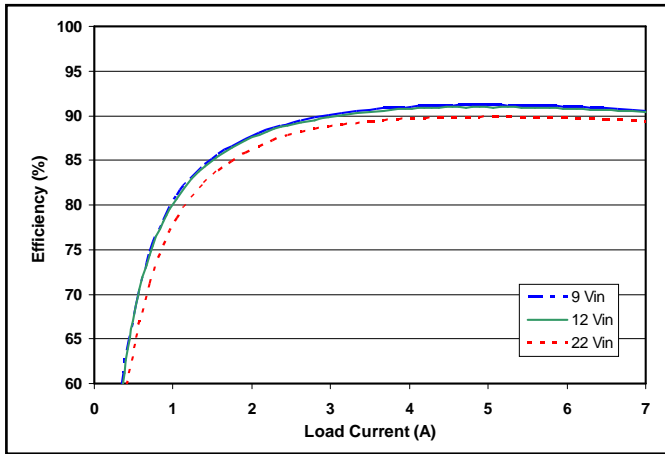

**Figure 1:** Efficiency at nominal output voltage vs. load current for minimum, nominal, and maximum input voltage at 25°C.

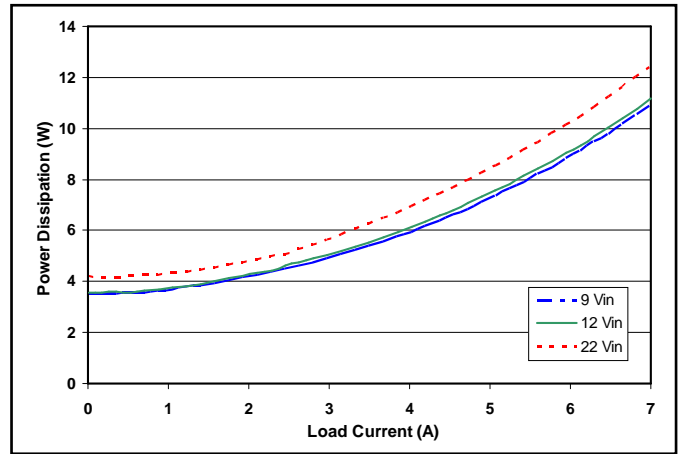

**Figure 2:** Power dissipation at nominal output voltage vs. load current for minimum, nominal, and maximum input voltage at 25°C.

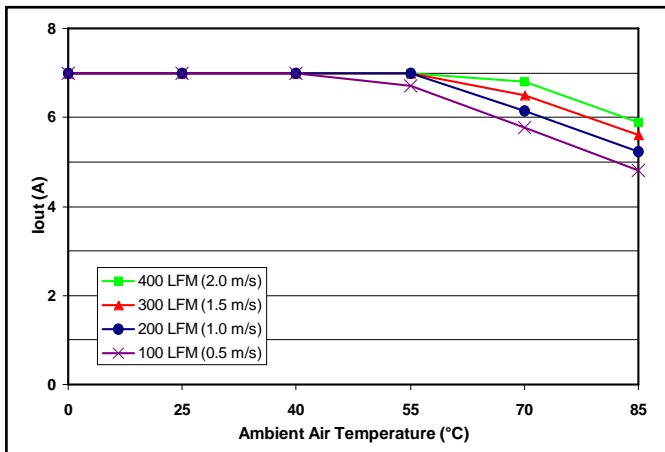

**Figure 3:** Open frame converter maximum output power derating vs. ambient air temperature for airflow rates of 100 LFM through 400 LFM. Air flows across the converter from pin 3 to pin 1 (nominal input voltage).

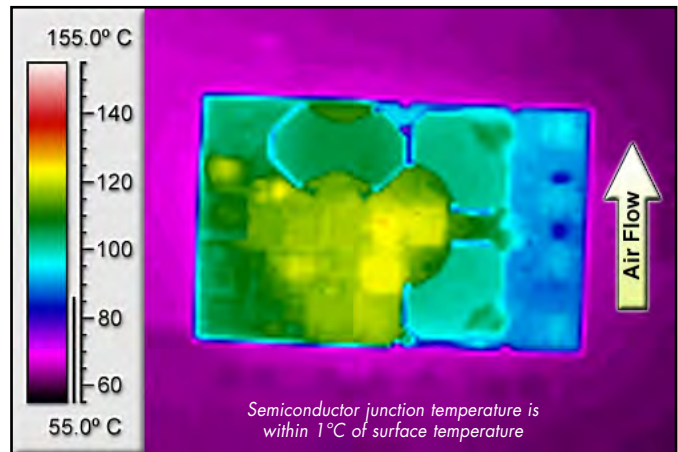

**Figure 4:** Open frame converter thermal plot at 7 amp load current (105 W) with 55°C air flowing at the rate of 200 LFM. Air flows across the converter from pin 3 to pin 1 (nominal input voltage).

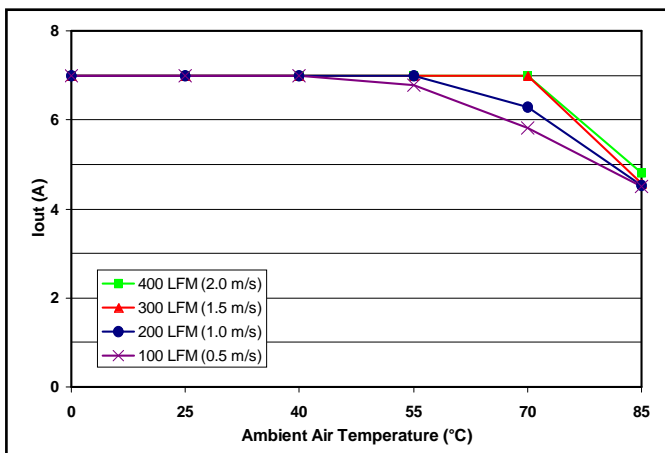

**Figure 5:** Base-plated converter (without heatsink) max. output power derating vs. ambient air temperature for airflow rates of 100 LFM through 400 LFM. Air flows across the converter from pin 3 to pin 1 (nominal input voltage, T<sub>B</sub>=100°C).

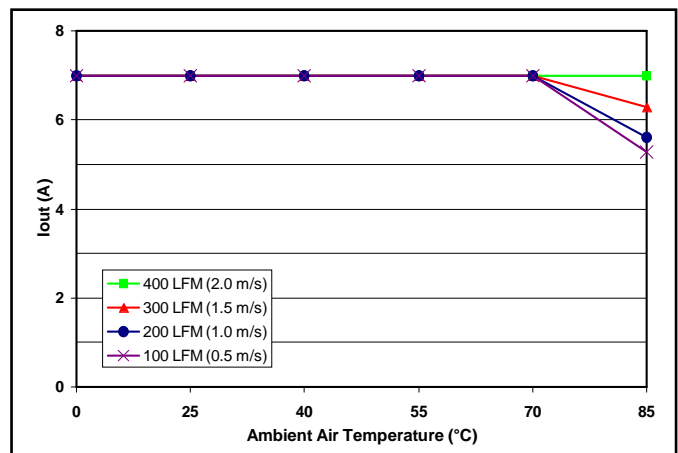

**Figure 6:** Base-plated converter (with 1/2" heatsink) max. output power derating vs. ambient air temperature for airflow rates of 100 LFM through 400 LFM. Air flows across the converter from pin 3 to pin 1 (nominal input voltage, T<sub>B</sub>=100°C).

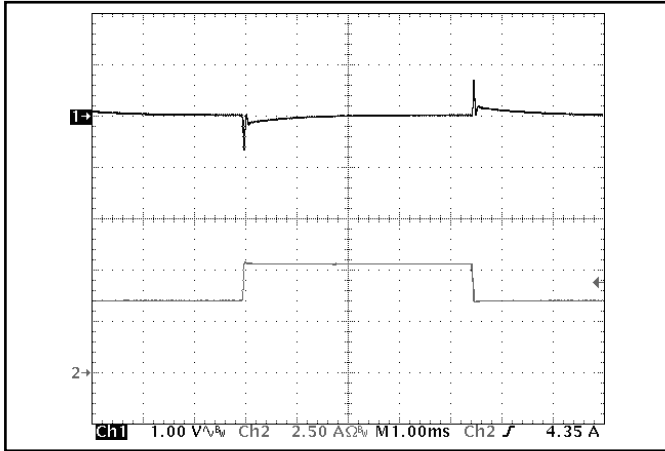

**Figure 7:** Output voltage response to step-change in load current (50%-75%-50% of  $I_{out(max)}$ ;  $di/dt = 0.1 A/\mu s$ ). Load cap:  $15 \mu F$ ,  $100 m\Omega$  ESR tantalum cap and  $1 \mu F$  ceramic cap. Ch 1:  $V_{out}$  (1 V/div), Ch 2:  $I_{out}$  (2.5 A/div).

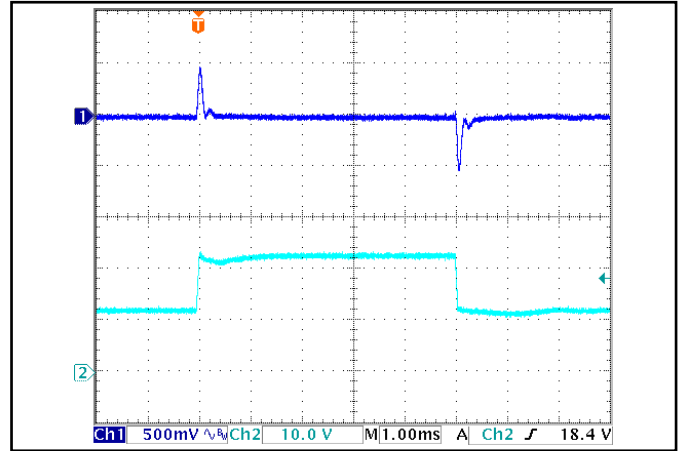

**Figure 8:** Output voltage response to step-change in input voltage (250 V/ms). Load cap:  $100 \mu F$ , electrolytic output capacitance. Ch 1:  $V_{out}$  (0.5 V/div), Ch 2:  $V_{in}$  (10 V/div).

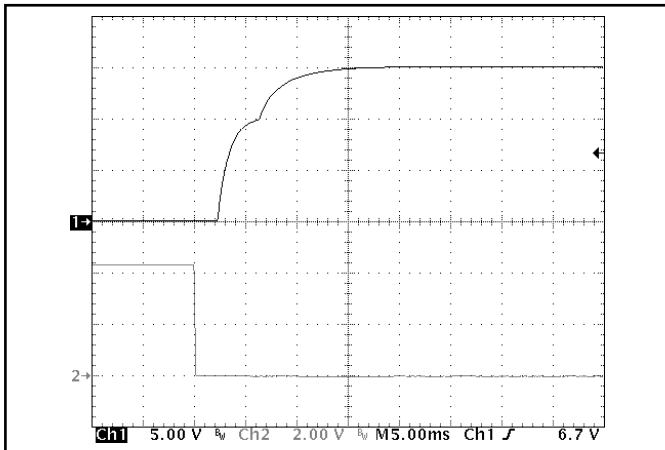

**Figure 9:** Turn-on transient at full load (resistive load) (2 ms/div). Input voltage pre-applied. Ch 1:  $V_{out}$  (5 V/div), Ch 2: ON/OFF input (2 V/div).

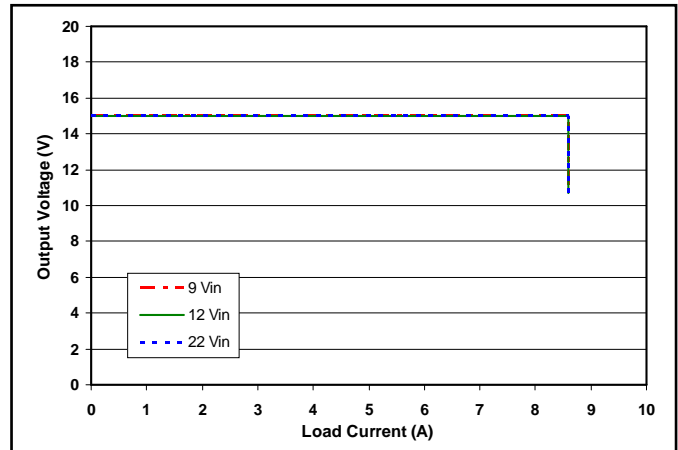

**Figure 10:** Output voltage vs. load current showing typical current limit curves and converter shutdown points.

### BASIC OPERATION AND FEATURES

The *InQor* series converter uses a two-stage power conversion topology. The first stage is a buck-converter that keeps the output voltage constant over variations in line, load, and temperature. The second stage uses a transformer to provide the functions of input/output isolation and voltage step-up or step-down to achieve the output voltage required.

Both the first stage and the second stage switch at a fixed frequency for predictable EMI performance. Rectification of the transformer's output is accomplished with synchronous rectifiers. These devices, which are MOSFETs with a very low on-state resistance, dissipate far less energy than Schottky diodes. This is the primary reason that the *InQor* converter has such high efficiency, even at very low output voltages and very high output currents.

Dissipation throughout the converter is so low that it does not require a heatsink for operation in many applications. Since a heatsink is not required, the *InQor* converter does not need a metal baseplate or potting material to help conduct the dissipated energy to the heatsink. The *InQor* converter can thus be built more simply and reliably using high yield surface mount techniques on a PCB substrate.

Nevertheless, for those thermally demanding applications that require heatsinks or cold-plate mounting, an optional base-plated version of the *InQor* is available. In addition, for applications having a harsh environment, a totally encased and base-plated version is also available.

The *InQor* series of half-brick and quarter-brick converters uses the industry standard footprint and pin-out configuration.

### CONTROL FEATURES

**REMOTE ON/OFF (Pin 2):** The ON/OFF input, Pin 2, permits the user to control when the converter is *on* or *off*. This input is referenced to the return terminal of the input bus,  $V_{in(-)}$ . The ON/OFF signal is active low (meaning that a low turns the converter *on*). Figure A details four possible circuits for driving the ON/OFF pin. Figure B is a detailed look of the internal ON/OFF circuitry.

**REMOTE SENSE(+)** (Pins 7 and 5): The SENSE(±) inputs correct for voltage drops along the conductors that connect the converter's output pins to the load.

Pin 7 should be connected to  $V_{out(+)}$  and Pin 5 should be connected to  $V_{out(-)}$  at the point on the board where regulation is desired. A remote connection at the load can adjust for a voltage drop only as large as that specified in this datasheet, that is

$$\frac{[V_{out(+)} - V_{out(-)}] - [V_{sense(+)} - V_{sense(-)}]}{Sense\ Range\ \% \times V_{out}}$$

Pins 7 and 5 must be connected for proper regulation of the output voltage. If these connections are not made, the converter will deliver an output voltage that is slightly higher than its specified value.

**Note:** the output over-voltage protection circuit senses the voltage across the output (pins 8 and 4) to determine when it should trigger, not the voltage across the converter's sense leads (pins 7 and 5). Therefore, the resistive drop on the board should be small enough so that output OVP does not trigger, even during load transients.

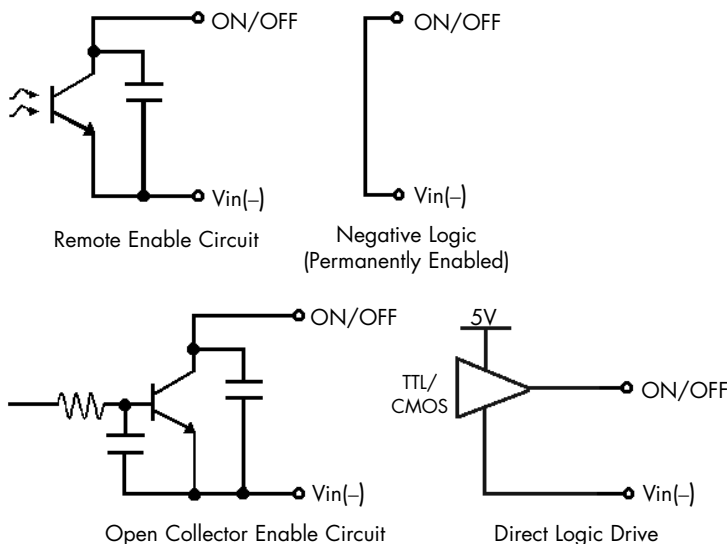

Figure A: Various circuits for driving the ON/OFF pin.

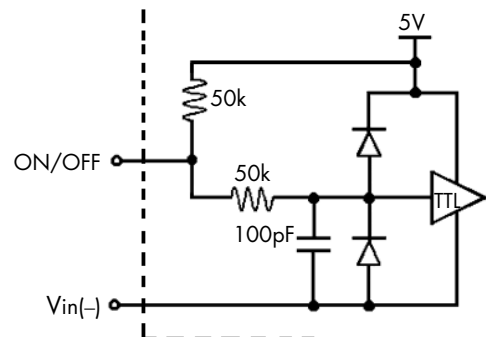

Figure B: Internal ON/OFF pin circuitry

**OUTPUT VOLTAGE TRIM (Pin 6):** The TRIM input permits the user to adjust the output voltage across the sense leads up or down according to the trim range specifications.

To decrease the output voltage, the user should connect a resistor between Pin 6 and Pin 5 (SENSE(-) input). For a desired decrease of the nominal output voltage, the value of the resistor should be

$$R_{\text{trim-down}} = \left( \frac{511}{\Delta\%} \right) - 10.22 \text{ (k}\Omega\text{)}$$

where

$$\Delta\% = \left| \frac{V_{\text{nominal}} - V_{\text{desired}}}{V_{\text{nominal}}} \right| \times 100\%$$

To increase the output voltage, the user should connect a resistor between Pin 6 and Pin 7 (SENSE(+) input). For a desired increase of the nominal output voltage, the value of the resistor should be

$$R_{\text{trim-up}} = \left( \frac{5.11V_{\text{OUT}}(100+\Delta\%)}{1.225\Delta\%} - \frac{511}{\Delta\%} - 10.22 \right) \text{ (k}\Omega\text{)}$$

where

$$V_{\text{OUT}} = \text{Nominal Output Voltage}$$

Figure C graphs the relationship between the trim resistor value and  $R_{\text{trim-up}}$  and  $R_{\text{trim-down}}$ , showing the total range the output voltage can be trimmed up or down.

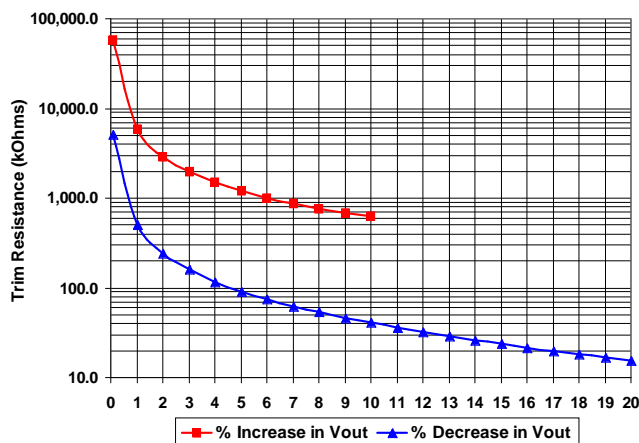

Figure C: Trim Graph

**Note:** the TRIM feature does not affect the voltage at which the output over-voltage protection circuit is triggered. Trimming the output voltage too high may cause the over-voltage protection circuit to engage, particularly during transients.

It is not necessary for the user to add capacitance at the Trim pin. The node is internally bypassed to eliminate noise.

**Total DC Variation of Vout:** For the converter to meet its full specifications, the maximum variation of the DC value of Vout, due to both trimming and remote load voltage drops, should not be greater than that specified for the output voltage trim range.

## PROTECTION FEATURES

**Input Under-Voltage Lockout:** The converter is designed to turn off when the input voltage is too low, helping avoid an input system instability problem, described in more detail in the application note titled "Input System Instability". The lockout circuitry is a comparator with DC hysteresis. When the input voltage is rising, it must exceed the typical Turn-On Voltage Threshold value (listed on the specifications page) before the converter will turn on. Once the converter is on, the input voltage must fall below the typical Turn-Off Voltage Threshold value before the converter will turn off.

**Output Current Limit:** The maximum current limit remains constant as the output voltage drops. However, once the impedance of the short across the output is small enough to make the output voltage drop below the specified Output DC Current-Limit Shutdown Voltage, the converter turns off.

The converter then enters a "hiccup mode" where it repeatedly turns on and off at a 5 Hz (nominal) frequency with a 5% duty cycle until the short circuit condition is removed. This prevents excessive heating of the converter or the load board.

**Output Over-Voltage Limit:** If the voltage across the output pins exceeds the Output Over-Voltage Protection threshold, the converter will immediately stop switching. This prevents damage to the load circuit due to 1) excessive series resistance in output current path from converter output pins to sense point, 2) a release of a short-circuit condition, or 3) a release of a current limit condition. Load capacitance determines exactly how high the output voltage will rise in response to these conditions. After 200 ms the converter will automatically restart.

**Over-Temperature Shutdown:** A temperature sensor on the converter senses the average temperature of the module. The thermal shutdown circuit is designed to turn the converter off when the temperature at the sensed location reaches the Over-Temperature Shutdown value. It will allow the converter to turn on again when the temperature of the sensed location falls by the amount of the Over-Temperature Shutdown Restart Hysteresis value.

### APPLICATION CONSIDERATIONS

**Input System Instability:** This condition can occur because any DC/DC converter appears incrementally as a negative resistance load. A detailed application note titled "Input System Instability" is available on the SynQor website which provides an understanding of why this instability arises, and shows the preferred solution for correcting it.

**Application Circuits:** Figure D provides a typical circuit diagram which details the input filtering and voltage trimming.

**Input Filtering and External Capacitance:** Figure E provides a diagram showing the internal input filter components. This filter dramatically reduces input terminal ripple current, which otherwise could exceed the rating of an external electrolytic input capacitor. The recommended external input capacitance is specified in the Input Characteristics section on the [Electrical Specifications page](#). More detailed information is available in the application note titled "EMI Characteristics" on the [SynQor website](#).

**Startup Inhibit Period:** The Startup Inhibit Period ensures that the converter will remain off for approximately 200ms when it is shut down for any reason. When an output short is present, this generates a 5Hz "hiccup mode," which prevents the converter from overheating. In all, there are seven ways that the converter can be shut down, initiating a Startup Inhibit Period:

- Input Under-Voltage Lockout
- Input Over-Voltage Shutdown (not present in Quarter-brick)
- Output Over-Voltage Protection
- Over Temperature Shutdown
- Current Limit
- Short Circuit Protection
- Turned off by the ON/OFF input

Figure F shows three turn-on scenarios, where a Startup Inhibit Period is initiated at  $t_0$ ,  $t_1$ , and  $t_2$ :

Before time  $t_0$ , when the input voltage is below the UVL threshold, the unit is disabled by the Input Under-Voltage Lockout feature. When the input voltage rises above the UVL threshold, the Input Under-Voltage Lockout is released, and a Startup Inhibit Period is initiated. At the end of this delay, the ON/OFF pin is evaluated, and since it is active, the unit turns on.

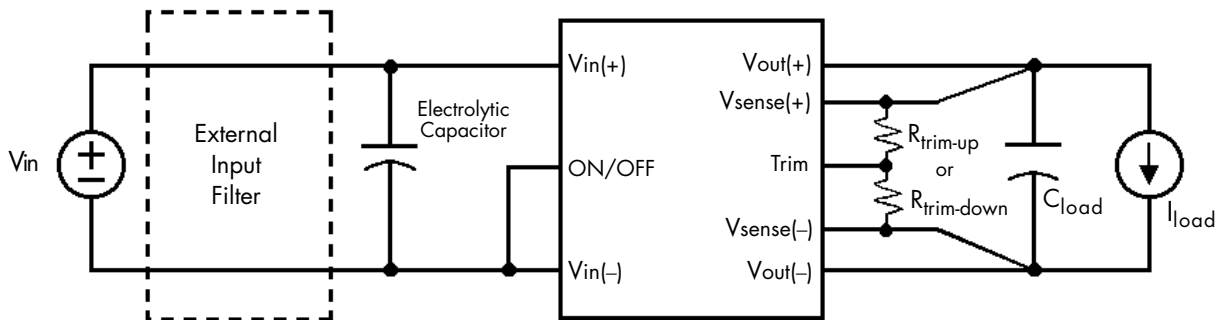

Figure D: Typical application circuit (negative logic unit, permanently enabled).

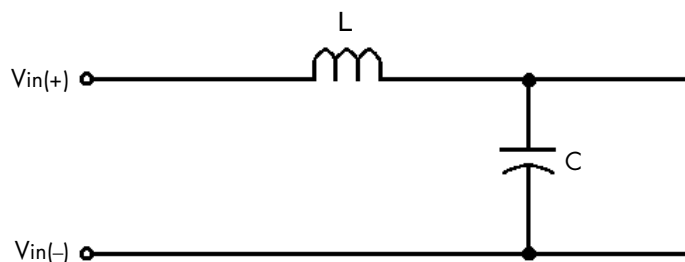

Figure E: Internal Input Filter Diagram (component values listed on the [specifications page](#)).



At time  $t_1$ , the unit is disabled by the ON/OFF pin, and it cannot be enabled again until the Startup Inhibit Period has elapsed.

When the ON/OFF pin goes high after  $t_2$ , the Startup Inhibit Period has elapsed, and the output turns on within the typical Turn-On Time.

An optional base-plated version is available for applications that require heatsinks, and an encased version is available for harsh environments.

**Thermal Considerations:** Because the *InQor* series of converters are so efficient, they don't need a heatsink in many applications. Figure 3 shows a power derating curve of an open frame converter for various ambient temperatures and airflow rates. These curves represent a condition which results in a maximum semiconductor junction temperature of 125°C, which is comfortable below the 150°C ratings of these components.

For those applications that are more demanding, or that require a cold-plate mounting, the *InQor* converters may be purchased with an optional base-plate. The maximum operating base-plate temperature,  $T_B$ , is 100°C. As long as the user's thermal system keeps  $T_B \leq 100^\circ\text{C}$ , the converter can deliver its full rated power.

A power derating curve can be calculated for any heatsink that is attached to the base-plate of the converter. It is only necessary to determine the thermal resistance,  $R_{THBA}$ , of the chosen heatsink between the base-plate and the ambient air for a given airflow

rate. This information is usually available from the heatsink vendor. The following formula can be used to determine the maximum power the converter can dissipate for a given thermal condition if its base-plate is to be no higher than 100°C.

$$P_{diss}^{max} = \frac{100^\circ\text{C} - T_A}{R_{THBA}}$$

This value of power dissipation can then be used in conjunction with the data shown in Figure 2 to determine the maximum load current (and power) that the converter can deliver in the given thermal condition.

For convenience, Figures 5 and 6 provide power derating curves for a converter with a base-plate without a heatsink and with a typical 1/2" high heatsink.

**RoHS Compliance:** The EU led RoHS (Restriction of Hazardous Substances) Directive bans the use of Lead, Cadmium, Hexavalent Chromium, Mercury, Polybrominated Biphenyls (PBB), and Polybrominated Diphenyl Ether (PBDE) in Electrical and Electronic Equipment. This SynQor product is 6/6 RoHS compliant. For more information please refer to SynQor's RoHS addendum available at our [RoHS Compliance / Lead Free Initiative](#) web page or e-mail us at [rohs@synqor.com](mailto:rohs@synqor.com).

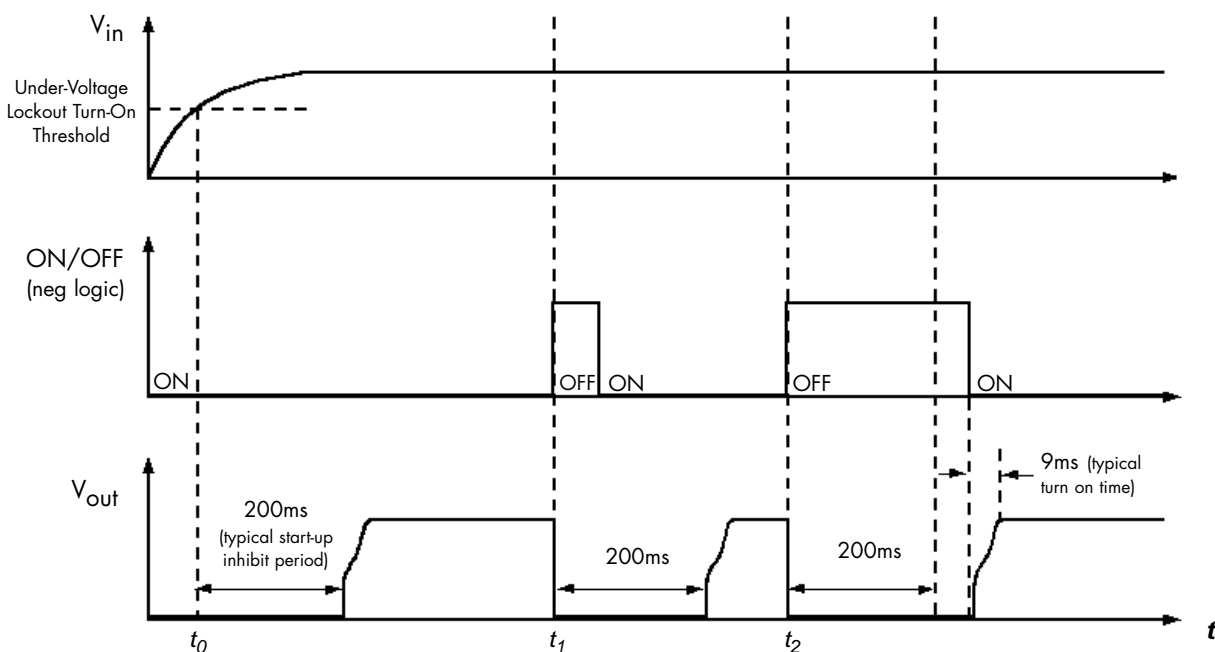
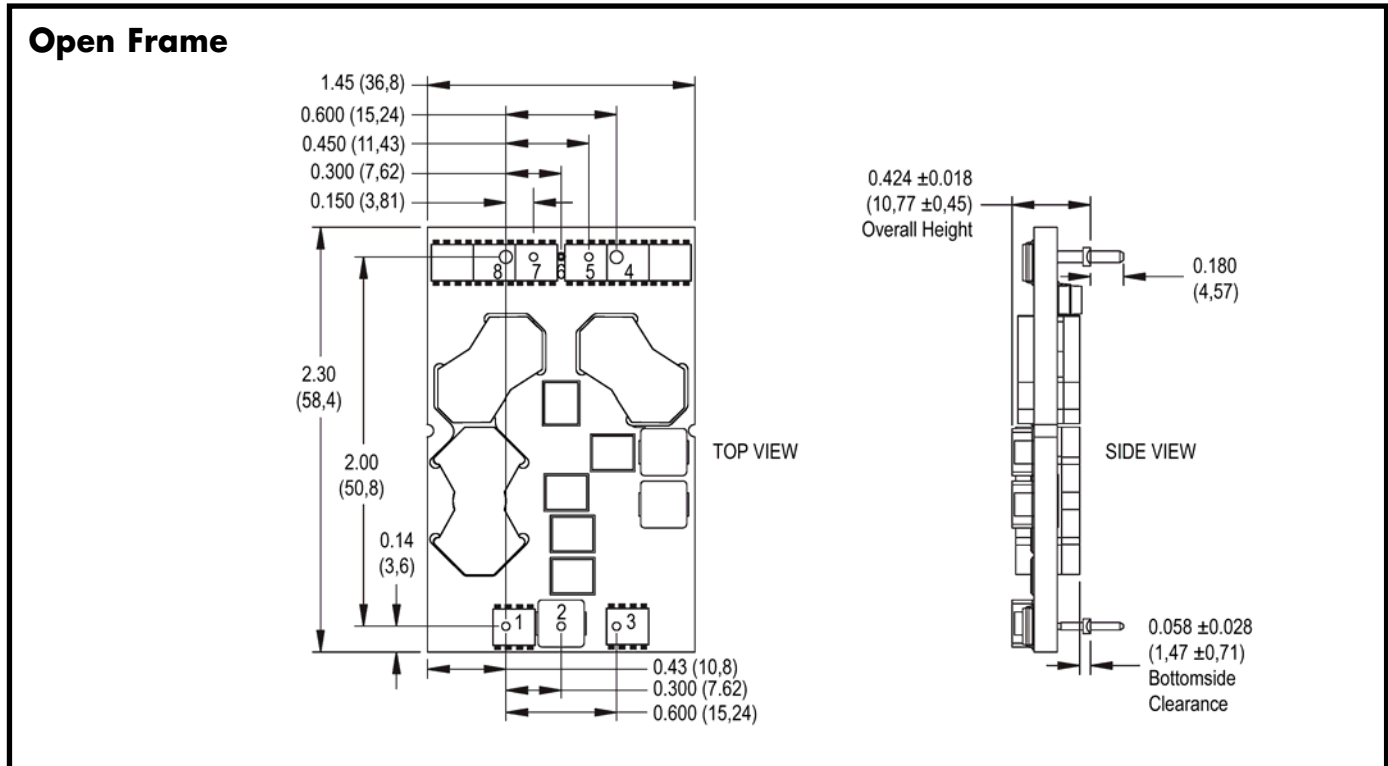

Figure F: Startup Inhibit Period (turn-on time not to scale)

**Input:** 9-22 V  
**Output:** 15.0 V  
**Current:** 7 A  
**Package:** Quarter-brick

### MECHANICAL DIAGRAM



### NOTES

- 1) Pins 1-3, 5-7 are 0.040" (1.02mm) diameter with 0.080" (2.03 mm) diameter standoff shoulders.
- 2) Pins 4 and 8 are 0.062" (1.57 mm) diameter with 0.100" (2.54 mm) diameter standoff shoulders.
- 3) Recommended pin length is 0.03" (0.76mm) greater than the PCB thickness.
- 4) All Pins: Material - Copper Alloy; Finish - Matte Tin over Nickel plate
- 5) Undimensioned components shown are for visual reference only.
- 6) Weight: Open frame: 1.5 oz. (42 g)  
Base-plated: 2.5 oz. (69 g) typical  
Encased: 3.02 oz. (85.7 g) typical
- 7) All dimensions in inches (mm)  
Tolerances: x.xx +/-0.02 in. (x.x +/-0.5mm)  
x.xxx +/-0.010 in. (x.xx +/-0.25mm)
- 8) Workmanship: Meets or exceeds IPC-A-610C Class II
- 9) UL/TUV standards require a clearance greater than 0.04" (1.02mm) between input and output for Basic insulation. This issue should be considered if any copper traces are on the top side of the user's board. Note that the ferrite cores are considered part of the input/primary circuit.
- 10) M3 screws used to bolt unit's baseplate to other surfaces (such as a heatsink) must not exceed 0.100" (2.54 mm) depth below the surface of the baseplate.
- 11) Applied torque per screw should not exceed 6in-lb. (0.7 Nm).
- 12) Baseplate flatness tolerance is 0.004" (.10mm) TIR for surface.

### PIN DESIGNATIONS

Pin No.	Name	Function
1	Vin(+)	Positive input voltage
2	ON/OFF	TTL input to turn converter on and off, referenced to Vin(-), with internal pull up.
3	Vin(-)	Negative input voltage
4	Vout(-)	Negative output voltage
5	SENSE(-)	Negative remote sense <sup>1</sup>
6	TRIM	Output voltage trim <sup>2</sup>
7	SENSE(+)	Positive remote sense <sup>3</sup>
8	Vout(+)	Positive output voltage

#### Notes:

1. SENSE(-) should be connected to Vout(-) either remotely or at the converter.
2. Leave TRIM pin open for nominal output voltage.
3. SENSE(+) should be connected to Vout(+) either remotely or at the converter.

### MECHANICAL DIAGRAM (continued)

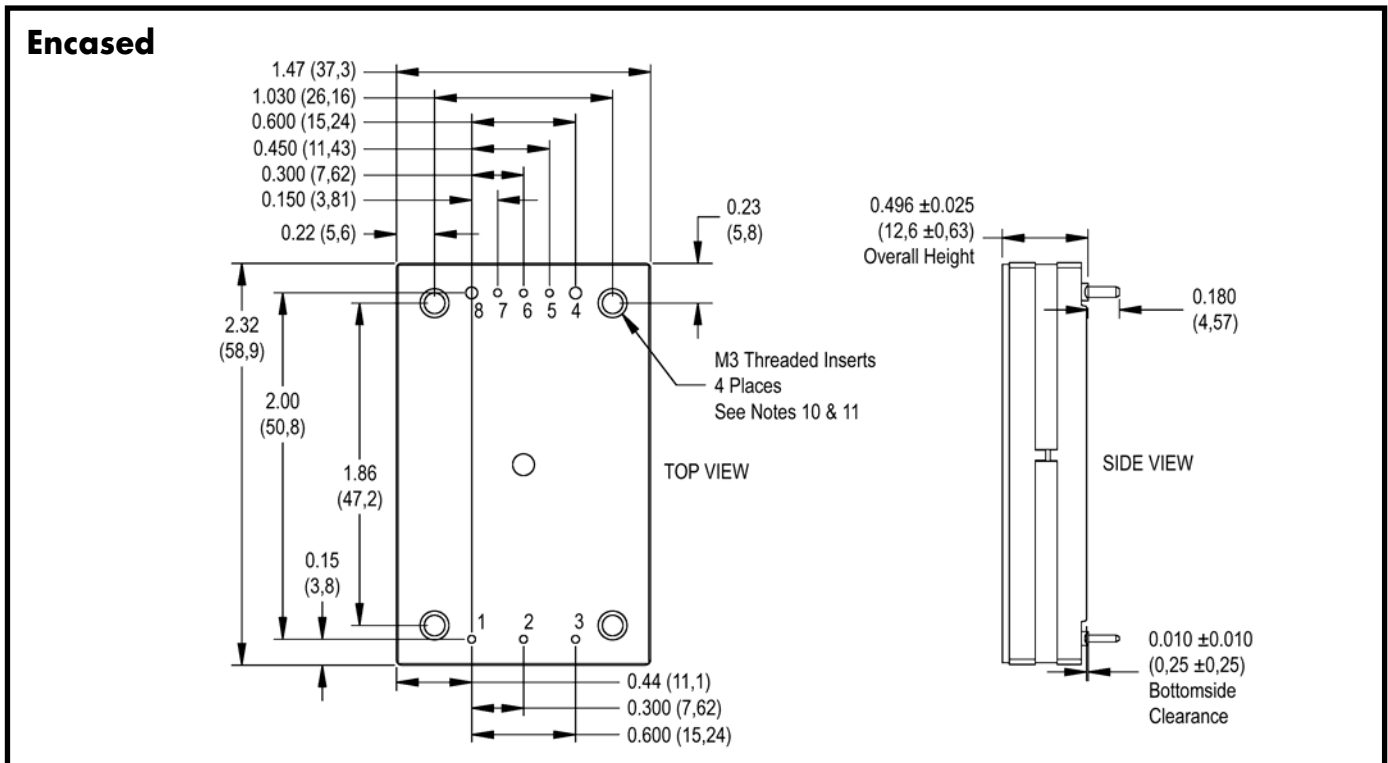
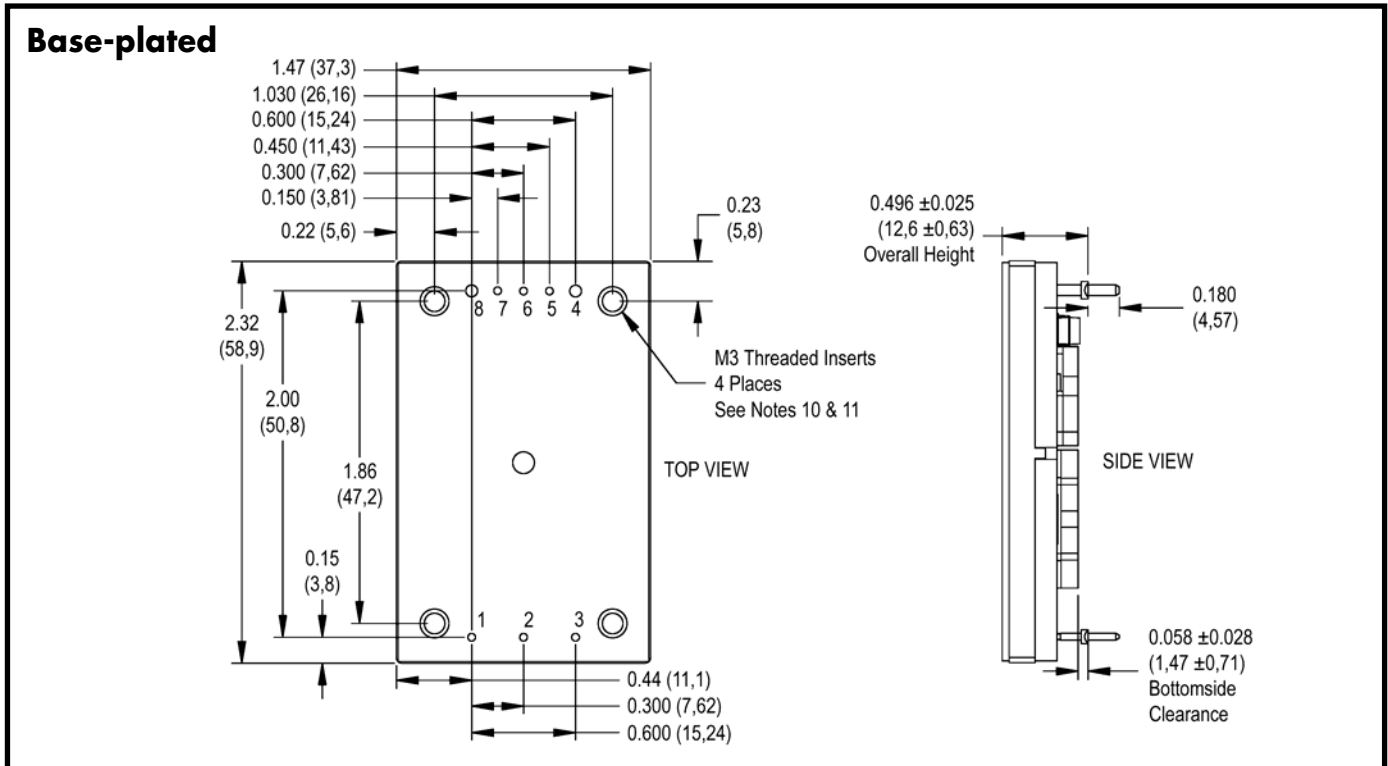



# Technical Specification

**Input:** 9-22 V  
**Output:** 15.0 V  
**Current:** 7 A  
**Package:** Quarter-brick

## PART NUMBERING SYSTEM

The part numbering system for SynQor's InQor DC/DC converters follows the format shown in the example below.

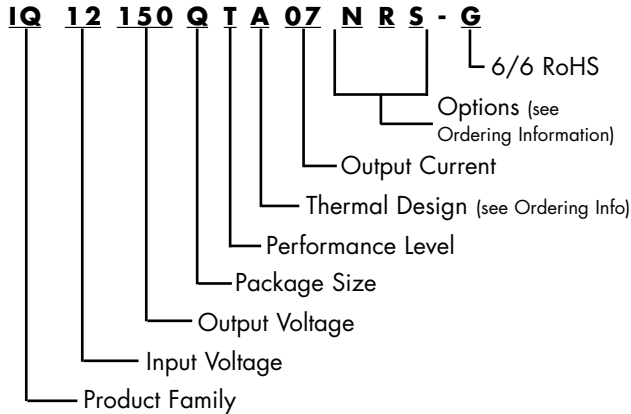

The first 12 characters comprise the base part number and the last 3 characters indicate available options. The "-G" suffix indicates 6/6 RoHS compliance.

## Application Notes

A variety of application notes and technical white papers can be downloaded in pdf format from our [website](#).

## PATENTS (additional patent applications may be filed)

SynQor holds the following patents, one or more of which might apply to this product:

5,999,417	6,222,742	6,545,890	6,577,109
6,594,159	6,731,520	6,894,468	6,896,526
6,927,987	7,050,309	7,072,190	7,085,146

## ORDERING INFORMATION

The tables below show the valid model numbers and ordering options for converters in this product family. When ordering SynQor converters, please ensure that you use the complete 15 character part number consisting of the 12 character base part number and the additional 3 characters for options. A "-G" suffix indicates the product is 6/6 RoHS compliant.

Model Number	Input Voltage	Output Voltage	Max Output Current
<b>IQ12018QT</b> w40xyz	9 - 22 V	1.8 V	40 A
<b>IQ12033QT</b> w30xyz	9 - 22 V	3.3 V	30 A
<b>IQ12050QT</b> w20xyz	9 - 22 V	5 V	20 A
<b>IQ12070QT</b> w14xyz	9 - 22 V	7 V	14 A
<b>IQ12120QT</b> w08xyz	9 - 22 V	12 V	8 A
<b>IQ12150QT</b> w07xyz	9 - 22 V	15 V	7 A
<b>IQ12240QT</b> w04xyz	9 - 22 V	24 V	4 A
<b>IQ12300QT</b> w03xyz	9 - 22 V	30 V	3 A
<b>IQ12480QT</b> w02xyz	9 - 22 V	48 V	2 A

The following option choices must be included in place of the x y z spaces in the model numbers listed above.

Options Description: w x y z			
Thermal Design	Enable Logic	Pin Length	Feature Set
A - Open Frame B - Baseplated C - Encased	N - Negative	R - 0.180"	S - Standard

## Contact SynQor for further information:

**Phone:** 978-849-0600  
**Toll Free:** 888-567-9596  
**Fax:** 978-849-0602  
**E-mail:** [power@synqor.com](mailto:power@synqor.com)  
**Web:** [www.synqor.com](http://www.synqor.com)  
**Address:** 155 Swanson Road  
 Boxborough, MA 01719  
 USA

### Warranty

SynQor offers a three (3) year limited warranty. Complete warranty information is listed on our [website](#) or is available upon request from SynQor.

Information furnished by SynQor is believed to be accurate and reliable. However, no responsibility is assumed by SynQor for its use, nor for any infringements of patents or other rights of third parties which may result from its use. No license is granted by implication or otherwise under any patent or patent rights of SynQor.